



THE DATASHEET OF ISO1541DR



ISO154x Low-Power Bidirectional I²C Isolators

1 Features

- Isolated bidirectional, I²C compatible, communication
- Supports up to 1-MHz operation
- 3-V to 5.5-V supply range
- Open-drain outputs With 3.5-mA Side 1 and 35-mA Side 2 sink current capability
- –40°C to +125°C operating temperature
- ±50-kV/μs transient immunity (Typical)
- HBM ESD protection of 4 kV on all pins; 8 kV on bus pins
- Safety-related certifications:
 - 4242-V_{PK} isolation per DIN EN IEC 60747-17 (VDE 0884-17)
 - 2500-V_{RMS} isolation for 1 minute per UL 1577
 - CSA approval per IEC 62368-1 end equipment standard
 - CQC basic insulation per GB4943.1-2011

2 Applications

- Isolated I²C buses
- SMBus and PMBus interfaces
- Open-drain networks
- Motor control systems
- Battery management
- I²C level shifting

3 Description

The ISO1540 and ISO1541 devices are low-power, bidirectional isolators that are compatible with I²C interfaces. These devices have logic input and output buffers that are separated by Texas Instruments Capacitive Isolation technology using a silicon dioxide (SiO₂) barrier. When used with isolated power supplies, these devices block high voltages, isolate grounds, and prevent noise currents from entering the local ground and interfering with or damaging sensitive circuitry.

This isolation technology provides for function, performance, size, and power consumption advantages when compared to optocouplers. The ISO1540 and ISO1541 devices enable a complete isolated I²C interface to be implemented within a small form factor.

The ISO1540 has two isolated bidirectional channels for clock and data lines while the ISO1541 has a bidirectional data and a unidirectional clock channel. The ISO1541 is useful in applications that have a single controller while the ISO1540 is suitable for multi-controller applications. For applications where clock stretching by the target is possible, the ISO1540 device should be used.

Isolated bidirectional communication is accomplished within these devices by offsetting the low-level output voltage on side 1 to a value greater than the high-level input voltage on side 1, thus preventing an internal logic latch that otherwise would occur with standard digital isolators.

Device Information

| PART NUMBER | PACKAGE | BODY SIZE (NOM) |
|-------------|----------|-------------------|
| ISO1540 | SOIC (8) | 4.90 mm × 3.91 mm |
| ISO1541 | | |

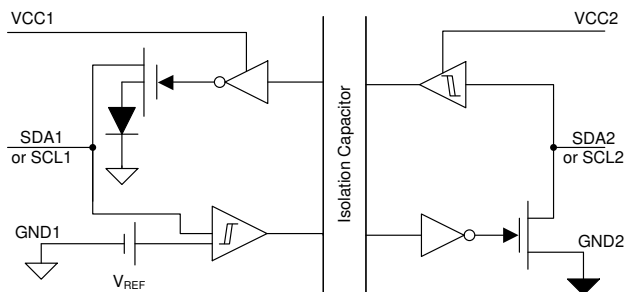

Simplified Schematic



Table of Contents

| | | | |
|--|----|--|----|
| 1 Features | 1 | 7.1 Overview..... | 19 |
| 2 Applications | 1 | 7.2 Functional Block Diagrams..... | 19 |
| 3 Description | 1 | 7.3 Feature Description..... | 20 |
| 4 Revision History | 2 | 7.4 Isolator Functional Principle..... | 20 |
| 5 Pin Configuration and Functions | 4 | 7.5 Device Functional Modes..... | 21 |
| 6 Specifications | 6 | 8 Application and Implementation | 22 |
| 6.1 Absolute Maximum Ratings..... | 6 | 8.1 Application Information..... | 22 |
| 6.2 ESD Ratings..... | 6 | 8.2 Typical Application..... | 23 |
| 6.3 Recommended Operating Conditions..... | 6 | 9 Power Supply Recommendations | 25 |
| 6.4 Thermal Information..... | 7 | 10 Layout | 27 |
| 6.5 Power Ratings..... | 7 | 10.1 Layout Guidelines..... | 27 |
| 6.6 Insulation Specifications..... | 8 | 10.2 Layout Example..... | 27 |
| 6.7 Safety-Related Certifications..... | 9 | 11 Device and Documentation Support | 28 |
| 6.8 Safety Limiting Values..... | 9 | 11.1 Documentation Support..... | 28 |
| 6.9 Electrical Characteristics..... | 10 | 11.2 Related Links..... | 28 |
| 6.10 Supply Current Characteristics..... | 11 | 11.3 Receiving Notification of Documentation Updates.. | 28 |
| 6.11 Timing Requirements..... | 11 | 11.4 Community Resources..... | 28 |
| 6.12 Switching Characteristics..... | 12 | 11.5 Trademarks..... | 28 |
| 6.13 Insulation Characteristics Curves..... | 13 | 12 Mechanical, Packaging, and Orderable Information | 28 |
| 6.14 Typical Characteristics..... | 14 | | |
| 7 Detailed Description | 19 | | |

4 Revision History

NOTE: Page numbers for previous revisions may differ from page numbers in the current version.

Changes from Revision E (March 2019) to Revision F (December 2022) Page

| | |
|---|---|
| • Changed all instances of legacy terminology to controller and target where I ² C is mentioned..... | 1 |
| • Editorial and cosmetic changes throughout the document..... | 1 |
| • Updated electrical and switching parameters..... | 6 |
| • Updated 'DIN VDE V 0884-11:2017-01' to 'DIN EN IEC 60747-17 (VDE 0884-17)' and removed references to 'CSA/IEC 60950-1'..... | 9 |

Changes from Revision D (December 2016) to Revision E (March 2019) Page

| | |
|--|----|
| • Changed VDE Standard name From: DIN V VDE V 0884-10 (VDE V 0884-10): 2006-12 To: DIN VDE V 0884-11:2017-01 in Section 1 | 1 |
| • Changed Section 1 bullet From: CSA Component Acceptance Notice 5A, IEC 60950-1 and IEC 61010-1 End Equipment Standards To: CSA approval per IEC 60950-1 and IEC 62368-1 end equipment standards..... | 1 |
| • Updated certifications approval status, numbers, standard names, and details according to the latest agency certificates in Section 6.7 table..... | 9 |
| • Changed both bypass capacitors From: 10 µF To: 0.1 µF in . Even though larger capacitors can be used, 0.1 µF is the minimum recommended bypass capacitor size..... | 24 |
| • Changed both bypass capacitors From: 10 µF To: 0.1 µF in . Even though larger capacitors can be used, 0.1 µF is the minimum recommended bypass capacitor size..... | 24 |

Changes from Revision C (June 2015) to Revision D (December 2016) Page

| | |
|---|----|
| • Deleted the <i>Device Comparison Table</i> ; see the <i>Features List</i> table for device comparison | 4 |
| • Changed the status of CQC certification from planned to certified | 9 |
| • Changed the <i>Regulatory Information</i> table to <i>Safety-Related Certifications</i> and updated content..... | 9 |
| • Changed formatting of supply current parameters to combine device and sides. Moved parameters to separate table | 11 |
| • Added the <i>Receiving Notification of Documentation Updates</i> section | 28 |

Changes from Revision B (May 2013) to Revision C (June 2015) Page

- Added *Pin Configuration and Functions* section, *ESD Ratings* table, *Feature Description* section, *Device Functional Modes*, *Application and Implementation* section, *Power Supply Recommendations* section, *Layout* section, *Device and Documentation Support* section, and *Mechanical, Packaging, and Orderable Information* section 1
- VDE Standard changed to DIN V VDE V 0884-10 (VDE V 0884-10): 2006-12 1
- Changed minimum air gap (Clearance) parameter, L(I01), to external clearance, CLR, and minimum external tracking (creepage) parameter, L(I02), to external creepage..... 8
- Changed values and test conditions in the *Insulation Specifications* table.....8
- Changed the descriptions of VDE and CSA information 9

Changes from Revision A (October 2012) to Revision B (May 2013) Page

- Change Safety Feature From: (VDE 0884 Part 2) (Pending) To: (VDE 0884 Part 2) (Approved)..... 1
- Changed, VDE column From: File number: 40016131 (pending) To: File number: 40016131.....9

Changes from Revision * (July 2012) to Revision A (October 2012) Page

- Changed From: CSA Component Acceptance Notice 5A (Pending) To: CSA Component Acceptance Notice 5A (Approved)..... 1
 - Changed From: IEC 60950-1 and IEC 61010-1 End Equipment Standards (Pending) To: IEC 60950-1 and IEC 61010-1 End Equipment Standards (Approved)..... 1
 - Changed [Section 6.7](#), CSA column From: File number: 220991 (pending) To: File number: 220991.....9
-

5 Pin Configuration and Functions

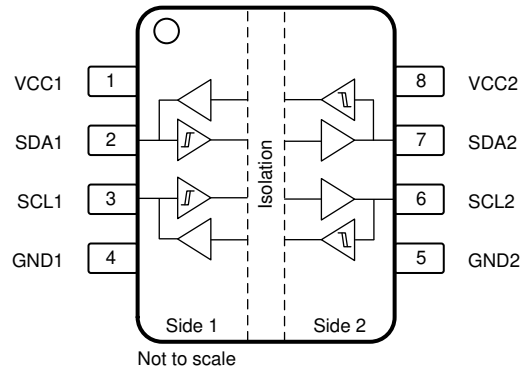

Figure 5-1. ISO1540 D Package 8-Pin SOIC Top View

Table 5-1. Pin Functions—ISO1540

| PIN | | I/O | DESCRIPTION |
|------|-----|-----|-------------------------------------|
| NAME | NO. | | |
| GND1 | 4 | — | Ground, side 1 |
| GND2 | 5 | — | Ground, side 2 |
| SCL1 | 3 | I/O | Serial clock input / output, side 1 |
| SCL2 | 6 | I/O | Serial clock input / output, side 2 |
| SDA1 | 2 | I/O | Serial data input / output, side 1 |
| SDA2 | 7 | I/O | Serial data input / output, side 2 |
| VCC1 | 1 | — | Supply voltage, side 1 |
| VCC2 | 8 | — | Supply voltage, side 2 |

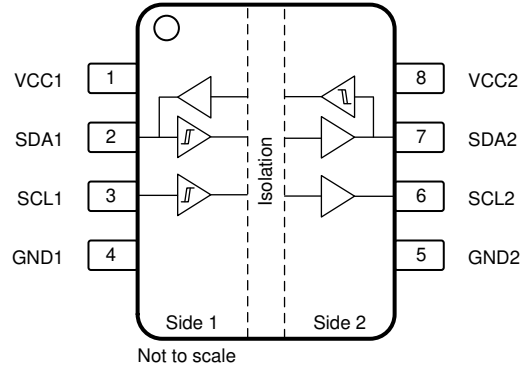

Figure 5-2. ISO1541 D Package 8-Pin SOIC Top View

Table 5-2. Pin Functions—ISO1541

| PIN | | I/O | DESCRIPTION |
|------|-----|-----|------------------------------------|
| NAME | NO. | | |
| GND1 | 4 | — | Ground, side 1 |
| GND2 | 5 | — | Ground, side 2 |
| SCL1 | 3 | I | Serial clock input, side 1 |
| SCL2 | 6 | O | Serial clock output, side 2 |
| SDA1 | 2 | I/O | Serial data input / output, side 1 |
| SDA2 | 7 | I/O | Serial data input / output, side 2 |
| VCC1 | 1 | — | Supply voltage, side 1 |
| VCC2 | 8 | — | Supply voltage, side 2 |

6 Specifications

6.1 Absolute Maximum Ratings

over operating free-air temperature range (unless otherwise noted)^{(1) (2)}

| | | MIN | MAX | UNIT |
|--|------------|------|---------------------------|------|
| Voltage | VCC1, VCC2 | -0.5 | 6 | V |
| | SDA1, SCL1 | -0.5 | VCC1 + 0.5 ⁽³⁾ | |
| | SDA2, SCL2 | -0.5 | VCC2 + 0.5 ⁽³⁾ | |
| I _O Output current | SDA1, SCL1 | 0 | 20 | mA |
| | SDA2, SCL2 | 0 | 100 | |
| T _{J(MAX)} Maximum junction temperature | | | 150 | °C |
| T _{stg} Storage temperature | | -65 | 150 | °C |

- (1) Stresses beyond those listed under *Absolute Maximum Ratings* may cause permanent damage to the device. These are stress ratings only, which do not imply functional operation of the device at these or any other conditions beyond those indicated under *Recommended Operating Conditions*. Exposure to absolute-maximum-rated conditions for extended periods may affect device reliability.
- (2) All voltage values here within are with respect to the local ground pin (GND1 or GND2) and are peak voltage values.
- (3) Maximum voltage must not exceed 6 V.

6.2 ESD Ratings

| | | VALUE | UNIT |
|--|--|----------|-------|
| V _(ESD) Electrostatic discharge | Human body model (HBM), per ANSI/ESDA/JEDEC JS-001 ⁽¹⁾ | Bus pins | ±8000 |
| | | All pins | ±4000 |
| | Charged-device model (CDM), per JEDEC specification JESD22-C101 ⁽²⁾ | | ±1500 |

- (1) JEDEC document JEP155 states that 500-V HBM allows safe manufacturing with a standard ESD control process.
- (2) JEDEC document JEP157 states that 250-V CDM allows safe manufacturing with a standard ESD control process.

6.3 Recommended Operating Conditions

| | | MIN | MAX | UNIT |
|---------------------------------------|--|------------|------------|------|
| VCC1, VCC2 | Supply voltage | 3 | 5.5 | V |
| V _{SDA1} , V _{SCL1} | Input and output signal voltages, side 1 | 0 | VCC1 | V |
| V _{SDA2} , V _{SCL2} | Input and output signal voltages, side 2 | 0 | VCC2 | V |
| V _{IL1} | Low-level input voltage, side 1 | 0 | 0.5 | V |
| V _{IH1} | High-level input voltage, side 1 | 0.7 × VCC1 | VCC1 | V |
| V _{IL2} | Low-level input voltage, side 2 | 0 | 0.3 × VCC2 | V |
| V _{IH2} | High-level input voltage, side 2 | 0.7 × VCC2 | VCC2 | V |
| I _{OL1} | Output current, side 1 | 0.5 | 3.5 | mA |
| I _{OL2} | Output current, side 2 | 0.5 | 35 | mA |
| C1 | Capacitive load, side 1 | | 40 | pF |
| C2 | Capacitive load, side 2 | | 400 | pF |
| f _{MAX} | Operating frequency ⁽¹⁾ | | 1 | MHz |
| T _A | Ambient temperature | -40 | 125 | °C |
| T _J | Junction temperature | -40 | 136 | °C |
| T _{SD} | Thermal shutdown | 139 | 197 | °C |

- (1) This represents the maximum frequency with the maximum bus load (C) and the maximum current sink (I_O). If the system has less bus capacitance, then higher frequencies can be achieved.

6.4 Thermal Information

| THERMAL METRIC ⁽¹⁾ | | ISO154x | UNIT |
|-------------------------------|--|----------|------|
| | | D (SOIC) | |
| | | 8 PINS | |
| R _{θJA} | Junction-to-ambient thermal resistance | 114.6 | °C/W |
| R _{θJC(top)} | Junction-to-case (top) thermal resistance | 69.6 | °C/W |
| R _{θJB} | Junction-to-board thermal resistance | 55.3 | °C/W |
| Ψ _{JT} | Junction-to-top characterization parameter | 27.2 | °C/W |
| Ψ _{JB} | Junction-to-board characterization parameter | 54.7 | °C/W |
| R _{θJC(bot)} | Junction-to-case (bottom) thermal resistance | N/A | °C/W |

(1) For more information about traditional and new thermal metrics, see the [Semiconductor and IC Package Thermal Metrics](#) application report (SPRA953).

6.5 Power Ratings

| PARAMETER | | TEST CONDITIONS | MIN | TYP | MAX | UNIT |
|-----------------|--|--|-----|-----|-----|------|
| P _D | Maximum power dissipation (both sides) | VCC1 = VCC2 = 5.5 V, T _J = 150 °C, C1 = 20 pF, C2 = 400 pF; R1 = 1.4 kΩ, R2 = 94 Ω; Input a 1-MHz 50% duty cycle clock signal | | | 105 | mW |
| P _{D1} | Maximum power dissipation (side-1) | | | | 37 | mW |
| P _{D2} | Maximum power dissipation (side-2) | | | | 68 | mW |

6.6 Insulation Specifications

| PARAMETER | | TEST CONDITIONS | VALUE | UNIT |
|--|--|--|------------|-----------|
| GENERAL | | | | |
| CLR | External clearance ⁽¹⁾ | Shortest terminal-to-terminal distance through air | >4 | mm |
| CPG | External creepage ⁽¹⁾ | Shortest terminal-to-terminal distance across the package surface | >4 | mm |
| DTI | Distance through the insulation | Minimum internal gap (internal clearance) | 0.014 | mm |
| CTI | Comparative tracking index | DIN EN 60112 (VDE 0303-11); IEC 60112 | >400 | V |
| | Material group | | II | |
| | Overvoltage category | Rated mains voltage $\leq 150 V_{RMS}$ | I–IV | |
| | | Rated mains voltage $\leq 300 V_{RMS}$ | I–III | |
| DIN EN IEC 60747-17 (VDE 0884-17)⁽²⁾ | | | | |
| V_{IORM} | Maximum repetitive peak isolation voltage | AC voltage (bipolar) | 566 | V_{PK} |
| V_{IOTM} | Maximum transient isolation voltage | $V_{TEST} = V_{IOTM}$ $t = 60$ s (qualification) $t = 1$ s (100% production) | 4242 | V_{PK} |
| q_{pd} | Apparent charge ⁽³⁾ | Method a: After I/O safety test subgroup 2/3, $V_{ini} = V_{IOTM}$, $t_{ini} = 60$ s; $V_{pd(m)} = 1.2 \times V_{IORM} = 680 V_{PK}$, $t_m = 10$ s | <5 | pC |
| | | Method a: After environmental tests subgroup 1, $V_{ini} = V_{IOTM}$, $t_{ini} = 60$ s; $V_{pd(m)} = 1.6 \times V_{IORM} = 906 V_{PK}$, $t_m = 10$ s | <5 | |
| | | Method b1: At routine test (100% production) and preconditioning (type test) $V_{ini} = V_{IOTM}$, $t_{ini} = 1$ s; $V_{pd(m)} = 1.875 \times V_{IORM} = 1062 V_{PK}$, $t_m = 1$ s | <5 | |
| C_{IO} | Barrier capacitance, input to output ⁽⁴⁾ | $V_{IO} = 0.4 \sin(2\pi ft)$, $f = 1$ MHz | ~1 | pF |
| R_{IO} | Isolation resistance, input to output ⁽⁴⁾ | $V_{IO} = 500$ V, $T_A = 25^\circ\text{C}$ | $>10^{12}$ | Ω |
| | | $V_{IO} = 500$ V, $100^\circ\text{C} \leq T_A \leq 125^\circ\text{C}$ | $>10^{11}$ | |
| | | $V_{IO} = 500$ V at $T_S = 150^\circ\text{C}$ | $>10^9$ | |
| | Pollution degree | | 2 | |
| | Climatic category | | 40/125/21 | |
| UL 1577 | | | | |
| V_{ISO} | Withstand isolation voltage | $V_{TEST} = V_{ISO} = 2500 V_{RMS}$, $t = 60$ s (qualification); $V_{TEST} = 1.2 \times V_{ISO} = 3000 V_{RMS}$, $t = 1$ s (100% production) | 2500 | V_{RMS} |

- (1) Creepage and clearance requirements should be applied according to the specific equipment isolation standards of an application. Care should be taken to maintain the creepage and clearance distance of a board design to ensure that the mounting pads of the isolator on the printed-circuit board do not reduce this distance. Creepage and clearance on a printed-circuit board become equal in certain cases. Techniques such as inserting grooves and/or ribs on a printed circuit board are used to help increase these specifications.
- (2) This coupler is suitable for *basic electrical insulation* only within the maximum operating ratings. Compliance with the safety ratings shall be ensured by means of suitable protective circuits.
- (3) Apparent charge is electrical discharge caused by a partial discharge (pd).
- (4) All pins on each side of the barrier tied together creating a two-terminal device

6.7 Safety-Related Certifications

| VDE | CSA | UL | CQC |
|---|---|--|---|
| Certified according to DIN EN IEC 60747-17 (VDE 0884-17) and DIN EN 61010-1 (VDE 0411-1) | Certified according to CSA/IEC 62368-1 | Recognized under UL 1577 Component Recognition Program | Certified according to GB4943.1-2011 |
| Basic Insulation Maximum Transient Overvoltage, 4242 V _{PK} ; Maximum Repetitive Peak Voltage, 566 V _{PK} | 2.5-kV _{RMS} Insulation Rating; 300 V _{RMS} Basic Insulation working voltage per CSA 62368-1-14 and IEC 62368-1:2014 | Single protection, 2500 V _{RMS} | Basic Insulation, Altitude ≤ 5000 m, Tropical Climate, 250 V _{RMS} maximum working voltage |
| Certificate number: 40047657 | Master contract number: 220991 | File number: E181974 | Certificate number: CQC14001109540 |

6.8 Safety Limiting Values

Safety limiting intends to minimize potential damage to the isolation barrier upon failure of input or output circuitry. A failure of the I/O can allow low resistance to ground or the supply and, without current limiting, dissipate sufficient power to overheat the die and damage the isolation barrier, potentially leading to secondary system failures.

| PARAMETER | | TEST CONDITIONS | MIN | TYP | MAX | UNIT |
|----------------|---|---|-----|-----|-----|------|
| I _s | Safety input, output, or supply current | R _{θJA} = 114.6°C/W, V _I = 5.5 V, T _J = 150°C, T _A = 25°C, see Figure 6-1 | | | 198 | mA |
| | | R _{θJA} = 114.6°C/W, V _I = 3.6 V, T _J = 150°C, T _A = 25°C, see Figure 6-1 | | | 303 | |
| T _s | Safety temperature | | | | 150 | °C |

The safety-limiting constraint is the maximum junction temperature specified in the data sheet. The power dissipation and junction-to-air thermal impedance of the device installed in the application hardware determines the junction temperature. The assumed junction-to-air thermal resistance in the [Section 6.4](#) table is that of a device installed on a high-K test board for leaded surface-mount packages. The power is the recommended maximum input voltage times the current. The junction temperature is then the ambient temperature plus the power times the junction-to-air thermal resistance.

6.9 Electrical Characteristics

over recommended operating conditions, unless otherwise noted

| PARAMETER | | TEST CONDITIONS | MIN | TYP | MAX | UNIT |
|----------------------|---|--|-----------------------|----------------------|-----|-------------------|
| SIDE 1 (ONLY) | | | | | | |
| V_{ILT1} | Voltage input threshold low, SDA1 and SCL1 | | 480 | 550 | 660 | mV |
| V_{IHT1} | Voltage input threshold high, SDA1 and SCL1 | | 520 | 610 | 700 | mV |
| V_{HYST1} | Voltage input hysteresis | $V_{IHT1} - V_{ILT1}$ | 40 | 60 | | mV |
| V_{OL1} | Low-level output voltage, SDA1 and SCL1 ⁽¹⁾ | $0.5 \text{ mA} \leq (I_{SDA1} \text{ and } I_{SCL1}) \leq 3.5 \text{ mA}$ | 570 | | 800 | mV |
| ΔV_{OIT1} | Low-level output voltage to high-level input voltage threshold difference, SDA1 and SCL1 ^{(1) (2)} | $0.5 \text{ mA} \leq (I_{SDA1} \text{ and } I_{SCL1}) \leq 3.5 \text{ mA}$ | 50 | | | mV |
| SIDE 2 (ONLY) | | | | | | |
| V_{ILT2} | Voltage input threshold low, SDA2 and SCL2 | | $0.3 \times V_{CC2}$ | $0.4 \times V_{CC2}$ | | V |
| V_{IHT2} | Voltage input threshold high, SDA2 and SCL2 | | $0.4 \times V_{CC2}$ | $0.5 \times V_{CC2}$ | | V |
| V_{HYST2} | Voltage input hysteresis | $V_{IHT2} - V_{ILT2}$ | $0.05 \times V_{CC2}$ | | | V |
| V_{OL2} | Low-level output voltage, SDA2 and SCL2 | $0.5 \text{ mA} \leq (I_{SDA2} \text{ and } I_{SCL2}) \leq 35 \text{ mA}$ | | | 0.4 | V |
| BOTH SIDES | | | | | | |
| $ I_i $ | Input leakage currents, SDA1, SCL1, SDA2, and SCL2 | $V_{SDA1}, V_{SCL1} = V_{CC1};$ $V_{SDA2}, V_{SCL2} = V_{CC2}$ | | 0.01 | 10 | μA |
| C_i | Input capacitance to local ground, SDA1, SCL1, SDA2, and SCL2 | $V_i = 0.4 \times \sin(2E6\pi t) + 2.5 \text{ V}$ | | 7 | | pF |
| CMTI | Common-mode transient immunity | See Figure 7-3 | 25 | 50 | | kV/ μs |
| V_{CCUV} | VCC undervoltage lockout threshold ⁽³⁾ | | 1.7 | 2.5 | 2.9 | V |

(1) This parameter does not apply to the ISO1541 SCL1 line as it is unidirectional.

(2) $\Delta V_{OIT1} = V_{OL1} - V_{IHT1}$. This represents the minimum difference between a Low-Level Output Voltage and a High-Level Input Voltage Threshold to prevent a permanent latch condition that would otherwise exist with bidirectional communication.

(3) Any VCC voltages, on either side, less than the minimum will ensure device lockout. Both VCC voltages greater than the maximum will prevent device lockout.

6.10 Supply Current Characteristics

over recommended operating conditions, unless otherwise noted. For more information, see [Figure 7-1](#).

| PARAMETER | | TEST CONDITIONS | MIN | TYP | MAX | UNIT |
|---|---------------------|---|-----|-----|-----|------|
| 3 V ≤ VCC1, VCC2 ≤ 3.6 V | | | | | | |
| I _{CC1} Supply current, side 1 | ISO1540 | V _{SDA1} , V _{SCL1} = GND1; V _{SDA2} , V _{SCL2} = GND2; R1, R2 = Open; C1, C2 = Open | | 2.4 | 7.1 | mA |
| | | V _{SDA1} , V _{SCL1} = VCC1; V _{SDA2} , V _{SCL2} = VCC2; R1, R2 = Open; C1, C2 = Open | | 2.5 | 4 | |
| | ISO1541 | V _{SDA1} , V _{SCL1} = GND1; V _{SDA2} , V _{SCL2} = GND2; R1, R2 = Open; C1, C2 = Open | | 2.1 | 6.1 | |
| | | V _{SDA1} , V _{SCL1} = VCC1; V _{SDA2} , V _{SCL2} = VCC2; R1, R2 = Open; C1, C2 = Open | | 2.3 | 3.6 | |
| I _{CC2} Supply current, side 2 | ISO1540 and ISO1541 | V _{SDA1} , V _{SCL1} = GND1; V _{SDA2} , V _{SCL2} = GND2; R1, R2 = Open; C1, C2 = Open | | 1.7 | 6.7 | mA |
| | | V _{SDA1} , V _{SCL1} = VCC1; V _{SDA2} , V _{SCL2} = VCC2; R1, R2 = Open; C1, C2 = Open | | 1.9 | 3.5 | |
| 4.5 V ≤ VCC1, VCC2 ≤ 5.5 V | | | | | | |
| I _{CC1} Supply current, side 1 | ISO1540 | V _{SDA1} , V _{SCL1} = GND1; V _{SDA2} , V _{SCL2} = GND2; R1, R2 = Open; C1, C2 = Open | | 3.1 | 7.2 | mA |
| | | V _{SDA1} , V _{SCL1} = VCC1; V _{SDA2} , V _{SCL2} = VCC2; R1, R2 = Open; C1, C2 = Open | | 3.1 | 4.7 | |
| | ISO1541 | V _{SDA1} , V _{SCL1} = GND1; V _{SDA2} , V _{SCL2} = GND2; R1, R2 = Open; C1, C2 = Open | | 2.8 | 6.2 | |
| | | V _{SDA1} , V _{SCL1} = VCC1; V _{SDA2} , V _{SCL2} = VCC2; R1, R2 = Open; C1, C2 = Open | | 2.9 | 4.5 | |
| I _{CC2} Supply current, side 2 | ISO1540 and ISO1541 | V _{SDA1} , V _{SCL1} = GND1; V _{SDA2} , V _{SCL2} = GND2; R1, R2 = Open; C1, C2 = Open | | 2.3 | 6.8 | mA |
| | | V _{SDA1} , V _{SCL1} = VCC1; V _{SDA2} , V _{SCL2} = VCC2; R1, R2 = Open; C1, C2 = Open | | 2.5 | 4 | |

6.11 Timing Requirements

| | | MIN | NOM | MAX | UNIT | | |
|-------------------|---------------------------|--|-----|-----|------|-----|----|
| t _{UVLO} | Time to recover from UVLO | 2.7 V to 0.9 V; See Figure 7-4 | | 30 | 50 | 151 | μs |

6.12 Switching Characteristics

over recommended operating conditions, unless otherwise noted

| PARAMETER | | TEST CONDITIONS | MIN | TYP | MAX | UNIT | |
|------------------------------------|---|---|--|---------------------|-----|------|-----|
| 3 V ≤ VCC1, VCC2 ≤ 3.6 V | | | | | | | |
| t _{fr1} | Output Signal Fall Time (SDA1, SCL1) | See Figure 7-1 R1 = 953 Ω, C1 = 40 pF | 0.7 × VCC1 to 0.3 × VCC1 | 8 | 17 | 29 | ns |
| | | | 0.9 × VCC1 to 900 mV | 16 | 29 | 48 | |
| t _{fr2} | Output Signal Fall Time (SDA2, SCL2) | See Figure 7-1 R2 = 95.3 Ω, C2 = 400 pF | 0.7 × VCC2 to 0.3 × VCC2 | 14 | 23 | 47 | ns |
| | | | 0.9 × VCC2 to 400 mV | 35 | 50 | 100 | |
| t _{pLH1-2} | Low-to-High Propagation Delay, Side 1 to Side 2 | See Figure 7-1 R1 = 953 Ω, R2 = 95.3 Ω, C1, C2 = 10 pF | 0.55 V to 0.7 × VCC2 | | 33 | 65 | ns |
| t _{pHL1-2} | High-to-Low Propagation Delay, Side 1 to Side 2 | | 0.7 V to 0.4 V | | 90 | 181 | ns |
| PWD ₁₋₂ | Pulse Width Distortion t _{pHL1-2} - t _{pLH1-2} | | | | 55 | 123 | ns |
| t _{pLH2-1} ⁽¹⁾ | Low-to-High Propagation Delay, Side 2 to Side 1 | | 0.4 × VCC2 to 0.7 × VCC1 | | 47 | 68 | ns |
| t _{pHL2-1} ⁽¹⁾ | High-to-Low Propagation Delay, Side 2 to Side 1 | | 0.4 × VCC2 to 0.9 V | | 67 | 109 | ns |
| PWD ₂₋₁ ⁽¹⁾ | Pulse Width Distortion t _{pHL2-1} - t _{pLH2-1} | | | | 20 | 49 | ns |
| t _{LOOP1} ⁽¹⁾ | Round-trip propagation delay on Side 1 | | See Figure 7-2 ; R1 = 953 Ω, C1 = 40 pF R2 = 95.3 Ω, C2 = 400 pF | 0.4 V to 0.3 × VCC1 | | 100 | 165 |
| 4.5 V ≤ VCC1, VCC2 ≤ 5.5 V | | | | | | | |
| t _{fr1} | Output Signal Fall Time (SDA1, SCL1) | See Figure 7-1 R1 = 1430 Ω, C1 = 40 pF | 0.7 × VCC1 to 0.3 × VCC1 | 6 | 11 | 22 | ns |
| | | | 0.9 × VCC1 to 900 mV | 13 | 21 | 48 | |
| t _{fr2} | Output Signal Fall Time (SDA2, SCL2) | See Figure 7-1 R2 = 143 Ω, C2 = 400 pF | 0.7 × VCC2 to 0.3 × VCC2 | 10 | 18 | 35 | ns |
| | | | 0.9 × VCC2 to 400 mV | 28 | 41 | 76 | |
| t _{pLH1-2} | Low-to-High Propagation Delay, Side 1 to Side 2 | See Figure 7-1 R1 = 1430 Ω, R2 = 143 Ω, C1,2 = 10 pF | 0.55 V to 0.7 × VCC2 | | 31 | 62 | ns |
| t _{pHL1-2} | High-to-Low Propagation Delay, Side 1 to Side 2 | | 0.7 V to 0.4 V | | 70 | 139 | ns |
| PWD ₁₋₂ | Pulse Width Distortion t _{pHL1-2} - t _{pLH1-2} | | | | 38 | 80 | ns |
| t _{pLH2-1} ⁽¹⁾ | Low-to-high propagation delay, side 2 to side 1 | | 0.4 × VCC2 to 0.7 × VCC1 | | 55 | 80 | ns |
| t _{pHL2-1} ⁽¹⁾ | High-to-low propagation delay, Side 2 to side 1 | | 0.4 × VCC2 to 0.9 V | | 47 | 85 | ns |
| PWD ₂₋₁ ⁽¹⁾ | Pulse Width Distortion t _{pHL2-1} - t _{pLH2-1} | | | | 8 | 34 | ns |
| t _{LOOP1} ⁽¹⁾ | Round-trip propagation delay on side 1 | | See Figure 7-2 ; R1 = 1430 Ω, C1 = 40 pF R2 = 143 Ω, C2 = 400 pF | 0.4 V to 0.3 × VCC1 | | 110 | 180 |

(1) This parameter does not apply to the ISO1541 SCL1 line as it is unidirectional.

6.13 Insulation Characteristics Curves

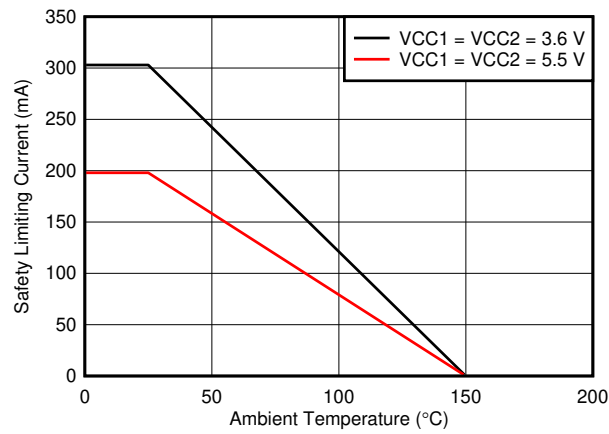

Figure 6-1. Thermal Derating Curve for Limiting Current per VDE

6.14 Typical Characteristics

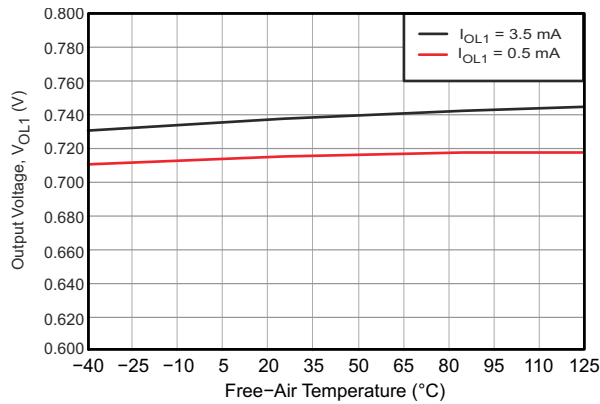

Figure 6-2. Side 1: Output Low Voltage vs Free-Air Temperature

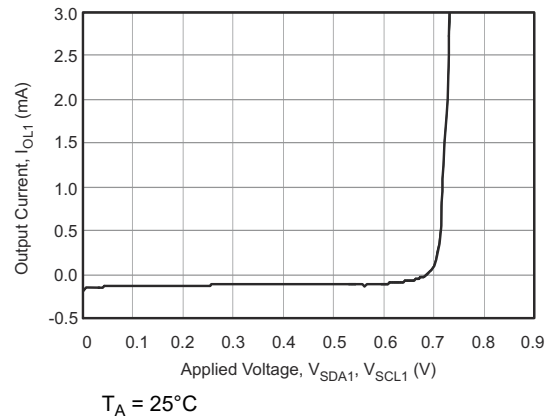

Figure 6-3. Side 1: Output Low Current vs S_{DA1} or S_{CL1} Applied Voltage

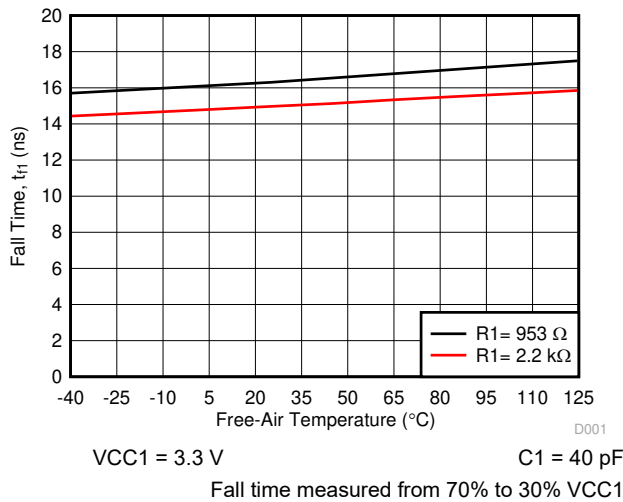

Figure 6-4. Side 1: Output Fall Time vs Free-Air Temperature

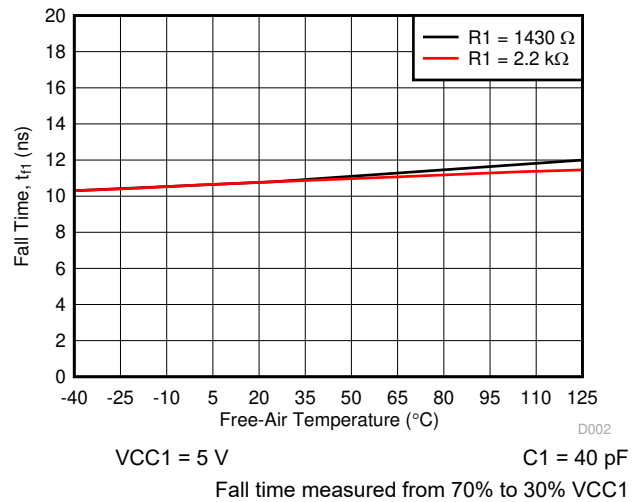

Figure 6-5. Side 1: Output Fall Time vs Free-air Temperature

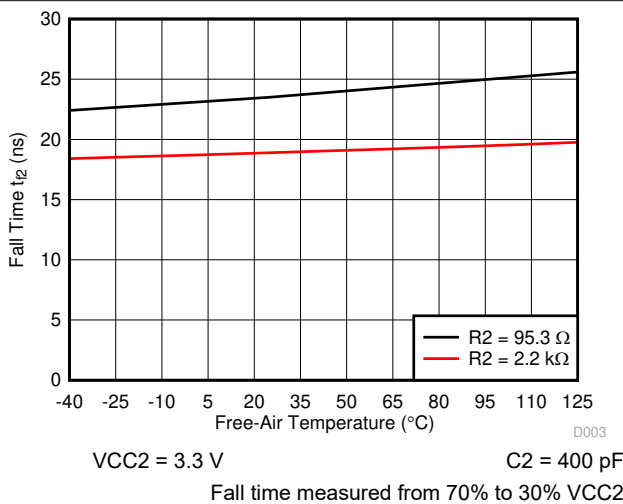

Figure 6-6. Side 2: Output Fall Time vs Free-Air Temperature

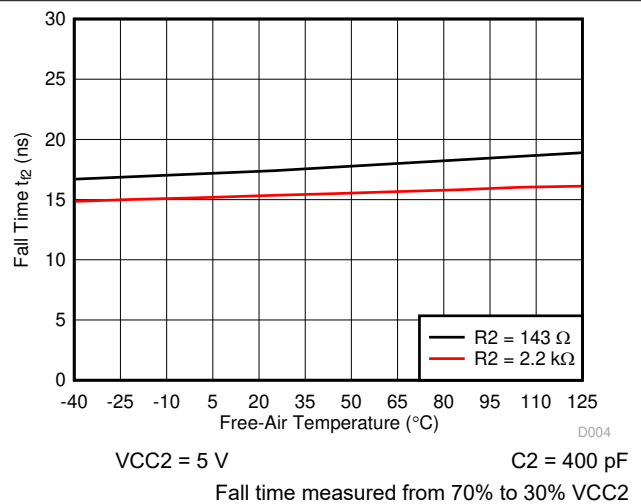
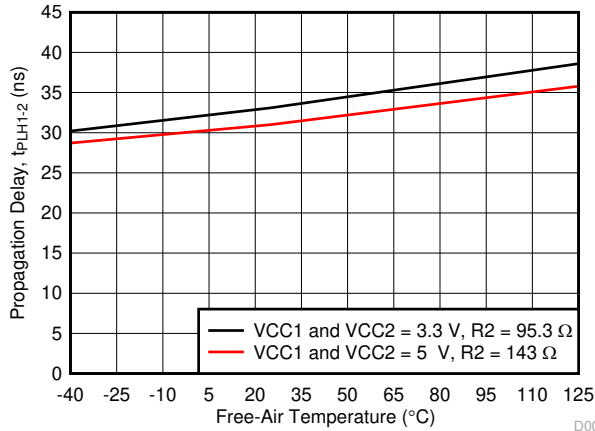
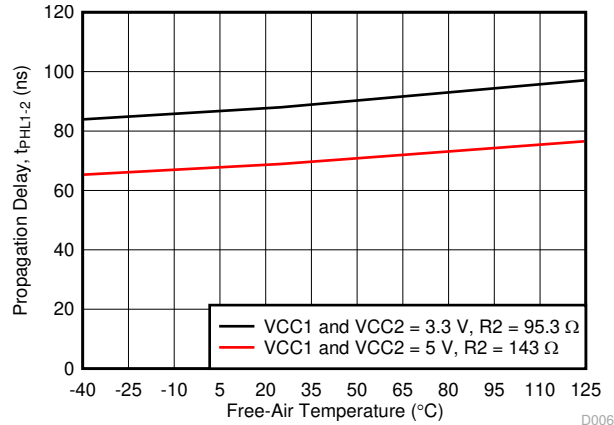

Figure 6-7. Side 2: Output Fall Time vs Free-Air Temperature



C2 = 10 pF

Figure 6-8. t_{PLH1-2} Propagation Delay vs Free-Air Temperature



C2 = 10 pF

Figure 6-9. t_{PHL1-2} Propagation Delay vs Free-Air Temperature

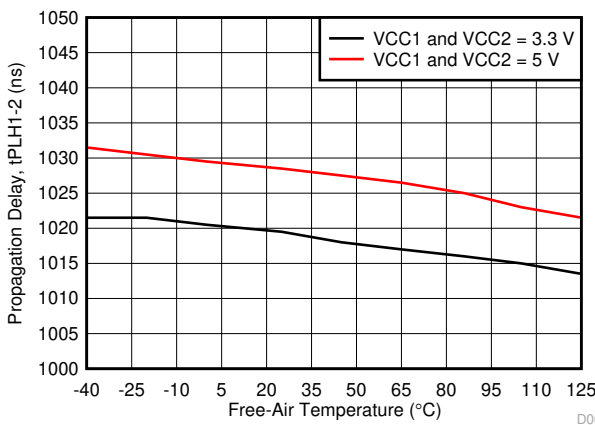

R2 = 2.2 kΩ C2 = 400 pF

Figure 6-10. t_{PLH1-2} Propagation Delay vs Free-Air Temperature

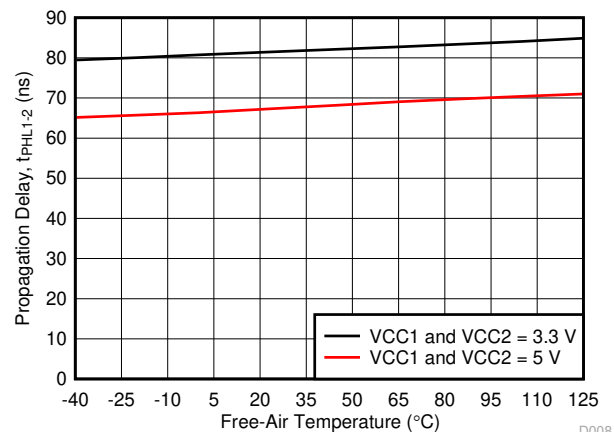

R2 = 2.2 kΩ C2 = 400 pF

Figure 6-11. t_{PHL1-2} Propagation Delay vs Free-Air Temperature

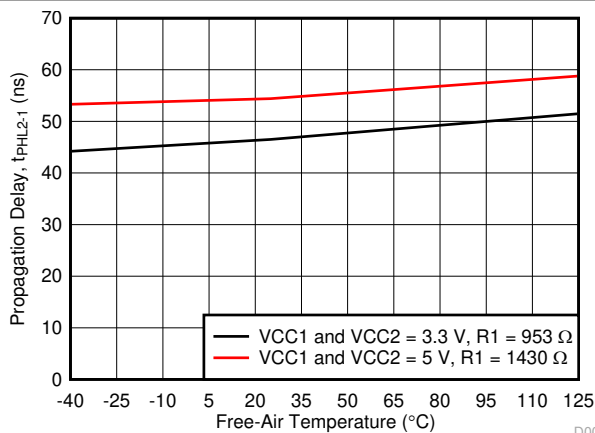

C1 = 10 pF

Figure 6-12. t_{PLH2-1} Propagation Delay vs Free-Air Temperature

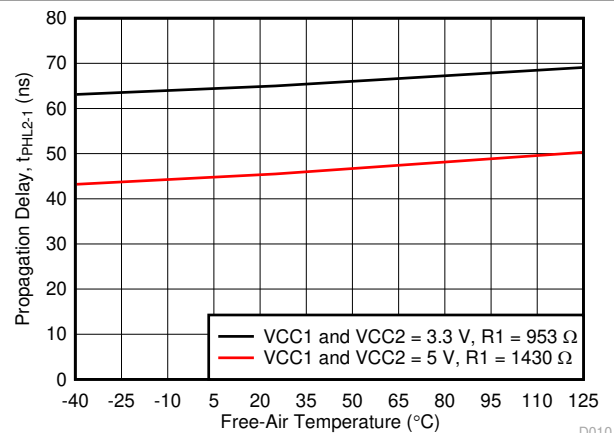

C1 = 10 pF

Figure 6-13. t_{PHL2-1} Propagation Delay vs Free-Air Temperature

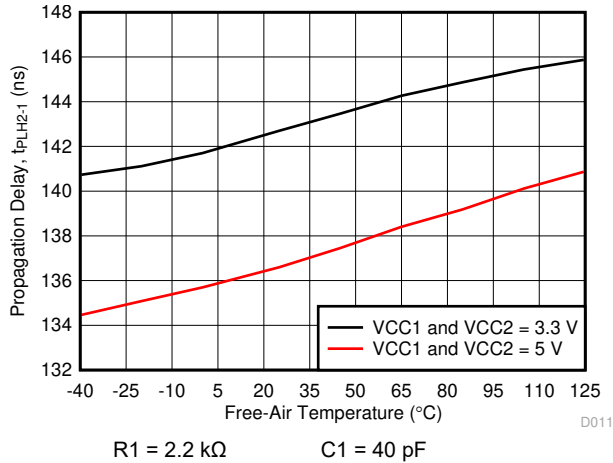

Figure 6-14. t_{PLH2-1} Propagation Delay vs Free-Air Temperature

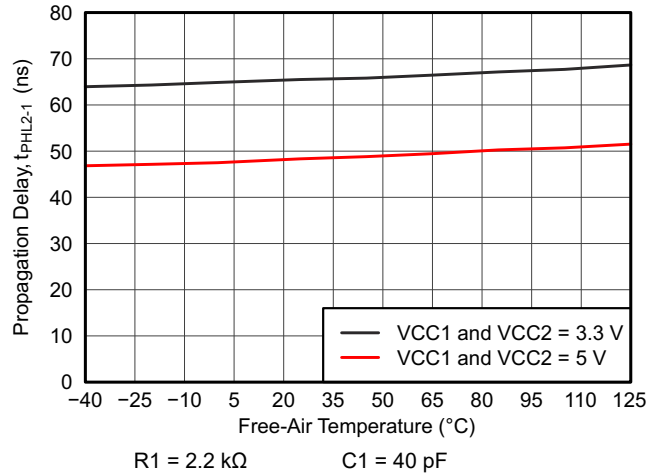

Figure 6-15. t_{PHL2-1} Propagation Delay vs Free-Air Temperature

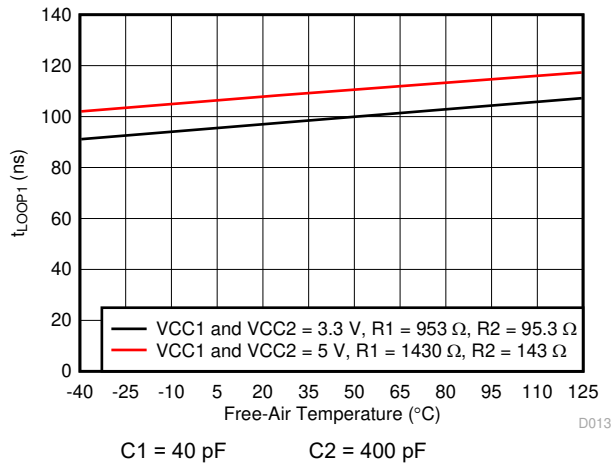

Figure 6-16. t_{LOOP1} vs Free-Air Temperature

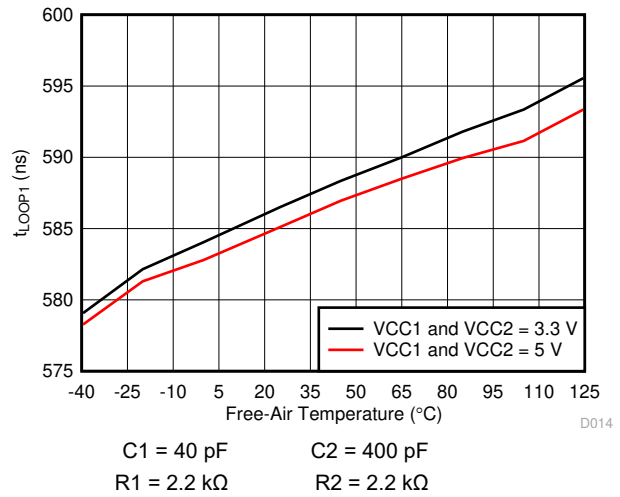

Figure 6-17. t_{LOOP1} vs Free-Air Temperature

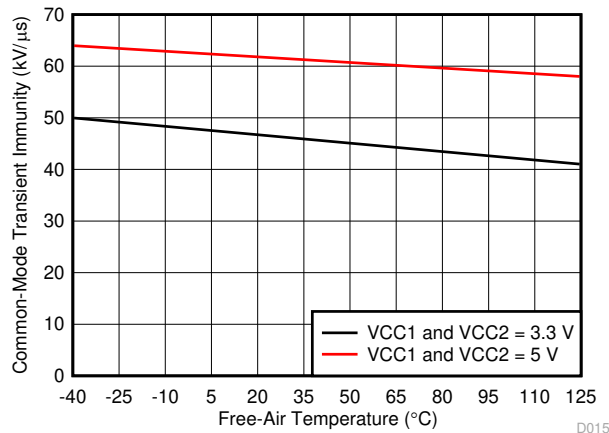
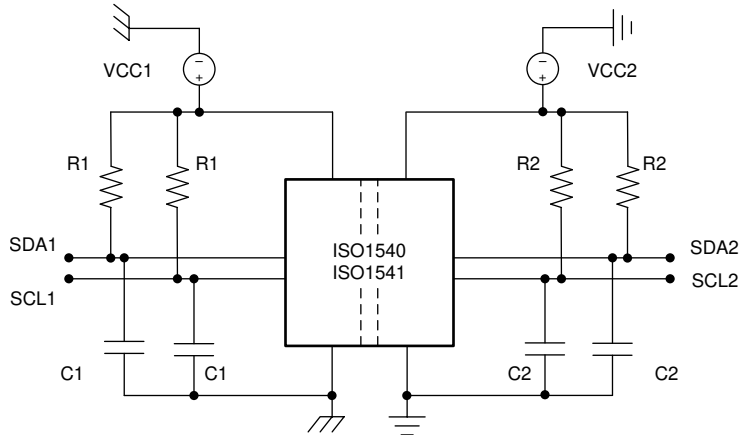

Figure 6-18. CMTI vs Free-Air Temperature

Parameter Measurement Information



Copyright © 2016, Texas Instruments Incorporated

Figure 7-1. Test Diagram

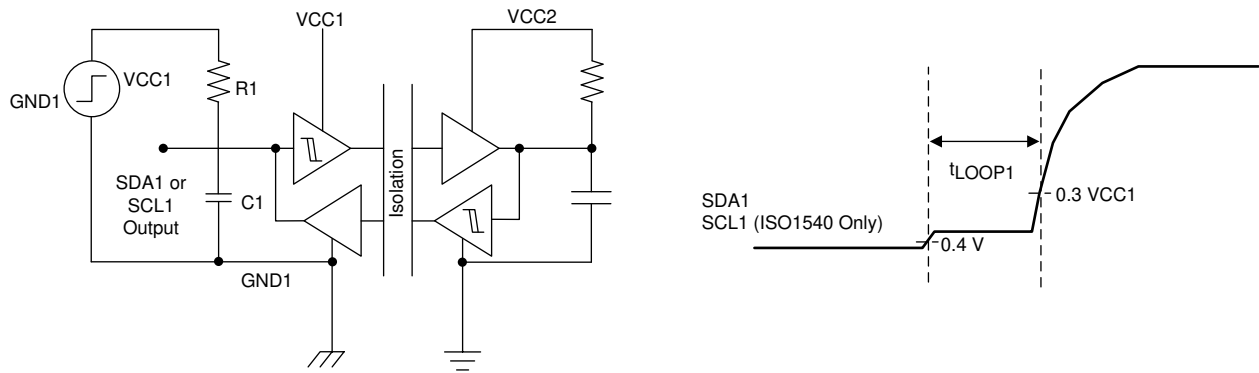

Copyright © 2016, Texas Instruments Incorporated

Figure 7-2. t_{LOOP1} Setup and Timing Diagram

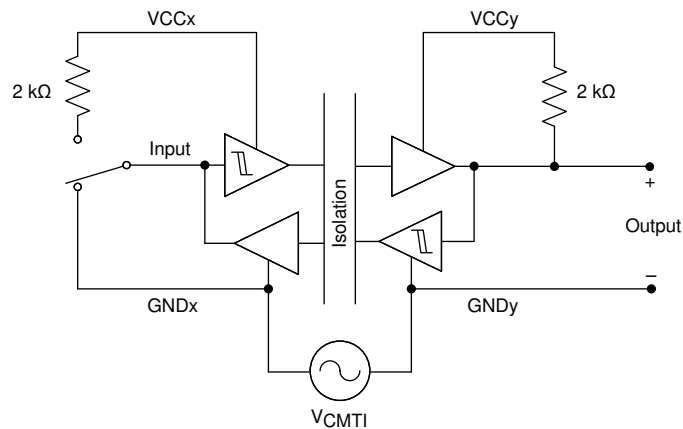
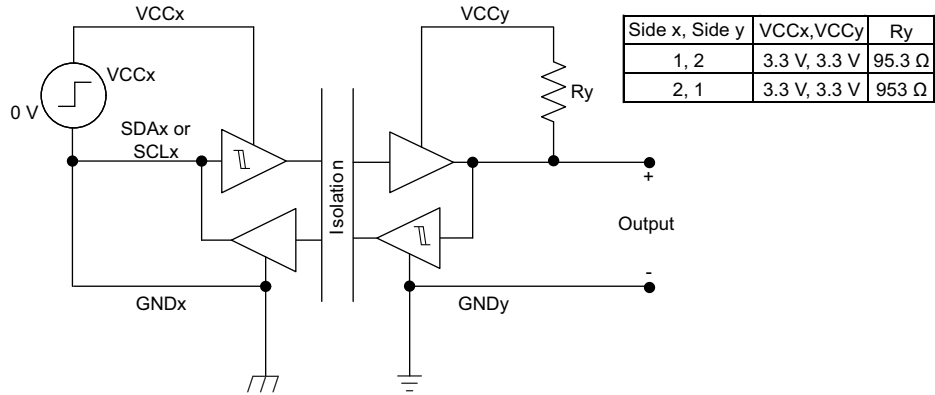

Figure 7-3. Common-Mode Transient Immunity Test Circuit



or

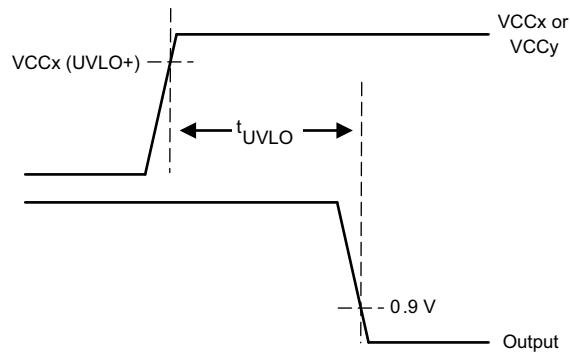
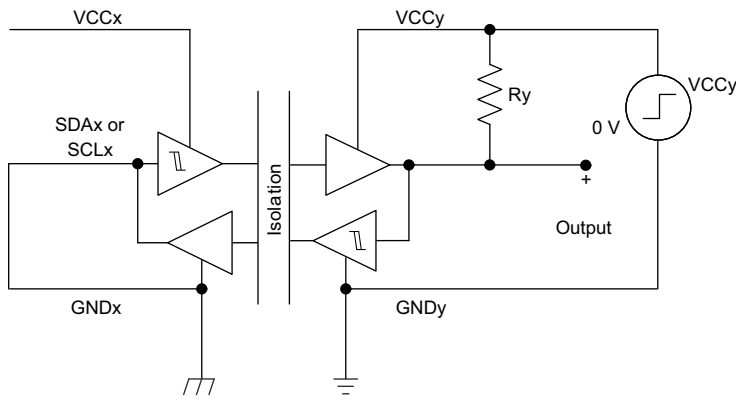

Figure 7-4. t_{UVLO} Test Circuit and Timing Diagrams

7 Detailed Description

7.1 Overview

The I²C bus is used in a wide range of applications because it is simple to use. The bus consists of a two-wire communication bus that supports bidirectional data transfer between a controller device and several target devices. The controller, or processor, controls the bus, specifically the serial clock (SCL) line. Data is transferred between the controller and target through a serial data (SDA) line. This data can be transferred in four speeds: standard mode (0 to 100 kbps), fast mode (0 to 400 kbps), fast-mode plus (0 to 1 Mbps), and high-speed mode (0 to 3.4 Mbps). The most common speeds are the standard and fast modes.

The I²C bus operates in bidirectional, half-duplex mode, while standard digital isolators are unidirectional devices. To make efficient use of one technology supporting the other, external circuitry is required that separates the bidirectional bus into two unidirectional signal paths without introducing significant propagation delay. These devices have their logic input and output buffers separated by TI's capacitive isolation technology using a silicon dioxide (SiO₂) barrier. When used in conjunction with isolated power supplies, these devices block high voltages, isolate grounds, and prevent noise currents from entering the local ground and interfering with or damaging sensitive circuitry.

7.2 Functional Block Diagrams

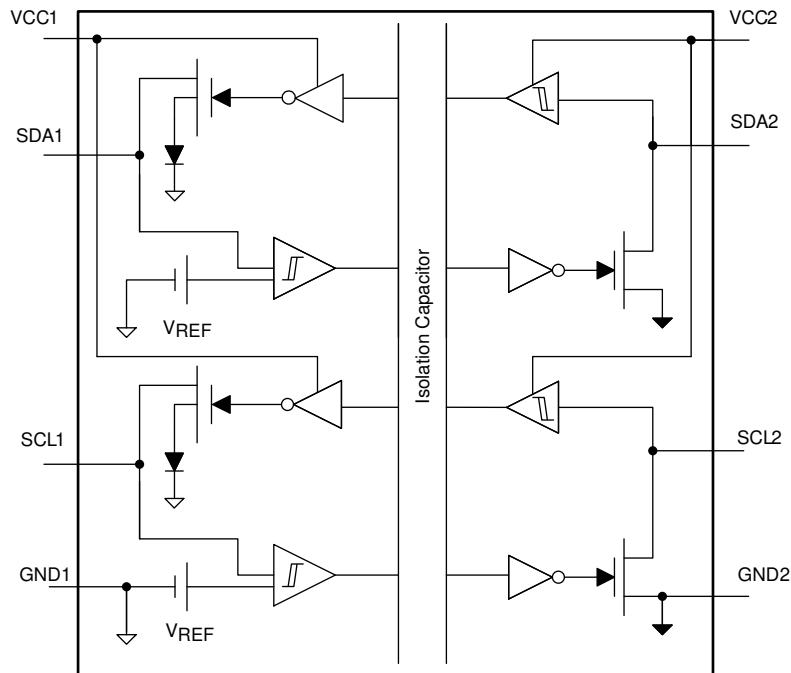

Figure 7-1. ISO1540 Block Diagram

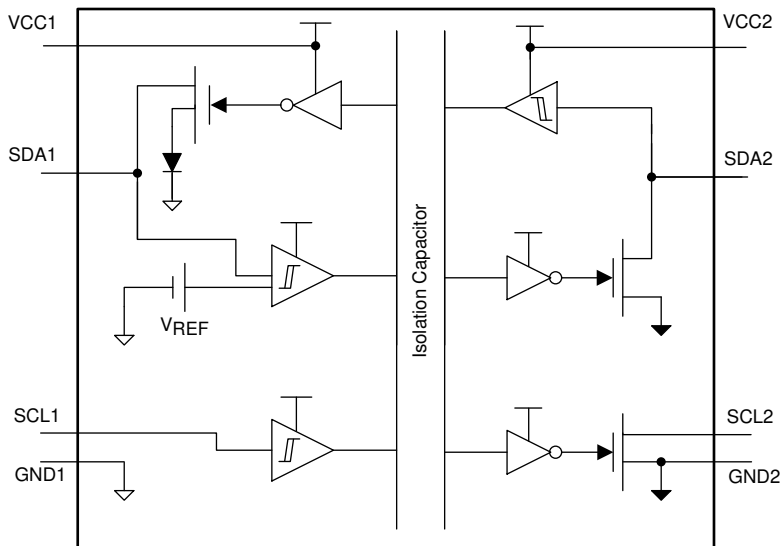

Figure 7-2. ISO1541 Block Diagram

7.3 Feature Description

The device enables a complete isolated I²C interface to be implemented within a small form factor having the features listed in Table 7-1.

Table 7-1. Features List

| PART NUMBER | CHANNEL DIRECTION | RATED ISOLATION ⁽¹⁾ | MAXIMUM FREQUENCY |
|-------------|---|---|-------------------|
| ISO1540 | Bidirectional (SCL) Bidirectional (SDA) | 2500 V _{RMS} 4242 V _{PK} | 1 MHz |
| ISO1541 | Unidirectional (SCL) Bidirectional (SDA) | | |

(1) See Section 6.7 for detailed Isolation specifications.

7.4 Isolator Functional Principle

To isolate a bidirectional signal path (SDA or SCL), the ISO1540 internally splits a bidirectional line into two unidirectional signal lines, each of which is isolated through a single-channel digital isolator. Each channel output is made open-drain to comply with the open-drain technology of I²C. Side 1 of the ISO1540 connects to a low-capacitance I²C node, while side 2 is designed for connecting to a fully loaded I²C bus with up to 400 pF of capacitance.

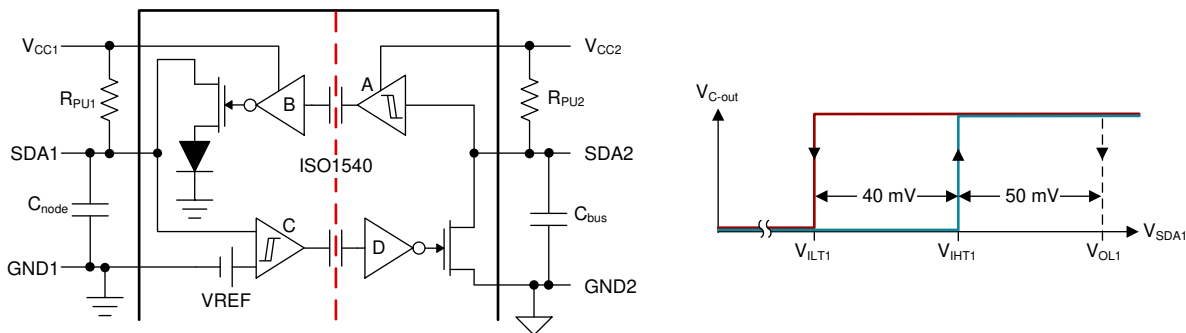

Figure 7-3. SDA Channel Design and Voltage Levels at SDA1

At first sight, the arrangement of the internal buffers suggests a closed signal loop that is prone to latch-up. However, this loop is broken by implementing an output buffer (B) whose output low-level is raised by a diode drop to approximately 0.75 V, and the input buffer (C) that consists of a comparator with defined hysteresis.

The comparator's upper and lower input thresholds then distinguish between the proper low-potential of 0.4 V (maximum) driven directly by SDA1 and the buffered output low-level of B.

Figure 7-4 demonstrate the switching behavior of the I²C isolator, ISO1540, between a controller node at SDA1 and a heavy loaded bus at SDA2.

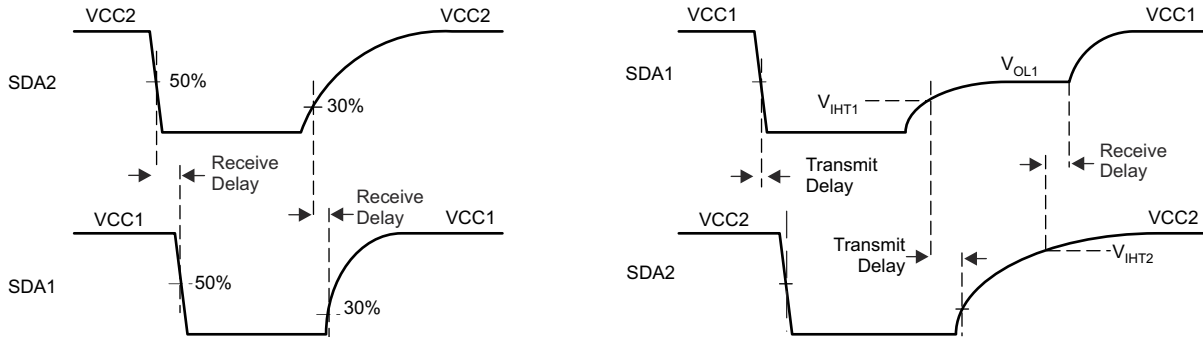

Figure 7-4. SDA Channel Timing in Receive and Transmit Directions

7.4.1 Receive Direction (Left Diagram of)

When the I²C bus drives SDA2 low, SDA1 follows after a certain delay in the receive path. The output low is the buffered output of $V_{OL1} = 0.75\text{ V}$, which is sufficiently low to be detected by Schmitt-trigger inputs with a minimum input-low voltage of $V_{IL} = 0.9\text{ V}$ at 3 V supply levels.

When SDA2 is released, its voltage potential increases towards V_{CC2} following the time-constant formed by R_{PU2} and C_{bus} . After the receive delay, SDA1 is released and also rises towards V_{CC1} , following the time-constant $R_{PU1} \times C_{node}$. Because of the significant lower time-constant, SDA1 may reach V_{CC1} before SDA2 reaches V_{CC2} potential.

7.4.2 Transmit Direction (Right Diagram of)

When a controller drives SDA1 low, SDA2 follows after a certain delay in the transmit direction. When SDA2 turns low it also causes the output of buffer B to turn low but at a higher 0.75 V level. This level cannot be observed immediately as it is overwritten by the lower low-level of the controller.

However, when the controller releases SDA1, the voltage potential increases and first must pass the upper input threshold of the comparator, V_{IHT1} , to release SDA2. SDA1 then increases further until it reaches the buffered output level of $V_{OL1} = 0.75\text{ V}$, maintained by the receive path. When comparator C turns high, SDA2 is released after the delay in transmit direction. It takes another receive delay until B's output turns high and fully releases SDA1 to move toward V_{CC1} potential.

7.5 Device Functional Modes

Table 7-2 lists the ISO154x functional modes.

Table 7-2. Function Table

| POWER STATE | INPUT | OUTPUT |
|--|------------------|--------|
| V_{CC1} or $V_{CC2} < 2.1\text{ V}$ | X | Z |
| V_{CC1} and $V_{CC2} > 2.8\text{ V}$ | L | L |
| V_{CC1} and $V_{CC2} > 2.8\text{ V}$ | H | Z |
| V_{CC1} and $V_{CC2} > 2.8\text{ V}$ | Z ⁽¹⁾ | ? |

(1) Invalid input condition as an I²C system requires that a pullup resistor to VCC is connected.

8 Application and Implementation

Note

Information in the following applications sections is not part of the TI component specification, and TI does not warrant its accuracy or completeness. TI's customers are responsible for determining suitability of components for their purposes. Customers should validate and test their design implementation to confirm system functionality.

8.1 Application Information

8.1.1 I²C Bus Overview

The inter-integrated circuit (I²C) bus is a single-ended, multi-controller, 2-wire bus for efficient inter-IC communication in half-duplex mode.

I²C uses open-drain technology, requiring two lines, serial data (SDA) and serial clock (SCL), to be connected to VDD by resistors (see Figure 8-1). Pulling the line to ground is considered a logic zero while letting the line float is a logic one. This logic is used as a channel access method. Transitions of logic states must occur while the SCL pin is low. Transitions while the SCL pin is high indicate START and STOP conditions. Typical supply voltages are 3.3 V and 5 V, although systems with higher or lower voltages are allowed.

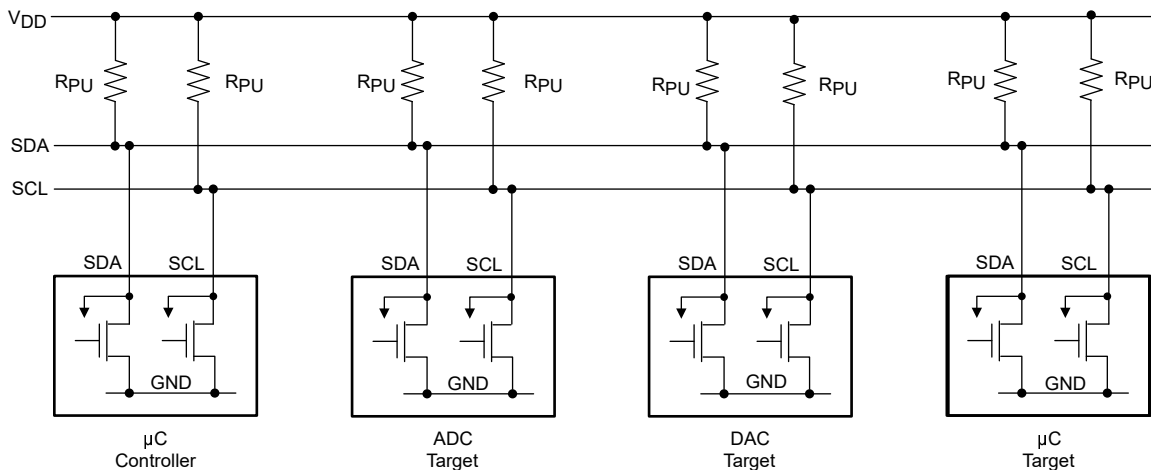

Figure 8-1. I²C Bus

I²C communication uses a 7-bit address space with 16 reserved addresses, so a theoretical maximum of 112 nodes can communicate on the same bus. In praxis, however, the number of nodes is limited by the specified, total bus capacitance of 400 pF, which restricts communication distances to a few meters.

The specified signaling rates for the ISO1540 and ISO1541 devices are 100 kbps (standard mode), 400 kbps (fast mode), 1 Mbps (fast mode plus).

The bus has two roles for nodes: controller and target. A controller node issues the clock and target addresses, and also initiates and ends data transactions. A target node receives the clock and addresses and responds to requests from the controller. Figure 8-2 shows a typical data transfer between controller and target.

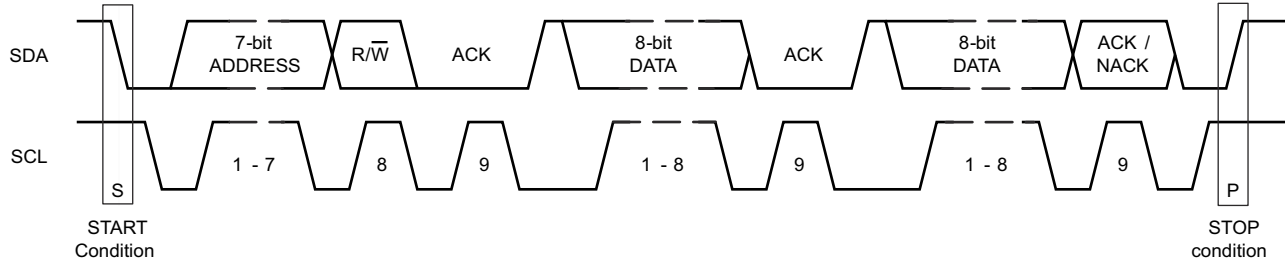

Figure 8-2. Timing Diagram of a Complete Data Transfer

The controller initiates a transaction by creating a START condition, following by the 7-bit address of the target it wishes to communicate with. This is followed by a single read and write (R/W) bit, representing whether the controller wishes to write to 0, or to read from 1 the target. The controller then releases the SDA line to allow the target to acknowledge the receipt of data.

The target responds with an acknowledge bit (ACK) by pulling the SDA pin low during the entire high time of the 9th clock pulse on the SCL signal, after which the controller continues in either transmit or receive mode (according to the R/W bit sent), while the target continues in the complementary mode (receive or transmit, respectively).

The address and the 8-bit data bytes are sent most significant bit (MSB) first. The START bit is indicated by a high-to-low transition of SDA while SCL is high. The STOP condition is created by a low-to-high transition of SDA while SCL is high.

If the controller writes to a target, it repeatedly sends a byte with the target sending an ACK bit. In this case, the controller is in controller-transmit mode and the target is in target-receive mode.

If the controller reads from a target, it repeatedly receives a byte from the target, while acknowledging (ACK) the receipt of every byte but the last one (see Figure 8-3). In this situation, the controller is in controller-receive mode and the target is in target-transmit mode.

The controller ends the transmission with a STOP bit, or may send another START bit to maintain bus control for further transfers.

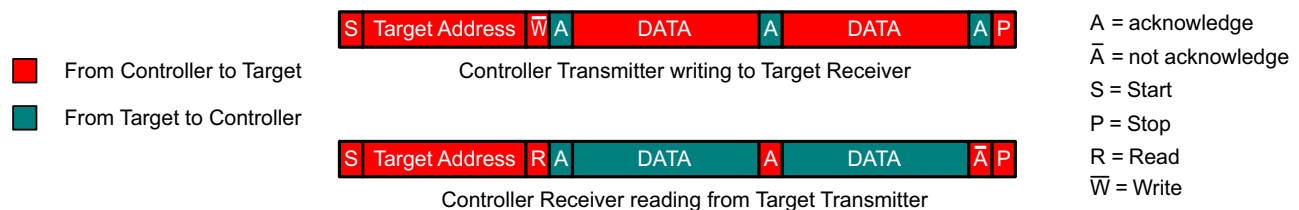

Figure 8-3. Transmit or Receive Mode Changes During a Data Transfer

When writing to a target, a controller mainly operates in transmit-mode and only changes to receive-mode when receiving acknowledgment from the target.

When reading from a target, the controller starts in transmit-mode and then changes to receive-mode after sending a READ request (R/W bit = 1) to the target. The target continues in the complementary mode until the end of a transaction.

Note

The controller ends a reading sequence by not acknowledging (NACK) the last byte received. This procedure resets the target state machine and allows the controller to send the STOP command.

8.2 Typical Application

In Figure 8-4, the ultra low-power microcontroller, MSP430G2132, controls the I²C data traffic of configuration data and conversion results for the analog inputs and outputs. Low-power data converters build the analog

interface to sensors and actuators. The ISO1541 device provides the required isolation between different ground potentials of the system controller, remote sensor, and actuator circuitry to prevent ground loop currents that otherwise may falsify the acquired data.

The entire circuit operates from a single 3.3-V supply. A low-power push-pull converter, SN6501, drives a center-tapped transformer with an output that is rectified and linearly regulated to provide a stable 5-V supply for the data converter.

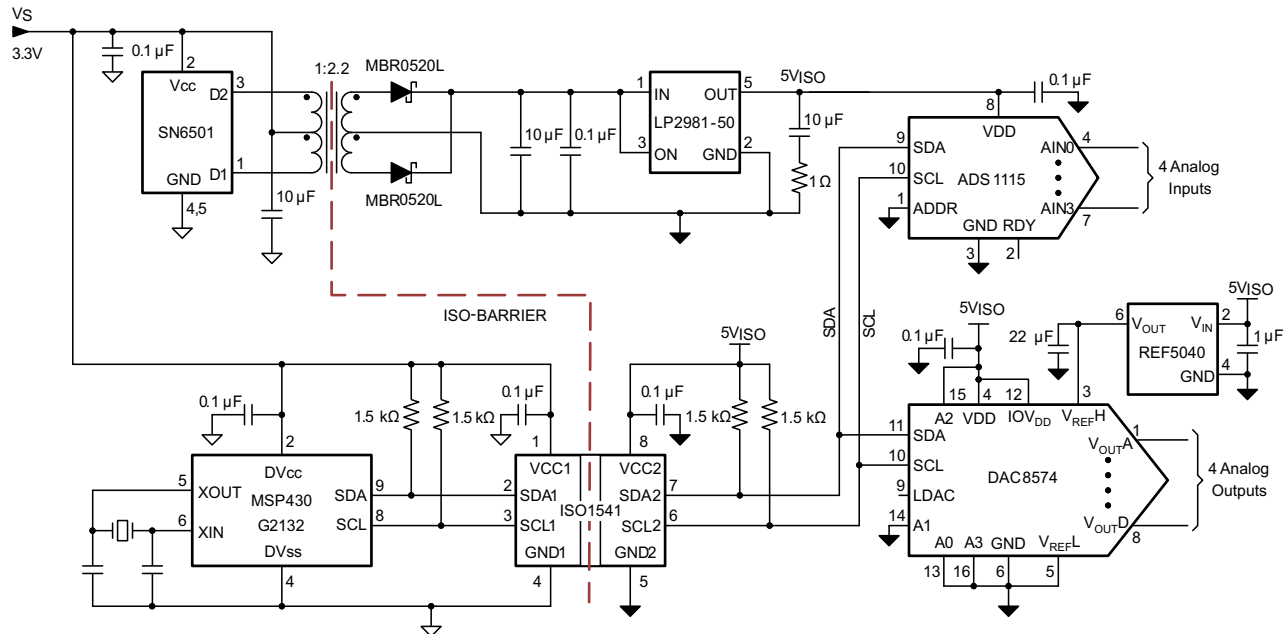

Copyright © 2016, Texas Instruments Incorporated

Figure 8-4. Isolated I²C Data Acquisition System

8.2.1 Design Requirements

The recommended power supply voltages (VCC1 and VCC2) must be from 3 V to 5.5 V. A recommended decoupling capacitor with a value of 0.1 µF is required between both the VCC1 and GND1 pins, and the VCC2 and GND2 pins to support of power supply voltages transient and to ensure reliable operation at all data rates.

8.2.2 Detailed Design Procedure

The power-supply capacitor with a value of 0.1-µF must be placed as close to the power supply pins as possible. The recommended placement of the capacitors must be 2-mm maximum from input and output power supply pins (VCC1 and VCC2).

The maximum load permissible on the input lines, SDA1 and SCL1, is ≤ 40 pF and on the output lines, SDA2 and SCL2, is ≤ 400 pF.

The minimum pullup resistors on the input lines, SDA1 and SCL1 to VCC1 must be selected in such a way that input current drawn is ≤ 3.5 mA. The minimum pullup resistors on the input lines, SDA2 and SCL2, to VCC2 must be selected in such a way that output current drawn is ≤ 35 mA. The maximum pullup resistors on the input

lines (SDA1 and SCL1) to VCC1 and on output lines (SDA1 and SCL1) to VCC2, depends on the load and rise time requirements on the respective lines.

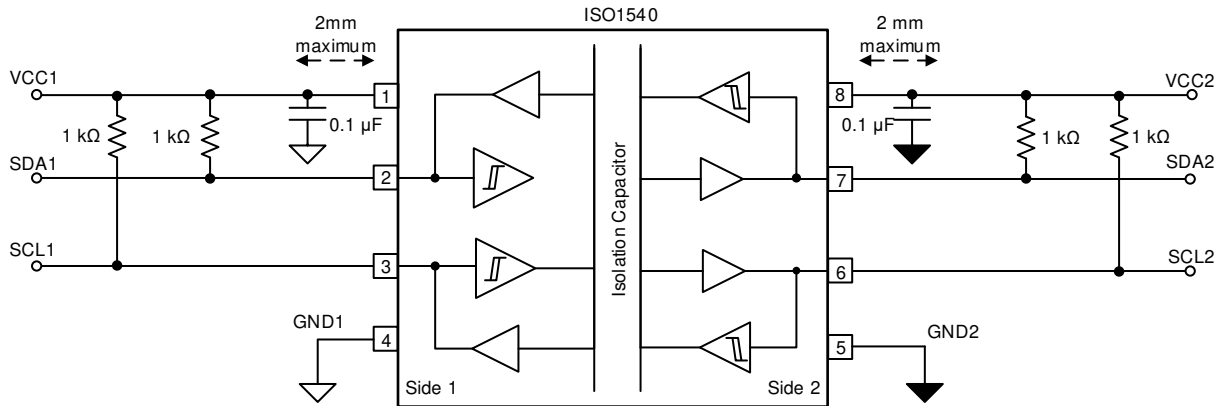

Figure 8-5. Typical ISO1540 Circuit Hookup

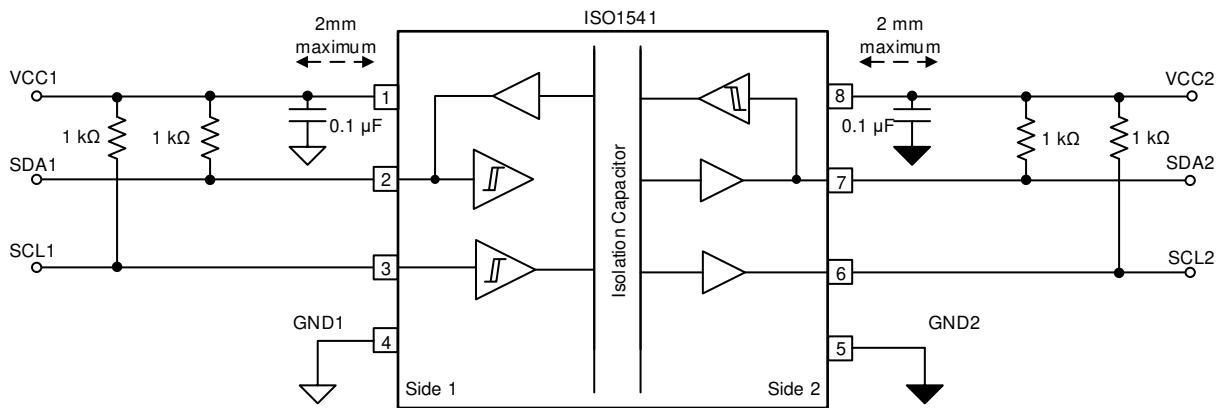

Figure 8-6. Typical ISO1541 Circuit Hookup

8.2.3 Application Curve

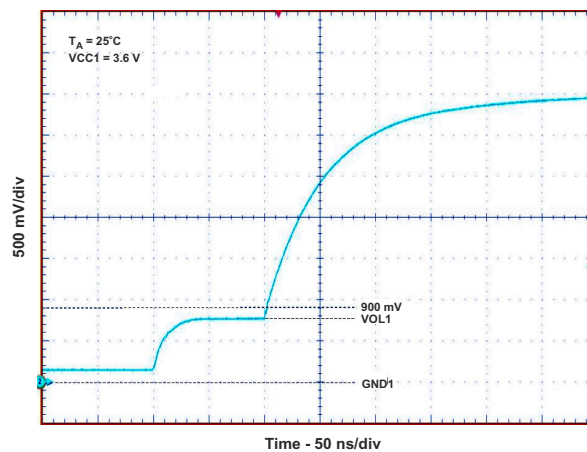

Figure 8-7. Side 1: Low-to-High Transition

9 Power Supply Recommendations

To help ensure reliable operation at data rates and supply voltages, TI recommends connecting a 0.1-μF bypass capacitor at the input and output supply pins (VCC1 and VCC2). The capacitors should be placed as close to the supply pins as possible. If only a single, primary-side power supply is available in an application, isolated power

can be generated for the secondary-side with the help of a transformer driver such as TI's [SN6501](#) device. For such applications, detailed power supply design and transformer selection recommendations are available in [SN6501 Transformer Driver for Isolated Power Supplies](#). (SLLSEA0).

10 Layout

10.1 Layout Guidelines

A minimum of four layers is required to accomplish a low EMI PCB design (see [Figure 10-1](#)). Layer stacking should be in the following order (top-to-bottom): high-speed signal layer, ground plane, power plane and low-frequency signal layer.

- Routing the high-speed traces on the top layer avoids the use of vias (and the introduction of their inductances) and allows for clean interconnects between the isolator and the transmitter and receiver circuits of the data link.
- Placing a solid ground plane next to the high-speed signal layer establishes controlled impedance for transmission line interconnects and provides an excellent low-inductance path for the return current flow.
- Placing the power plane next to the ground plane creates additional high-frequency bypass capacitance of approximately 100 pF/in².
- Routing the slower speed control signals on the bottom layer allows for greater flexibility as these signal links usually have margin to tolerate discontinuities such as vias.

If an additional supply voltage plane or signal layer is needed, add a second power or ground plane system to the stack to keep it symmetrical. This makes the stack mechanically stable and prevents it from warping. Also the power and ground plane of each power system can be placed closer together, thus increasing the high-frequency bypass capacitance significantly.

For detailed layout recommendations, see the [Digital Isolator Design Guide](#) (SLLA284)

10.1.1 PCB Material

For digital circuit boards operating at less than 150 Mbps, (or rise and fall times greater than 1 ns), and trace lengths of up to 10 inches, use standard FR-4 UL94V-0 printed circuit board. This PCB is preferred over cheaper alternatives because of lower dielectric losses at high frequencies, less moisture absorption, greater strength and stiffness, and the self-extinguishing flammability-characteristics.

10.2 Layout Example

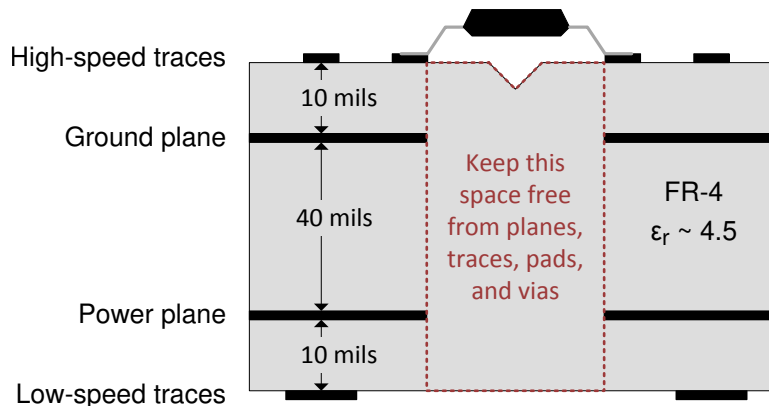

Figure 10-1. Recommended Layer Stack

11 Device and Documentation Support

11.1 Documentation Support

Note

TI is transitioning to use more inclusive terminology. Some language may be different than what you would expect to see for certain technology areas.

11.1.1 Related Documentation

For related documentation see the following:

- [Digital Isolator Design Guide](#) (SLLA284)
- [ISO154xEVM Low-Power Bidirectional I²C Isolators Evaluation Module](#) (SLLU166)
- [TI Isolation Glossary](#) (SLLA353)
- [SN6501 Transformer Driver for Isolated Power Supplies](#). (SLLSEA0)

11.2 Related Links

The table below lists quick access links. Categories include technical documents, support and community resources, tools and software, and quick access to sample or buy.

Table 11-1. Related Links

| PARTS | PRODUCT FOLDER | SAMPLE & BUY | TECHNICAL DOCUMENTS | TOOLS & SOFTWARE | SUPPORT & COMMUNITY |
|---------|----------------------------|----------------------------|----------------------------|----------------------------|----------------------------|
| ISO1540 | Click here | Click here | Click here | Click here | Click here |
| ISO1541 | Click here | Click here | Click here | Click here | Click here |

11.3 Receiving Notification of Documentation Updates

To receive notification of documentation updates, navigate to the device product folder on ti.com. In the upper right corner, click on *Alert me* to register and receive a weekly digest of any product information that has changed. For change details, review the revision history included in any revised document.

11.4 Community Resources

11.5 Trademarks

All trademarks are the property of their respective owners.

12 Mechanical, Packaging, and Orderable Information

The following pages include mechanical, packaging, and orderable information. This information is the most current data available for the designated devices. This data is subject to change without notice and revision of this document. For browser-based versions of this data sheet, refer to the left-hand navigation.

PACKAGING INFORMATION

| Orderable Device | Status (1) | Package Type | Package Drawing | Pins | Package Qty | Eco Plan (2) | Lead finish/ Ball material (6) | MSL Peak Temp (3) | Op Temp (°C) | Device Marking (4/5) | Samples |
|------------------|---------------|--------------|-----------------|------|-------------|-----------------|--------------------------------------|----------------------|--------------|-------------------------|-------------------------|
| ISO1540D | ACTIVE | SOIC | D | 8 | 75 | RoHS & Green | NIPDAU | Level-2-260C-1 YEAR | -40 to 125 | IS1540 | Samples |
| ISO1540DR | ACTIVE | SOIC | D | 8 | 2500 | RoHS & Green | NIPDAU | Level-2-260C-1 YEAR | -40 to 125 | IS1540 | Samples |
| ISO1541D | ACTIVE | SOIC | D | 8 | 75 | RoHS & Green | NIPDAU | Level-2-260C-1 YEAR | -40 to 125 | IS1541 | Samples |
| ISO1541DR | ACTIVE | SOIC | D | 8 | 2500 | RoHS & Green | NIPDAU | Level-2-260C-1 YEAR | -40 to 125 | IS1541 | Samples |

(1) The marketing status values are defined as follows:

ACTIVE: Product device recommended for new designs.

LIFEBUY: TI has announced that the device will be discontinued, and a lifetime-buy period is in effect.

NRND: Not recommended for new designs. Device is in production to support existing customers, but TI does not recommend using this part in a new design.

PREVIEW: Device has been announced but is not in production. Samples may or may not be available.

OBSOLETE: TI has discontinued the production of the device.

(2) **RoHS:** TI defines "RoHS" to mean semiconductor products that are compliant with the current EU RoHS requirements for all 10 RoHS substances, including the requirement that RoHS substance do not exceed 0.1% by weight in homogeneous materials. Where designed to be soldered at high temperatures, "RoHS" products are suitable for use in specified lead-free processes. TI may reference these types of products as "Pb-Free".

RoHS Exempt: TI defines "RoHS Exempt" to mean products that contain lead but are compliant with EU RoHS pursuant to a specific EU RoHS exemption.

Green: TI defines "Green" to mean the content of Chlorine (Cl) and Bromine (Br) based flame retardants meet JS709B low halogen requirements of <=1000ppm threshold. Antimony trioxide based flame retardants must also meet the <=1000ppm threshold requirement.

(3) MSL, Peak Temp. - The Moisture Sensitivity Level rating according to the JEDEC industry standard classifications, and peak solder temperature.

(4) There may be additional marking, which relates to the logo, the lot trace code information, or the environmental category on the device.

(5) Multiple Device Markings will be inside parentheses. Only one Device Marking contained in parentheses and separated by a "-" will appear on a device. If a line is indented then it is a continuation of the previous line and the two combined represent the entire Device Marking for that device.

(6) Lead finish/Ball material - Orderable Devices may have multiple material finish options. Finish options are separated by a vertical ruled line. Lead finish/Ball material values may wrap to two lines if the finish value exceeds the maximum column width.

Important Information and Disclaimer:The information provided on this page represents TI's knowledge and belief as of the date that it is provided. TI bases its knowledge and belief on information provided by third parties, and makes no representation or warranty as to the accuracy of such information. Efforts are underway to better integrate information from third parties. TI has taken and

continues to take reasonable steps to provide representative and accurate information but may not have conducted destructive testing or chemical analysis on incoming materials and chemicals. TI and TI suppliers consider certain information to be proprietary, and thus CAS numbers and other limited information may not be available for release.

In no event shall TI's liability arising out of such information exceed the total purchase price of the TI part(s) at issue in this document sold by TI to Customer on an annual basis.

OTHER QUALIFIED VERSIONS OF ISO1540, ISO1541 :

- Automotive : [ISO1540-Q1](#), [ISO1541-Q1](#)

NOTE: Qualified Version Definitions:

- Automotive - Q100 devices qualified for high-reliability automotive applications targeting zero defects

TAPE AND REEL INFORMATION

QUADRANT ASSIGNMENTS FOR PIN 1 ORIENTATION IN TAPE

*All dimensions are nominal

| Device | Package Type | Package Drawing | Pins | SPQ | Reel Diameter (mm) | Reel Width W1 (mm) | A0 (mm) | B0 (mm) | K0 (mm) | P1 (mm) | W (mm) | Pin1 Quadrant |
|-----------|--------------|-----------------|------|------|--------------------|--------------------|---------|---------|---------|---------|--------|---------------|
| ISO1540DR | SOIC | D | 8 | 2500 | 330.0 | 12.4 | 6.4 | 5.2 | 2.1 | 8.0 | 12.0 | Q1 |
| ISO1541DR | SOIC | D | 8 | 2500 | 330.0 | 12.4 | 6.4 | 5.2 | 2.1 | 8.0 | 12.0 | Q1 |

TAPE AND REEL BOX DIMENSIONS

*All dimensions are nominal

| Device | Package Type | Package Drawing | Pins | SPQ | Length (mm) | Width (mm) | Height (mm) |
|-----------|--------------|-----------------|------|------|-------------|------------|-------------|
| ISO1540DR | SOIC | D | 8 | 2500 | 356.0 | 356.0 | 35.0 |
| ISO1541DR | SOIC | D | 8 | 2500 | 356.0 | 356.0 | 35.0 |

TUBE

*All dimensions are nominal

| Device | Package Name | Package Type | Pins | SPQ | L (mm) | W (mm) | T (μm) | B (mm) |
|----------|--------------|--------------|------|-----|--------|--------|--------|--------|
| ISO1540D | D | SOIC | 8 | 75 | 505.46 | 6.76 | 3810 | 4 |
| ISO1541D | D | SOIC | 8 | 75 | 505.46 | 6.76 | 3810 | 4 |



D0008A

PACKAGE OUTLINE

SOIC - 1.75 mm max height

SMALL OUTLINE INTEGRATED CIRCUIT



4214825/C 02/2019

NOTES:

- Linear dimensions are in inches [millimeters]. Dimensions in parenthesis are for reference only. Controlling dimensions are in inches. Dimensioning and tolerancing per ASME Y14.5M.
- This drawing is subject to change without notice.
- This dimension does not include mold flash, protrusions, or gate burrs. Mold flash, protrusions, or gate burrs shall not exceed .006 [0.15] per side.
- This dimension does not include interlead flash.
- Reference JEDEC registration MS-012, variation AA.

EXAMPLE BOARD LAYOUT

D0008A

SOIC - 1.75 mm max height

SMALL OUTLINE INTEGRATED CIRCUIT



LAND PATTERN EXAMPLE
EXPOSED METAL SHOWN
SCALE:8X



SOLDER MASK DETAILS

4214825/C 02/2019

NOTES: (continued)

6. Publication IPC-7351 may have alternate designs.

7. Solder mask tolerances between and around signal pads can vary based on board fabrication site.

EXAMPLE STENCIL DESIGN

D0008A

SOIC - 1.75 mm max height

SMALL OUTLINE INTEGRATED CIRCUIT



SOLDER PASTE EXAMPLE
BASED ON .005 INCH [0.125 MM] THICK STENCIL
SCALE:8X

4214825/C 02/2019

NOTES: (continued)

8. Laser cutting apertures with trapezoidal walls and rounded corners may offer better paste release. IPC-7525 may have alternate design recommendations.
9. Board assembly site may have different recommendations for stencil design.

IMPORTANT NOTICE AND DISCLAIMER

TI PROVIDES TECHNICAL AND RELIABILITY DATA (INCLUDING DATA SHEETS), DESIGN RESOURCES (INCLUDING REFERENCE DESIGNS), APPLICATION OR OTHER DESIGN ADVICE, WEB TOOLS, SAFETY INFORMATION, AND OTHER RESOURCES "AS IS" AND WITH ALL FAULTS, AND DISCLAIMS ALL WARRANTIES, EXPRESS AND IMPLIED, INCLUDING WITHOUT LIMITATION ANY IMPLIED WARRANTIES OF MERCHANTABILITY, FITNESS FOR A PARTICULAR PURPOSE OR NON-INFRINGEMENT OF THIRD PARTY INTELLECTUAL PROPERTY RIGHTS.

These resources are intended for skilled developers designing with TI products. You are solely responsible for (1) selecting the appropriate TI products for your application, (2) designing, validating and testing your application, and (3) ensuring your application meets applicable standards, and any other safety, security, regulatory or other requirements.

These resources are subject to change without notice. TI grants you permission to use these resources only for development of an application that uses the TI products described in the resource. Other reproduction and display of these resources is prohibited. No license is granted to any other TI intellectual property right or to any third party intellectual property right. TI disclaims responsibility for, and you will fully indemnify TI and its representatives against, any claims, damages, costs, losses, and liabilities arising out of your use of these resources.

TI's products are provided subject to [TI's Terms of Sale](#) or other applicable terms available either on [ti.com](https://www.ti.com) or provided in conjunction with such TI products. TI's provision of these resources does not expand or otherwise alter TI's applicable warranties or warranty disclaimers for TI products.

TI objects to and rejects any additional or different terms you may have proposed.

Mailing Address: Texas Instruments, Post Office Box 655303, Dallas, Texas 75265
Copyright © 2024, Texas Instruments Incorporated

Looking for pricing, stock, or lifecycle information?

Click below to explore more details on WIN SOURCE:

 [View ISO1541DR](#) on WIN SOURCE

 [Texas Instruments](#) Information

Optimize Your Supply Chain with WIN SOURCE Solutions

-  Global Sourcing Solution
-  Obsolete Management
-  Cost Control Management
-  Shortage Management
-  Alternative Solution
-  Excess Inventory Management