



**NOT RECOMMENDED FOR NEW DESIGNS**  
**RECOMMENDED REPLACEMENT PART**  
**ISL98603**

## ISL97653A

### 5-Channel Integrated LCD Supply

FN6367  
 Rev 3.00  
 September 7, 2010

The ISL97653A represents a fully integrated supply IC for LCD-TV applications. With an input operating range of 4V to 14V, both commonly used LCD-TV input supplies, 5V and 12V, are supported. An  $A_{VDD}$  supply up to 20V is generated by a high-performance PWM BOOST converter with an integrated 4.4A FET.  $V_{ON}$  is generated using an integrated charge pump with on-chip diodes and can be modulated using an on-chip  $V_{ON}$  slice control circuit.  $V_{OFF}$  is generated using an integrated charge pump controller. Additionally, the chip allows for two logic supplies. A buck regulator with an included 2.5A high side switch is used for the main logic output and an internal LDO controller can be used to generate a second logic LDO output.

To facilitate production test, an integrated HVS circuit is included which can provide high voltage stress of the LCD panel.

An on-board temperature sensor is also provided for system thermal management control.

The ISL97653A is packaged in a 40 Ld 6mmx6mm QFN package and is specified for operation over the  $-40^{\circ}\text{C}$  to  $+105^{\circ}\text{C}$  temperature range.

### Ordering Information

| PART NUMBER<br>(Note) | PART MARKING | PACKAGE<br>(Pb-Free)             | PKG. DWG. # |
|-----------------------|--------------|----------------------------------|-------------|
| ISL97653AIRZ          | 97653A IRZ   | 40 Ld 6X6 QFN                    | L40.6X6     |
| ISL97653AIRZ-T*       | 97653A IRZ   | 40 Ld 6X6 QFN<br>(Tape and Reel) | L40.6X6     |
| ISL97653AIRZ-TK*      | 97653A IRZ   | 40 Ld 6X6 QFN<br>(Tape and Reel) | L40.6X6     |

\*Please refer to TB347 for details on reel specifications.

NOTE: These Intersil Pb-free plastic packaged products employ special Pb-free material sets, molding compounds/die attach materials, and 100% matte tin plate plus anneal (e3 termination finish, which is RoHS compliant and compatible with both SnPb and Pb-free soldering operations). Intersil Pb-free products are MSL classified at Pb-free peak reflow temperatures that meet or exceed the Pb-free requirements of IPC/JEDEC J STD-020.

### Features

- 5V to 14V Input Supply
- Integrated 4.4A Boost Converter
- Integrated  $V_{ON}$  Charge Pump and  $V_{ON}$  Slice Circuit
- Integrated  $V_{OFF}$  Charge Pump Output
- Integrated 2.5A Buck Converter
- LDO Controller for an Additional Logic Supply
- High Voltage Stress (HVS) Test Mode
- Thermal Shutdown
- 40 Ld QFN (6mmx6mm) Package
- Pb-Free (RoHS Compliant)

### Applications

- LCD-TVs
- Industrial/Medical LCD Displays

### Pinout

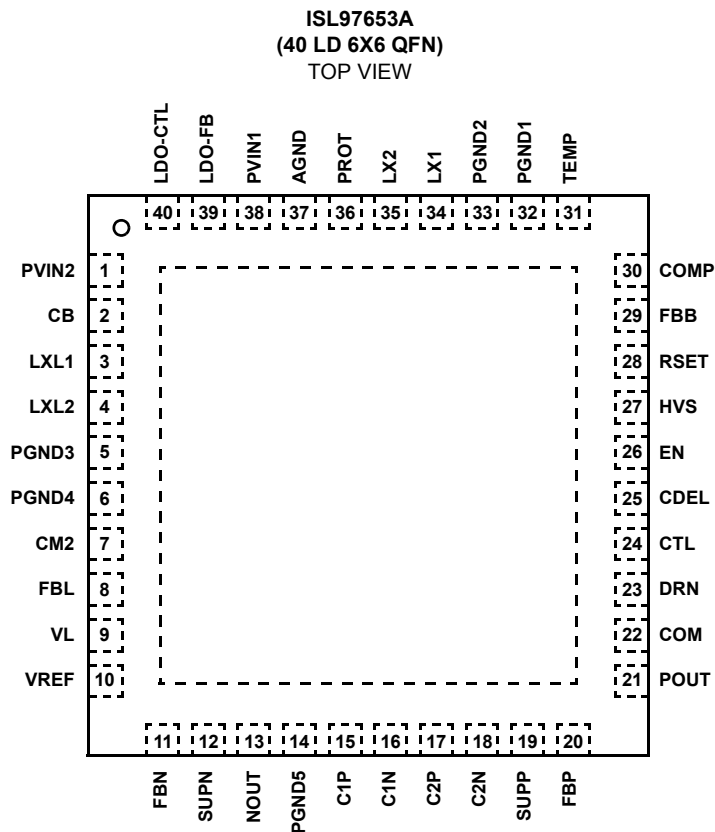

**Absolute Maximum Ratings** ( $T_A = +25^\circ\text{C}$ )

|                                             |       |
|---------------------------------------------|-------|
| Maximum Pin Voltages, All Pins Except Below | 6.5V  |
| LX1, LX2, SUPP, SUPN, NOUT, PROT, C1N, C2N  | .24V  |
| PVIN1, PVIN2, LXL1, LXL2                    | 16.8V |
| EN, CTL                                     | 16.5V |
| DRN, POUT, COM, C1P, C2P                    | .33V  |
| CB                                          | .21V  |

**Thermal Information**

|                                     |                                                                                                                 |                                             |
|-------------------------------------|-----------------------------------------------------------------------------------------------------------------|---------------------------------------------|
| Thermal Resistance                  | $\theta_{JA}$ ( $^\circ\text{C}/\text{W}$ )                                                                     | $\theta_{JC}$ ( $^\circ\text{C}/\text{W}$ ) |
| 6x6 QFN Package (Notes 1, 2)        | 29                                                                                                              | 1                                           |
| Operating Ambient Temperature Range | -40 $^\circ\text{C}$ to +105 $^\circ\text{C}$                                                                   |                                             |
| Operating Junction Temperature      | -40 $^\circ\text{C}$ to +150 $^\circ\text{C}$                                                                   |                                             |
| Pb-Free Reflow Profile              | see link below                                                                                                  |                                             |
|                                     | <a href="http://www.intersil.com/pbfree/Pb-FreeReflow.asp">http://www.intersil.com/pbfree/Pb-FreeReflow.asp</a> |                                             |

**Recommended Operating Conditions**

|                                         |                                       |
|-----------------------------------------|---------------------------------------|
| Input Voltage Range, $V_{IN}$           | 4V to 14V                             |
| Input Capacitance, $C_{IN}$             | .2x10 $\mu\text{F}$                   |
| Boost Output Voltage Range, $A_{VDD}$   | +20V                                  |
| Output Capacitance, $C_{OUT}$           | .3x22 $\mu\text{F}$                   |
| Boost Inductor, L1                      | 3.3 $\mu\text{H}$ -10 $\mu\text{H}$   |
| $V_{ON}$ Output Range, $V_{ON}$         | +15V to +30V                          |
| $V_{OFF}$ Output Range, $V_{OFF}$       | -15V to -5V                           |
| Logic Output Voltage Range, $V_{LOGIC}$ | +1.5V to +3.3V                        |
| Buck Inductor, L2                       | 3.3 $\mu\text{H}$ to 10 $\mu\text{H}$ |

**CAUTION:** Do not operate at or near the maximum ratings listed for extended periods of time. Exposure to such conditions may adversely impact product reliability and result in failures not covered by warranty.

## NOTES:

- $\theta_{JA}$  is measured in free air with the component mounted on a high effective thermal conductivity test board with "direct attach" features. See Tech Brief TB379.
- For  $\theta_{JC}$ , the "case temp" location is the center of the exposed metal pad on the package underside.

**Electrical Specifications**  $V_{IN} = 12\text{V}$ ,  $V_{BOOST} = V_{SUPN} = V_{SUPP} = 15\text{V}$ ,  $V_{ON} = 25\text{V}$ ,  $V_{OFF} = -8\text{V}$ , over-temperature from -40 $^\circ\text{C}$  to +105 $^\circ\text{C}$ , unless otherwise stated.

| PARAMETER                          | DESCRIPTION                    | CONDITIONS                           | MIN<br>(Note 3) | TYP   | MAX<br>(Note 3) | UNIT             |
|------------------------------------|--------------------------------|--------------------------------------|-----------------|-------|-----------------|------------------|
| <b>SUPPLY PINS</b>                 |                                |                                      |                 |       |                 |                  |
| $V_{IN}$                           | Supply Voltage                 |                                      | 4               |       | 14              | V                |
| $I_S$                              | Quiescent Current              | Enabled, no switching                |                 | 4     | 5               | mA               |
|                                    |                                | Disabled                             |                 | 2.7   | 3.5             | mA               |
| $F_{SW}$                           | Switching Frequency            |                                      | 580             | 680   | 780             | kHz              |
| $V_{REF}$                          | Reference Voltage              | $T_A = +25^\circ\text{C}$            | 1.190           | 1.215 | 1.240           | V                |
|                                    |                                |                                      | 1.187           | 1.215 | 1.243           | V                |
| $V_{LOR}$                          | Undervoltage Lockout Threshold | $V_L$ rising                         | 3.4             | 3.55  | 3.7             | V                |
| $V_{LOF}$                          | Undervoltage Lockout Threshold | $V_L$ falling                        | 2.9             | 3.0   | 3.2             | V                |
|                                    | Thermal Shutdown               | Temperature rising                   |                 | 150   |                 | $^\circ\text{C}$ |
|                                    | Thermal Shutdown Hysteresis    |                                      |                 | 20    |                 | $^\circ\text{C}$ |
| <b>LOGIC SIGNALS HV_S, EN, CTL</b> |                                |                                      |                 |       |                 |                  |
| Logic Input High                   |                                |                                      | 2.0             |       |                 | V                |
| Logic Input Low                    |                                |                                      |                 |       | 0.4             | V                |
| Pull-down Resistance               |                                |                                      | 115             | 174   | 250             | k $\Omega$       |
| <b>HV_S, RSET</b>                  |                                |                                      |                 |       |                 |                  |
| RSET                               | RSET Pull-down Resistance      | HV_S = HIGH                          |                 | 200   |                 | $\Omega$         |
| $I_{RSET}$                         | RSET Leakage Current           | HV_S = LOW, $V_{RSET} = 1.2\text{V}$ |                 |       | 0.4             | $\mu\text{A}$    |
| <b><math>A_{VDD}</math> BOOST</b>  |                                |                                      |                 |       |                 |                  |
| DLIM                               | Min Duty Cycle                 |                                      |                 | 8.5   | 12              | %                |
|                                    | Max Duty Cycle                 |                                      |                 | 90    |                 | %                |

**Electrical Specifications**  $V_{IN} = 12V$ ,  $V_{BOOST} = V_{SUPN} = V_{SUPP} = 15V$ ,  $V_{ON} = 25V$ ,  $V_{OFF} = -8V$ , over-temperature from  $-40^{\circ}C$  to  $+105^{\circ}C$ , unless otherwise stated. **(Continued)**

| PARAMETER                               | DESCRIPTION                                   | CONDITIONS                                         | MIN<br>(Note 3) | TYP   | MAX<br>(Note 3) | UNIT      |
|-----------------------------------------|-----------------------------------------------|----------------------------------------------------|-----------------|-------|-----------------|-----------|
| $V_{BOOST}$                             | Boost Output Range                            |                                                    |                 | 20    |                 | V         |
| $EFF_{BOOST}$                           | Boost Efficiency                              | $V_{IN} = 12V$ , $V_{BOOST} = 15V$                 |                 | 90+   |                 | %         |
| $V_{FB}$                                | Boost Feedback Voltage                        | $T_A = +25^{\circ}C$                               | 1.203           | 1.215 | 1.227           | V         |
|                                         |                                               |                                                    | 1.198           | 1.215 | 1.232           | V         |
| $I_{BOOST}$                             | Boost FET Current Limit                       |                                                    | 3.7             | 4.4   | 5.1             | A         |
| $r_{DS(ON)-BOOST}$                      | Switch ON-Resistance                          |                                                    |                 | 93    | 200             | $m\Omega$ |
| $\Delta V_{BOOST}/\Delta V_{IN}$        | Line Regulation - Boost                       |                                                    |                 | 0.08  | 0.15            | %         |
| $\Delta V_{BOOST}/\Delta I_{OUT}$       | Load Regulation - Boost                       | Load 100mA to 200mA                                |                 | 0.004 | 1               | %         |
| <b>LOGIC BUCK</b>                       |                                               |                                                    |                 |       |                 |           |
| $EFF_{BUCK}$                            | Buck Efficiency                               | $V_{IN} = 5V$ , $V_{LOGIC} = 3.3V$                 |                 | 90+   |                 | %         |
| $I_{BUCK}$                              | Buck FET Current Limit                        |                                                    | 2.6             |       | 4.7             | A         |
| $r_{DS(ON)-BUCK}$                       | Switch On Resistance                          |                                                    |                 | 150   | 210             | $m\Omega$ |
| $\Delta V_{LDO}/\Delta I_{OUT}$         | Load Regulation - Buck                        | Load 100mA to 500mA                                |                 | 0.5   | 1               | %         |
| $V_{FL}$                                | Feedback Voltage                              | $T_A = +25^{\circ}C$                               | 1.195           | 1.215 | 1.235           | V         |
|                                         |                                               |                                                    | 1.189           | 1.215 | 1.241           | V         |
| <b><math>V_{ON}</math> CHARGE PUMP</b>  |                                               |                                                    |                 |       |                 |           |
| $I_{Load\_PCP\_min}$                    | External Load Driving Capability              | $V_{ON} = 24V$ (2X Charge Pump)                    | 40              |       |                 | mA        |
|                                         |                                               | $V_{ON} = 28V$ (3X Charge Pump)                    | 40              |       |                 | mA        |
| $V_{FBP}$                               | Feedback Voltage, $I_{ON} = 1mA$              | $T_A = +25^{\circ}C$                               | 1.195           | 1.215 | 1.235           | V         |
|                                         |                                               |                                                    | 1.189           | 1.215 | 1.241           | V         |
| $r_{ON} (VSUP\_SW)$                     | ON Resistance of $V_{SUP}$ Input Switch       | $I(\text{switch}) = +40mA$                         |                 | 10    | 17              | $\Omega$  |
| $r_{ON} (C1/2-)H$                       | High-Side Driver ON-Resistance at C1- and C2- | $I(C1/2-) = +40mA$                                 |                 |       | 30              | $\Omega$  |
| $r_{ON} (C1/2-)L$                       | Low-Side Driver ON-Resistance at C1- and C2-  | $I(C1/2-) = -40mA$                                 |                 | 4     | 10              | $\Omega$  |
| $V_{ON}$ Load Reg                       | $V_{ON}$ Output Load Regulation               | $I_{ON} = 10mA$ to $40mA$                          |                 | 0.3   |                 | %         |
| $V(\text{diode})$                       | Internal Schottky Diode Forward Voltage Drop  | $I(\text{diode}) = +40mA$                          |                 | 700   | 800             | mV        |
| <b><math>V_{OFF}</math> CHARGE PUMP</b> |                                               |                                                    |                 |       |                 |           |
| $I_{Load\_NCP\_min}$                    | External Load Driving Capability              | $SUPN > 13.5V$ $V_{OFF} = -8V$                     | 100             | 120   |                 | mA        |
| $V_{FBN}$                               | Feedback Voltage, $I_{OFF} = 10mA$            | $T_A = +25^{\circ}C$                               | 0.173           | 0.203 | 0.233           | V         |
|                                         |                                               |                                                    | 0.171           | 0.203 | 0.235           | V         |
| $r_{ON} (NOUT)H$                        | High-Side Driver ON-Resistance at NOUT        | $I(NOUT) = +60mA$                                  |                 |       | 10              | $\Omega$  |
| $r_{ON} (NOUT)L$                        | Low-Side Driver ON-Resistance at NOUT         | $I(NOUT) = -60mA$                                  |                 |       | 5               | $\Omega$  |
| $V_{OFF}$ Load Reg                      | $V_{OFF}$ Output Load Reg                     | $I_{OFF} = 10mA$ to $100mA$ , $T_A = +25^{\circ}C$ |                 |       | 2.4             | %         |
| <b>LDO Controller</b>                   |                                               |                                                    |                 |       |                 |           |
| $I_{DRVP}$                              | Sink Current                                  | $V_{FBP} = 1.1V$ , $V_{LDO\_CTL} = 10V$            | 12              | 15    |                 | mA        |

**Electrical Specifications**  $V_{IN} = 12V, V_{BOOST} = V_{SUPN} = V_{SUPP} = 15V, V_{ON} = 25V, V_{OFF} = -8V$ , over-temperature from  $-40^{\circ}C$  to  $+105^{\circ}C$ , unless otherwise stated. **(Continued)**

| PARAMETER                                                               | DESCRIPTION                                                      | CONDITIONS                    | MIN<br>(Note 3) | TYP   | MAX<br>(Note 3) | UNIT        |
|-------------------------------------------------------------------------|------------------------------------------------------------------|-------------------------------|-----------------|-------|-----------------|-------------|
| LDO-FB                                                                  | Feedback Voltage w/transistor load 1mA                           | $T_A = +25^{\circ}C$          | 1.191           | 1.215 | 1.239           | V           |
|                                                                         |                                                                  |                               | 1.189           | 1.215 | 1.241           | V           |
| <b>FAULT DETECTION THRESHOLDS</b>                                       |                                                                  |                               |                 |       |                 |             |
| $T_{off}$                                                               | Thermal Shut-Down (latched and reset by power cycle or EN cycle) | Temperature rising            |                 | 150   |                 | $^{\circ}C$ |
| $V_{th\_A_{VDD}}(FBB)$                                                  | $A_{VDD}$ Boost Short Detection                                  | $V(FBB)$ falling less than    |                 | 0.9   |                 | V           |
| $V_{th\_POUT}(FBP)$                                                     | $P_{OUT}$ Charge Pump Short Detection                            | $V(FBP)$ falling less than    |                 | 0.9   |                 | V           |
| $V_{th\_NOUT}(FBN)$                                                     | $N_{OUT}$ Charge Pump Short Detection                            | $V(FBN)$ rising more than     |                 | 0.4   |                 | V           |
| <b><math>V_{ON}</math> Slice POSITIVE SUPPLY = <math>V(POUT)</math></b> |                                                                  |                               |                 |       |                 |             |
| $I(POUT)_{slice}$                                                       | $V_{ON}$ Slice Current from POUT Supply                          | CTL = VDD, sequence complete  |                 | 400   | 500             | $\mu A$     |
|                                                                         |                                                                  | CTL = AGND, sequence complete |                 | 150   | 200             | $\mu A$     |
| $r_{ON}(POUT-COM)$                                                      | ON-Resistance between POUT-COM                                   | CTL = VDD, sequence complete  |                 | 5     | 10              | $\Omega$    |
| $r_{ON}(DRN-COM)$                                                       | ON-Resistance between DRN-COM                                    | CTL = AGND, sequence complete |                 | 30    | 60              | $\Omega$    |
| $r_{ON\_COM}$                                                           | ON-Resistance between DRN-COM and PGND                           |                               | 200             | 260   | 400             | $\Omega$    |
| <b>PROT</b>                                                             |                                                                  |                               |                 |       |                 |             |
| $I_{PROT\_ON}$                                                          | PROT Pull-Down Current or Resistance when Enabled by the Start-U | $V_{PROT} > 0.9V$             | 38              | 50    | 60              | $\mu A$     |
|                                                                         |                                                                  | $V_{PROT} < 0.9V$             | 500             | 760   | 1000            | $\Omega$    |
| $I_{PROT\_OFF}$                                                         | PROT Pull-Up Current when Disabled                               | $V_{PROT} < 20V$              | 2               | 3     | 4.5             | mA          |

## NOTE:

3. Parameters with MIN and/or MAX limits are 100% tested at  $+25^{\circ}C$ , unless otherwise specified. Temperature limits established by characterization and are not production tested.

Typical Application Diagram

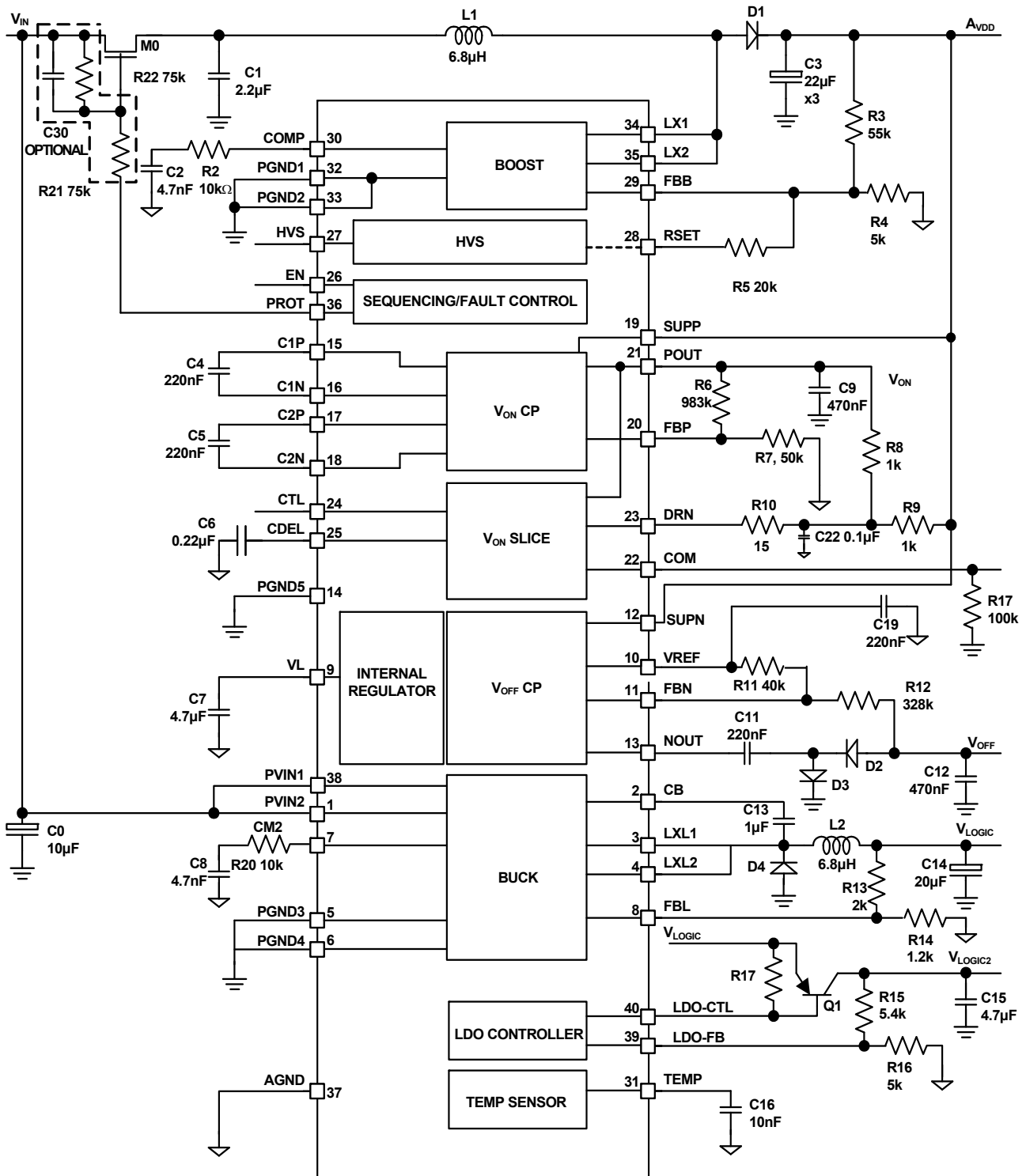

Typical Application Diagram (Continued)

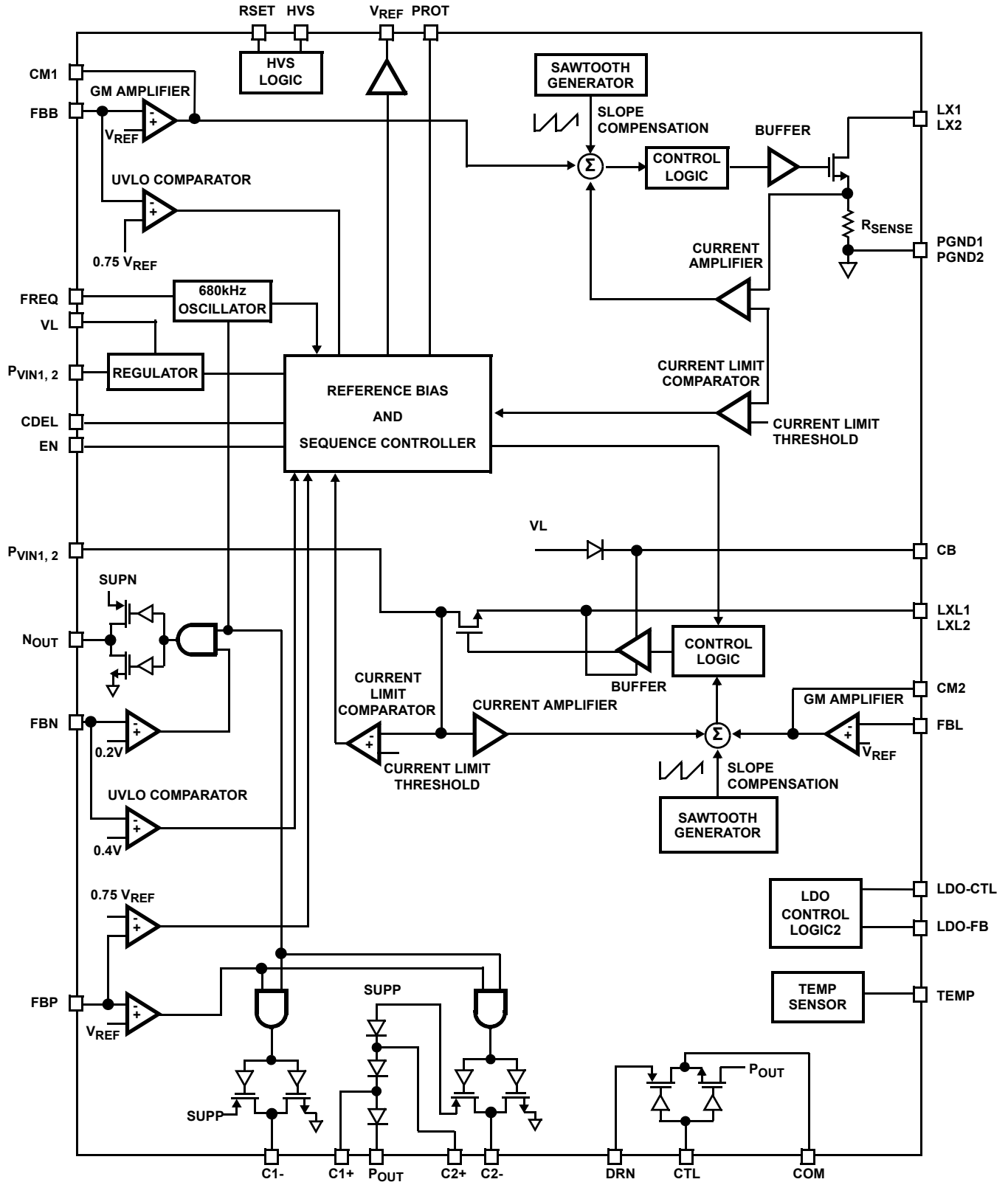

Typical Performance Curves

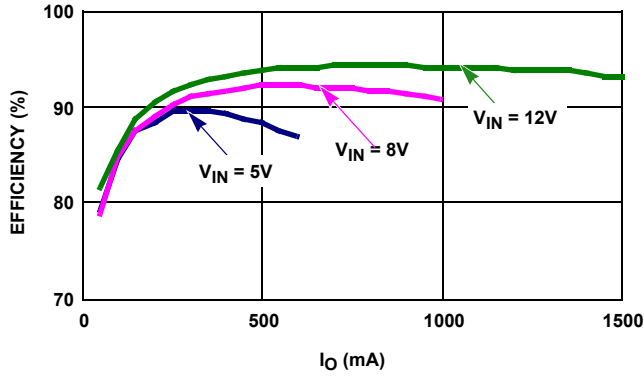

FIGURE 1. BOOST EFFICIENCY

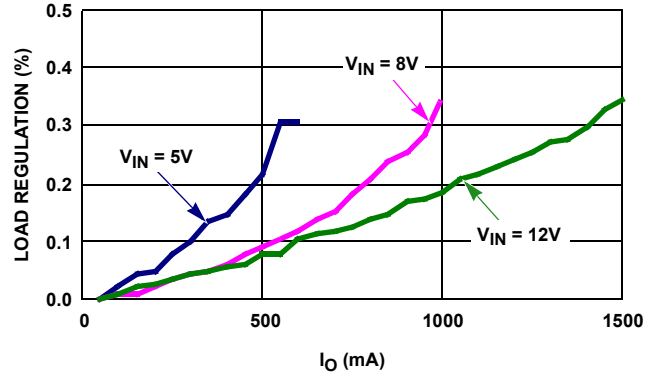

FIGURE 2. BOOST LOAD REGULATION

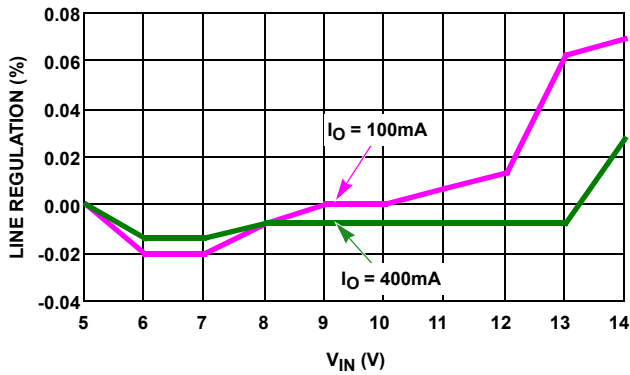

FIGURE 3. BOOST LINE REGULATION

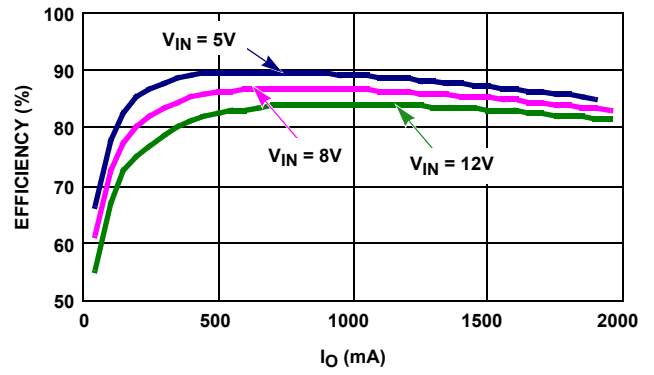

FIGURE 4. BUCK EFFICIENCY

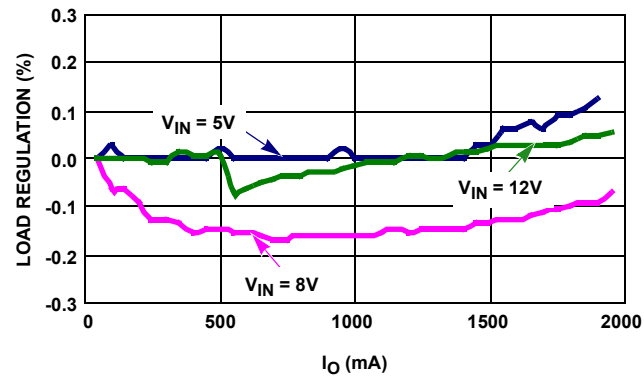

FIGURE 5. BUCK LOAD REGULATION

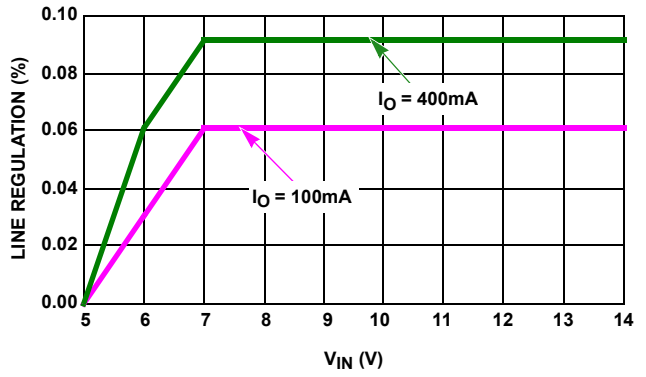

FIGURE 6. BUCK LINE REGULATION

Typical Performance Curves (Continued)

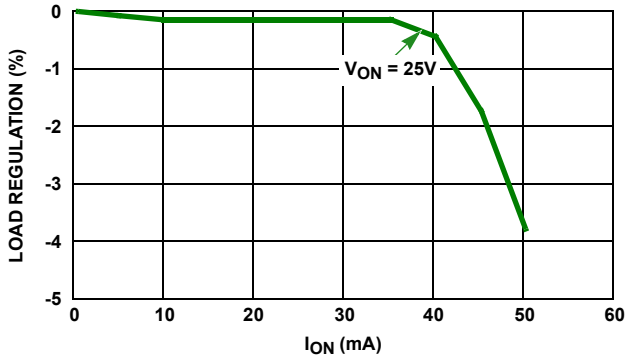

FIGURE 7.  $V_{ON}$  LOAD REGULATION

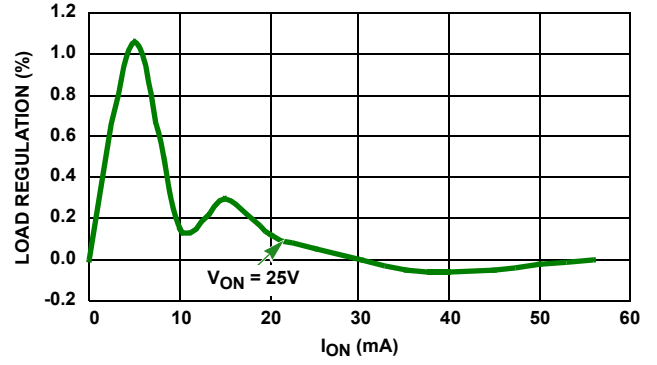

FIGURE 8.  $V_{OFF}$  LOAD REGULATION

CH1 =  $A_{VDD}(V_{BOOST})(500mV/DIV)$   
 CH2 =  $I_O(BOOST)(200mA/DIV)$

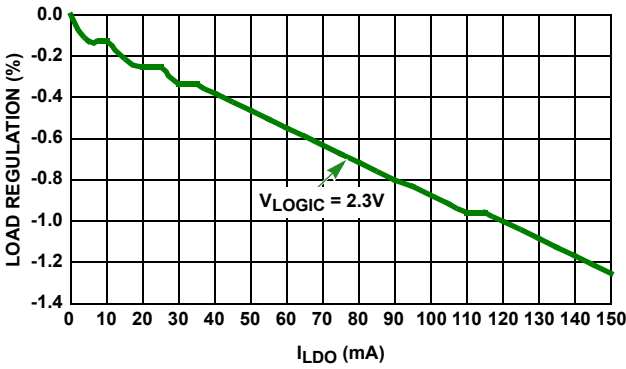

FIGURE 9. LOGIC LDO LOAD REGULATION

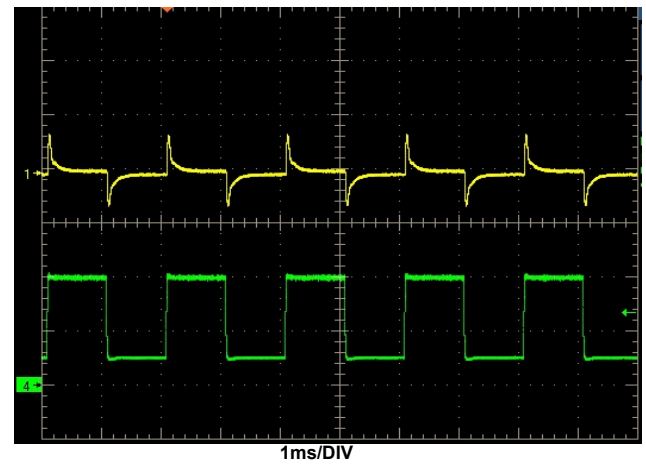

FIGURE 10. BOOST TRANSIENT RESPONSE

CH1 =  $A_{VDD}(V_{BOOST})(100mV/DIV)$   
 CH2 =  $I_O(BOOST)(100mA/DIV)$

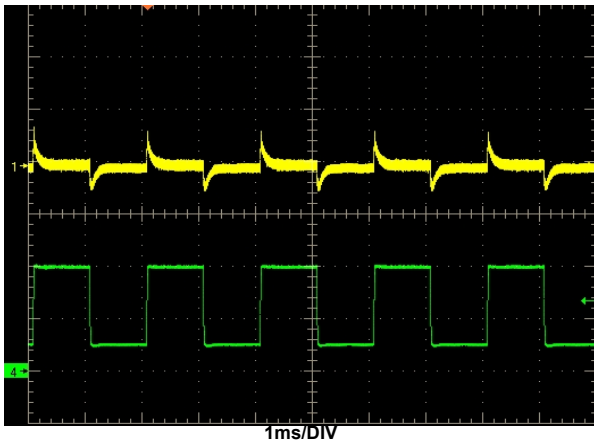

FIGURE 11. BUCK TRANSIENT RESPONSE

CH1 =  $V_{CTL}(5V/DIV)$   
 CH2 =  $COM(10V/DIV)$

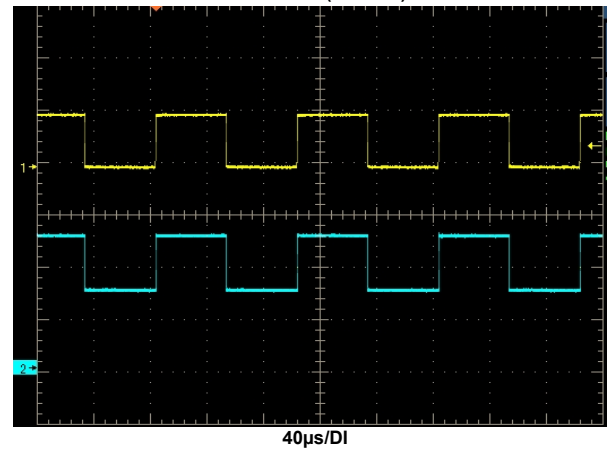

FIGURE 12.  $V_{ON}$  SLICE OPERATION

## Typical Performance Curves (Continued)

Ch1 = LXL (400ns/DIV)  
Ch2 = ILXL (400ns/DIV)

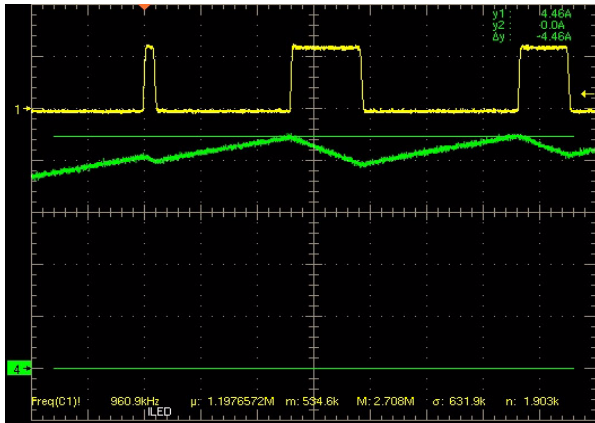

FIGURE 13. BOOST CURRENT LIMIT

Ch1 = LXL (400ns/DIV)  
Ch2 = ILXL (400ns/DIV)

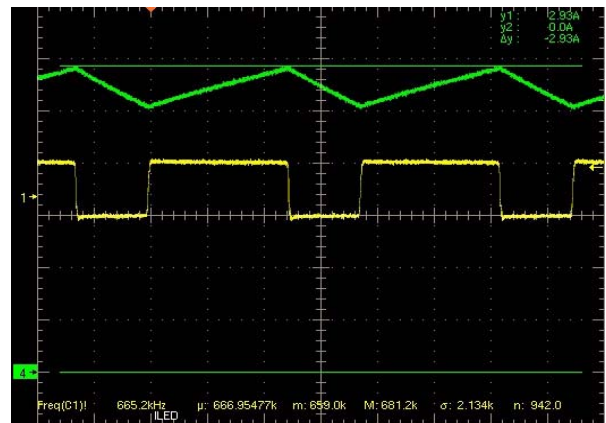

FIGURE 14. BUCK CURRENT LIMIT

## Pin Descriptions

| PIN NUMBER | PIN NAME     | DESCRIPTION                                                                                                                                                                           |
|------------|--------------|---------------------------------------------------------------------------------------------------------------------------------------------------------------------------------------|
| 1          | PVIN2        | Logic buck supply voltage. This is also the analog supply from which the VL is generated. Needs at least 1 $\mu$ F bypassing.                                                         |
| 2          | CB           | Logic buck boot strap pin. Generate the gate drive voltage for the N-Channel MOSFET by connecting a 1 $\mu$ F cap to the switching node LXL1, 2.                                      |
| 3, 4       | LXL1, LXL2   | Logic buck switching node. Source of the high side internal power N-Channel MOSFET for the Buck.                                                                                      |
| 5, 6       | PGND3, PGND4 | Logic buck ground pin.                                                                                                                                                                |
| 7          | CM2          | Buck compensation pin. An RC network is recommended. Increase R for better transient response at the expense of stability.                                                            |
| 8          | FBL          | Logic buck feedback pin. High impedance input to regulate at 1.215V.                                                                                                                  |
| 9          | VL           | 5.25V internal regulator output. Bypass with a 4.7 $\mu$ F capacitor. Ref voltage is generated from VL.                                                                               |
| 10         | VREF         | Reference voltage output. Bypass with a low valued capacitor for transients - recommend 220nF. Should not be greater than 5 times CDEL capacitor to ensure correct start-up sequence. |
| 11         | FBN          | Negative charge pump feedback pin. High impedance input to regulate to 0.203V.                                                                                                        |
| 12         | SUPN         | Negative charge pump supply voltage. Can be the same as or different from $A_{VDD}$ .                                                                                                 |
| 13         | NOUT         | Negative charge pump driver output.                                                                                                                                                   |
| 14         | PGND5        | Charge pump ground pin.                                                                                                                                                               |
| 15         | C1P          | Charge pump capacitor 1, positive connection.                                                                                                                                         |
| 16         | C1N          | Charge pump capacitor 1, negative connection.                                                                                                                                         |
| 17         | C2P          | Charge pump capacitor 2, positive connection.                                                                                                                                         |
| 18         | C2N          | Charge pump capacitor 2, negative connection.                                                                                                                                         |
| 19         | SUPP         | Positive charge pump supply. Can be the same as or different from $A_{VDD}$ .                                                                                                         |
| 20         | FBP          | Positive charge pump feedback pin. High impedance input to regulate at 1.215V                                                                                                         |
| 21         | POUT         | $V_{ON}$ charge pump output.                                                                                                                                                          |
| 22         | COM          | High voltage switch control output. $V_{ON}$ slice output.                                                                                                                            |
| 23         | DRN          | Lower reference voltage for $V_{ON}$ slice output. Usually connected to $A_{VDD}$ .                                                                                                   |
| 24         | CTL          | Input control pin for $V_{ON}$ slice output.                                                                                                                                          |

**Pin Descriptions** (Continued)

| PIN NUMBER | PIN NAME     | DESCRIPTION                                                                                                                                                                                                                                        |
|------------|--------------|----------------------------------------------------------------------------------------------------------------------------------------------------------------------------------------------------------------------------------------------------|
| 25         | CDEL         | $V_{ON}$ slice control delay input. Minimum 47nF. Recommend 220nF but is only limited by leakage in the cap reaching $\mu A$ levels.                                                                                                               |
| 26         | EN           | Chip enable (active high). Can be driven to VIN levels.                                                                                                                                                                                            |
| 27         | HVS          | High-voltage stress input select pin. High selects high voltage mode.                                                                                                                                                                              |
| 28         | RSET         | Voltage set pin for HVS test. RSET connects to ground in the high voltage mode - RSET high.                                                                                                                                                        |
| 29         | FBB          | $A_{VDD}$ boost feedback pin. High impedance input to regulate at 1.215V.                                                                                                                                                                          |
| 30         | COMP         | Boost compensation network pin. An RC network is recommended. Increase R for better transient response at the expense of stability. R = 0 $\Omega$ is recommended for 4.4A Boost requirements.                                                     |
| 31         | TEMP         | Temperature sensor output voltage. An analog voltage from 0V to 3V for temperatures of -40°C to +150°C.                                                                                                                                            |
| 32, 33     | PGND1, PGND2 | Boost ground pins.                                                                                                                                                                                                                                 |
| 34, 35     | LX1, LX2     | Boost switch output. Drain of the internal power NMOS for the Boost.                                                                                                                                                                               |
| 36         | PROT         | Gate driver of the Input protection switch. Goes low when EN is high. Can be used to modulate the passive input inrush current as shown by R <sub>21</sub> , R <sub>22</sub> , and C <sub>30</sub> in the "Typical Application Diagram" on page 5. |
| 37         | AGND         | Analog ground. Separate from PGND's and star under the chip.                                                                                                                                                                                       |
| 38         | PVIN1        | Logic buck supply voltage. This is also the analog supply from which the VL is generated. Needs at least 1 $\mu F$ bypassing.                                                                                                                      |
| 39         | LDO-FB       | LDO controller feedback. High impedance input to regulate at 1.215V.                                                                                                                                                                               |
| 40         | LDO-CTL      | LDO control pin. Gate drive for the external PNP BJT.                                                                                                                                                                                              |

## Application Information

### *A<sub>VDD</sub>* Boost Converter

The *A<sub>VDD</sub>* boost converter features a fully integrated 4.4A boost FET. The regulator uses a current mode PI control scheme which provides good line regulation and good transient response. It can operate in both discontinuous conduction mode (DCM) at light loads and continuous mode (CCM). In continuous current mode, current flows continuously in the inductor during the entire switching cycle in steady state operation. The voltage conversion ratio in continuous current mode is given by Equation 1:

$$\frac{V_{\text{boost}}}{V_{\text{IN}}} = \frac{1}{1-D} \quad (\text{EQ. 1})$$

where D is the duty cycle of the switching MOSFET.

The boost soft-start function is digitally controlled within a fixed 10ms time frame during which the current limit is increased in eight linear steps.

The boost converter uses a summing amplifier architecture for voltage feedback, current feedback, and slope compensation. A comparator looks at the peak inductor current cycle by cycle and terminates the PWM cycle if the current limit is triggered. Since this comparison is cycle based, the PWM output will be released after the peak current goes below the current limit threshold.

An external resistor divider is required to divide the output voltage down to the nominal reference voltage. Current drawn by the resistor network should be limited to maintain the overall converter efficiency. The maximum value of the resistor network is limited by the feedback input bias current and the potential for noise being coupled into the feedback pin. A resistor network in the order of 60kΩ is recommended. The boost converter output voltage is determined by Equation 2:

$$A_{\text{VDD}} = \frac{R_3 + R_4}{R_4} \times V_{\text{FBB}} \quad (\text{EQ. 2})$$

where *R<sub>3</sub>* and *R<sub>4</sub>* are in the “Typical Application Diagram” on page 5. Unless otherwise stated, component variables referred to in equations refer to the Typical Application Diagram.

The current through the MOSFET is limited to 4.4A peak. This restricts the maximum output current (average) based on Equation 3:

$$I_{\text{OMAX}} = \left( I_{\text{LMT}} - \frac{\Delta I_L}{2} \right) \times \frac{V_{\text{IN}}}{V_{\text{O}}} \quad (\text{EQ. 3})$$

Where  $\Delta I_L$  is peak to peak inductor ripple current, and is set by Equation 4. *f<sub>s</sub>* is the switching frequency (680kHz).

$$\Delta I_L = \frac{V_{\text{IN}}}{L} \times \frac{D}{f_s} \quad (\text{EQ. 4})$$

Table 1 gives typical values (worst case margins are considered 10%, 3%, 20%, 10% and 15% on *V<sub>IN</sub>*, *V<sub>O</sub>*, *L*, *F<sub>SW</sub>* and *I<sub>OMAX</sub>*):

**TABLE 1. MAXIMUM OUTPUT CURRENT CALCULATION**

| <i>V<sub>IN</sub></i> (V) | <i>V<sub>O</sub></i> (V) | <i>L</i> (μH) | <i>I<sub>OMAX</sub></i> (mA) |
|---------------------------|--------------------------|---------------|------------------------------|
| 5                         | 9                        | 6.8           | 2215                         |
| 5                         | 12                       | 6.8           | 1673                         |
| 5                         | 15                       | 6.8           | 1344                         |
| 12                        | 15                       | 6.8           | 3254                         |
| 12                        | 18                       | 6.8           | 2670                         |

### *Boost Converter Input Capacitor*

An input capacitor is used to suppress the voltage ripple injected into the boost converter. A ceramic capacitor with capacitance larger than 10μF is recommended. The voltage rating of input capacitor should be larger than the maximum input voltage. Some capacitors are recommended in Table 2 for input capacitor.

**TABLE 2. BOOST CONVERTER INPUT CAPACITOR RECOMMENDATION**

| CAPACITOR | SIZE | VENDOR | PART NUMBER    |
|-----------|------|--------|----------------|
| 10μF/25V  | 1210 | TDK    | C3225X7R1E106M |
| 10μF/25V  | 1210 | Murata | GRM32DR61E106K |

### *Boost Inductor*

The boost inductor is a critical part which influences the output voltage ripple, transient response, and efficiency. Values of 3.3μH to 10μH are recommended to match the internal slope compensation as well as to maintain a good transient response performance. The inductor must be able to handle the average and peak currents expressed in Equations 5 and 6:

$$I_{\text{LAVG}} = \frac{I_{\text{O}}}{1-D} \quad (\text{EQ. 5})$$

$$I_{\text{LPK}} = I_{\text{LAVG}} + \frac{\Delta I_L}{2} \quad (\text{EQ. 6})$$

Some inductors are recommended in Table 3.

**TABLE 3. BOOST INDUCTOR RECOMMENDATION**

| INDUCTOR                      | DIMENSIONS (mm) | VENDOR | PART NUMBER           |
|-------------------------------|-----------------|--------|-----------------------|
| 10μH/<br>5.1A <sub>PEAK</sub> | 13x13x4.5       | TDK    | RLF12545T-100M5R1     |
| 5.9μH/<br>6A <sub>PEAK</sub>  | 12.9X12.9X4     | Sumida | CDEP12D38NP-5R9MB-120 |

### Rectifier Diode (Boost Converter)

A high-speed diode is necessary due to the high switching frequency. Schottky diodes are recommended because of their fast recovery time and low forward voltage. The reverse voltage rating of this diode should be higher than the maximum output voltage. The rectifier diode must meet the output current and peak inductor current requirements. The following table lists two recommendations for boost converter diode.

**TABLE 4. BOOST CONVERTER RECTIFIER DIODE RECOMMENDATION**

| DIODE     | $V_R/I_{AVG}$ RATING | PACKAGE | VENDOR                  |
|-----------|----------------------|---------|-------------------------|
| FYD0504SA | 50V/2A               | DPAK    | Fairchild Semiconductor |
| 30WQ04FN  | 40V/3.5A             | DPAK    | International Rectifier |

### Output Capacitor

Integrating output capacitors supply the load directly and reduce the ripple voltage at the output. Output ripple voltage consists of two components: the voltage drop due to the inductor ripple current flowing through the ESR of output capacitor, and the charging and discharging of the output capacitor.

$$V_{RIPPLE} = I_{LPK} \times ESR + \frac{V_O - V_{IN}}{V_O} \times \frac{I_O}{C_{OUT}} \times \frac{1}{f_s} \quad (\text{EQ. 7})$$

For low ESR ceramic capacitors, the output ripple is dominated by the charging and discharging of the output capacitor. The voltage rating of the output capacitor should be greater than the maximum output voltage.

Note: Capacitors have a voltage coefficient that makes their effective capacitance drop as the voltage across them increases.  $C_{OUT}$  in Equation 7 assumes the effective value of the capacitor at a particular voltage and not the manufacturer's stated value, measured at zero volts.

Table 5 shows some selections of output capacitors.

**TABLE 5. BOOST OUTPUT CAPACITOR RECOMMENDATION**

| CAPACITOR      | SIZE | VENDOR | PART NUMBER    |
|----------------|------|--------|----------------|
| 10 $\mu$ F/25V | 1210 | TDK    | C3225X7R1E106M |
| 10 $\mu$ F/25V | 1210 | Murata | GRM32DR61E106K |

### PI Loop Compensation (Boost Converter)

The boost converter of ISL97653A can be compensated by a RC network connected from COMP pin to ground.  $C_2 = 4.7\text{nF}$  and  $R_2 = 0\Omega$  to  $10\Omega$ . A RC network is used in the demo board. A higher capacitor value can be used to increase system stability.

Stability can be examined by repeatedly changing the load between 100mA and a max level that is likely to be used in the

system being used. The  $A_{VDD}$  voltage should be examined with an oscilloscope set to AC 100mV/DIV and the amount of ringing observed when the load current changes. Reduce excessive ringing by reducing the value of the resistor in series with the CM1 pin capacitor.

### Cascaded MOSFET Application

A 20V N-Channel MOSFET is integrated in the boost regulator. For applications requiring output voltages greater than 20V, an external cascaded MOSFET is needed as shown in Figure 15. The voltage rating of the external MOSFET should be greater than  $A_{VDD}$ .

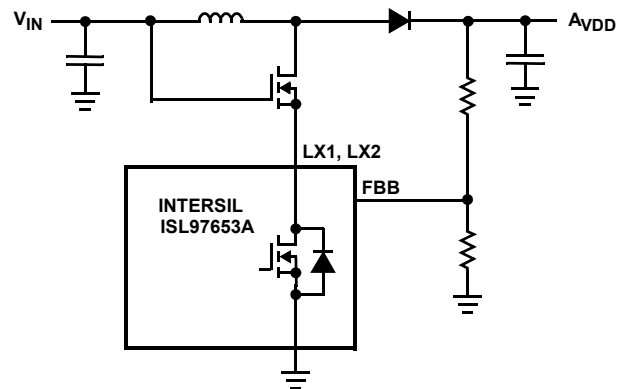

**FIGURE 15. CASCADED MOSFET TOPOLOGY FOR HIGH OUTPUT VOLTAGE APPLICATIONS**

### $V_{IN}$ Protection

A series external P-FET can be used to prevent passive power-up inrush current from the Boost output capacitors charging to  $V_{IN} - V_{SCHOTTKY}$  via the boost inductor and Schottky diode. This FET also adds protection in the event of a short circuit on  $A_{VDD}$ . The gate of the PFET (shown as M0 in the "Typical Application Diagram" on page 5) is controlled by PROT. When EN is low, PROT is pulled internally to  $PV_{IN1}$ , thus M0 is switched off. When EN goes high, PROT is pulled down slowly via a 50 $\mu$ A current source, switching M0 on.

If the device is powered up with EN tied to high, M0 will remain switched off until the voltage on VL exceeds the VLOR threshold. Once the voltage on PROT falls below 0.6V and the step-up regulator is within 90% of its target voltage, PROT is pulled down to ground via a 1.3k $\Omega$  impedance. If  $A_{VDD}$  falls 10% below regulation, the drive to PROT reverts to a 50 $\mu$ A current source. If a timed fault is detected, M0 is actively switched off.

Several additional external components can optionally be used to fine-tune the function of pin PROT (shown in the dashed box near M0 in the application diagram). PROT ramp rate can be controlled by adding a capacitor C30 between gate and source of M0. M0 gate voltage can be limited during soft-start by adding a resistor (~75k $\Omega$ ) between gate and source of M0. In addition, a resistor can be connected between PROT and the

gate of M0, in order to limit the maximum  $V_{GS}$  of M0 at all times.

### Buck Converter

The buck converter is a step down converter supplying power to the logic circuit of the LCD system. The ISL97653A integrates a high voltage N-channel MOSFET to save costs and reduce external component count. In the continuous current mode, the relationship between input voltage and output voltage as expressed in Equation 8:

$$\frac{V_{\text{LOGIC}}}{V_{\text{IN}}} = D \quad (\text{EQ. 8})$$

Where D is the duty cycle of the switching MOSFET. Because D is always less than 1, the output voltage of a buck converter is lower than input voltage.

The peak current limit of buck converter is set to 2.5A, which restricts the maximum output current (average) based on Equation 9:

$$I_{\text{OMAX}} = 2.5\text{A} - \Delta I_{\text{P-P}} \quad (\text{EQ. 9})$$

Where  $\Delta I_{\text{P-P}}$  is the ripple current in the buck inductor as shown in Equation 10:

$$\Delta I_{\text{PP}} = \frac{V_{\text{LOGIC}}}{L \cdot f_s} \cdot (1 - D) \quad (\text{EQ. 10})$$

Where L is the buck inductor,  $f_s$  is the switching frequency (680kHz).

### Feedback Resistors

The buck converter output voltage is determined by Equation 11:

$$V_{\text{LOGIC}} = \frac{R_{14} + R_{13}}{R_{14}} \times V_{\text{FBL}} \quad (\text{EQ. 11})$$

Where  $R_{13}$  and  $R_{14}$  are the feedback resistors in the buck converter loop to set the output voltage. Current drawn by the resistor network should be limited to maintain the overall converter efficiency. The maximum value of the resistor network is limited by the feedback input bias current and the potential for noise being coupled into the feedback pin. A resistor network in the order of 1k $\Omega$  is recommended.

### Buck Converter Input Capacitor

Input capacitance should support the maximum AC RMS current which occurs at  $D = 0.5$  and maximum output current.

$$I_{\text{acrms}}(C_{\text{IN}}) = \sqrt{D \cdot (1 - D)} \cdot I_{\text{O}} \quad (\text{EQ. 12})$$

Where  $I_{\text{O}}$  is the output current of the buck converter. Table 6 shows some recommendations for the input capacitor.

TABLE 6. INPUT CAPACITOR (BUCK) RECOMMENDATION

| CAPACITOR      | SIZE | VENDOR | PART NUMBER    |
|----------------|------|--------|----------------|
| 10 $\mu$ F/16V | 1206 | TDK    | C3216X7R1C106M |
| 10 $\mu$ F/10V | 0805 | Murata | GRM21BR61A106K |
| 22 $\mu$ F/16V | 1210 | Murata | C3225X7R1C226M |

### Buck Inductor

A 3.3 $\mu$ H to 10 $\mu$ H inductor range is recommended for the buck converter. Besides the inductance, the DC resistance and the saturation current are also factors that need to be considered when choosing a buck inductor. Low DC resistance can help maintain high efficiency. Saturation current rating should be higher than 2A. Here are some recommendations for the buck inductor.

TABLE 7. BUCK INDUCTOR RECOMMENDATION

| INDUCTOR                             | DIMENSIONS (mm) | VENDOR | PART NUMBER      |
|--------------------------------------|-----------------|--------|------------------|
| 4.7 $\mu$ H/<br>2.7A <sub>PEAK</sub> | 5.7x5.0x4.7     | Murata | LQH55DN4R7M01K   |
| 6.8 $\mu$ H/<br>3A <sub>PEAK</sub>   | 7.3x6.8x3.2     | TDK    | RLF7030T-6R8M2R8 |

### Rectifier Diode (Buck Converter)

A Schottky diode is recommended for fast recovery and low forward voltage. The reverse voltage rating should be higher than the maximum input voltage. The peak current rating is 2.5A, and the average current is given by Equation 13:

$$I_{\text{avg}} = (1 - D) \cdot I_{\text{O}} \quad (\text{EQ. 13})$$

Where  $I_{\text{O}}$  is the output current of buck converter. The following table shows some diode recommended.

TABLE 8. BUCK RECTIFIER DIODE RECOMMENDATION

| DIODE      | $V_{\text{R}}/I_{\text{AVG}}$ RATING | PACKAGE | VENDOR                  |
|------------|--------------------------------------|---------|-------------------------|
| PMEG2020EJ | 20V/2A                               | SOD323F | Philips Semiconductors  |
| SS22       | 20V/2A                               | SMB     | Fairchild Semiconductor |

### Output Capacitor (Buck Converter)

Four 10µF or two 22µF ceramic capacitors are recommended for this part. The overshoot and undershoot will be reduced with more capacitance, but the recovery time will be longer.

**TABLE 9. BUCK OUTPUT CAPACITOR RECOMMENDATION**

| CAPACITOR  | SIZE | VENDOR | PART NUMBER    |
|------------|------|--------|----------------|
| 10µF/6.3V  | 0805 | TDK    | C2012X5R0J106M |
| 10µF/6.3V  | 0805 | Murata | GRM21BR60J106K |
| 22µF/6.3V  | 1210 | TDK    | C3216X5R0J226M |
| 100µF/6.3V | 1206 | Murata | GRM31CR60J107M |

### PI Loop Compensation (Buck Converter)

The buck converter of ISL97653A can be compensated by a RC network connected from CM2 pin to ground.  $C_8 = 4.7\text{nF}$  and  $R_{20} = 10\text{k}$  RC network is used in the demo board. A larger value resistor can lower the transient overshoot, however, at the expense of stability of the loop.

The stability can be optimized in a similar manner to that described in “PI Loop Compensation (Boost Converter)” on page 12.

### Bootstrap Capacitor (C<sub>13</sub>)

This capacitor provides the supply to the high driver circuitry for the buck MOSFET. The bootstrap supply is formed by an internal diode and capacitor combination. A 1µF is recommended for ISL97653A. A low value capacitor can lead to overcharging and in turn damage the part.

During very light loads, the on-time of the low side diode may be insufficient to replenish the bootstrap capacitor voltage. Additionally, if  $V_{IN} - V_{BUCK} < 1.5\text{V}$ , the internal MOSFET pull-up device may be unable to turn-on until  $V_{LOGIC}$  falls. Hence, there is a minimum load requirement in this case. The minimum load can be adjusted by the feedback resistors to FBL.

### Charge Pump Controllers (V<sub>ON</sub> and V<sub>OFF</sub>)

The ISL97653A includes 2 independent charge pumps (see charge pump block and connection diagram). The negative charge pump inverts the SUPN voltage and provides a regulated negative output voltage. The positive charge pump doubles or triples the SUPP voltage and provides a regulated positive output voltage. The regulation of both the negative and positive charge pumps is controlled by internal comparators that sense the output voltage. These sensed voltages are then compared to scaled internal reference voltages.

Charge pumps use pulse width modulation to adjust the pump period, depending on the load present. The pumps can provide 100mA for V<sub>OFF</sub> and 40mA for V<sub>ON</sub>.

### Positive Charge Pump Design Consideration

All positive charge pump diodes (D1, D2 and D3 shown in the “NEGATIVE CHARGE PUMP BLOCK DIAGRAM” on page 16) for x2 (doubler) and x3 (Tripler) modes of operation are included in the ISL97653A. During the chip start-up sequence the mode of operation is automatically detected when the charge pump is enabled. With both C<sub>7</sub> and C<sub>8</sub> present, the x3 mode of operation is detected. With C<sub>7</sub> present, C<sub>8</sub> open and with C<sub>1</sub> shorted to C<sub>2+</sub>, the x2 mode of operation will be detected.

Internal switches M1, M2 and M3 isolate P<sub>OUT</sub> from SUPP until the charge pump is enabled. This is important for TFT applications that require the negative charge pump output (V<sub>OFF</sub>) and A<sub>VDD</sub> supplies to be established prior to P<sub>OUT</sub>.

The maximum P<sub>OUT</sub> charge pump current can be estimated from the following equations assuming a 50% switching duty:

$$I_{MAX}(2x) \sim \text{min of } 40\text{mA or } \frac{2 \cdot V_{SUPP} - 2 \cdot V_{DIODE}(2 \cdot I_{MAX}) - V(V_{ON})}{(2 \cdot (2 \cdot R_{ONH} + R_{ONL}))} \cdot 0.95\text{A}$$

$$I_{MAX}(3x) \sim \text{min of } 40\text{mA or } \frac{3 \cdot V_{SUPP} - 3 \cdot V_{DIODE}(2 \cdot I_{MAX}) - V(V_{ON})}{(2 \cdot (3 \cdot R_{ONH} + 2 \cdot R_{ONL}))} \cdot 0.95\text{V} \quad (\text{EQ. 14})$$

Note:  $V_{DIODE}(2 \cdot I_{MAX})$  is the on-chip diode voltage as a function of  $I_{MAX}$  and  $V_{DIODE}(40\text{mA}) < 0.7\text{V}$ .

© Copyright Intersil Americas LLC 2007-2010. All Rights Reserved.

All trademarks and registered trademarks are the property of their respective owners.

For additional products, see [www.intersil.com/en/products.html](http://www.intersil.com/en/products.html)

Intersil products are manufactured, assembled and tested utilizing ISO9001 quality systems as noted in the quality certifications found at [www.intersil.com/en/support/qualandreliability.html](http://www.intersil.com/en/support/qualandreliability.html)

Intersil products are sold by description only. Intersil may modify the circuit design and/or specifications of products at any time without notice, provided that such modification does not, in Intersil's sole judgment, affect the form, fit or function of the product. Accordingly, the reader is cautioned to verify that datasheets are current before placing orders. Information furnished by Intersil is believed to be accurate and reliable. However, no responsibility is assumed by Intersil or its subsidiaries for its use; nor for any infringements of patents or other rights of third parties which may result from its use. No license is granted by implication or otherwise under any patent or patent rights of Intersil or its subsidiaries.

For information regarding Intersil Corporation and its products, see [www.intersil.com](http://www.intersil.com)

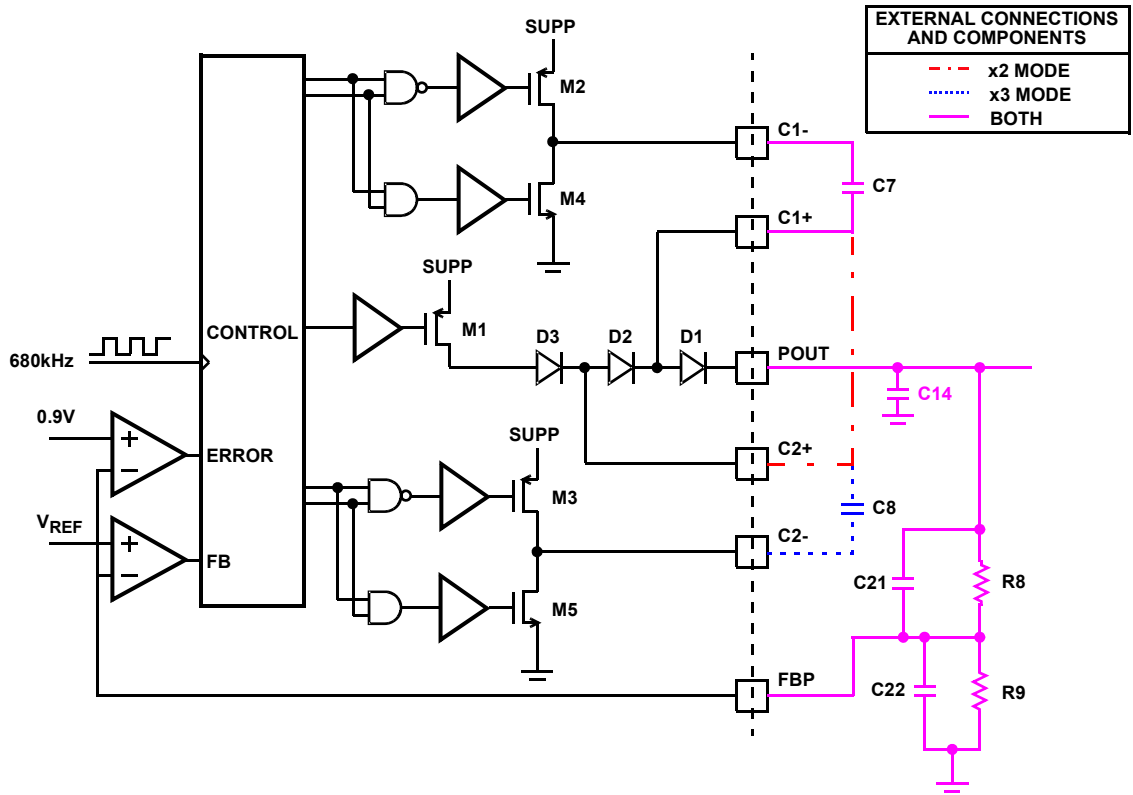

FIGURE 16. VON FUNCTION DIAGRAM

In voltage doubler configuration, the maximum  $V_{ON}$  is as given by the following equation:

$$V_{ON\_MAX(2x)} = 2 \cdot (V_{SUPP} - V_{DIODE}) - 2 \cdot I_{OUT} \cdot (2 \cdot R_{ONH} + R_{ONL}) \quad (EQ. 15)$$

The maximum  $V_{OFF}$  output voltage of a single stage charge pump is:

$$V_{OFF\_MAX(2x)} = -V_{SUPP} + V_{DIODE} + 2 \cdot I_{OUT} \cdot (R_{ON(NOUT)H} + R_{ON(NOUT)L}) \quad (EQ. 18)$$

For Voltage Tripler:

$$V_{ON\_MAX(3x)} = 3 \cdot (V_{SUPP} - V_{DIODE}) - 2 \cdot I_{OUT} \cdot (3 \cdot R_{ONH} + 2 \cdot R_{ONL}) \quad (EQ. 16)$$

$R_6$  and  $R_7$  in the “Typical Application Diagram” on page 5 determine  $V_{OFF}$  output voltage.

$$V_{OFF} = V_{FBN} \cdot \left(1 + \frac{R_7}{R_6}\right) - V_{REF} \cdot \left(\frac{R_7}{R_6}\right) \quad (EQ. 19)$$

$V_{ON}$  output voltage is determined by the following equation:

$$V_{ON} = V_{FBP} \cdot \left(1 + \frac{R_8}{R_9}\right)$$

(EQ. 17) *\*Although in the given typical application diagram, SUPP and SUPN are connected to AVDD, depending on a specific application, SUPN and/or SUPP could be connected to either AVDD or VIN.*

**Negative Charge Pump Design Consideration**

The negative charge pump consists of an internal switcher M1, M2 which drives external steering diodes D2 and D3 via a pump capacitor ( $C_{12}$ ) to generate the negative  $V_{OFF}$  supply. An internal comparator (A1) senses the feedback voltage on FBN and turns on M1 for a period up to half a CLK period to maintain  $V_{(FBN)}$  in regulated operation at 0.2V. External feedback resistor  $R_6$  is referenced to  $V_{REF}$ .

Faults on  $V_{OFF}$  which cause  $V_{FBN}$  to rise to more than 0.4V, are detected by comparator (A2) and cause the fault detection system to start the internal fault timer which will cause the chip to power down if the fault persists.

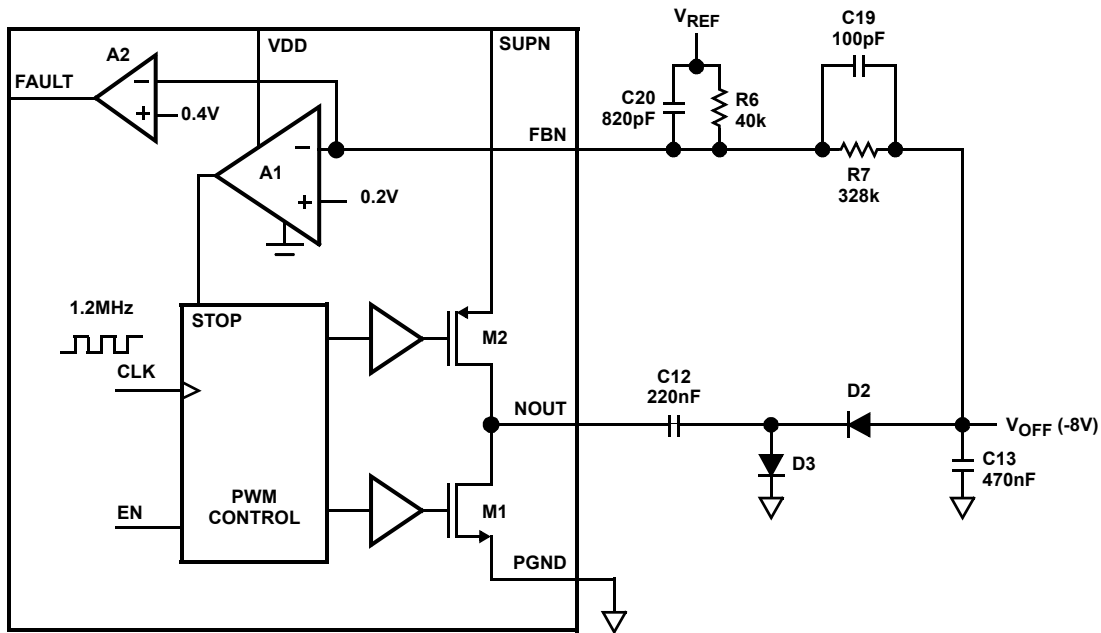

FIGURE 17. NEGATIVE CHARGE PUMP BLOCK DIAGRAM

### *V<sub>ON</sub> Slice Circuit*

The  $V_{ON}$  slice circuit functions as a three way multiplexer, switching the voltage on COM between ground, DRN and POUT, under control of the start-up sequence and the CTL pin.

During the start-up sequence, COM is pulled to ground via an NDMOS FET with  $r_{DS(ON)}$  of 260Ω. After the start-up sequence has completed, CTL is enabled and acts as a multiplexer control such that if CTL is low, COM connects to DRN through a 30Ω internal MOSFET, and if CTL is high, COM connects to POUT internally via a 5Ω MOSFET.

The slew rate of the switch control circuit is mainly restricted by the load capacitance at COM pin and is given by Equation 20:

$$\frac{\Delta V}{\Delta t} = \frac{V_g}{(R_i \parallel R_L) \times C_L} \quad (\text{EQ. 20})$$

Where  $V_g$  is the supply voltage applied to DRN or voltage at POUT, which range is from 0V to 30V.  $R_i$  is the resistance between COM and DRN or POUT including the internal MOSFET  $r_{DS(on)}$ , the trace resistance and the resistor inserted,  $R_L$  is the load resistance of  $V_{ON}$  slice circuit, and  $C_L$  is the load capacitance of switch control circuit.

In the Typical Application Circuit,  $R_8$ ,  $R_9$  and  $C_{22}$  give the bias to DRN based on Equation 21:

$$V_{DRN} = \frac{V_{ON} \cdot R_9 + AV_{DD} \cdot R_8}{R_9 + R_8} \quad (\text{EQ. 21})$$

And  $R_{10}$  can be adjusted to adjust the slew rate.

### *V<sub>LOGIC2</sub> LDO*

An LDO controller is also integrated to provide a second logic supply. The LDO-CTL pin drives the base of an external

transistor which should be sized for the current required. A resistor divider is used to set the output voltage by feeding back a reference voltage to LDO-FB. The internal feedback reference is 1.215V.

### *HVS Operation*

When the HVS input is taken high, the ISL97653A enters HVS test mode. In this mode, the output of  $A_{VDD}$  is increased by switching RSET to ground, and the  $A_{VDD}$  is set to:

$$A_{VDD} = \frac{R_3 + R_x}{R_x} \times V_{FBB} \quad (\text{EQ. 22})$$

Where  $R_x$  is the value of  $R_4$  in parallel with  $R_5$ .  $A_{VDD}$  voltage higher than the maximum rating of the boost MOSFET may damage the part.

### *Fault Protection*

The ISL97653A incorporates a number of fault protection schemes.  $A_{VDD}$ ,  $V_{ON}$ , and  $V_{OFF}$  are constantly monitored. If fault conditions are detected for longer than 1ms on these FB inputs, the device stops switching and the outputs are disconnected. The ISL97653A also integrates over-temp and over current protection.

### *Supply Sequencing*

When the input voltage  $V_{IN}$  is higher than 4V(UVLO),  $V_{REF}$ ,  $V_{LOGIC}$ , and  $V_{LOGIC2}$  are turned on.  $V_{LOGIC}$  has a 9ms fixed soft-start at start-up.  $A_{VDD}$ ,  $V_{ON}$ , and  $V_{OFF}$  are dependant on the EN pin.

When EN is taken high, voltage of pin PROT and  $V_{OFF}$  start ramping down. Once the PROT voltage falls below 0.9V,  $A_{VDD}$  starts up with a 9ms fixed soft-start time. Please note if  $V_{OFF}$  is to start earlier than  $A_{VDD}$ , then the SUPN needs to connect to

$V_{IN}$ , and  $V_{IN}$  voltage should be larger than  $V_{OFF}$  absolute value. The delay between  $V_{OFF}$  and  $A_{VDD}$  can be controlled by C30 in the “Typical Application Diagram” on page 5m and is given by Equation 23:

$$t_{DELAY} = (V_{IN} - 0.9V) \times C_{30} / (50\mu A) \quad (EQ. 23)$$

The successful completion of the  $A_{VDD}$  soft-start cycle triggers two simultaneous events.  $V_{ON}$  begins to ramp up and the voltage on CDEL starts ramping up. When the voltage reaches 1.215V,  $V_{ON}$  slice starts.

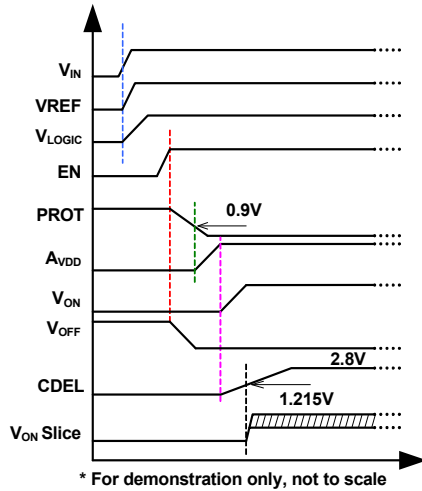

FIGURE 18.

### Temperature Sensor

The ISL97653A also includes a temperature output for use in system thermal management control. The integrated sensor measures the die temperature over the  $-40^{\circ}\text{C}$  to  $+150^{\circ}\text{C}$  range. Output is in the form of an analog voltage on the TEMP pin in the range of 0V to 3V, which is proportional to the sensed die temperature. Temperature accuracy is  $\pm 8.5^{\circ}\text{C}$  over the  $-40^{\circ}\text{C}$  to  $+150^{\circ}\text{C}$  temperature range.

The device should be disabled by the user when the TEMP pin output reaches 3V ( $= +150^{\circ}\text{C}$  die junction). Operation of the device between  $+125^{\circ}\text{C}$  and  $+150^{\circ}\text{C}$  can be tolerated for short periods, however in order to maximize the life of the IC, it is recommended that the effective continuous operating junction temperature of the die should not exceed  $+125^{\circ}\text{C}$ .

### Fault Sequencing

The ISL97653A has advanced overall fault detection systems including Overcurrent Protection (OCP) for both boost and buck converters, Undervoltage Lockout Protection (UVLP) and Over-Temperature Protection.

Once the peak current flowing through the switching MOSFET of the boost and buck converters triggers the current limit threshold, the PWM comparator will disable the output, cycle by cycle, until the current is back to normal.

### Layout Recommendation

The device's performance including efficiency, output noise, transient response and control loop stability is dramatically affected by the PCB layout. PCB layout is critical, especially at high switching frequency.

There are some general guidelines for layout:

1. Place the external power components (the input capacitors, output capacitors, boost inductor and output diodes, etc.) in close proximity to the device. Traces to these components should be kept as short and wide as possible to minimize parasitic inductance and resistance.
2. Place  $V_{REF}$  and  $V_L$  bypass capacitors close to the pins.
3. Reduce the loop with large AC amplitudes and fast slew rate.
4. The feedback network should sense the output voltage directly from the point of load, and be as far away from LX node as possible.
5. The power ground (PGND) and signal ground (SGND) pins should be connected at only one point.
6. The exposed die plate, on the underneath of the package, should be soldered to an equivalent area of metal on the PCB. This contact area should have multiple via connections to the back of the PCB as well as connections to intermediate PCB layers, if available, to maximize thermal dissipation away from the IC.
7. To minimize the thermal resistance of the package when soldered to a multi-layer PCB, the amount of copper track and ground plane area connected to the exposed die plate should be maximized and spread out as far as possible from the IC. The bottom and top PCB areas especially should be maximized to allow thermal dissipation to the surrounding air.
8. Minimize feedback input track lengths to avoid switching noise pick-up.

A demo board is available to illustrate the proper layout implementation.



# Package Outline Drawing

## L40.6x6

40 LEAD QUAD FLAT NO-LEAD PLASTIC PACKAGE

Rev 3, 10/06

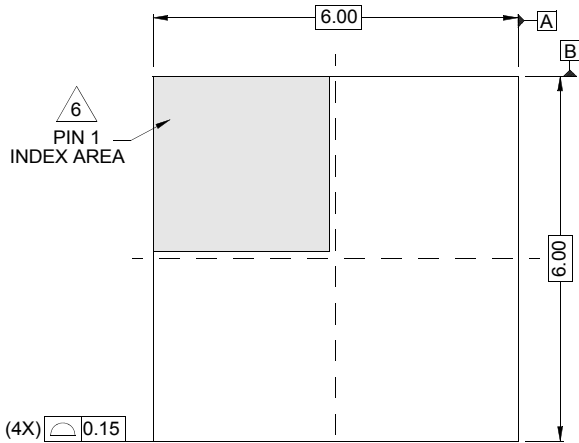

TOP VIEW

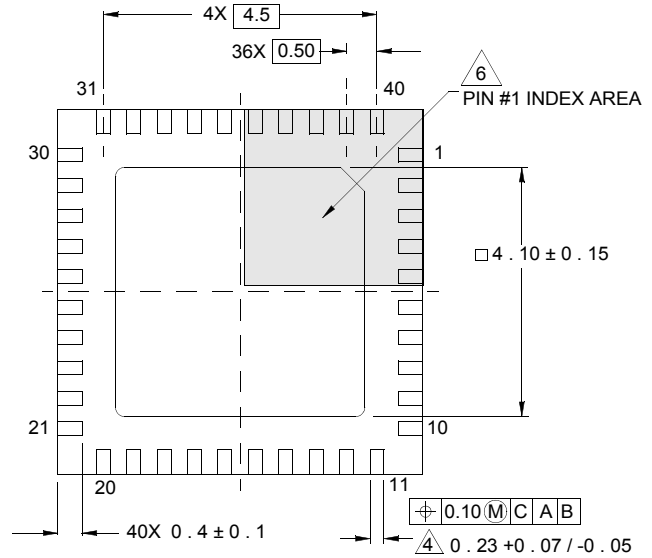

BOTTOM VIEW

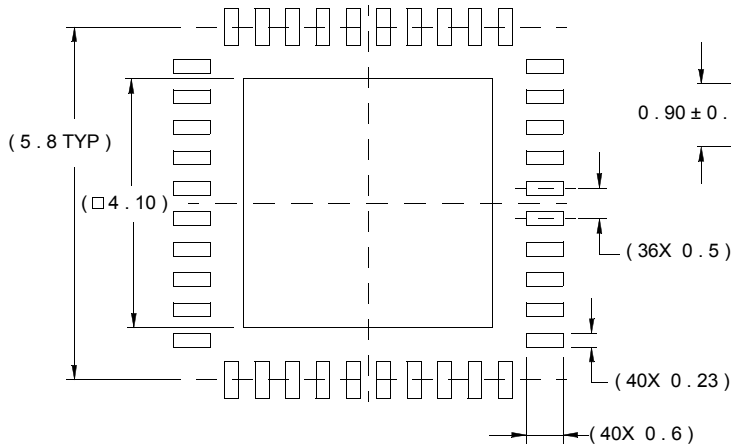

TYPICAL RECOMMENDED LAND PATTERN

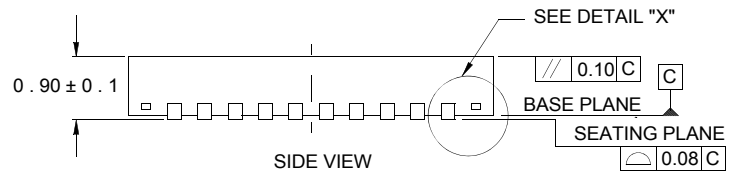

SIDE VIEW

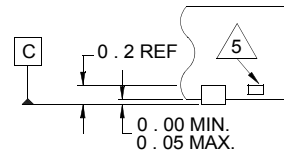

DETAIL "X"

NOTES:

1. Dimensions are in millimeters.  
Dimensions in ( ) for Reference Only.
2. Dimensioning and tolerancing conform to AMSE Y14.5m-1994.
3. Unless otherwise specified, tolerance : Decimal  $\pm 0.05$
4. Dimension b applies to the metallized terminal and is measured between 0.15mm and 0.30mm from the terminal tip.
5. Tiebar shown (if present) is a non-functional feature.
6. The configuration of the pin #1 identifier is optional, but must be located within the zone indicated. The pin #1 identifier may be either a mold or mark feature.

## Looking for pricing, stock, or lifecycle information?

Click below to explore more details on WIN SOURCE:

 [View ISL97653AIRZ-TK on WIN SOURCE](#)

 [Intersil Information](#)

## Optimize Your Supply Chain with WIN SOURCE Solutions

-  Global Sourcing Solution
-  Obsolete Management
-  Cost Control Management
-  Shortage Management
-  Alternative Solution
-  Excess Inventory Management