



**THE DATASHEET OF
ISL94212INZ-T**



ISL94212

Multi-Cell Li-Ion Battery Manager

FN7938
Rev 1.00
April 23, 2015

The **ISL94212** Li-ion battery manager IC supervises up to 12 series connected cells. The part provides accurate monitoring, cell balancing and extensive system diagnostics functions. Three cell balancing modes are provided: Manual Balancing mode, Timed Balancing mode and Auto Balance mode. The Auto Balance mode terminates balancing functions when a charge transfer value has been met.

The ISL94212 communicates to a host microcontroller via an SPI interface and to other ISL94212 devices using a robust, proprietary, two-wire Daisy Chain system.

The ISL94212 is offered in a 64 Ld TQFP package and is specified for an operational temperature range of -40°C to +85°C.

Applications

- Light electric vehicle (LEV); E-Moto; E-Bike
- Battery backup systems; Energy Storage Systems (ESS)
- Solar Farms
- Portable and semi-portable equipment

Features

- Up to 12-cell voltage monitors, support Li-Ion CoO₂, Li-ion Mn₂O₄, and Li-ion FePO₄ chemistries
- Cell voltage measurement accuracy ±10mV
- 13-bit cell voltage measurement
- Pack voltage measurement accuracy ±180mV
- 14-bit pack voltage and temperature measurements
- Cell voltage scan rate of 19.5µs per cell (234µs to scan 12 cells)
- Internal temperature monitoring
- Up to four external temperature inputs
- Robust daisy chain communications system
- Integrated system diagnostics for all key internal functions
- Hardwired and communications based fault notification
- Integrated watchdog shuts down device if communication is lost
- 7µA shutdown current: Enable = V_{SS}
- 2Mbps SPI

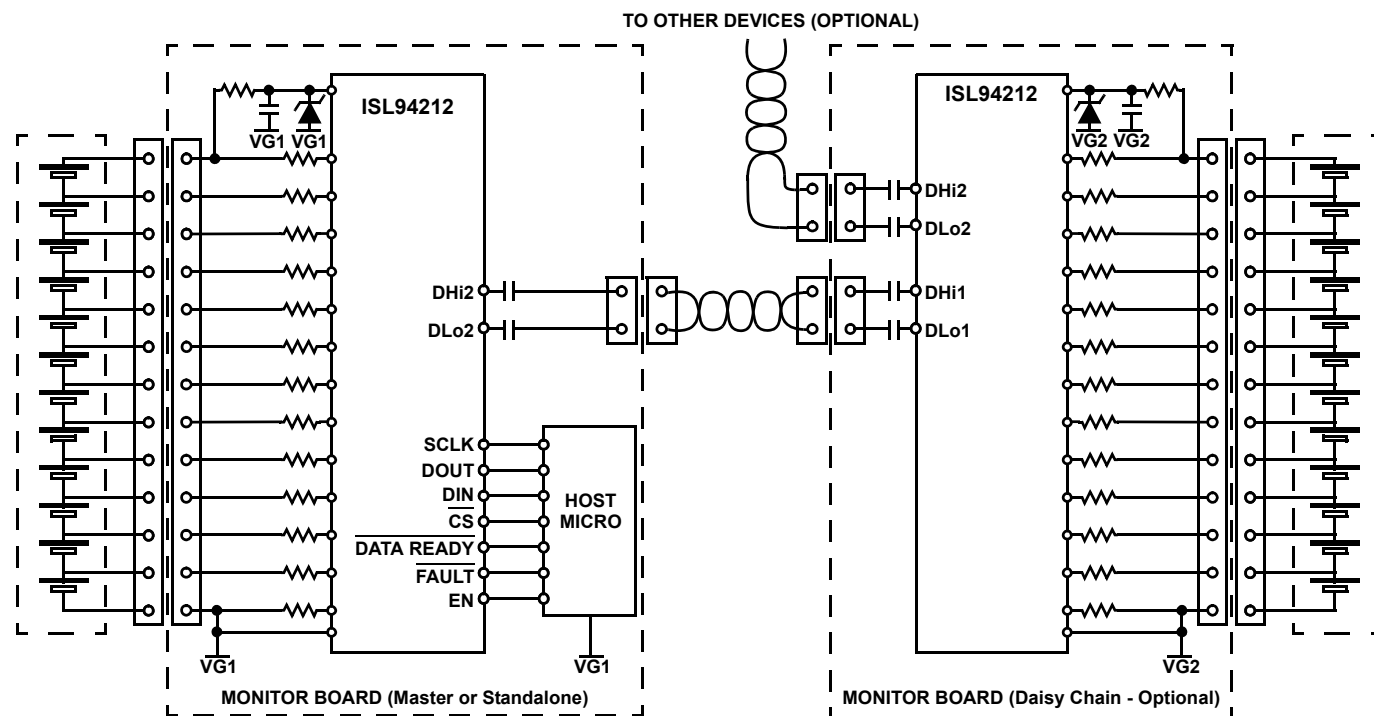

FIGURE 1. TYPICAL APPLICATION

Table of Contents

Ordering Information	4	CRC Calculation	36
Pin Configuration	4	Daisy Chain Addressing	38
Absolute Maximum Ratings	7	Daisy Chain Commands	40
Thermal Information	7	Identify	40
Recommended Operating Conditions	7	ACK (Acknowledge)	42
Electrical Specifications	7	NAK (Not Acknowledge)	42
Timing Diagrams	14	Reset	42
Typical Performance Curves	15	Address All	42
Device Description and Operation	21	Alarm Signals	43
Power Modes	21	Watchdog Function	43
Measurement Modes	21	Communications Faults	44
Measurement Mode Commands	21	Communication Failure	44
Scan Once	22	Scan Counter	45
Scan Voltages	22	Daisy Chain Communications Conflicts	45
Scan Temperatures	22	Memory Checksum	45
Scan Mixed	22	Settling Time Following Diagnostic Activity	45
Scan Wires	22	Open Wire Test	45
Scan All	22	Cell Balancing	45
Scan Continuous	23	Fault Signal Filtering	46
Measure	23	Fault Diagnostics	46
Cell Voltage Measurement Accuracy	24	Sleep Mode	50
Temperature Monitoring	24	Wakeup	50
Cell Balancing Functions	25	Fault Response in Sleep Mode	50
Balance Setup Register	25	Communication and Measurement Diagrams	50
Balance Status Register	26	Measurement Timing Diagrams	51
Manual Balance Mode	26	Command Timing Diagram	52
Timed Balance Mode	27	Response Timing Diagrams	53
Auto Balance Mode	27	Communication and Measurement Timing Tables	56
Balance FET Drivers	29	Measurement Timing Tables	56
Device Setup Register	30	Command Timing Tables	57
Cell Balance Enabled Register	30	Response Timing Tables	58
System Configuration	31	System Registers	62
SPI Interface	31	Register Descriptions	62
Full Duplex Operation	31	Cell Voltage Data	62
Half Duplex Operation	32	Temperature Data, Secondary Voltage Reference Data, Scan Count	62
Non-daisy Chain Systems	33	Fault Registers	63
Normal Communications	33	Setup Registers	66
Alarm Signals	33	Cell Balance Registers	69
Communication Faults	33	Reference Coefficient Registers	69
Fault Response in Sleep Mode	34	Cells In Balance Register	70
Example Communications	34	Device Commands	70
Daisy Chain Systems	34	Nonvolatile Memory (EEPROM) Checksum	71
Daisy Chain Ports	34	Applications Circuits Information	72
Communications Protocol	35	Typical Applications Circuits	72
Communication Sequences	36	Typical Application Circuits	73
		Notes on Board Layout	77

Component Selection	78
Operating the ISL94212 with Reduced Cell Counts	78
Typical Application Circuits	79
Power Supplies	82
Voltage Reference Bypass Capacitor	82
Cell Balancing Circuits	82
Cell Voltage Measurements During Balancing	83
Balancing with Scan Continuous Mode Enabled	83
Daisy Chain Communications System	83
External Inputs	85
Board Level Calibration	86
Worked Examples	86
Voltage Reference Check Calculation	86
Cell Balancing – Manual Mode	87
Cell Balancing – Timed Mode	87
Cell Balancing – Auto Mode	88
Register Map	90
Revision History	95
Package Outline Drawing	96

Ordering Information

PART NUMBER (Notes 2, 3, 4)	PART MARKING	TRIM VOLTAGE, V _{NOM} (V)	TEMP. RANGE (°C)	PACKAGE (RoHS Compliant)	PKG. DWG. #
ISL94212INZ (Note 1)	ISL94212INZ	3.3	-40 to +85	64 Ld TQFP	Q64.10x10D
ISL94212EVKIT1Z	Evaluation Kit				

NOTES:

1. Add "-T*" suffix for tape and reel. Please refer to [TB347](#) for details on reel specifications.
2. These Intersil Pb-free plastic packaged products employ special Pb-free material sets, molding compounds/die attach materials, and 100% matte tin plate plus anneal (e3 termination finish, which is RoHS compliant and compatible with both SnPb and Pb-free soldering operations). Intersil Pb-free products are MSL classified at Pb-free peak reflow temperatures that meet or exceed the Pb-free requirements of IPC/JEDEC J STD-020.
3. For Moisture Sensitivity Level Rating (MSL) for the package, please see the Intersil [ISL94212](#). For more information on handling and processing moisture sensitive devices, please see Techbrief [TB363](#).
4. For other trim options, please contact [Marketing](#).

Pin Configuration

ISL94212
(64 LD 10x10 TQFP)
TOP VIEW

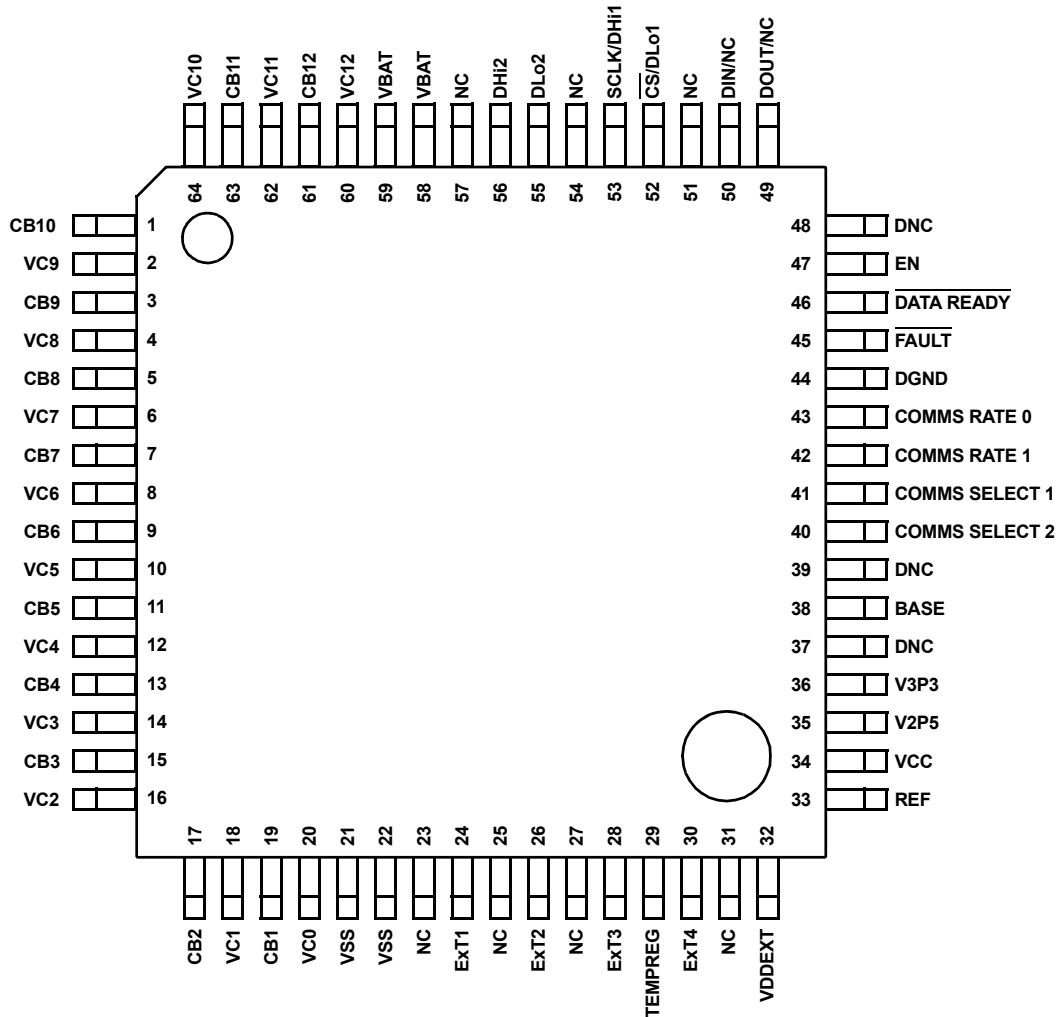

Pin Descriptions

SYMBOL	PIN NUMBER	DESCRIPTION
VC0, VC1, VC2, VC3, VC4, VC5, VC6, VC7, VC8, VC9, VC10, VC11, VC12	20, 18, 16, 14, 12, 10, 8, 6, 4, 2, 64, 62, 60	Battery cell voltage inputs. VCn connects to the positive terminal of CELLn and the negative terminal of CELLn+1. (VC12 connects only to the positive terminal of CELL12 and VC0 only connects with the negative terminal of CELL1.)
CB1, CB2, CB3, CB4, CB5, CB6, CB7, CB8, CB9, CB10, CB11, CB12	19, 17, 15, 13, 11, 9, 7, 5, 3, 1, 63, 61	Cell Balancing FET control outputs. Each output controls an external FET which provides a current path around the cell for balancing.
VBAT	58, 59	Main IC Supply pins. Connect to the most positive terminal in the battery string.
VSS	21, 22	Ground. These pins connect to the most negative terminal in the battery string.
Ext1, Ext2, Ext3, Ext4	24, 26, 28, 30	External temperature monitor or general purpose inputs. The temperature inputs are intended for use with external resistor networks using NTC type thermistor sense elements but may also be used as general purpose analog inputs at the user's discretion. 0V to 2.5V input range.
TEMPREG	29	Temperature monitor voltage regulator output. This is a switched 2.5V output, which supplies a reference voltage to external NTC thermistor circuits to provide ratiometric ADC inputs for temperature measurement.
VDDEXT	32	External V3P3 supply input/output. Connected to the V3P3 pin via a switch, this pin may be used to power external circuits from the V3P3 supply. The switch is open when the ISL94212 is placed in Sleep mode .
REF	33	2.5V voltage reference decoupling pin. Connect a 2.0 μ F to 2.5 μ F X7R capacitor to VSS. Do not connect any additional external load to this pin.
VCC	34	Analog supply voltage input. Connect to V3P3 via a 33 Ω resistor. Connect a 1 μ F capacitor to ground.
V2P5	35	Internal 2.5V digital supply decoupling pin. Connect a 1 μ F capacitor to DGND.
V3P3	36	3.3V digital supply voltage input. Connect the emitter of the external NPN regulator transistor to this pin. Connect a 1 μ F capacitor to DGND.
Base	38	Regulator control pin. Connect the external NPN transistor's base. Do not let this pin float,
DNC	37, 39, 48	Do not connect. Leave pins floating.
Comms Select 1	41	Communications port 1 mode select pin. Connect via a 1k Ω resistor to V3P3 for Daisy Chain communications on port 1 or to DGND for SPI operation on port 1.
Comms Select 2	40	Communications port 2 mode select pin. Connect via a 1k Ω resistor to V3P3 to enable port 2 or to DGND to disable this port.
Comms Rate 0, Comms Rate 1	43, 42	Daisy Chain communications data rate setting. Connect via a 1k Ω resistor to DGND ('0') or to V3P3 ('1') to select between various communication data rates.
DGND	44	Digital Ground.
$\overline{\text{Fault}}$	45	Logic fault output. Asserted low if a fault condition exists.
$\overline{\text{Data Ready}}$	46	SPI data ready. Asserted low when the device is ready to transmit data to the host microcontroller.
EN	47	Enable input. Tie to V3P3 to enable the part. Tie to DGND to disable (all IC functions are turned off).
DOUT/NC	49	Serial Data Output (SPI) or NC (Daisy Chain). 0V to 3.3V push-pull output.
DIN/NC	50	Serial Data Input (SPI) or NC (Daisy Chain). 0V to 3.3V input.
$\overline{\text{CS}}/\text{DLo1}$	52	Chip-Select, active low 3.3V input (SPI) or Daisy Chain port 1 Lo connection.
SCLK/DHi1	53	Serial-Clock Input (SPI) or Daisy Chain port 1 Hi connection.
DHi2	56	Daisy Chain port 2 Hi connection.
DLo2	55	Daisy Chain port 2 Lo connection.
NC	23, 25, 27, 31, 51, 54, 57	No internal connection.

Absolute Maximum Ratings

Unless otherwise specified. With respect to VSS.

DIN, SCLK, $\overline{\text{CS}}$, DOUT, $\overline{\text{Data Ready}}$, Comms Select n, ExTn, TEMPREG, REF, V3P3, VCC, $\overline{\text{Fault}}$, V2P5	-0.2V to 4.1V
Comms Rate n, Base, EN, VDDEXT	-0.2V to 2.9V
VBAT	-0.5V to 63V
DHi1, DLo1, DHi2, DLo2	-0.5V to (VBAT + 0.5V)
VC0	-0.5V to + 9.0V
VC1	-0.5V to + 18V
VC2	-0.5V to + 18V
VC3	-0.5V to + 27V
VC4	-0.5V to + 27V
VC5	-0.5V to + 36V
VC6	-0.5V to + 36V
VC7	-0.5V to + 45V
VC8	-0.5V to + 45V
VC9	-0.5V to + 54V
VC10	-0.5V to + 63V
VC11	-0.5V to + 63V
VC12	-0.5V to + 63V
VCn (for n = 0 to 12)	-0.5 to VBAT + 0.5V
CBn (for n = 1 to 12)	-0.5 to VBAT + 0.5V
CBn (for n = 1 to 9)	V(VCn-1) - 0.5V to V(VCn-1) + 9V
CBn (for n = 10 to 12)	V(VCn) - 9V to V(VCn) + 0.5V
Current into VCn, VBAT, VSS (Latch up Test)	$\pm 100\text{mA}$
ESD Rating		
Human Body Model (Tested per JESD22-A114F)	2kV
Machine Model (Tested per JESD22A115-A)	200V
Charge Device Model (Tested per JESD22-C101D)	750V
Latch-up (Tested per JESD-78B; Class 2, Level A)	100mA

NOTE: DOUT, $\overline{\text{Data Ready}}$, and $\overline{\text{Fault}}$ are digital outputs and should not be driven from external sources. V2P5, REF, TEMPREG and BASE are analog outputs and should not be driven from external sources.

CAUTION: Do not operate at or near the maximum ratings listed for extended periods of time. Exposure to such conditions may adversely impact product reliability and result in failures not covered by warranty.

NOTES:

- θ_{JA} is measured with the component mounted on a high effective thermal conductivity test board in free air. See Tech Brief [TB379](#) for details.
- For θ_{JC} , the “case temp” location is taken at the package top center.

Thermal Information

Thermal Resistance (Typical)	θ_{JA} (C/W)	θ_{JC} (C/W)
64 Ld TQFP Package (Notes 5, 6)	42	9
Max Continuous Package Power Dissipation	.400mW	
Storage Temperature	-55°C to +125°C	
Max Operating Junction Temperature	+125°C	
Pb-Free Reflow Profile	see TB493	

Recommended Operating Conditions

T_A , Ambient Temperature Range	-40°C to +85°C
VBAT	6V to 60V
VBAT (Daisy Chain Operation)10V to 60V
VCn (for n = 1 to 12)	V(VCn-1) to V(VCn-1) + 5V
VC0	-0.1V to 0.1V
CBn (for n = 1 to 9)	V(VCn-1) to V(VCn-1) + 9V
CBn (for n = 10 to 12)	V(VCn) - 9V to V(VCn)
DIN, SCLK, $\overline{\text{CS}}$, DOUT, $\overline{\text{Data Ready}}$, Comms Select 1, Comms Select 2, TEMPREG, REF, V3P3, VCC, $\overline{\text{Fault}}$, Comms Rate 0, Comms Rate 1, EN, VDDEXT	0V to 3.6V
Ext1, Ext2, Ext3, Ext4	0V to 2.5V

Electrical Specifications $V_{BAT} = 6$ to 60V, $T_A = -40^\circ\text{C}$ to $+85^\circ\text{C}$, unless otherwise specified. Boldface limits apply across the operating temperature range, -40°C to $+85^\circ\text{C}$.

PARAMETER	SYMBOL	TEST CONDITIONS	MIN (Note 7)	TYP	MAX (Note 7)	UNITS
Power-up Condition Threshold	V _{POR}	V _{BAT} voltage (rising)	4.8	5.1	5.6	V
Power-up Condition Hysteresis	V _{PORhys}			400		mV
Initial Power-up Delay	t _{POR}	Time after V _{POR} condition V _{REF} from 0V to 0.95 x V _{REF(nom)} (EN tied to V3P3) Device can now communicate			27.125	ms
Enable Pin Power-up Delay	t _{PUD}	Delay after EN = 1 to V _{REF} from 0V to 0.95 x V _{REF(nom)} (V _{BAT} = 39.6V) - Device can now communicate			27.125	ms

Electrical Specifications $V_{BAT} = 6$ to $60V$, $T_A = -40^{\circ}C$ to $+85^{\circ}C$, unless otherwise specified. **Boldface limits apply across the operating temperature range, $-40^{\circ}C$ to $+85^{\circ}C$.** (Continued)

PARAMETER	SYMBOL	TEST CONDITIONS	MIN (Note 7)	TYP	MAX (Note 7)	UNITS	
V_{BAT} Supply Current	I_{VBAT}	Non-daisy chain configuration. Device enabled. No communications, ADC, measurement, balancing or open wire detection activity.	6V	10	35	75	μA
			39.6V	10	64	220	μA
			60V	10	90	230	μA
	$I_{VBATMASTER}$	Daisy chain configuration – master device. Enabled. No communications, ADC, measurement, balancing or open wire detection activity.	6V	400	530	660	μA
			39.6V	500	680	900	μA
			60V	550	750	1000	μA
			Peak current when daisy chain transmitting			18	
	$I_{VBATMID}$	Daisy chain configuration – mid stack device. Enabled. No communications, ADC, measurement, balancing or open wire detection activity.	6V	700	1020	1300	μA
			39.6V	900	1250	1600	μA
			60V	1000	1400	1700	μA
			Peak current when daisy chain transmitting			18	
	$I_{VBATTOP}$	Daisy chain configuration – top device. Enabled. No communications, ADC, measurement, balancing or open wire detection activity.	6V	400	530	660	μA
			39.6V	500	680	900	μA
			60V	550	750	1000	μA
			Peak current when daisy chain transmitting			18	
$I_{VBATSLEEP1}$	Sleep mode (EN = 1, daisy chain configuration).		10	19	36	μA	
$I_{VBATSLEEP2}$	Sleep mode (EN = 1, standalone, non-daisy chain)		5	9	18	μA	
$I_{VBATSHDN}$	Shutdown. device "off" (EN = 0) (daisy chain and non-daisy chain configurations)		5	7	18	μA	
V_{BAT} Supply Current Tracking. Sleep Mode.	$I_{VBATASLEEP}$	EN = 1, daisy chain sleep mode configuration. V_{BAT} current difference between any two devices operating at the same temperature and supply voltage.	0		10.5	μA	
V_{BAT} Incremental Supply Current, Balancing	$I_{VBATBAL}$	All balancing circuits on. Incremental current: Add to non-balancing V_{BAT} current. $V_{BAT} = 39.6V$	200	300	400	μA	
V3P3 Regulator Voltage (Normal)	V_{3P3N}	EN = 1, load current range 0 to 5 mA. $V_{BAT} = 39.6V$	3.2	3.35	3.5	V	
V3P3 Regulator Voltage (Sleep)	V_{3P3S}	EN = 1, load current range. No load. (SLEEP). $V_{BAT} = 39.6V$	2.4	2.7	3.05	V	
V3P3 Regulator Control Current	I_{Base}	Current sourced from base output. $V_{BAT} = 6V$	1	1.5		mA	
V3P3 Supply Current	I_{V3P3}	Device enabled No measurement activity, normal mode	0.8	1	1.3	mA	
V_{REF} Reference Voltage	V_{REF}	EN = 1, no load, normal mode		2.5		V	

Electrical Specifications $V_{BAT} = 6$ to $60V$, $T_A = -40^\circ C$ to $+85^\circ C$, unless otherwise specified. **Boldface limits apply across the operating temperature range, $-40^\circ C$ to $+85^\circ C$.** (Continued)

PARAMETER	SYMBOL	TEST CONDITIONS	MIN (Note 7)	TYP	MAX (Note 7)	UNITS
VDDEXT Switch Resistance	R_{VDDEXT}	Switch ON-resistance, $V_{BAT} = 39.6V$	5	12	22	Ω
VCC Supply Current	I_{VCC}	Device enabled (EN = 1). Standalone or daisy configuration. No ADC or daisy chain communications active.	2.0	3.25	5.0	mA
	$I_{VCCACTIVE1}$	Device enabled (EN = 1). Standalone or daisy configuration. Average current during 16ms scan continuous operation. $V_{BAT} = 39.6V$		6.0		mA
	$I_{VCCSLEEP}$	Device enabled (EN = 1). Sleep mode. $V_{BAT} = 39.6V$		2.4		μA
	$I_{VCCSHDN}$	Device disabled (EN = 0). Shutdown mode.	0	1.2	9.0	μA
MEASUREMENT SPECIFICATIONS						
Cell Voltage Input Measurement Range	V_{CELL}	$VC(N) - VC(N-1)$. For design reference.	0		5	V
Cell Monitor Voltage Resolution	$V_{CELLRES}$	$[VC(N)-VC(N-1)]$ LSB step size (13-bit signed number), 5V full scale value		0.61		mV
ISL94212 Cell Monitor Voltage Error (Absolute)	ΔV_{CELLA}	Absolute cell measurement error (Cell measurement error compared with applied voltage with 1k series resistor.) Temperature = $0^\circ C$ to $+50^\circ C$, $V_{CELL} = 2.6V$ to $4.0V$	-10		10	mV
		Temperature = $+50^\circ C$ to $+85^\circ C$, $V_{CELL} = 2.0V$ to $4.3V$	-25		25	mV
		Temperature = $-40^\circ C$ to $0^\circ C$, $V_{CELL} = 2.0V$ to $4.3V$	-35		35	mV
ISL94212 Cell Monitor Voltage Error (Relative)	ΔV_{CELLB}	Relative cell measurement error (Max absolute cell measurement error Min absolute cell measurement error) Temperature = $0^\circ C$ to $+50^\circ C$	0		7.5	mV
		Temperature = $-40^\circ C$ to $0^\circ C$	0		7.5	mV
		Temperature = $+50^\circ C$ to $+85^\circ C$	0		20	mV
Cell Input Current. Note: Cell accuracy figures assume a fixed 1k Ω resistor is placed in series with each VCn pin (n = 0 to 12)	I_{VCELL}	VCO input	-2.0	-1	-0.5	μA
		VC1, VC2, VC3 inputs	-3.0	-2	-0.9	μA
		VC4 input	-0.8	0	0.9	μA
		VC5, VC6, VC7, VC8, VC9, VC10, VC11 inputs	0.5	2	3.2	μA
		VC12 input	0.4	1	2.0	μA
V_{BAT} Monitor Voltage Resolution	V_{BATRES}	ADC resolution referred to input (V_{BAT}) level. 14b unsigned number. Full scale value = 79.67V.		4.863		mV
V_{BAT} Monitor Voltage Error	ΔV_{BAT}	Temperature = $0^\circ C$ to $+50^\circ C$, Measured at $V_{BAT} = 31.2V$ to $43.2V$	-180		180	mV
		Temperature = $0^\circ C$ to $+50^\circ C$, Measured at $V_{BAT} = 24V$ to $48V$	-230		230	mV
		Temperature = $0^\circ C$ to $+50^\circ C$, Measured at $V_{BAT} = 6V$ to $59.4V$	-390		390	mV
		Temperature = $-40^\circ C$ to $+85^\circ C$, Measured at $V_{BAT} = 31.2V$ to $39.6V$	-320		320	mV
		Temperature = $-40^\circ C$ to $+85^\circ C$, Measured at $V_{BAT} = 6V$ to $48V$	-440		440	mV
		Temperature = $-40^\circ C$ to $+85^\circ C$, Measured at $V_{BAT} = 6V$ to $59.4V$	-650		650	mV

Electrical Specifications $V_{BAT} = 6$ to $60V$, $T_A = -40^{\circ}C$ to $+85^{\circ}C$, unless otherwise specified. **Boldface limits apply across the operating temperature range, $-40^{\circ}C$ to $+85^{\circ}C$.** (Continued)

PARAMETER	SYMBOL	TEST CONDITIONS	MIN (Note 7)	TYP	MAX (Note 7)	UNITS
External Temperature Monitoring Regulator	V_{TEMP}	Voltage on TEMPREG output. (0 to 2mA load)	2.475	2.5	2.525	V
External Temperature Output Impedance	R_{TEMP}	Output impedance at TEMPREG pin.	0	0.1	0.2	Ω
External Temperature Input Range	V_{EXT}	ExTn input voltage range. For design reference.	0		2344	mV
External Temperature Input Pull-up	$R_{EXTTEMP}$	Pull-up resistor to $V_{TEMPREG}$ applied to each input during measurement		10		M Ω
External Temperature Input Offset	V_{EXTOFF}	$V_{BAT} = 39.6V$	-12		12	mV
External Temperature Input INL	V_{EXTINL}		-0.65		0.65	mV
External Temperature Input Gain Error	V_{EXTG}		-8		18.5	mV
Internal Temperature Monitor Error	V_{INTMON}			± 10		$^{\circ}C$
Internal Temperature Monitor Resolution	T_{INTRES}	Output resolution (LSB/ $^{\circ}C$). 14b number.		31.9		LSB/ $^{\circ}C$
Internal Temperature Monitor Output	T_{INT25}	Output count at $+25^{\circ}C$		9180		Decimal
OVER-TEMPERATURE PROTECTION SPECIFICATIONS						
Internal Temperature Limit Threshold	T_{INTSD}	Balance stops and auto scan stops. Temperature rising or falling.		150		$^{\circ}C$
External Temperature Limit Threshold	T_{XT}	Corresponding to 0V (min) and $V_{TEMPREG}$ (max) External temperature input voltages higher than 15/16 $V_{TEMPREG}$ are registered as open input faults.	0		16383	Decimal
FAULT DETECTION SYSTEM SPECIFICATIONS						
Undervoltage Threshold	V_{UV}	Programmable. Corresponding to 0V (min) and 5V (max)	0		8191	Decimal
Overvoltage Threshold	V_{OV}	Programmable. Corresponding to 0V (min) and 5V (max)	0		8191	Decimal
V3P3 Power-good Window	V_{3PH}	3.3V Power-good window high threshold. $V_{BAT} = 39.6V$	3.7	3.90	4.05	V
	V_{3PL}	3.3V Power-good window low threshold. $V_{BAT} = 39.6V$	2.5	2.65	2.8	V
V2P5 Power-good Window	V_{2PH}	2.5V Power-good window high threshold. $V_{BAT} = 39.6V$	2.55	2.7	2.9	V
	V_{2PL}	2.5V Power-good window low threshold. $V_{BAT} = 39.6V$	1.90	2.0	2.15	V
VCC Power-good Window	V_{VCCH}	VCC Power-good window high threshold. $V_{BAT} = 39.6V$	3.6	3.75	4.0	V
	V_{VCCL}	VCC Power-good window low threshold. $V_{BAT} = 39.6V$	2.55	2.7	2.85	V
V_{REF} Power-good Window	V_{RPH}	V_{REF} Power-good window high threshold. $V_{BAT} = 39.6V$	2.525	2.7	2.9	V
	V_{RPL}	V_{REF} Power-good window low threshold. $V_{BAT} = 39.6V$	2.0	2.30	2.50	V

Electrical Specifications $V_{BAT} = 6$ to $60V$, $T_A = -40^\circ C$ to $+85^\circ C$, unless otherwise specified. **Boldface limits apply across the operating temperature range, $-40^\circ C$ to $+85^\circ C$.** (Continued)

PARAMETER	SYMBOL	TEST CONDITIONS	MIN (Note 7)	TYP	MAX (Note 7)	UNITS
V _{REF} Reference Accuracy Error	V _{RACC}	V _{REF} value calculated using stored coefficients. V _{BAT} = 39.6V, V _{REF} typical = 2.5V (See "Voltage Reference Check Calculation" on page 86.) Temperature = 0 °C to +50 °C	-15		15	mV
		Temperature = -40 °C to 0 °C	-40		40	mV
		Temperature = +50 °C to +85 °C	-22		22	mV
Voltage Reference Check Timeout	t _{VREF}	Time to check voltage reference value from power-on, enable or wake up		20		ms
Oscillator Check Timeout	t _{OSC}	Time to check main oscillator frequency from power-on, enable or wake up		20		ms
Oscillator Check Filter Time	t _{OSCF}	Minimum duration of fault required for detection		100		ms

CELL OPEN WIRE DETECTION

(See sections "Scan Wires" on page 22, "ISCN, PIN37, PIN39" on page 30, and "Open Wire Test" on page 45.)

Open Wire Current	I _{OW}	ISCN bit = 0; V _{BAT} = 39.6V	0.125	0.15	0.175	mA
		ISCN bit = 1; V _{BAT} = 39.6V	0.85	1.0	1.15	mA
Open Wire Detection Time	t _{OW}	Open wire current source "on" time		4.6		ms
Open VC0 Detection Threshold	V _{VC0}	CELL1 negative terminal (with respect to VSS) V _{BAT} = 39.6V	1.2	1.5	1.8	V
Open VC1 Detection Threshold	V _{VC1}	CELL1 positive terminal (with respect to VSS) V _{BAT} = 39.6V	0.6	0.7	0.8	V
Primary Detection Threshold, VC2 to VC12	V _{VC2_12P}	V(VC(n - 1)) - V(VCn), n = 2 to 12 V _{BAT} = 39.6V	-2	-1.5	0	V
Secondary Detection Threshold, VC2 to VC12	V _{VC2_12S}	Via ADC. VC2 to VC12 only V _{BAT} = 39.6V	-100	-30	50	mV
Open V _{BAT} Fault Detection Threshold	V _{VBO}	VC12 - V _{BAT}		200		mV
Open VSS Fault Detection Threshold	V _{VSS0}	VSS - VC0		250		mV

MEASUREMENT FUNCTION TIMING (Note 8)

Cell Sample Time Start		Time to sample the first cell (CELL12) following \overline{CS} going High. Scan voltages command		65	71.5	μs
Cell Sample Time Duration		Time to scan all 12 cells (sample of CELL12 to sample of CELL1) scan voltages command.		233	257	μs
Scan Voltages Processing Time		Time from start of scan to registers loaded to $\overline{DATA READY}$ going low		770	847	μs
Scan Temperatures Processing Time		Time from start of scan to registers loaded to $\overline{DATA READY}$ going low		2690	2959	μs
Scan Mixed Processing Time		Time from start of scan to registers loaded to $\overline{DATA READY}$ going low		830	913	μs
Scan Wires Processing Time		Time from start of scan to registers loaded to $\overline{DATA READY}$ going low		59.4	65.3	ms
Scan All Processing Time		Time from start of scan to registers loaded to $\overline{DATA READY}$ going low		63.2	69.5	ms

Electrical Specifications $V_{BAT} = 6$ to $60V$, $T_A = -40^\circ C$ to $+85^\circ C$, unless otherwise specified. **Boldface limits apply across the operating temperature range, $-40^\circ C$ to $+85^\circ C$.** (Continued)

PARAMETER	SYMBOL	TEST CONDITIONS	MIN (Note 7)	TYP	MAX (Note 7)	UNITS
Measure Cell Voltage Processing Time		Time from start of measurement to register(s) loaded to <u>DATA READY</u> going low		180	198	μs
Measure V_{BAT} Voltage Processing Time		Time from start of measurement to register(s) loaded to <u>DATA READY</u> going low		130	143	μs
Measure Internal Temperature Processing Time		Time from start of measurement to register(s) loaded to <u>DATA READY</u> going low		110	121	μs
Measure External Temperature Input Processing Time		Time from start of measurement to register(s) loaded to <u>DATA READY</u> going low		2520	2772	μs
Measure Secondary Voltage Reference Time		Time from start of measurement to register(s) loaded to <u>DATA READY</u> going low		2520	2772	μs
CELL BALANCE OUTPUT SPECIFICATIONS						
Cell Balance Pin Output Impedance	R_{CBL}	CBn output off impedance between CB(n) to VC(n-1): cells 1 to 9 and between CB(n) to VC(n): cells 10 to 12.	3	4	5	M Ω
Cell Balance Output Current	I_{CBH1}	CBn output on. (CB1-CB9); $V_{BAT} = 39.6V$; device sinking current.	-28	-25	-21	μA
	I_{CBH2}	CBn output on. (CB10-CB12); $V_{BAT} = 39.6V$; device sourcing current.	21	25	28	μA
Cell Balance Output Leakage in Shutdown	I_{CBSD}	EN = GND. $V_{BAT} = 39.6V$.	-500	10	700	nA
External Cell Balance FET Gate Voltage	VGS	CBn Output on; External 320k Ω between VCn and CBn (n = 10 to 12) and between CBn and VCn-1 (n = 1 to 9)	7.05	8.0	8.95	V
Internal Cell Balance Output Clamp	VCBCL	$I_{CB} = 100\mu A$.	8.9			V
LOGIC INPUTS: SCLK, \overline{CS}, DIN						
Low Level Input Voltage	VIL				0.8	V
High Level Input Voltage	VIH		1.75			V
Input Hysteresis	VHYS		100			mV
Input Current	IIN	$0V < V_{IN} < V3P3$	-1		+1	μA
Input Capacitance	CIN				10	pF
LOGIC INPUTS: EN, COMMS SELECT1, COMMS SELECT2, COMMS RATE 0, COMMS RATE 1						
Low Level Input Voltage	VIL				0.3*V3P3	V
High Level Input Voltage	VIH		0.7*V3P3			V
Input Hysteresis	VHYS		0.05*V3P3			V
Input Current	IIN	$0V < V_{IN} < V3P3$	-1		+1	μA
Input Capacitance	CIN				10	pF
LOGIC OUTPUTS: DOUT, \overline{FAULT}, DATA READY						
Low Level Output Voltage	VOL1	At 3mA sink current	0		0.4	V
	VOL2	At 6mA sink current	0		0.6	V
High Level Output Voltage	VOH1	At 3mA source current	V3P3 - 0.4V		V3P3	V
	VOH2	At 6mA source current	V3P3 - 0.6V		V3P3	V

Electrical Specifications $V_{BAT} = 6$ to $60V$, $T_A = -40^{\circ}C$ to $+85^{\circ}C$, unless otherwise specified. **Boldface limits apply across the operating temperature range, $-40^{\circ}C$ to $+85^{\circ}C$.** (Continued)

PARAMETER	SYMBOL	TEST CONDITIONS	MIN (Note 7)	TYP	MAX (Note 7)	UNITS
SPI INTERFACE TIMING (See Figures 2 and 3)						
SCLK Clock Frequency	f_{SCLK}				2	MHz
Pulse Width of Input Spikes Suppressed	t_{IN1}		50		200	ns
Enable Lead Time	t_{LEAD}	Chip select low to ready to receive clock data	200			ns
Clock High Time	t_{HIGH}		200			ns
Clock Low Time	t_{LOW}		200			ns
Enable Lag Time	t_{LAG}	Last data read clock edge to chip select high.	250			ns
CHIP SELECT High Time	$t_{CS:WAIT}$	Minimum high time for \overline{CS} between bytes.	200			ns
Slave Access Time	t_A	Chip select low to DOUT active.			200	ns
Data Valid Time	t_V	Clock low to DOUT valid.			350	ns
Data Output Hold Time	t_{HO}	Data hold time after falling edge of SCLK.	0			ns
DOUT Disable Time	t_{DIS}	DOUT disabled following rising edge of \overline{CS} .			240	ns
Data Setup Time	t_{SU}	Data input valid prior to rising edge of SCLK.	100			ns
Data Input Hold Time	t_{HI}	Data input to remain valid following rising edge of SCLK.	80			ns
Data Ready Start Delay Time	$t_{DR:ST}$	Chip select high to $\overline{Data Ready}$ low.	100			ns
Data Ready Stop Delay Time	$t_{DR:SP}$	Chip select high to $\overline{Data Ready}$ high.			750	ns
Data Ready High Time	$t_{DR:WAIT}$	Time between bytes.	0.6			μs
SPI Communications Timeout	$t_{SPI:TO}$	Time the \overline{CS} remains high before SPI communications time out - requiring the start of a new command.		100		μs
DOUT Rise Time	t_R	Up to 50pF load.			30	ns
DOUT Fall Time	t_F	Up to 50pF load.			30	ns
DAISY CHAIN COMMUNICATIONS INTERFACE: DHI1, DLo1, DHI2, DLo2						
Daisy Chain Clock Frequency		Comms Rate (0, 1) = 11	450	500	550	kHz
		Comms Rate (0, 1) = 10	225	250	275	kHz
		Comms Rate (0, 1) = 01	112.5	125	137.5	kHz
		Comms Rate (0, 1) = 00	56.25	62.5	68.75	kHz
Common Mode Reference Voltage			$V_{BAT}/2$		V	

NOTES:

- Compliance to datasheet limits is assured by one or more methods: production test, characterization and/or design.
- Scan and Measurement start times are synchronized by the receiver to the falling edge of the 24th clock pulse (Daisy Chain systems) or to the falling edge of the 16th clock pulse (non-daisy chain, single device systems) of the Scan or Measure command. Clock pulses are at the SCLK pin for master and standalone devices, and at the DHI/DLo1 pins for middle and top daisy chain devices. Max values are based on characterization of the internal clock and are not 100% tested.
- Biasing setup as in [Figure 57 on page 82](#) or equivalent.

Timing Diagrams

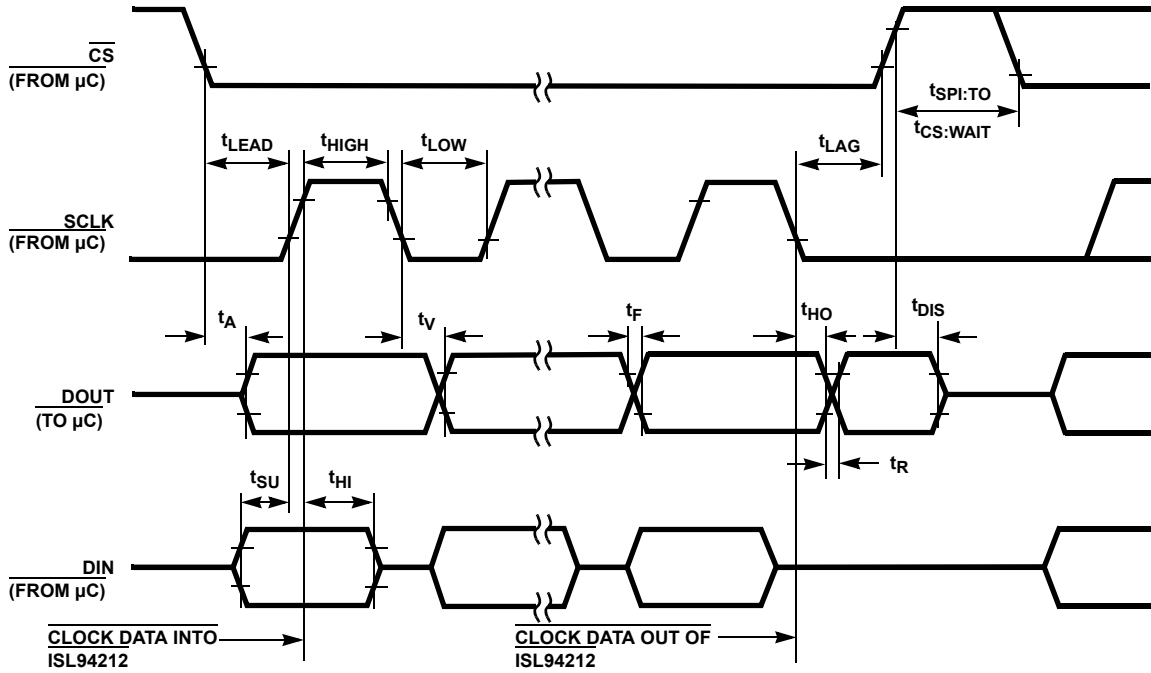

FIGURE 2. SPI FULL DUPLEX (4-WIRE) INTERFACE TIMING

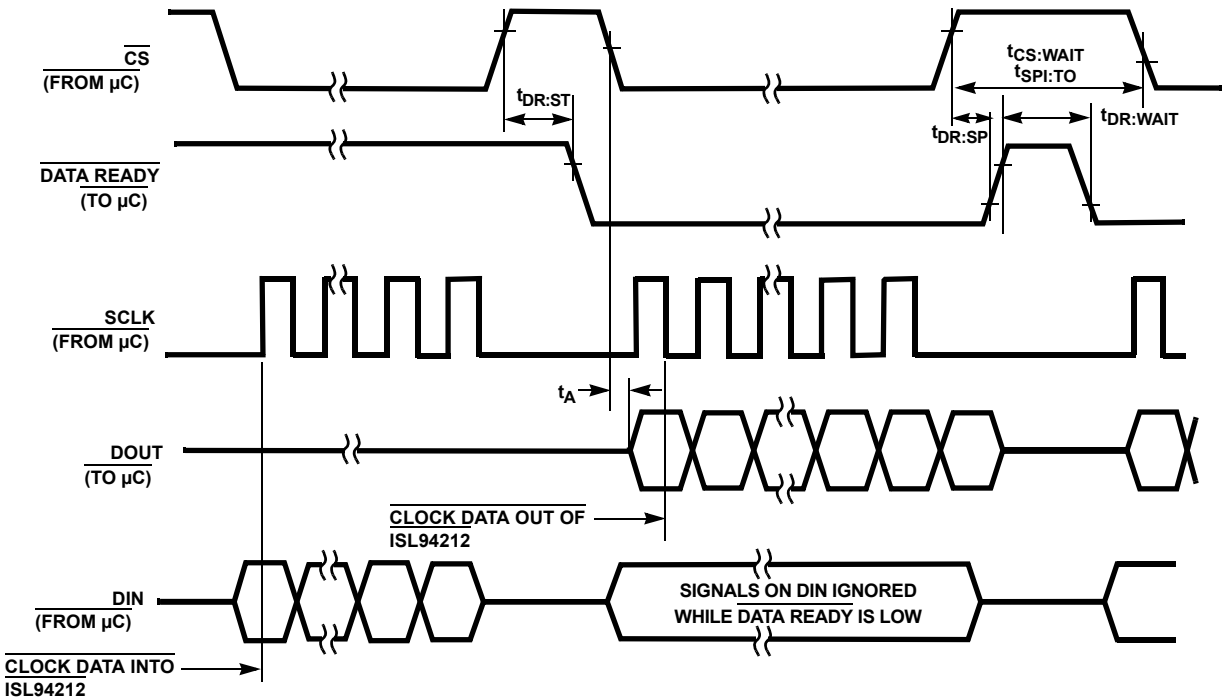

FIGURE 3. SPI HALF DUPLEX (3-WIRE) INTERFACE TIMING

Typical Performance Curves

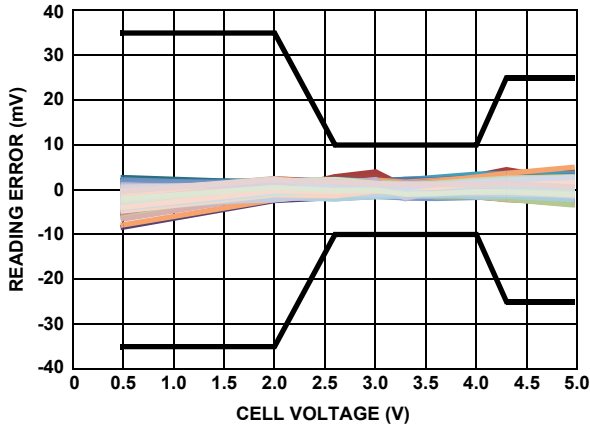

FIGURE 4. CELL VOLTAGE READING ERROR FROM 0°C TO +50°C

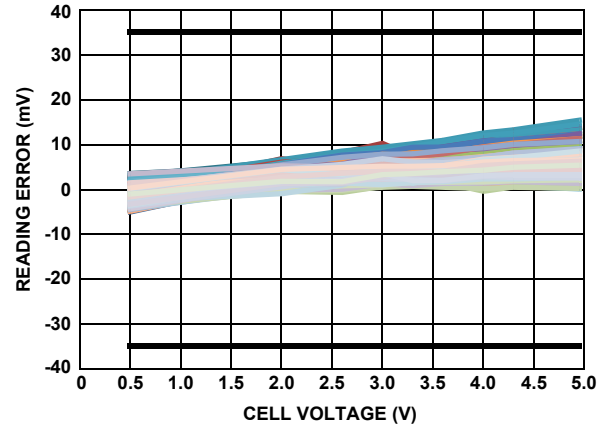

FIGURE 5. CELL VOLTAGE READING ERROR FROM -40°C TO +85°C

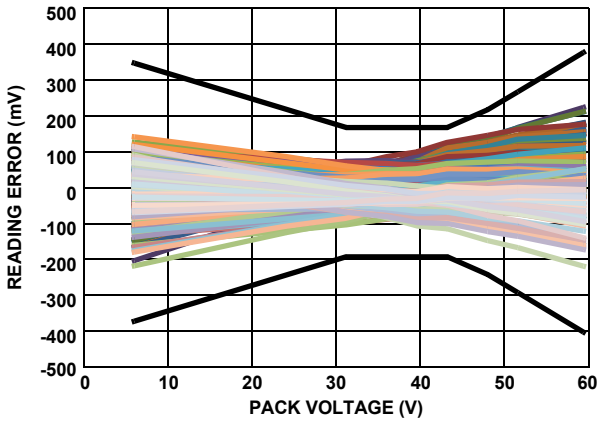

FIGURE 6. PACK VOLTAGE READING ERROR FROM 0°C TO +50°C

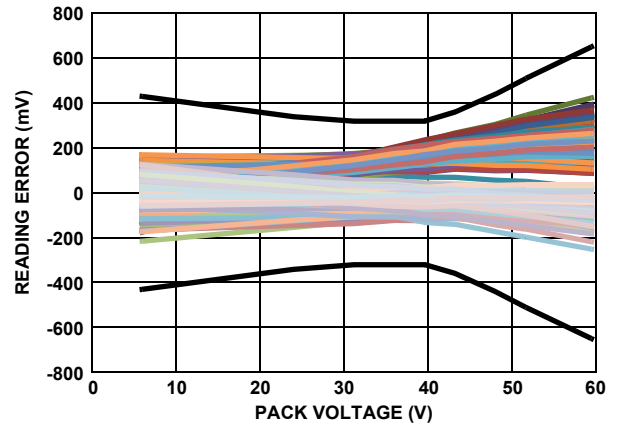

FIGURE 7. PACK VOLTAGE READING ERROR FROM -40°C TO +85°C

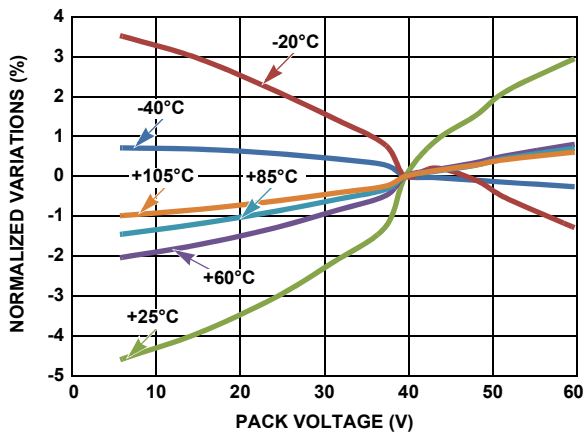

FIGURE 8. IC TEMPERATURE ERROR vs PACK VOLTAGE

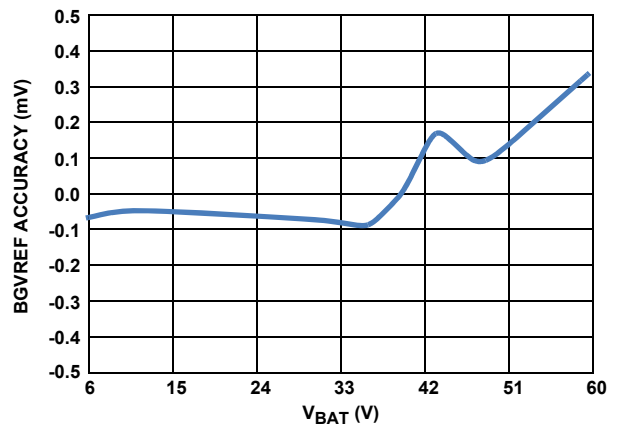

FIGURE 9. VOLTAGE REFERENCE CHECK FUNCTION vs PACK VOLTAGE (AT +25°C)

Typical Performance Curves (Continued)

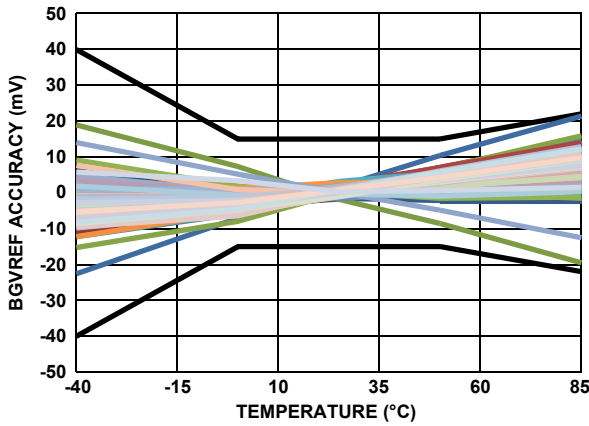

FIGURE 10. VOLTAGE REFERENCE CHECK FUNCTION vs TEMPERATURE ($V_{BAT} = 39.6$)

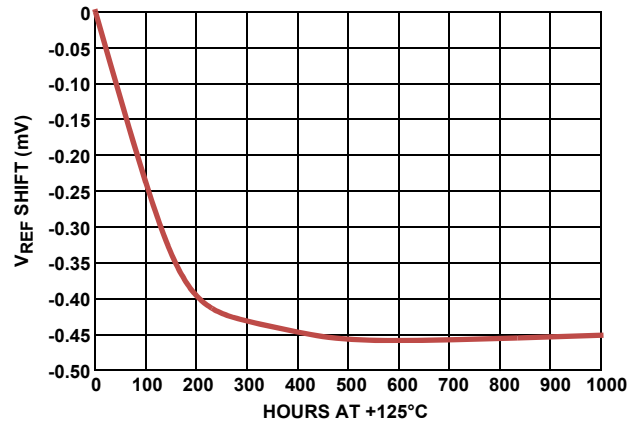

FIGURE 11. V_{REF} SHIFT OVER HTOL

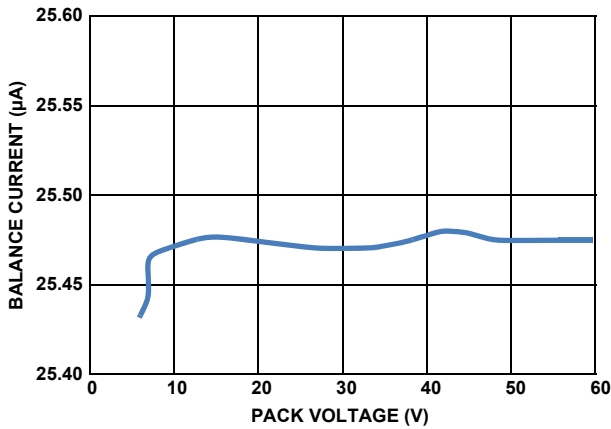

FIGURE 12. BALANCE CURRENT vs PACK VOLTAGE

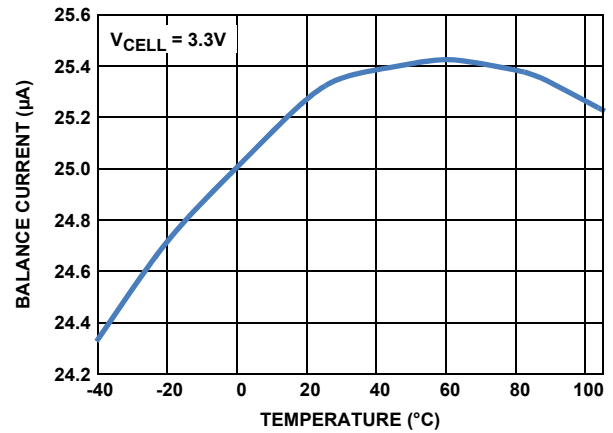

FIGURE 13. BALANCE CURRENT vs TEMPERATURE

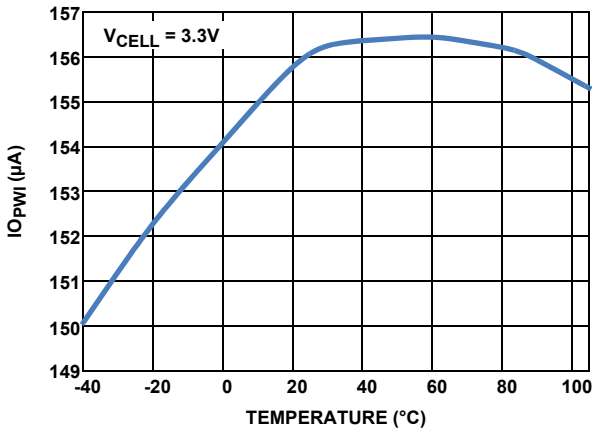

FIGURE 14. OPEN WIRE TEST CURRENT vs TEMPERATURE (150µA SETTING)

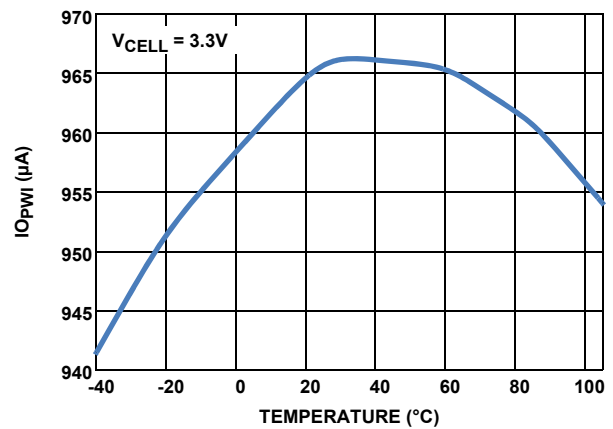

FIGURE 15. OPEN WIRE TEST CURRENT vs TEMPERATURE (1mA SETTING)

Typical Performance Curves (Continued)

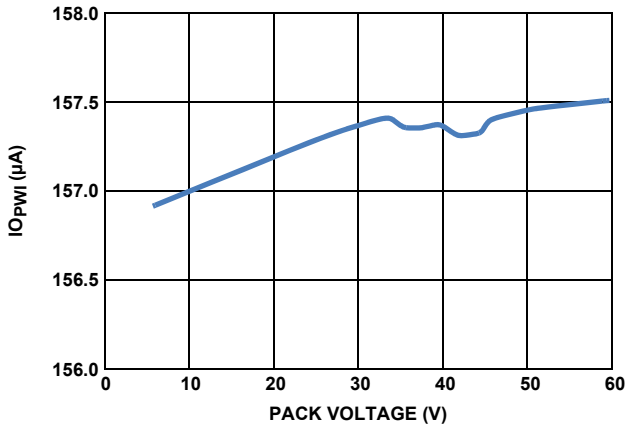

FIGURE 16. OPEN WIRE TEST CURRENT vs PACK VOLTAGE (150µA SETTING)

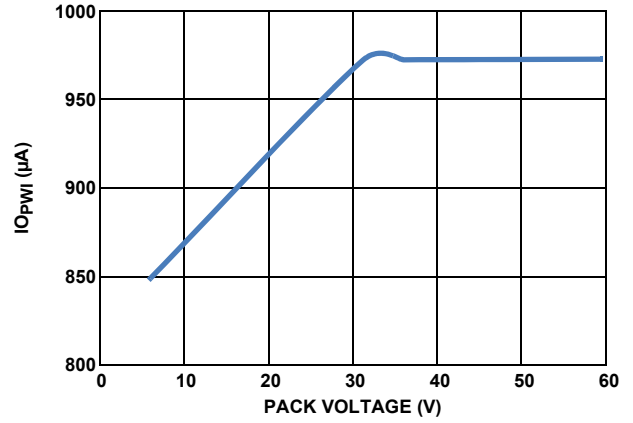

FIGURE 17. OPEN WIRE TEST CURRENT vs PACK VOLTAGE (1mA SETTING)

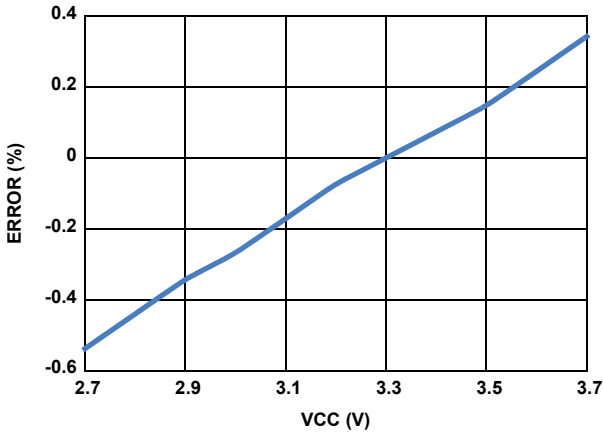

FIGURE 18. 4MHz OSCILLATOR ERROR vs VCC

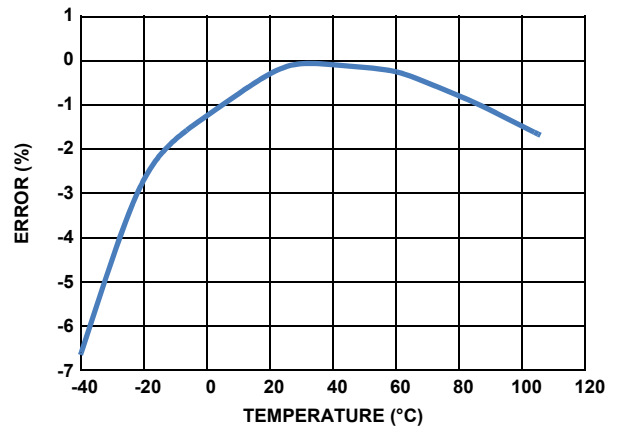

FIGURE 19. 4MHz OSCILLATOR ERROR vs TEMPERATURE

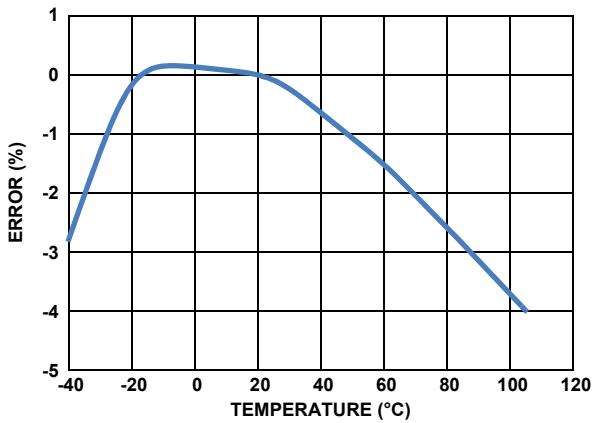

FIGURE 20. 32kHz OSCILLATOR ERROR vs TEMPERATURE

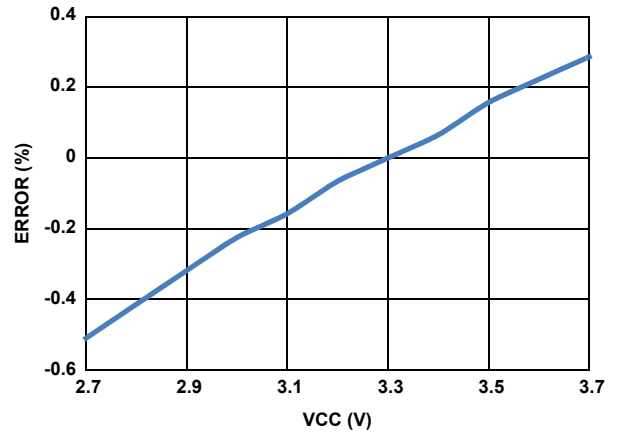

FIGURE 21. 32kHz OSCILLATOR ERROR vs VCC

Typical Performance Curves (Continued)

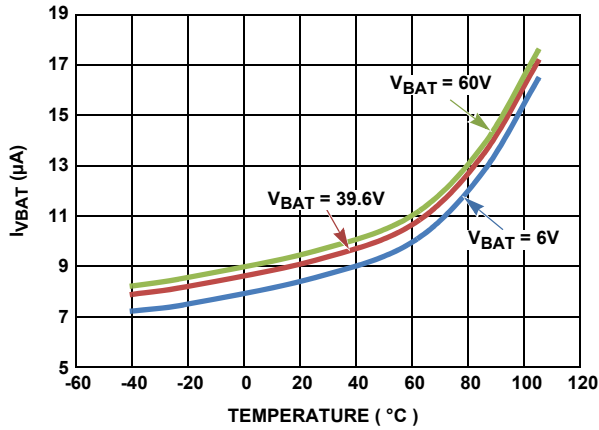

FIGURE 22A. PACK VOLTAGE SLEEP CURRENT vs TEMPERATURE AT 6V, 39.6V, 60V (STANDALONE MODE)

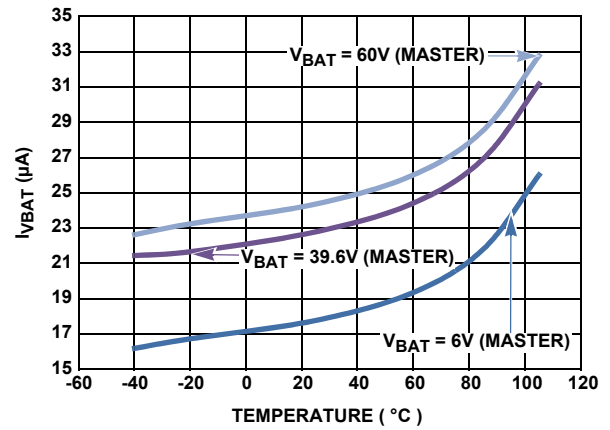

FIGURE 22B. PACK VOLTAGE SLEEP CURRENT vs TEMPERATURE AT 6V, 39.6V, 60V (DAISY CHAIN MODE)

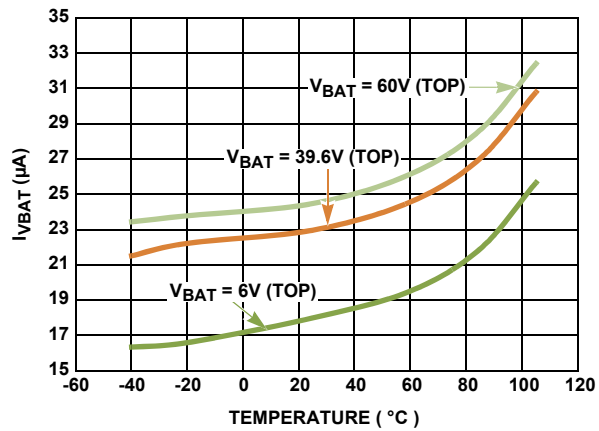

FIGURE 22C. PACK VOLTAGE SLEEP CURRENT vs TEMPERATURE AT 6V, 39.6V, 60V (DAISY CHAIN MODE)

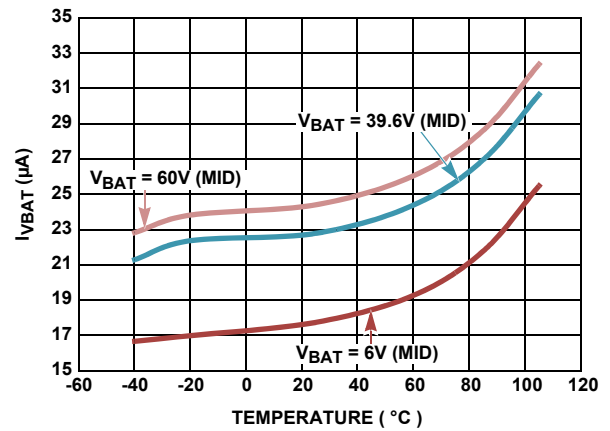

FIGURE 22D. PACK VOLTAGE SLEEP CURRENT vs TEMPERATURE AT 6V, 39.6V, 60V (DAISY CHAIN MODE)

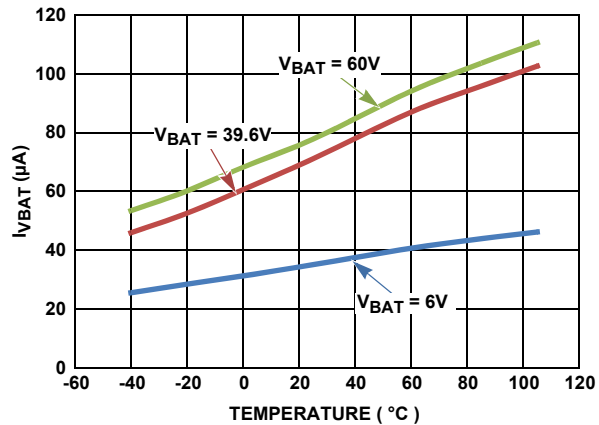

FIGURE 23A. PACK VOLTAGE SUPPLY CURRENT vs TEMPERATURE AT 6V, 39.6V, 60V (STANDALONE MODE)

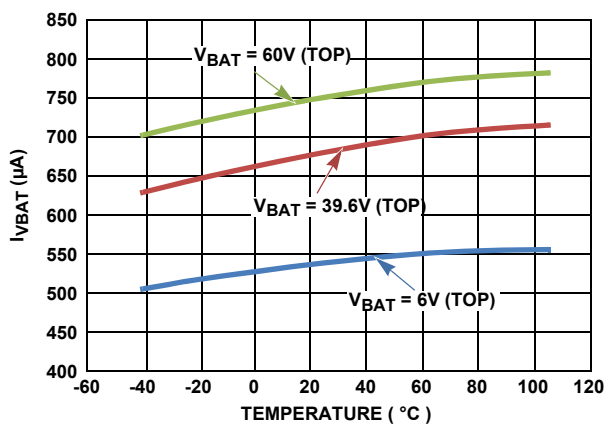

FIGURE 23B. PACK VOLTAGE SUPPLY CURRENT vs TEMPERATURE AT 6V, 39.6V, 60V (DAISY CHAIN TOP)

Typical Performance Curves (Continued)

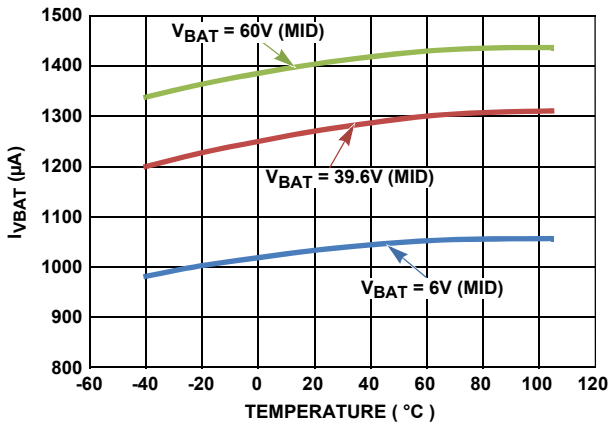

FIGURE 23C. PACK VOLTAGE SUPPLY CURRENT vs TEMPERATURE AT 6V, 39.6V, 60V (DAISY CHAIN MIDDLE)

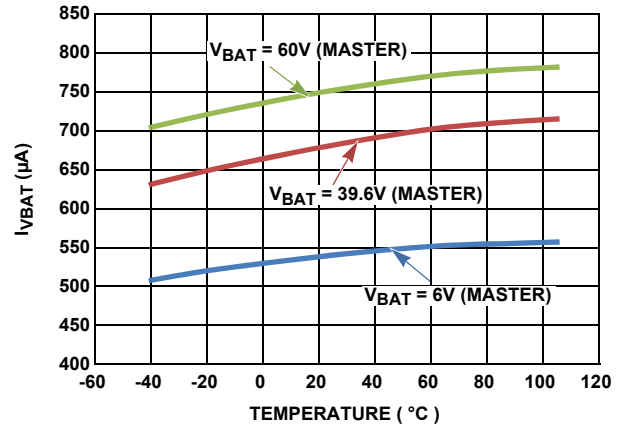

FIGURE 23D. PACK VOLTAGE SUPPLY CURRENT vs TEMPERATURE AT 6V, 39.6V, 60V (DAISY CHAIN MASTER)

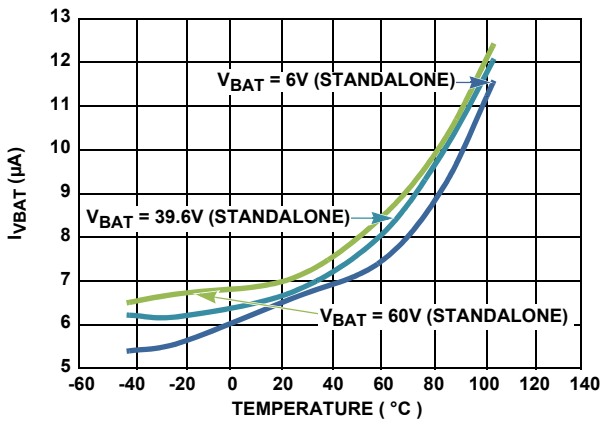

FIGURE 24A. PACK VOLTAGE SHUTDOWN CURRENT vs TEMPERATURE (EN = 0) AT 6V, 39.6V, 60V

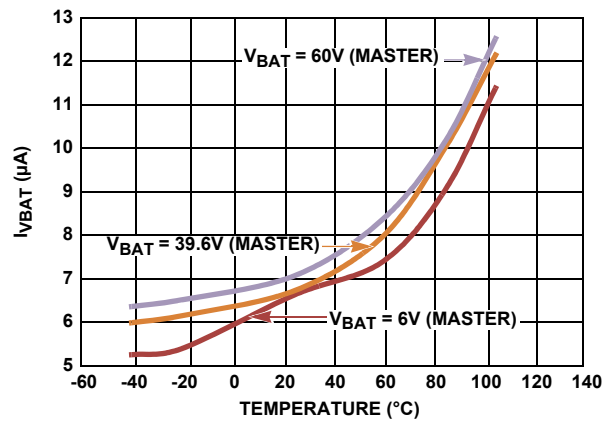

FIGURE 24B. V_{BAT} SHUTDOWN CURRENT vs TEMPERATURE (EN = 0) AT 6V, 39.6V, 60V

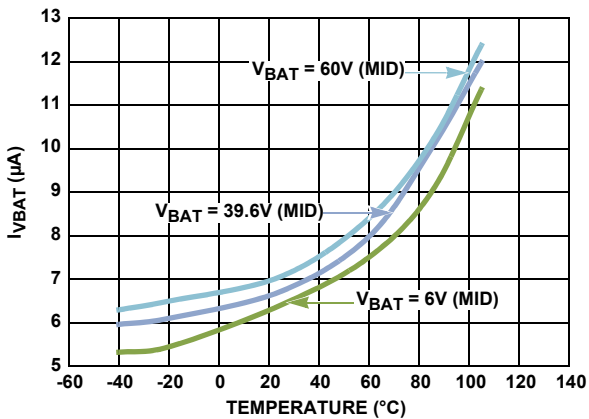

FIGURE 24C. V_{BAT} VOLTAGE SHUTDOWN CURRENT vs TEMPERATURE (EN = 0) AT 6V, 39.6V, 60V

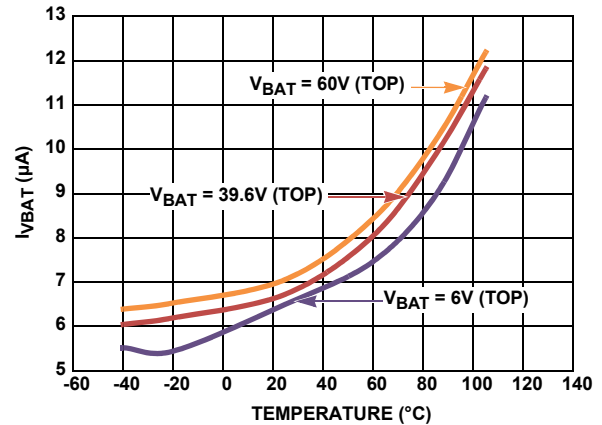

FIGURE 24D. V_{BAT} VOLTAGE SHUTDOWN CURRENT vs TEMPERATURE (EN = 0) AT 6V, 39.6V, 60V

Typical Performance Curves (Continued)

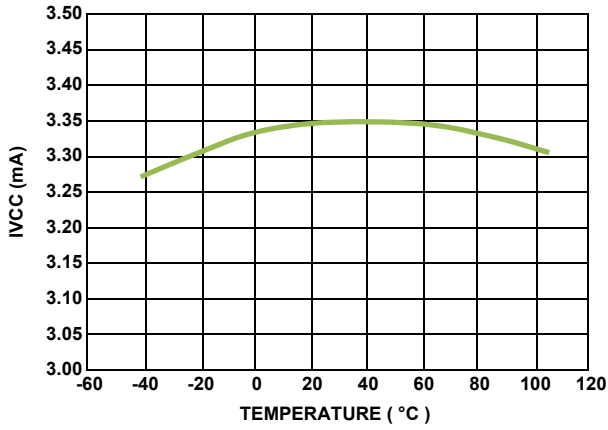

FIGURE 25. VCC SUPPLY CURRENT vs TEMPERATURE AT 6V, 39.6V, 60V

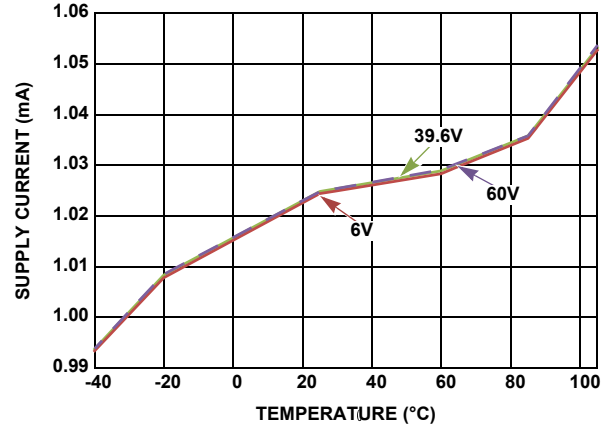

FIGURE 26. V3P3 SUPPLY CURRENT vs TEMPERATURE

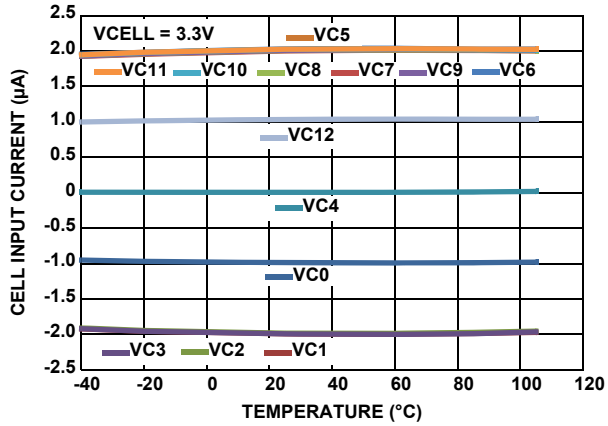

FIGURE 27. CELL INPUT CURRENT vs TEMPERATURE

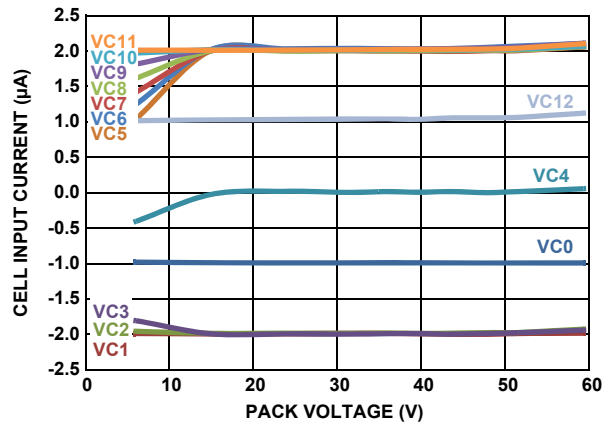

FIGURE 28. CELL INPUT CURRENT vs PACK VOLTAGE (+25°C)

Device Description and Operation

The ISL94212 is a Li-ion battery manager IC that supervises up to 12 series connected cells. Up to 14 ISL94212 devices can be connected in series to support systems with up to 168 cells. The ISL94212 provides accurate monitoring, cell balance control, and diagnostic functions. The ISL94212 includes a voltage reference, 14 bit A/D converter and registers for control and data. An external microcontroller communicates to the ISL94212 through an SPI interface. Series connected ISL94212 devices communicate to each other via a proprietary daisy chain communications interface.

The ISL94212 devices handle daisy chain communications differently depending on their position within the daisy chain. The ISL94212 at one end of the daisy chain acts as a master device for communication purposes. The master device, also called the bottom device, occupies the first position in the daisy chain and communicates to a host microcontroller using an SPI interface. A single daisy chain port then connects the master device to the next device in the daisy chain.

The device at the other end of the daisy chain from the master is the top device. The top device has a single daisy chain port connection to the device below. Devices other than the master and top devices are middle devices. Middle devices have two daisy chain port connections. The up port connects to the device above while the down port connects to the device below. The master ISL94212 device is device number 1. The top device is device number n , where n equals the total number of ISL94212 devices in the daisy chain. The middle devices are numbered 2 to $(n-1)$ with device number 2 being connected to the master device. If $n = 2$, then there is a master device and a top device, with no middle device.

When multiple ISL94212 devices are connected to a series of cells, their power supply domains are normally non-overlapping. The lower (VSS) supply of each ISL94212 nominally connects to the same potential as the upper (V_{BAT}) supply of the ISL94212 device below.

The ISL94212 provides two multiple parameter measurement “scanning” modes in addition to single parameter direct measurement capability. These scanning modes provide pseudo simultaneous measurement of all cell voltages in the stack. In daisy chain applications all measurement data is sent with the corresponding device stack address (the position within the daisy chain), parameter identifier, and data address. In stand alone applications (non-daisy chain) data is sent without additional address information. This maximizes the throughput for full duplex SPI operation. Daisy chain communication throughput is maximized by allowing streamed data (accessed by a “read all data” address).

The addressed device, the top device and the bottom device act as masters for the purposes of communications timing. All other devices are repeaters, passing data up or down the chain.

The only filtering applied to the ADC measurements is that resulting from external protection circuits and the limited bandwidth of the measurement path. No additional filtering is performed within the part. This arrangement is typically needed

to maintain timing integrity between the cell voltage and pack current measurements. The ISL94212 does not measure current. The system performs this separately using other measurement systems. However, the ISL94212 does apply filtering to the fault detection systems.

Power Modes

The ISL94212 has three main power modes: **Normal mode**, **Sleep mode** and **Shutdown mode** (“off”).

Sleep mode is entered in response to a *Sleep* command or after a watchdog timeout. Only the communications input circuits, low speed oscillator and internal registers are active in **Sleep mode**, allowing the part to perform timed scan and balancing activity and to wake up in response to communications.

Drive the enable pin low to place the part in **Shutdown mode**. When entering Shutdown mode, the internal bias for most of the IC is powered down except digital core, sleep mode regulators, and digital input buffers. When exiting, the device powers up and does not reload the factory programmed configuration data from EEPROM.

The **Normal mode** consists of an Active state and a Standby state. In the Standby state, all systems are powered and the device is ready and waiting to perform an operation in response to commands from the host microcontroller. In the Active state, the device performs an operation, such as ADC conversion, open wire detection, etc.

Measurement Modes

The ISL94212 provides three types of measurement modes.

- Scan Once
- Scan Continuous
- Measure

In **Scan Once mode** the part performs the requested scan a single time. In **Scan Continuous mode** the ISL94212 performs repeated scans at intervals controlled by registers settings. **Measure mode** allows a single parameter to be measured.

The ISL94212 ignores a Scan or Measure command, when the device is already in a scan mode or measure mode. But, the command passes through to other devices in the daisy chain. All other communications functions respond normally while the device is scanning or measuring.

Measurement Mode Commands

Measurement modes are activated by commands from an external microcontroller. The ISL94212 uses a memory mapped command structure. Commands are sent to the device using a memory read operation from a specific address. The addresses for the measurement mode commands¹ are shown in [Table 1](#).

There are other commands that perform other actions, but these are discussed in other sections.

1. In this document, the terminology for a hex value (e.g., h0000) is modified by a leading value (e.g., 16') which defines the number of bits. For the measurement mode command address, a value of 6'h02 refers to a binary value of '00 0010'.

TABLE 1. MEASUREMENT MODE COMMAND ADDRESSES

REGISTER ADDRESS	COMMAND SUFFIX	COMMAND
SCAN ONCE		
6'h01	6'h00	Scan Voltages
6'h02	6'h00	Scan Temperatures
6'h03	6'h00	Scan Mixed
6'h04	6'h00	Scan Wires
6'h05	6'h00	Scan All
SCAN CONTINUOUS		
6'h06	6'h00	Scan Continuous
MEASURE		
6'h08	6 bit addr of element to measure	Measure

Scan Once

Five different scan functions are available in single scan (**Scan Once mode**.) Each Scan function is activated by a command from the host microcontroller. The scan functions are:

1. Scan Voltages
2. Scan Temperatures
3. Scan Mixed
4. Scan Wires
5. Scan All

The **Scan Once** functions are synchronous: all addressed stack devices begin scanning immediately following command receipt. There is a scan start latency between subsequent stack devices of one daisy chain clock cycle (e.g., for a stack of 10 devices with a daisy chain operating at 500kHz, the scan start latency between the bottom and top stack devices is approximately 20µs).

Scan Voltages

The **Scan Voltages** command causes the addressed part (or all parts if the common address is used) to scan through the cell voltage inputs followed by the Pack Voltage. IC temperature is also recorded for use with the internal calibration routines. Cell voltages connected to each device are scanned in order from cell-12 (top) to cell-1 (bottom). Cell overvoltage and undervoltage compares are performed on each cell voltage sample. The V_{BAT} and VSS connections are also checked at the end of the scan.

Cell voltage and pack voltage data, along with any fault conditions are stored in local memory ready for reading by the system host microcontroller. If there is a fault condition, the device sets the \overline{FAULT} pin and returns a fault signal (sent down the stack) on completion of a scan. Devices revert to the standby state on completion of the scan activity.

Scan Temperatures

The **Scan Temperatures** command causes the addressed part (or all parts if the common address is used) to scan through the internal and 4 external temperature signals followed by multiplexer loopback and reference measurements. The loopback and reference measurements are part of the internal diagnostics function. Over-temperature compares are performed

on each temperature measurement depending on the condition of the appropriate bit in the *Fault Setup* register.

Temperature data, along with any fault conditions, are stored in local memory ready for reading by the system host microcontroller. If there is a fault condition, the device sets the \overline{FAULT} pin and returns a fault signal (sent down the stack) on completion of a scan. Devices revert to the standby state on completion of the scan activity.

Scan Mixed

The **Scan Mixed** command causes the addressed part (or all parts if the common address is used) to scan through the cell voltage inputs (followed by the pack voltage) with a single external input (ExT1) interposed. IC temperature is also recorded for use with the internal calibration routines. Cell voltages connected to each device are scanned in order from cell-12 (top) to cell-1 (bottom). The external input ExT1 is scanned in the middle of the cell voltages such that half the cells are sampled before ExT1 and half after ExT1. This mode allows ExT1 to be used for an external voltage measurement, such as a current sensing and performs it along with the cell voltage measurements, reducing the latency between measurements. Cell overvoltage and cell undervoltage compares are performed on each cell voltage sample. The V_{BAT} and VSS conditions are also checked at the end of the scan.

The **Scan Mixed** command is intended for use in standalone systems, or by the Master device in stacked applications, and would typically measure a single system parameter, such as battery current. Other stack devices also measure their ExT1 input but these would normally be ignored by the host.

Cell voltage, pack voltage and ExT1 data, along with any fault conditions are stored in local memory ready for reading by the system host microcontroller. Access the data from the ExT1 measurement by a direct *Read ET1 Voltage* command or by the *All Temperatures* read command. If there is a fault condition, the device sets the \overline{FAULT} pin and returns a fault signal (sent down the stack) on completion of a scan. Devices revert to the standby state on completion of the scan activity.

Scan Wires

The **Scan Wires** command causes the addressed part (or all parts if the common address is used) to measure all the VCn pin voltages while applying load currents to each input pin in turn. This is part of the fault detection system.

If there is a fault condition, the device sets the \overline{FAULT} pin and returns a fault signal (sent down the stack) on completion of a scan. No cell voltage data is sent as a result of the *Scan Wires* command. Devices revert to the standby state on completion of this activity.

Scan All

The **Scan All** command incorporates the Scan Voltages, Scan Wires and Scan Temperatures commands and causes the addressed part (or all parts if the common address is used) to execute each of these three scan functions once, in sequence (see [Figure 29 on page 25](#) for example on timing).

Scan Continuous

Scan Continuous mode is used primarily for fault monitoring and incorporates the scan voltages, scan temperatures and scan wires commands.

The **Scan Continuous** command causes the addressed part to set the SCAN bit in the Device Setup register and performs a succession of scans at a predetermined scan rate. Each device operates asynchronously on its own clock. This is similar to the **Scan All** command except that the scans are repeated at intervals determined by the SCN0-3 bits in the Fault Setup register. The Scan Inhibit command is used to stop scanning (i.e., receipt of this command by the target device resets the SCAN bit and stops the scan continuous function).

The ISL94212 provides an option that pauses cell balancing activity while measuring cell voltages in **Scan Continuous mode**. This is controlled by the BDDS bit in the Device Setup register. If BDDS is set, then cell balancing is inhibited during cell voltage measurement and for 10ms before the cell voltages are scanned. Balancing is reenabled at the end of the scan to allow balancing to continue. This function only applies during the scan continuous and the auto balance functions and allows the implementation of a circuit arrangement that can be used to diagnose the condition of external balancing components. It is up to the host microcontroller to manually stop balancing functions (if required) when operating a scan once or measure command.

The **Scan Continuous** scan interval is set using the SCN3:0 bits (lower nibble of the Fault Setup register.) The temperature and wire scans occur at slower rates and depend on the value of the scan interval selected. The scan system is synchronized such that the wire and temperature scans always follow a voltage scan. The three scan sequences, depending on the scans required at a particular instance, are as follows:

- Scan Voltages
- Scan Voltages, Scan Wires
- Scan Voltages, Scan Wires, Scan Temperatures.

The temperature and wire scans occur at 1/5 the voltage scan rate for voltage scan intervals above 128ms. Below this value the temperature scan interval is fixed at 512ms. The behavior of the wire scan interval is determined by the WSCN bit in the Fault Setup register. A bit value of '1' causes the wire scan to be performed at the same rate as the temperature scan. A bit value of '0' causes the wire scan rate to track the voltage scan rate for voltage scan intervals above 512ms while at and below this value the wire scan is performed at a fixed 512ms rate. [Table 2](#) shows the various scan rate combinations available.

Data is not automatically returned while devices are in **Scan Continuous mode** except in the case where a fault condition is detected. The results of voltage and temperature scans are stored in local volatile memory and may be accessed at any time by the system host microcontroller. Devices may be operated in **Scan Continuous mode** while in **Normal mode** or in **Sleep mode**. Devices revert to the **Sleep mode** or remain in **Normal mode**, as applicable on completion of each scan.

The response to a detected fault condition is to send the fault signal, either immediately in the case of standalone devices or daisy chain devices in **Normal mode**, or following transmission of the wakeup signal if the device is being used in a daisy chain configuration and is in **Sleep mode**.

To operate the "Scan Continuous" function in **Sleep mode** the host microcontroller simply configures the ISL94212, starts the **Scan Continuous mode** and then sends the Sleep command. The ISL94212 then wakes itself up each time a scan is required. Note that for the fastest scan settings (scan interval codes 0000, 0001 and 0010) the main measurement functions do not power down between scans, since the ISL94212 remains in **Normal mode**.

TABLE 2. SCAN CONTINUOUS TIMING MODES

SCAN INTERVAL SCN3:0	SCAN INTERVAL (ms)	TEMP SCAN (ms)	WIRE SCAN WSCN = 0 (ms)	WIRE SCAN WSCN = 1 (ms)
0000	16	512	512	512
0001	32	512	512	512
0010	64	512	512	512
0011	128	512	512	512
0100	256	1024	512	1024
0101	512	2048	512	2048
0110	1024	4096	1024	4096
0111	2048	8192	2048	8192
1000	4096	16384	4096	16384
1001	8192	32768	8192	32768
1010	16384	65536	16384	65536
1011	32768	131072	32768	131072
1100	65536	262144	65536	262144

Measure

This command allows a single cell voltage, internal temperature, any of the four external temperature inputs or the secondary voltage reference measurements to be made. The command incorporates a 6-bit suffix that contains the address of the required measurement element. See [Table 3 on page 24](#). The device matching the target address responds by conducting the single measurement and loading the result to local memory. The host microcontroller then reads from the target device to obtain the measurement result. All devices revert to the standby state on completion of this activity.

TABLE 3. MEASURE COMMAND TARGET ELEMENT ADDRESSES

MEASURE COMMAND	MEASURE ELEMENT ADDRESS (SUFFIX)	DESCRIPTION
6'h08	6'h00	V _{BAT} Voltage
	6'h01	Cell 1 Voltage
	6'h02	Cell 2 Voltage
	6'h03	Cell 3 Voltage
	6'h04	Cell 4 Voltage
	6'h05	Cell 5 Voltage
	6'h06	Cell 6 Voltage
	6'h07	Cell 7 Voltage
	6'h08	Cell 8 Voltage
	6'h09	Cell 9 Voltage
	6'h0A	Cell 10 Voltage
	6'h0B	Cell 11 Voltage
	6'h0C	Cell 12 Voltage
	6'h10	Internal temperature reading
	6'h11	External temperature input 1 reading
	6'h12	External temperature input 2 reading
6'h13	External temperature input 3 reading	
6'h14	External temperature input 4 reading	
6'h15	Reference voltage (raw ADC) value. Use to calculate corrected reference value using reference coefficient data. See page 2 data, address 6'h38 – 6'h3A.	

Cell Voltage Measurement Accuracy

The cell voltage monitoring system comprises two basic elements; a level shift to eliminate the cell common mode voltage and an analog-to-digital conversion of the cell voltage.

Each ISL94212 is calibrated at a specific cell input voltage value, V_{NOM}. Cell voltage measurement error data is given in [“MEASUREMENT SPECIFICATIONS” on page 9](#) for various voltage and temperature ranges with voltage ranges defined with respect to V_{NOM}. Plots showing the typical error distribution over the full input range are included in the [“Typical Performance Curves”](#) section beginning on [page 15](#).

Temperature Monitoring

One internal and four external temperature inputs are provided together with a switched bias voltage output (TEMPREG, pin 29). The voltage at the TEMPREG output is nominally equal to the ADC reference voltage such that the external voltage measurements are ratiometric to the ADC reference (see [Figure 61 on page 85](#)).

The temperature inputs are intended for use with external resistor networks using NTC type thermistor sense elements but may also be used as general purpose analog inputs. Each temperature input is applied to the ADC via a multiplexer. The ISL94212 converts the voltage at each input and loads the 14-bit result to the appropriate register.

The TEMPREG output is turned “on” in response to a **Scan temperatures** or **Measure temperature** command. A dwell time of 2.5ms is provided to allow external circuits to settle, after which the ADC measures each external input in turn. The TEMPREG output turns “off” after measurements are completed.

[Figure 29 on page 25](#) shows an example temperature scan with the ISL94212 operating in **scan continuous mode** with a scan interval of 512ms. The preceding voltage and wire scans are shown for comparison.

The external temperature inputs are designed such that an open connection results in the input being pulled up to the full scale input level. This function is provided by a switched 10MΩ pull-up from each input to VCC. This feature is part of the fault detection system and is used to detect open pins.

The internal IC temperature, along with the auxiliary reference voltage and multiplexer loopback signals, are sampled in sequence with the external signals using the scan temperatures command.

The converted value from each temperature input is also compared to the external over-temperature limit and open connection threshold values on condition of the [TST4:1] bits in the Fault Setup register (see [“Fault Setup:” on page 64](#).) If a TSTn bit is set to “1”, then the temperature value is compared to the external temperature threshold and a fault occurs if the measured value is lower than the threshold value. If a TSTn bit is set to “0”, then the temperature measurement is not compared to the threshold value and no fault occurs. The [TST4:1] bits are “0” by default.

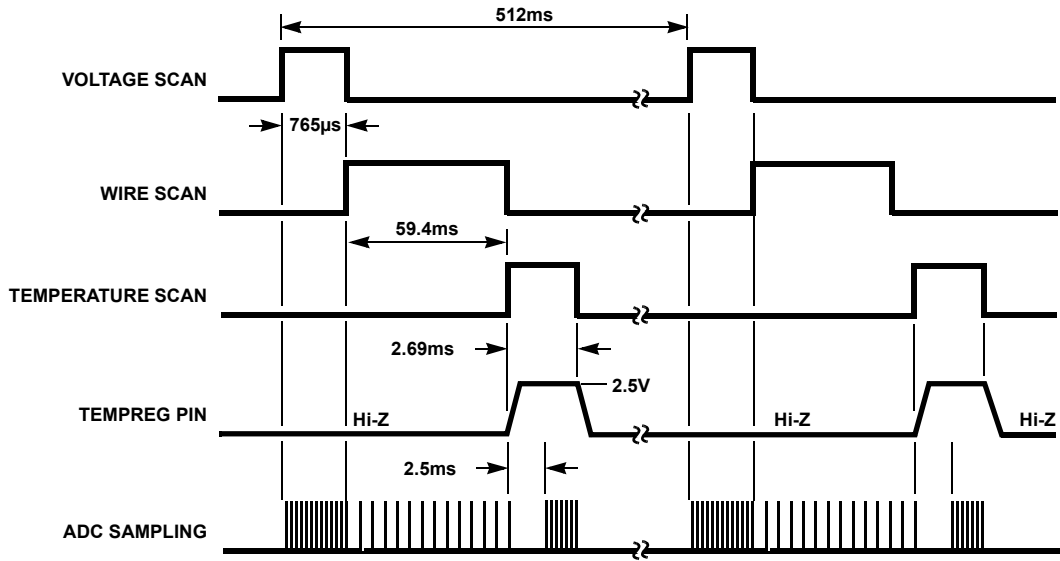

FIGURE 29. SCAN TIMING EXAMPLE DURING SCAN CONTINUOUS MODE AND SCAN ALL MODE

Cell Balancing Functions

Cell balancing is an important function in a battery pack consisting of a stack of multiple Li-ion cells. As the cells charge and discharge, differences in each cell’s ability to take on and give up charge, typically leads to cells with different states of charge. The problem with a stack of cells having different states of charge is that Li-ion cells have a maximum voltage, above which it should not be charged and a minimum voltage, below which it should not be discharged. The extreme case, where one cell in the stack is at the maximum voltage and one cell is at the minimum voltage, results in a nonfunctional battery stack, since the battery stack cannot be charged or discharged.

Cell balancing is performed using external MOSFETs and external current setting resistors (see [Figure 30 on page 30](#)). Each MOSFET is controlled independently by the CB1 to CB12 pins of the ISL94212. The CB1 to CB12 outputs are controlled either directly, or indirectly by an external microcontroller through bits in various control registers.

The balancing functions within the ISL94212 are controlled by multiple registers:

- Balance Setup register (All balance modes, see [Table 4](#))
- Balance Status register (All balance modes, see [Table 7 on page 26](#))
- Device Setup register (auto balance mode only, see [Table 13 on page 30](#))
- Watchdog/Balance Time register (timed and auto balance modes, see [Table 9 on page 27](#))
- Balance Values registers (auto balance only, see example in [Table 11 on page 28](#))

Additional registers are provided for the balance timeout (**Timed mode** and **Auto Balance mode**) and balance value (**Auto Balance mode** only).

Balance Setup Register

TABLE 4. BALANCE SETUP REGISTER (ADDRESS 6’h13)

7	6	5	4	3	2	1	0
BSP2	BSP1	BSP0	BWT2	BWT1	BWT0	BMD1	BMD0
						BEN	BSP3

The Balance Setup register (see [Table 7](#)) contents break down into 4 sub groups.

- Balance wait time: BWT[2:0] bits (also referred to as balance dwell time)
- Balance status pointer: BSP[3:0] bits
- Balance enable: BEN bit
- Balance mode: BMD[1:0] bits

BALANCE WAIT TIME

The balance wait time control bits, BWT[2:0], set the interval between balancing operations in **Auto Balance mode**, as shown in [Table 5](#).

TABLE 5. BALANCE WAIT TIME CONTROL BITS

BWT[2:0]	SECONDS
000	0
001	1
010	2
011	4
100	8
101	16
110	32
111	64

BALANCE STATUS POINTER

See [“Balance Status Register”](#).

BALANCE ENABLE

When all of the other balance control bits are properly set, setting the balance Enable bit to “1” starts the balance operation. The BEN bit can be set by writing directly to the Balance Setup register or by sending a Balance Enable command.

BALANCE MODE

Three methods of cell balance control are provided (see [Table 6](#)).

TABLE 6. BALANCE MODE CONTROL BITS

BMD[1:0]	BALANCE MODE
00	Off
01	Manual
10	Timed
11	Auto

In **Manual mode**, the host microcontroller directly controls the state of each MOSFET output. In **Timed mode**, the host microcontroller programs a balance duration value and selects which cells are to be balanced, then starts the balance operation. The ISL94212 turns all the FETs off when the balance duration has been reached. In **Auto Balance mode**, the host microcontroller programs the ISL94212 to control the balance MOSFETs to remove a programmed “charge delta” value from each cell. The ISL94212 does this by controlling the amount of charge removed from each cell over a number of cycles, rather than trying to balance all cells to a specific voltage.

Balance Status Register

TABLE 7. BALANCE STATUS REGISTER AND BALANCE STATUS POINTER

BSP [3:0]	BALANCE STATUS REGISTER (ADDRESS 6'h14)										
	BAL 12	BAL 11	BAL 10	BAL 9	BAL 8	BAL 7	BAL 6	BAL 5	BAL 4	BAL 3	BAL 2
0000	Reserved for Manual and Timed Balance modes										
0001	Auto balance status register 1										
0010	Auto balance status register 2										
0011	Auto balance status register 3										
0100	Auto balance status register 4										
0101	Auto balance status register 5										
0110	Auto balance status register 6										
0111	Auto balance status register 7										
1000	Auto balance status register 8										
1001	Auto balance status register 9										
1010	Auto balance status register 10										
1011	Auto balance status register 11										
1100	Auto balance status register 12										

The Balance Status register contents control which external balance FET is turned on during a balance event. Each bit in the Balance Status register controls one external balancing FET, such that Bit 0 [BAL1] controls the cell 1 FET and Bit 11 [BAL12] controls the FET for cell 12 (see [Table 7](#).) Bits are set to enable the balancing for that cell and cleared to disable balancing.

The Balance Status register is a “multiple instance” register. There are 13 locations within this register. The Balance Status Pointer BSP[3:0] points to one of these 13 locations in the register (see [Table 7](#)). Only one location in the Balance Status register may be accessed at a time.

The Balance Status register instance at pointer location 0 (BSP[3:0] = 0000) is used for **Manual Balance mode** and **Timed Balance mode**. The Balance Status register instances at pointer locations 1 to 12 (BSP[3:0] = 4'h1 to 4'hC) are used for **Auto Balance mode**. The arrangement is illustrated in [Table 7](#).

In **Auto Balance mode**, the ISL94212 increments the Balance Status pointer on each auto balance cycle to step through Balance Status register locations 1 to 12. This allows the programming of up to twelve different balance profiles for each Auto Balance operation. On each Auto Balance cycle, the Balance Status pointer increments by one. When the operation encounters a zero value at a pointer location, the Auto Balance operation returns to the pattern at location 1 and resumes balancing with that pattern.

More information about the Auto Balance mode is provided in [“Auto Balance Mode” on page 27](#). Example balancing setup information is provided in [“Auto Balance Mode Cell Balancing Example” on page 88](#).

Manual Balance Mode

Select **Manual Balance mode** by setting the balance mode bits BMD[1:0] to 2'b01.

To manually control the cells to be balanced, set the balance status pointer to zero: BSP[3:0] = 4'b0000. Then, program the cells to be balanced by setting bits in the Balance Status register (e.g., to balance cell 5, set the BAL5 bit to 1).

Enable balancing, either by setting the BEN bit in the balance setup register or by sending a balance enable command.

Disable balancing either by resetting the BEN bit or by sending a balance inhibit command.

The balance enable and balance inhibit commands may be used with the “Address All” device address to control all devices in a stack simultaneously.

Balancing is not possible in **Manual Balance mode** while the ISL94212 is in **Sleep mode**. If the watchdog timer is off and the *Sleep* command is received while the device is balancing, then balancing stops immediately and the device goes into the **Sleep mode**.

If the watchdog timer is active during balancing and the device receives the *Sleep* command, then balancing also stops immediately and the device goes into the **Sleep mode**, but the *WDTM* bit is set when the watchdog timer expires. (see [Table 8](#)).

TABLE 8. MANUAL AND TIMED BALANCE MODE WATCHDOG TIMER, BALANCE, SLEEP OPERATION

WATCHDOG TIMER	ACTIONS
Off	Receiving a Sleep command immediately stops balancing and the device enters the Sleep mode .
On	If the device has not received a Sleep command before the watchdog timer expires, then when the watchdog timer does expire, balance stops, the WDTM bit is set and the device enters the Sleep mode .
	Receiving a Sleep command immediately stops balancing and the device enters the Sleep mode . Then, when the watchdog timer expires, the WDTM bit is set.

The watchdog timer function protects the battery from excess discharge due to balancing, in the event that communications is lost while the part is in **Manual Balance mode**. All balancing ceases and the device goes into the **Sleep mode** if the watchdog timeout value is exceeded.

Timed Balance Mode

Select **Timed Balance mode** by setting the balance mode bits BMD[1:0] to 2'b10.

To set up a timed balance operation, set the balance status pointer to zero: BSP[3:0] = 4'b0000. Then program the cells to be balanced by setting bits in the Balance Status register (e.g., to balance cells 7 and 10, set BAL7 and BAL10 bits to 1).

Set the balance on time. The balance on time is programmable in 20 second intervals from 20 seconds to 42.5 minutes using BTM[6:0] bits. These bits are in locations [13:7] of the Watchdog/Balance Time register. See [Tables 9](#) and [10](#) for details.

TABLE 9. WATCHDOG/BALANCE TIME REGISTER (ADDRESS 6'h15)

7	6	5	4	3	2	1	0
		13	12	11	10	9	8
BTM0	WDG6	WDG5	WDG4	WDG3	WDG2	WDG1	WDG0
		BTM6	BTM5	BTM4	BTM3	BTM2	BTM1

TABLE 10. BALANCE CYCLE ON TIME SETTINGS

BTM[6:0]	MINUTES
0000000	Disabled
0000001	0.33
0000010	0.67
0000011	1.00
-	-
1111101	41.67
1111110	42.00
1111111	42.33

Enable balancing, either by setting the BEN bit in the balance setup register or by sending a balance enable command. The selected balance FETs (corresponding to the bits set in balance status register location 4'b0000) turn on when BEN is asserted and turn off when the balance timeout period is met.

Resetting BEN, either directly or by using the balance inhibit command stops the balancing functions and resets the timer values. When BEN is reasserted, or when a new balance enable command is received, balancing resumes, using the full time specified by the BTM[6:0] bits.

When the balance timeout period is met, the End Of Balance (EOB) bit in the Device Setup register is set and BEN is reset.

Balancing is not possible in the **Timed Balance mode** while the ISL94212 is in **Sleep mode**. If the watchdog timer is off and the Sleep command is received while the device is balancing, then balancing stops immediately and the device goes into **Sleep mode**.

If the watchdog timer is active during balance and the device receives the *Sleep* command, then balancing also stops immediately and the device enters **Sleep mode**, but the WDTM bit is set when the watchdog timer expires (see [Table 8](#)).

The watchdog can be disabled at any time by writing the watchdog password (6'h3A) to the watchdog password bits [WP5:0] in the Device Setup register (see [Table 13 on page 30](#)), and then writing 6'h00 to the watchdog timeout bits [WDG5:0] in the Watchdog/Balance time register (see [Table 9](#)).

Auto Balance Mode

Auto Balance mode provides the capability to perform balancing autonomously and in an intelligent manner. Thermal issues are accommodated by the provision of the multiple instance Balance Status register and a balance wait time. Cells are balanced with periodic measurements being performed at the balance cycle on time interval (see [Table 10](#)). These measurements are used to calculate the reduction in State of Charge (SOC) with each balancing cycle and to terminate balancing of a particular cell when the total SOC change target has been reached.

Select Auto Balance mode by setting the balance mode bits BMD[1:0] to 2'b11.

In **Auto Balance mode**, the ISL94212 cycles through each balance status register instance and turns on the balancing outputs corresponding to the bits set in each balance status register instance.

AUTO BALANCE SEQUENCE

The Auto Balance sequence is programmed using the “multiple instance” Balance Status register and the balance status pointer bits.

The first cycle of the auto balance operation begins with the balance status pointer at location 1, specifying the first Balance Status register instance. For the next auto balance cycle, the balance status pointer increments to location 2. For each subsequent cycle, the pointer increments to the next Balance Status register instance, until a zero value instance is encountered. At this point the sequence repeats from the

balance status register instance at the balance status pointer location 1 until all the cells have met their SOC adjustment value.

For example, to balance odd numbered cells during the first cycle and even numbered cells on the second cycle: (see example in [“Cell Balancing – Auto Mode” on page 88.](#))

- First set the balance status pointer to 1:
BSP[3:0] = 0001.
- Specify the even bits by setting *Balance Status* register bits 0, 2, 4, 6, 8 and 10 to “1”.
Balance Status register = 14’h0555
- Set the balance status pointer to 2:
BSP[3:0] = 0010.
- Specify the odd bits by setting *Balance Status* register bits 1, 3, 5, 7, 9 and 11 to “1”.
Balance Status register = 14’h0AAA
- Set the balance status pointer to 3:
BSP[3:0] = 0011.
- Specify sequence termination by resetting all the bits in the *Balance Status* register to zero. The next cycle will go back to balance status pointer = 1.
Balance Status register = 14’h0000.
- Leave the balance status pointer to 3:
BSP[3:0] = 0011.

AUTO BALANCE TIMING

Set the desired interval between balancing cycles using the balance wait time bits BWT[2:0] (locations [4:2] of the Balance Setup register), see [Table 4 on page 25](#) and [Table 5 on page 25](#).

Set the balance cycle on time using the BTM[6:0] bits (locations [13:7] of the Watchdog/Balance Time register), see [Tables 9 and 10 on page 27](#).

Set or clear the BDDS bit, Bit 7 in the Device Setup register, as required. If BDDS is set, then cell balancing is turned off 10ms before the cell voltage scan at the end of each balance cycle. If BDDS is cleared, then balance functions remain “on” during Auto Balance mode cell scan measurements. BDDS must be set in Auto Balance mode when using the standard battery connection configuration shown in [Figure 50 on page 73](#).

AUTO BALANCE (DELTA SOC) VALUE

The next step in setting up an Auto Balance operation is to program the balance value for each cell. The balance value (delta SOC) is the difference between the present charge in a cell and the desired charge for that cell.

The method for calculating the state of charge for a cell is left to the system designer. Typically, determining the state of charge is dependent on the chosen cell type and manufacturer, is dependent on cell voltage, charge and discharge rates, temperature, age of the cell, number of cycles, and other factors. Tables for determining SOC are often available from the battery cell manufacturer.

The balance value itself is a function of the current SOC, required SOC, balancing leg impedance, and sample interval. This value is calculated by the host microcontroller for each cell. The balancing leg impedance is made up of the external balance FET

and balancing resistor. The sample interval is equal to the balance cycle on time period (e.g., each cell voltage is sampled at the end of the balance on time).

The balancing value B for each cell is calculated using the formula shown in [Equation 1](#). (See also [“Balance Value Calculation Example” on page 88](#)):

$$B = \frac{8191}{5} \times (\text{CurrentSOC} - \text{TargetSOC}) \times \frac{Z}{dt} \tag{EQ. 1}$$

Where:

- B = the balance register value
- CurrentSOC = the present SOC of the cell (Coulombs)
- TargetSOC = the required SOC value (Coulombs)
- Z = the balancing leg impedance (ohms)
- dt = the sampling time interval
(Balance cycle on time in seconds)
- 8191/5 = a voltage to Hex conversion value

The balancing leg impedance is normally the sum of the balance FET $r_{DS(ON)}$ and the balance resistor.

The balancing value (B) can also be defined as in the set of equations following. Auto balance is guided by [Equations 2 and 3](#):

$$\text{SOC} = I \times t = \frac{V}{Z} \times t \tag{EQ. 2}$$

$$B = \text{SOC} \times \frac{Z}{dt} = \frac{V}{Z} \times t \times \frac{Z}{dt} = \frac{V}{dt} \times t \tag{EQ. 3}$$

Where:

- dt = Balance cycle on time
- t = Total balance time

Looking at [Equations 2 and 3](#), the impedance drops out of the equation, leaving only voltage and time elements. Thus, “B” becomes a collection of voltages that integrate during the balance cycle on time, and accumulate over the total balance time period, to equal the programmed delta capacity.

Twelve 28-bit registers are provided for the balance value for each cell. The balance values are programmed for all cells as needed using Balance Value registers 6’h20 to 6’h37 (see [Table 11](#) for the contents of the CELL1 Balance Values Register).

TABLE 11. BALANCE VALUES REGISTER CELL1 (ADDRESS 6’h20, 6’h21)

	7 15	6 14	5 13	4 12	3 11	2 10	1 9	0 8
6’20	B0107	B0106	B0105	B0104	B0103	B0102	B0101	B0100
			B0113	B0112	B0111	B0110	B0109	B0108
6’21	B0121	B0120	B0119	B0118	B0117	B0116	B0115	B0114
			B0127	B0126	B0125	B0124	B0123	B0122

At the end of each balance cycle on time interval the ISL94212 measures the voltage on each of the cells that were balanced during that interval. The measured values are then subtracted from the balance values for those cells. This process continues until the balance value for each cell is zero, at which time the auto balancing process is complete.

AUTO BALANCE OPERATION

Once all of the cell balance FET controls, the balance values and the timers are set up, balance is enabled either by setting the BEN bit in the Balance Setup register or by sending a balance enable command.

Once enabled, the ISL94212 cycles through each instance of the Balance Status register for the duration given by the balance timeout. Between each balance status register instance, the device does a scan all operation and inserts a delay equal to the balance wait time. The process continues with the balance status pointer wrapping back to 1 until all the balance value registers equal zero. If one cell balance value register reaches zero before the others, balancing for that cell stops, but the others continue.

Resetting BEN, either directly or by using the Balance Inhibit command, stops the balancing functions but maintains the current Balance Value register contents. Auto balancing continues from the balance status register location 1 when BEN is reasserted.

When auto balancing is complete, the End of balance (EOB) bit in the Device Setup register is set and BEN bit is reset.

Balancing is not possible using the **Auto Balance Mode** while the ISL94212 is in **Sleep mode**. If the sleep command is received while the device is balancing (and the watchdog timer is off) then balancing continues until it is finished and device enters **Sleep mode**. If the watchdog timer is active during the **Auto Balance mode** and the device receives the sleep command, then balancing immediately stops and device enters **Sleep mode**. The WDTM bit is set when the watchdog timer expires (see [Table 12](#)).

TABLE 12. AUTO BALANCE MODE WATCHDOG TIMER, BALANCE, SLEEP OPERATION

WATCHDOG TIMER	ACTIONS
Off	Receiving a Sleep command puts the device into Sleep mode when the auto balance operation is finished.
On	<p>If the device has not received a Sleep command, then when the watchdog timer expires, balance stops, the WDTM bit is set and the device enters Sleep mode.</p> <p>When the device receives a Sleep command, balance stops immediately. When the watchdog timer expires, the WDTM bit is set and the device enters Sleep mode.</p>

The watchdog can be disabled at any time by writing the watchdog password (6'h3A) to the watchdog password bits [WP5:0] in the Device Setup register (see [Table 13 on page 30](#)) and then writing 6'h00 to the watchdog timeout bits [WDG5:0] in the Watchdog/Balance Time register (see [Table 9 on page 27](#)).

Balance FET Drivers

External balancing FETs are controlled by current sources or current sinks attached to the cell balancing (CB) pins. The gate voltage on each FET is then controlled by a locally placed gate-to-source resistor. Voltage clamps are included at each CB output to limit the maximum gate drive voltage. Series gate resistors are used to protect both the external FET and internal IC circuits from external voltage transient effects. An internal gate-to-source connected resistor is used to provide a redundant gate discharge path.

A mix of N-channel and P-channel devices are used for the external FETs in order to remove the need for a charge pump. Cell 12, Cell 11 and Cell 10 balance positions use P-channel devices. The remaining positions use N-channel devices. The basic balance FET drive arrangement is shown in [Figure 30](#).

Additional circuit guidelines are provided in the [“Typical Applications Circuits” on page 72](#).

Reduced cell counts for fewer than 12 cells are accommodated by removing connections to the cells in the middle of the stack first. The top and bottom cell locations are always occupied. See [“Operating the ISL94212 with Reduced Cell Counts” on page 78](#) for suggested cell configurations when using fewer than 12 cells.

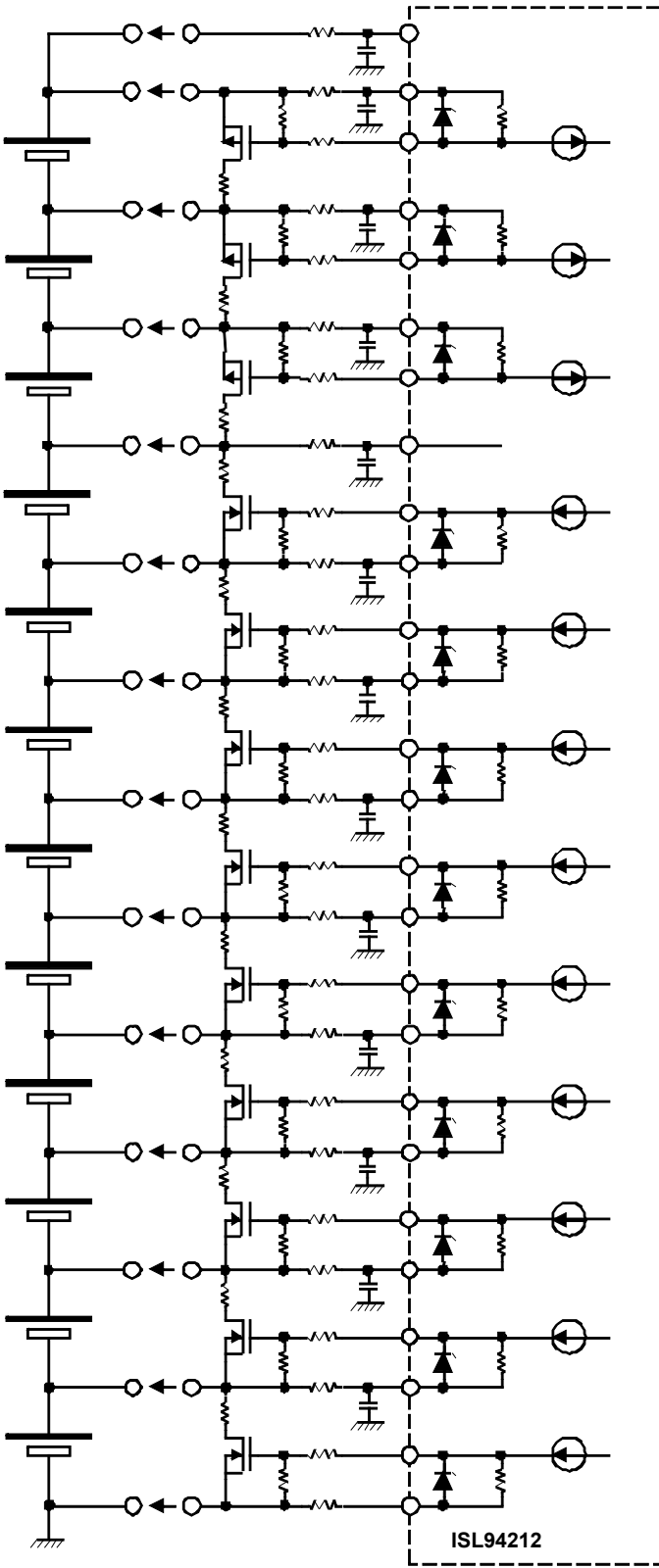

FIGURE 30. EXTERNAL FET DRIVING CIRCUITS

Device Setup Register

TABLE 13. DEVICE SETUP REGISTER (ADDRESS 6'h19)

7	6	5 13	4 12	3 11	2 10	1 9	0 8
BDDS		ISCN	SCAN	EOB		PIN37	PIN39
		WP5	WP4	WP3	WP2	WP1	WP0

BDDS

A function is provided to allow any cell balancing activity to be paused while measuring cell voltages in scan continuous mode and auto balance mode. This is controlled by the BDDS bit in the Device Setup register (address 6'h19) (see Table 13). If BDDS is set, then cell balancing is inhibited during cell voltage measurement and for 10ms before the cell voltage scan. Balancing is reenabled at the end of the scan. This function only applies during the scan continuous mode and the auto balance mode. It is up to the host microcontroller to manually stop balancing functions (if required) before sending a scan or measure command.

WATCHDOG PASSWORD

Before writing a zero to the watchdog timer, which turns off the timer, it is necessary to write a password to the [WP5:0] bits. The password value is 6'h3A.

EOB

This End of balance bit indicates that a **Timed Balance mode** or an **Auto Balance mode** has completed.

SCAN

This bit is set in response to a Scan Continuous command and cleared by the Scan Inhibit command.

ISCN, PIN37, PIN39

The ISCN bit is used in the Open Wire scan. PIN37 and PIN39 bits show the state of the respective device pins.

Cell Balance Enabled Register

TABLE 14. CELLS BEING BALANCED REGISTER (ADDRESS 6'h3B)

7	6	5 13	4 12	3 11	2 10	1 9	0 8
CBEN	CBEN	CBEN	CBEN	CBEN	CBEN	CBEN	CBEN
8	7	6	5	4	3	2	1
				CBEN	CBEN	CBEN	CBEN
				12	11	10	9

To facilitate the system monitoring of the cell balance operation, the ISL94212 has a register that shows the present state of the balance drivers. Table 14 shows the Cells Being Balanced register, located on Page 2 at address 6'h3B. If the bit is "1" it indicates that the CBn output is enabled. A "0" indicates that the CBn output is disabled.

System Configuration

The ISL94212 provides two communications systems. An SPI synchronous port is provided for communication between a microcontroller and the ISL94212. For standalone (non-daisy chain) systems, the SPI port is the only port needed. In systems where there is more than one ISL94212, daisy chain (asynchronous) ports provide communication between the SPI port on the Master and other ISL94212 devices.

The communications setup is controlled by the COMMS SELECT 1 and COMMS SELECT 2 pins on each device. These pins specify whether the ISL94212 is a standalone device, the daisy chain master, the daisy chain top, or a middle position in the daisy chain. See Figures 31 and 32 and Table 15. This configuration also specifies the use of SPI or daisy chain on the communication ports.

TABLE 15. COMMUNICATIONS MODE CONTROL

COMMS SELECT 1	COMMS SELECT 2	PORT 1 COMM	PORT 2 COMM	COMMUNICATIONS CONFIGURATION
0	0	SPI (Full Duplex)	Disabled	Standalone
0	1	SPI (Half Duplex)	Enabled	Daisy Chain, Master device setting
1	0	Daisy Chain	Disabled	Daisy Chain, Top device setting
1	1	Daisy Chain	Enabled	Daisy Chain Middle device setting

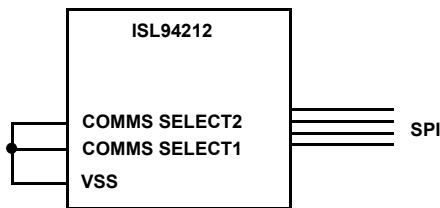

FIGURE 31. NON-DAISY CHAIN COMMUNICATIONS CONNECTIONS AND SELECT

All communications are conducted through the SPI port in single 8-bit byte increments. The MSB is transmitted first and the LSB is transmitted last.

Commands in non-daisy chain systems are composed of a read/write bit, page address (3 bits), data address (6 bits) and data (6 bits). Commands in daisy chain systems are composed of a device address (4 bits), a read/write bit, page address (3 bits), data address (6 bits), data (6 bits), and CRC (4 bits).

Commands and data are memory mapped to 14-bit data locations. The memory map is arranged in pages. Pages 1 and 2 are used for volatile data. Page 3 contains the action and communications administration commands. Page 4 accesses non-volatile memory. Page 5 is used for factory test.

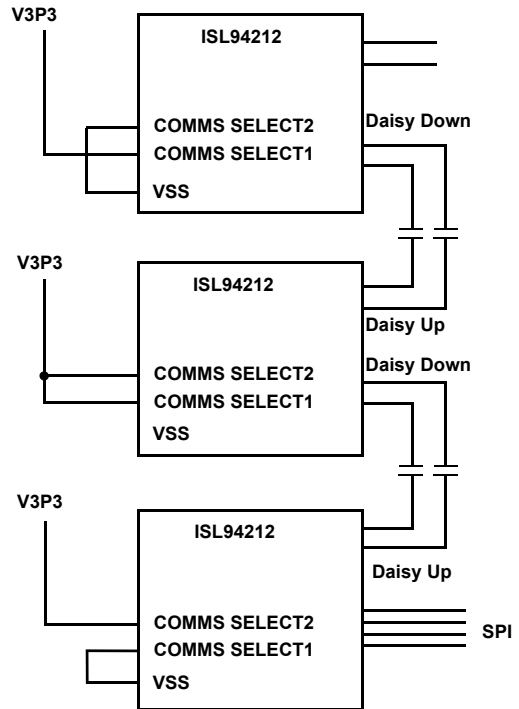

FIGURE 32. DAISY CHAIN COMMUNICATIONS CONNECTIONS AND SELECTION

SPI Interface

The ISL94212 operates as a SPI slave capable of bus speeds up to 2Mbps. Four lines make up the SPI interface: SCLK, DIN, DOUT and \overline{CS} . The SPI interface operates in either full duplex or half duplex mode depending on the daisy chain status of the part.

The DOUT line is normally tri-stated (high impedance) to allow use in a multidrop bus. DOUT is only active when \overline{CS} is low.

Full Duplex Operation

In non-daisy chain applications, the SPI bus operates as a standard, full duplex, SPI port. Read and write commands are sent to the ISL94212 in 8-bit blocks. \overline{CS} is taken high between each block. Data flow is controlled by interpreting the first bit of each transaction and counting the requisite number of bytes. It is the host microcontroller's responsibility to ensure that commands are correctly formulated as an incorrect formulation, (e.g., read bit instead of write bit), would cause the port to lose synchronization. There is a timeout period associated with the \overline{CS} inactive (high) condition, which resets all the communications counters. This effectively resets the SPI port to a known starting condition. If \overline{CS} stays high for more than 100µs then the SPI state machine resets.

The ISL94212 responds to read commands by loading the requested data to its output buffer. The output buffer contents are then loaded to the shift register when \overline{CS} goes low and are shifted out on the DOUT line on the falling edges of SCLK. This sequence continues until all the requested data has been sent. All single register read commands and responses are 2-bytes long. All bytes are handled in pairs during device reads. Device writes are 3-bytes long.

A pending device response from a previous command is sent by the ISL94212 during the first 2 bytes of the 3-byte Write transaction. The third byte from the ISL94212 is then discarded by the host microcontroller. This maintains sequencing during 3-byte (Write) transactions.

Half Duplex Operation

The SPI operates in half duplex mode in Daisy Chain applications (see [Table 15 on page 31](#)). Data flow is controlled by a handshake system using the $\overline{\text{DATA READY}}$ and $\overline{\text{CS}}$ signals. $\overline{\text{DATA READY}}$ is controlled by the ISL94212. $\overline{\text{CS}}$ is controlled by the host microcontroller. This handshake accommodates the delay between command receipt and device response due to the latency of the daisy chain communications system.

Responses from stack devices are received by the stack Master (stack bottom device). The stack Master then asserts its $\overline{\text{DATA READY}}$ output once the first full data byte is available. The host microcontroller responds by asserting $\overline{\text{CS}}$ and clocking the data out of the *DOUT* port. The $\overline{\text{DATA READY}}$ line is then cleared and *DOUT* is tri-stated in response to $\overline{\text{CS}}$ being taken high. In this mode the *DIN* and *DOUT* lines may be connected externally.

Half duplex communications are conducted using the $\overline{\text{DATA READY}}$ / $\overline{\text{CS}}$ handshake as follows:

1. The host microcontroller sends a command to the ISL94212 using the $\overline{\text{CS}}$ line to select the ISL94212 and clocking data into the ISL94212 *DIN* pin.
2. The ISL94212 asserts $\overline{\text{DATA READY}}$ low when it is ready to send data to the host microcontroller. When $\overline{\text{DATA READY}}$ is low, the ISL94212 is in transmit mode and will ignore any data on *DIN*.

3. The host microcontroller asserts $\overline{\text{CS}}$ low and clocks 8 bits of data out of *DOUT* using *SCLK*.
4. The host microcontroller then raises $\overline{\text{CS}}$. The ISL94212 responds by raising $\overline{\text{DATA READY}}$ and tri-stating *DOUT*.
5. The ISL94212 reasserts $\overline{\text{DATA READY}}$ for the next byte and so on.

The host microcontroller must service the ISL94212 if $\overline{\text{DATA READY}}$ is low before sending further commands. Any data sent to *DIN* while $\overline{\text{DATA READY}}$ is low is ignored by the ISL94212.

A 4 byte data buffer is provided for SPI communications. This accommodates all single transaction responses. Multiple responses, such as those that may be produced by a device detecting an error would overflow this buffer. It is important therefore that the host microcontroller reads the first byte of data before a 5th byte arrives on the Master device's daisy chain port so as not to risk losing data.

The $\overline{\text{DATA READY}}$ output from the ISL94212 is not asserted if $\overline{\text{CS}}$ is already asserted. It is possible for the microcontroller to interrupt a sequential data transfer by asserting $\overline{\text{CS}}$ before the ISL94212 asserts $\overline{\text{DATA READY}}$. This causes a conflict with the communications and is not recommended. A conflict created in this manner would be recognized by the microcontroller either not receiving the expected response or receiving a communications failure notification.

Interface timing for full and half duplex SPI transfers are shown in [Figures 2 and 3 on page 14](#).

Examples of full duplex SPI read and write sequences are shown in [Figures 33 and 34](#).

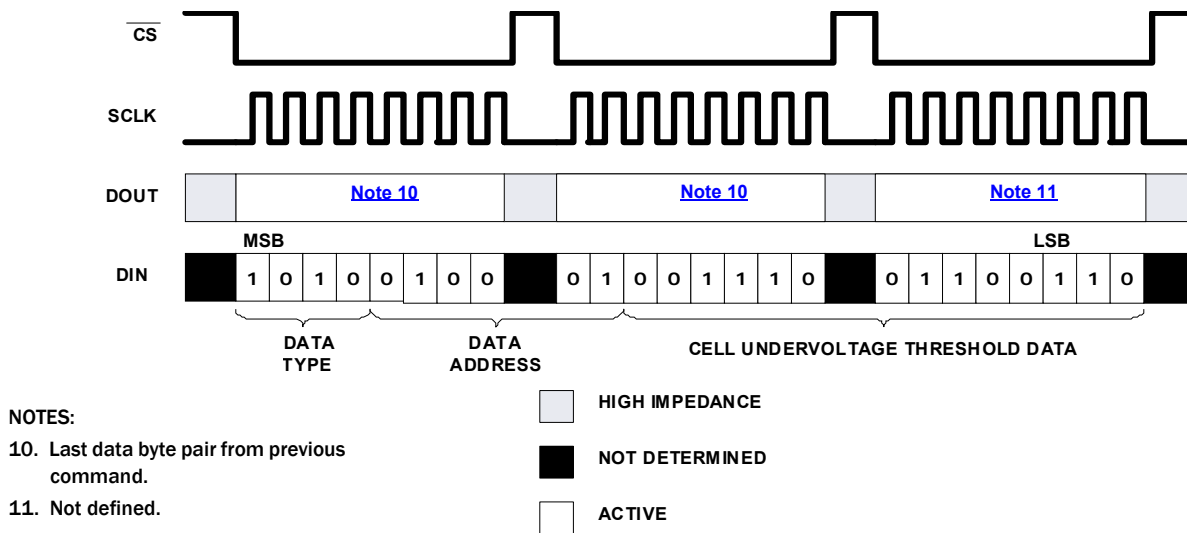

FIGURE 33. SPI WRITE EXAMPLE: WRITE UNDERVOLTAGE THRESHOLD DATA

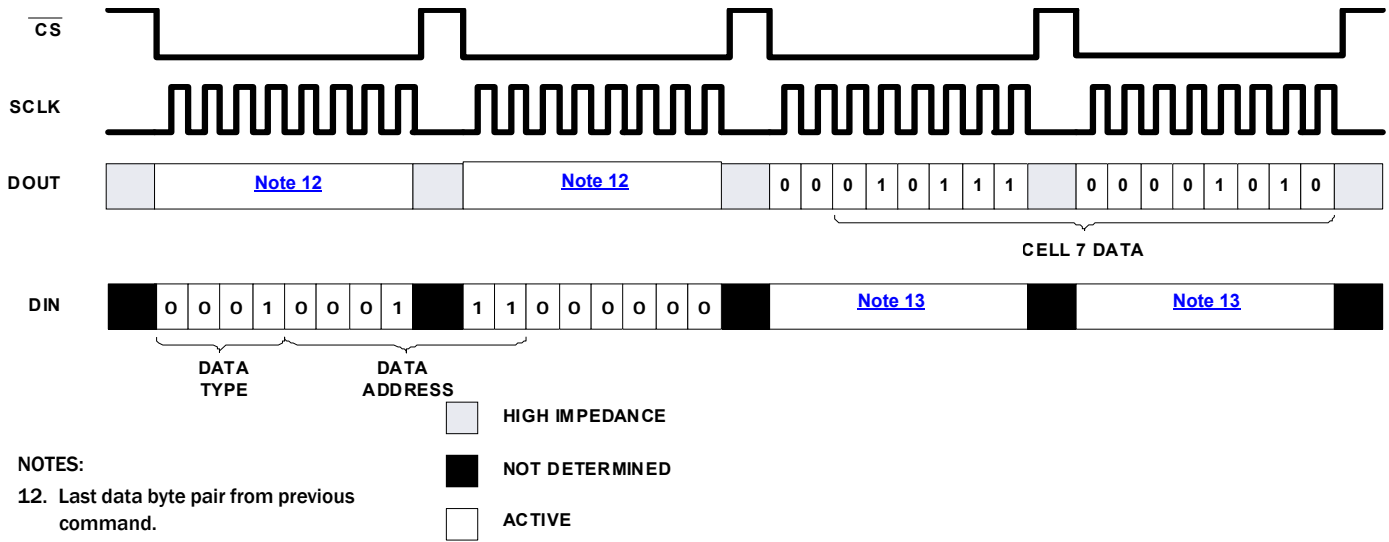

FIGURE 34. SPI READ EXAMPLE: READ CELL 7 DATA

NOTES:

- 12. Last data byte pair from previous command.
- 13. Next command (or 8'h00 if no command).

Non-daisy Chain Systems

In non-daisy chain (standalone) systems, all communications sent from the master are 2 or 3 bytes in length. Data read and action commands are 2 bytes. Data writes are 3 bytes. Device responses are 2 bytes in length and contain data only.

Commands are composed of a $\overline{\text{read/write}}$ bit, page (3 bits), data address (6 bits) and data (6 bits).

Action commands, such as scan and communications administration commands are treated as reads.

Non-daisy chain communications are conducted without CRC (Cyclical Redundancy Check) error detection.

The rules for non-daisy chain installations are shown in [Table 16](#).

TABLE 16. ISL94212 DATA INTERPRETATION RULES FOR NON-DAISY CHAIN INSTALLATIONS

FIRST BIT IN SEQUENCE	PAGE	DATA ADDRESS	INTERPRETATION
0	011	001000	Measure command. Last six bits of transmission contain element address.
0	Any	All other	Device read or action command. Last six bits of transmission are zero.
1	Any	Any	Device write command.

Normal Communications

Non-daisy chain devices do not generate a response to write or system level commands. Data integrity may be verified by reading register contents after writing. The ISL94212 does nothing in response to a write or administration command that is not recognized. An unrecognized read command returns 16'h0000. An incomplete command, such as may occur if communications are interrupted, is registered as an unrecognized command either when $\overline{\text{CS}}$ is taken high or after a

timeout period. The communications interface is reset after the timeout period.

The following commands have no meaning in non-daisy chain systems such as:

- Identify
- ACK
- NAK

The Sleep and Wakeup commands are sent as normal commands.

The device resets on receipt of the Reset command.

Alarm Signals

The $\overline{\text{FAULT}}$ logic output is asserted low in response to a fault condition. The output then remains low until the bits of the Fault Status register are reset. The host microcontroller writes 14'h0000 to this register to clear the bits. Bits in the fault data registers must first be cleared before the associated bits in the Fault Status register can be cleared. Additionally, the fault status of each part may be obtained at any time by reading the Fault Status register.

The $\overline{\text{FAULT}}$ logic output is asserted in **Sleep mode**, if a fault has been detected and has not been cleared.

Communication Faults

There is no specific response to a communications fault. A fault is indicated by an absence of normal communications function.

Non-daisy chain device responses are 2-byte sequences containing 14-bit data with leading zeros. Non-daisy chain responses are conducted without CRC (Cyclical Redundancy Check) error detection.

Fault Response in Sleep Mode

When a standalone device is in **Sleep mode**, the device may still detect faults if operating in the **Scan Continuous mode**. If an error occurs, the **FAULT** output pin is asserted low.

Example Communications

An example read response is shown in [Figure 35](#).

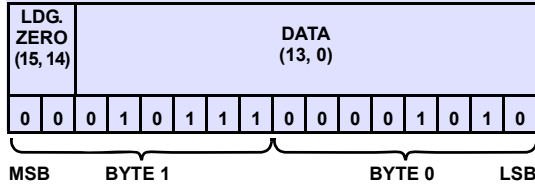

FIGURE 35. NON-DAISY CHAIN DEVICE RESPONSE EXAMPLE: CELL 7 VOLTAGE = 16'h170A (3.6V)

Examples of the various write command structures for non-daisy chain installations are shown in [Figures 36A](#) through [36F](#).

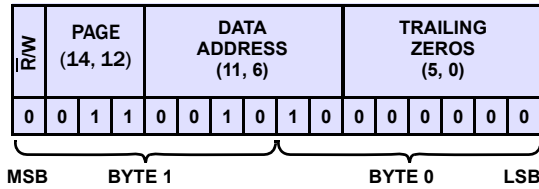

FIGURE 36A. DEVICE LEVEL COMMAND: SLEEP

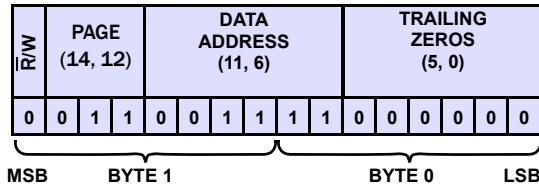

FIGURE 36B. DEVICE LEVEL COMMAND: WAKE UP

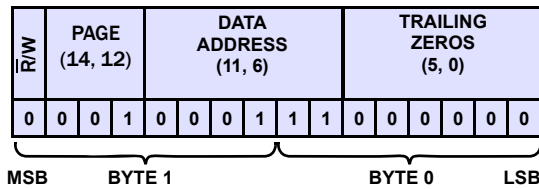

FIGURE 36C. DEVICE READ: GET CELL 7 DATA

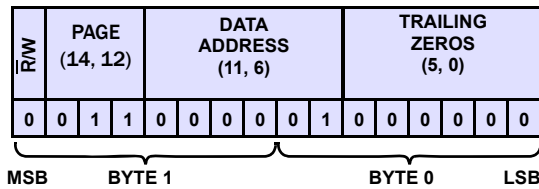

FIGURE 36D. DEVICE LEVEL COMMAND: SCAN VOLTAGES

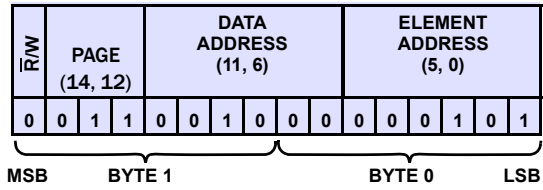

FIGURE 36E. DEVICE LEVEL COMMAND: MEASURE CELL 5 VOLTAGE

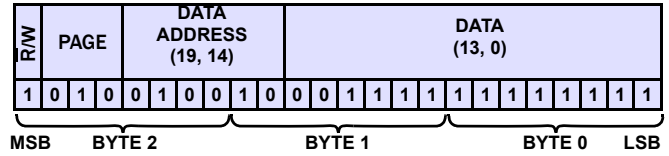

FIGURE 36F. DEVICE WRITE: WRITE EXTERNAL TEMPERATURE LIMIT = 14'h0FFF

FIGURE 36. NON-DAISY CHAIN DEVICE READ AND WRITE EXAMPLES

Daisy Chain Systems

The daisy chain communication is intended for use with large stacks of battery cells where a number of ISL94212 devices are used.

Daisy Chain Ports

A daisy chain consists of a bottom device, a top device and up to 12 middle devices. The ISL94212 device located at the bottom of the stack is called the Master and communicates to the host microcontroller using SPI communications and to other ISL94212 devices using the daisy chain port. Each middle device provides two daisy chain ports: one is connected to the ISL94212 above in the stack and the other to the ISL94212 below. Communications between the SPI and daisy chain interfaces are buffered by the master device to accommodate timing differences between the two systems.

The daisy chain ports are fully differential, DC balanced, bidirectional and AC-coupled to provide maximum immunity to EMI and other system transients while only requiring two wires for each port. Four operating data rates are available and are configurable by pin selection using the COMMS RATE 0 and COMMS RATE 1 pins (see [Table 17](#)).

TABLE 17. DAISY CHAIN COMMUNICATIONS DATA RATE SELECTION

COMMS RATE 0	COMMS RATE 1	DATA RATE (kHz)
0	0	62
0	1	125
1	0	250
1	1	500

Maximum operating data rates is 2Mbps for the SPI interface. When using the daisy chain communications system it is recommended that the synchronous communications data rate be at least twice that of the daisy chain system.

The communications pins are monitored when the device is in **Sleep mode**, allowing the part to wake up in response to communications.

Communications Protocol

All daisy chain communications are passed from device to device such that all devices in the stack receive the same information. Each device then decodes the message and responds as needed. The originating device (Master in the case of commands, addressed device or top stack device in the case of responses) generates the system clock and data stream. Each device delays the data stream by one clock cycle. Each device knows its stack location (see command [“Identify” on page 40](#)). Each device knows the total number of devices in the stack. Each originating device adds a number of clock pulses to the daisy chain data stream to allow transmission through the stack.

All communications from the host microcontroller are passed from device to device to the last device in the chain (top device). The top device responds to read and write messages with an “ACK” (or with the requested data if this is the addressed device and the message was a read command). The addressed device then waits to receive the “ACK” before responding. With data, in the case of a read, or with an “ACK” in the case of a write. Action commands such as the Scan commands do not require a response.

A read or write communications transmission is only considered to be complete following receipt of a response from the target device or the identification of a communications fault condition. The host microcontroller should not transmit further data until either a response has been received from the target stack device or a communications fault condition has been identified. A normal daisy chain communications sequence for a stack of 10 devices: read device 4, cell 7 data, is illustrated in [Figure 37 on page 35](#). The maximum response time: time from the rising edge of CS at the end of the first byte of a read/write command, sent by the host microcontroller, to the assertion of DATA READY by the master device, is given in [Table 18](#) for various daisy chain data rates.

TABLE 18. MAXIMUM RESPONSE TIMES FOR DAISY CHAIN READ AND WRITE COMMANDS. STACK OF 10 DEVICES

Daisy Chain Data Rate	MAXIMUM TIME TO ASSERTION OF DATA READY				UNIT
	500	250	125	62.5	
Daisy Chain Data Rate	500	250	125	62.5	kHz
Response Time	240	480	960	1920	µs

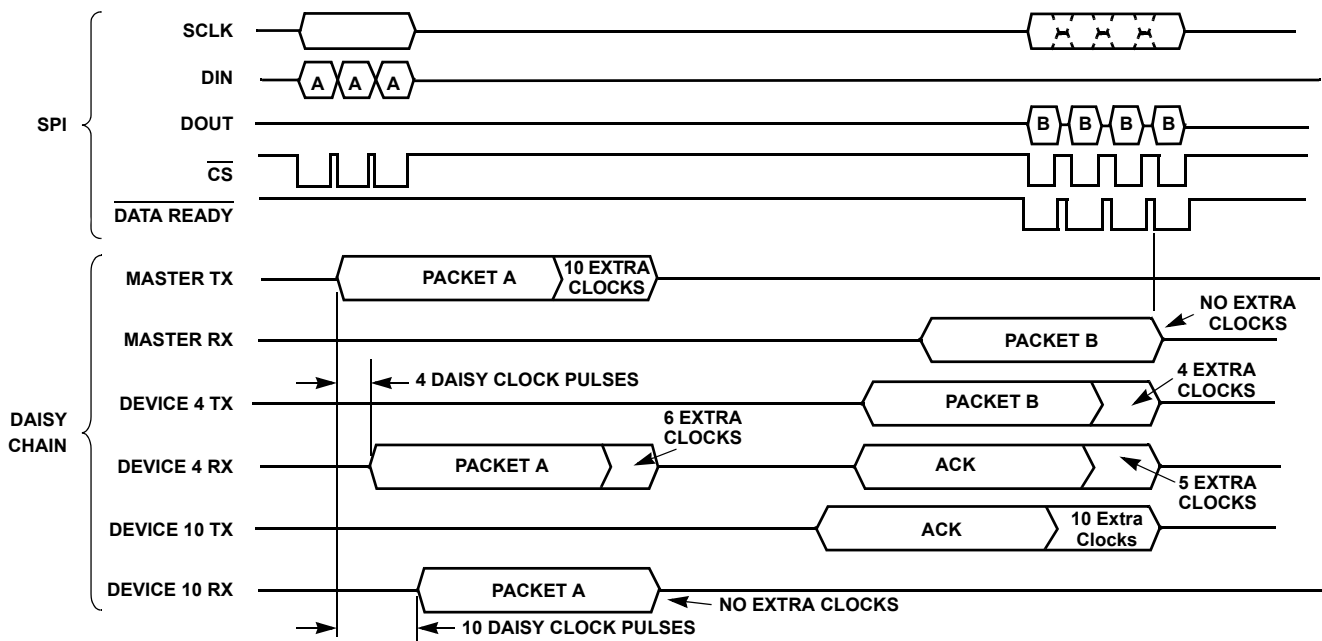

- Host microcontroller sends “Read device 4, cell 7” = Packet A
- Master begins relaying Packet A following receipt of the 1st byte of A. Master adds 10 extra clock cycles to allow all stack devices to relay the message.
- Device 4 receives and decodes “Read device 4, cell 7” and waits for a response from top stack device.
- Top stack device (device 10) receives and decodes Packet A.
- Device 10 responds “ACK”. Device 10 adds 10 clock cycles to allow all stack devices to relay the message.
- Device 4 receives and decodes ACK.
- Device 4 transmits the cell 7 data = Packet B. Device 4 subtracts one clock cycle to synchronize timing for lower stack devices to relay the message.
- Master asserts $\overline{\text{DATA READY}}$ after receiving the 1st byte of Packet B.
- Host responds by asserting $\overline{\text{CS}}$ and clocking out 8 bits of data from DOUT. $\overline{\text{CS}}$ is taken high following the 8th bit. The master responds by taking $\overline{\text{DATA READY}}$ high and tri-stating DOUT. Master asserts $\overline{\text{DATA READY}}$ after receiving the next byte and so on.

FIGURE 37. DAISY CHAIN READ EXAMPLE “READ DEVICE 4, CELL 7”, STACK OF 10 DEVICES

TABLE 19. ISL94212 DATA INTERPRETATION RULES FOR DAISY CHAIN INSTALLATIONS

FIRST 4 BITS IN SEQUENCE	5 TH BIT (R/W)	PAGE	DATA ADDRESS	INTERPRETATION
Stack address [3:0] (nonzero)	0	011	001000	Measure command. Data address is followed by 6-bit element address.
0000	0	011	001001	Identify command. Data address is followed by device count data.
Stack address [3:0] (nonzero)	0	Any	All other	Device Read command. Data address is followed by 6 zeros.
Stack address [3:0] (nonzero)	1	Any	Any	Device Write command.

Communication Sequences

All Daisy chain device responses are 4-byte sequences, except for the responses to the Read All command. All responses start with the device stack address. All responses use a 4-bit CRC. The response to the “Read All Commands” is to send a normal 4-byte data response for the first data segment and continue sending the remaining data segments in 3-byte sections composed of data address, data and CRC. This creates an anomaly with the normal CRC usage in that the first 4 bytes have a 4-bit CRC at the end (operating on 3.5 bytes of data) while the remaining bytes have a CRC which only operates on 2.5 bytes. The host microcontroller, having requested the data, must be prepared for this.

Daisy chain devices require device stack address information to be added to the basic command set. Daisy chain writes are 4-byte sequences. Daisy chain reads are 3 bytes. Action commands, such as scan and communications administration commands are treated as reads. Daisy chain communications employ a 4-bit CRC (Cyclic Redundancy Check) using a polynomial of the form $1 + x + x^4$. The first four bits of each Daisy chain transmission contain the stack address, which can be any number from 0001 to 1110. All devices respond to the Address All (1111) and Identify (0000) stack addresses. The fifth bit is set to ‘1’ for write and ‘0’ for read. The rules for daisy chain installations are shown in [Table 19](#).

CRC Calculation

Daisy chain communications employ a 4-bit CRC using a polynomial of the form $1 + x + x^4$. The polynomial is implemented as a 4 stage internal XOR standard linear feedback shift register as shown in [Figure 38](#). The CRC value is calculated using the base command data only. The CRC value is not included in the calculation.

The host microcontroller calculates the CRC when sending commands or writing data. The calculation is repeated in the ISL94212 and checked for compliance. The ISL94212 calculates the CRC when responding with data (device reads). The host microcontroller then repeats the calculation and checks for compliance.

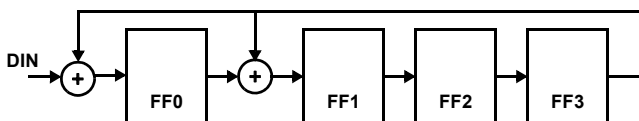

FIGURE 38. 4-BIT CRC CALCULATION

```

Attribute VB_Name = "isl94212evb_crc4_lib"
' File - isl94212evb_crc4_lib.bas
' Copyright (c) 2010 Intersil
'-----
Option Explicit
*****
' CRC4 Routines
*****
Public Function CheckCRC4(myArray() As Byte) As Boolean
' returns True if CRC4 checksum (low nibble of last byte in myarray)
' is good. Array can be any length

Dim crc4 As Byte
Dim lastnibble As Byte

lastnibble = myArray(UBound(myArray)) And &HF
crc4 = CalculateCRC4(myArray)

If lastnibble = crc4 Then
    CheckCRC4 = True
Else
    CheckCRC4 = False
End If

End Function

Public Sub AddCRC4(myArray() As Byte)
' adds CRC4 checksum (low nibble in last byte in array)
' array can be any length

Dim crc4 As Byte

crc4 = CalculateCRC4(myArray)
myArray(UBound(myArray)) = (myArray(UBound(myArray)) And
&HF0) Or crc4

End Sub

Public Function CalculateCRC4(ByRef myArray() As Byte) As Byte
' calculates/returns the CRC4 checksum of array contents excluding
' last low nibble. Array can be any length

Dim size As Integer
Dim i As Integer
Dim j As Integer
Dim k As Integer
Dim bit0 As Boolean, bit1 As Boolean, bit2 As Boolean, bit3 As
Boolean
Dim ff0 As Boolean, ff1 As Boolean, ff2 As Boolean, ff3 As Boolean
Dim carry As Boolean
Dim arraycopy() As Byte
Dim result As Byte

'copy data so we do not clobber source array
ReDim arraycopy(LBound(myArray) To UBound(myArray)) As Byte
For i = LBound(myArray) To UBound(myArray)
    arraycopy(i) = myArray(i)
Next

'initialize bits
bit0 = False
bit1 = False
bit2 = False
bit3 = False

'simple implementation of CRC4 (using polynomial 1 + X + X^4)
For i = LBound(arraycopy) To UBound(arraycopy)

'last nibble is ignored for CRC4 calculations
If i = UBound(arraycopy) Then
    k = 4
Else
    k = 8
End If

For j = 1 To k
' shift left one bit
carry = (arraycopy(i) And &H80) > 0
arraycopy(i) = (arraycopy(i) And &H7F) * 2

'see ISL94212 datasheet, Fig 11: 4-bit CRC calculation
ff0 = carry Xor bit3
ff1 = bit0 Xor bit3
ff2 = bit1
ff3 = bit2
bit0 = ff0
bit1 = ff1
bit2 = ff2
bit3 = ff3
Next j
Next i

'combine bits to obtain CRC4 result
result = 0
If bit0 Then
    result = result + 1
End If
If bit1 Then
    result = result + 2
End If
If bit2 Then
    result = result + 4
End If
If bit3 Then
    result = result + 8
End If

CalculateCRC4 = result

End Function

```

FIGURE 39. CRC CALCULATION ROUTINE (VISUAL BASIC) EXAMPLE

Daisy Chain Addressing

When used in a daisy chain system each individual device dynamically assigns itself a unique address (see “Identify” on page 40). In addition, all daisy chain devices respond to a common address allowing them to be controlled simultaneously (e.g., when using the balance enable and balance inhibit commands). See “Communication and Measurement Diagrams” on page 50 and “Communication and Measurement Timing Tables” on page 56.

The state of the COMMS SELECT 1, COMMS SELECT 2, COMMS RATE 0, and COMMS RATE 1 pins can be checked by reading the CSEL[2:1] and CRAT[1:0] bits in the Comms Setup register, (see Table 20). The SIZE[3:0] bits show the number of devices in the daisy chain and the ADDR[3:0] bits indicate the location of a device within the Daisy Chain.

TABLE 20. COMMS SETUP REGISTER (ADDRESS 6'h18)

7	6	5	4	3	2	1	0
		13	12	11	10	9	8
SIZE3	SIZE2	SIZE1	SIZE0	ADDR3	ADDR2	ADDR1	ADDR0
				CRAT1	CRAT0	CSEL2	CSEL1

Examples of the various read and write command structures for daisy chain installations are shown in Figures 40C through 40G. The MSB is transmitted first and the LSB is transmitted last.

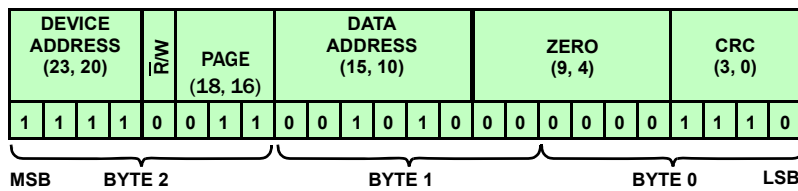

FIGURE 40A. DEVICE LEVEL COMMAND: SLEEP

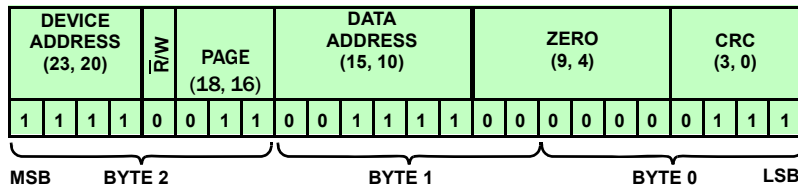

FIGURE 40B. DEVICE LEVEL COMMAND: WAKE UP

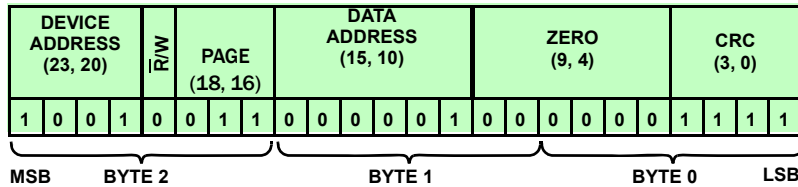

FIGURE 40C. DEVICE LEVEL COMMAND: DEVICE 9, SCAN VOLTAGES

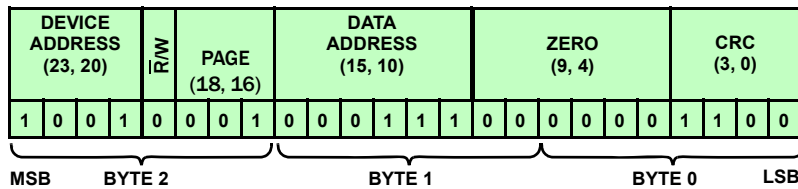

FIGURE 40D. DEVICE READ: DEVICE 9, GET CELL 7 DATA

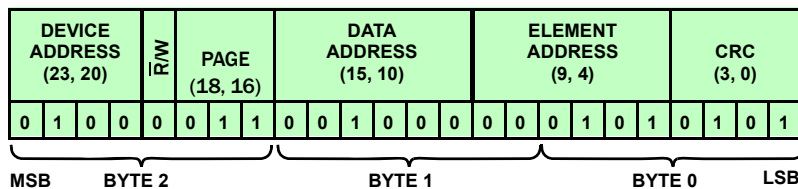

FIGURE 40E. ELEMENT LEVEL COMMAND: DEVICE 4, MEASURE CELL 5 VOLTAGE

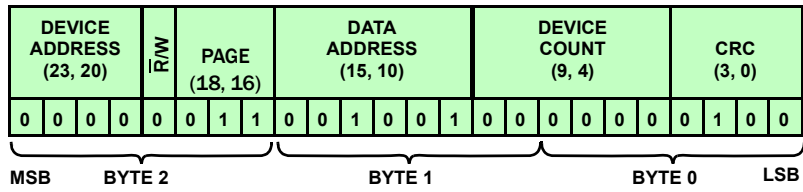

FIGURE 40F. IDENTIFY COMMAND

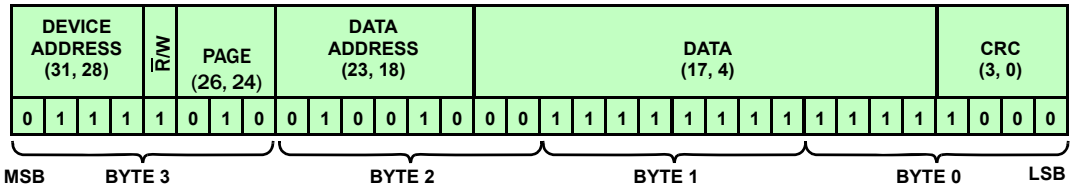

FIGURE 40G. DEVICE WRITE: DEVICE 7, WRITE EXTERNAL TEMPERATURE LIMIT = 14'h0FFF
 FIGURE 40. DAISY CHAIN DEVICE READ AND WRITE EXAMPLES

Response examples are shown in [Figures 41A](#) through [41D](#).

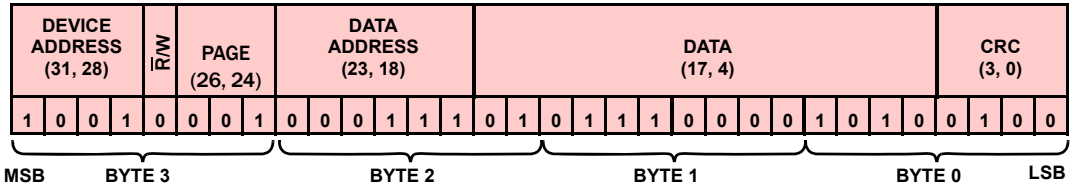

FIGURE 41A. DEVICE DATA RESPONSE: DEVICE 9, CELL 7 VOLTAGE = 14'h170A (3.6V)

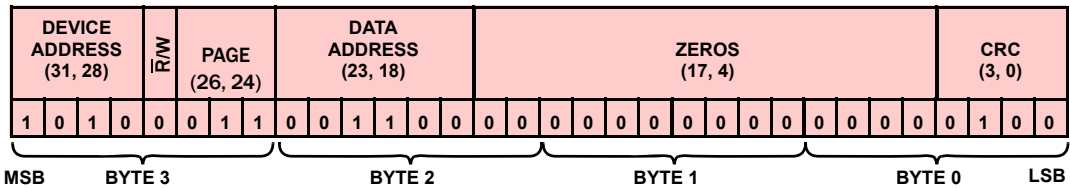

FIGURE 41B. DEVICE COMMUNICATIONS ADMINISTRATION RESPONSE: DEVICE 10, ACK

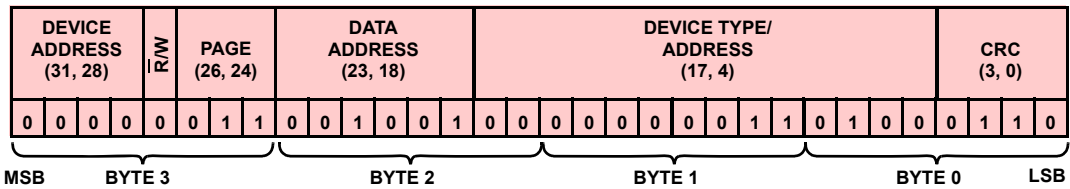

FIGURE 41C. DEVICE COMMUNICATIONS ADMINISTRATION RESPONSE: IDENTIFY, DEVICE 4, MID STACK DEVICE

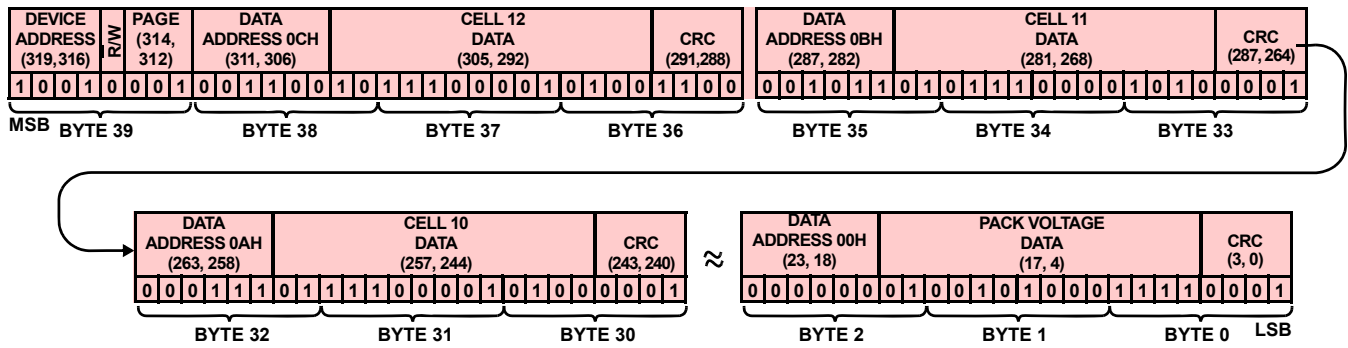

FIGURE 41D. DEVICE DATA RESPONSE: DEVICE 9, READ ALL CELL VOLTAGE DATA

FIGURE 41. DAISY CHAIN DEVICE RESPONSE EXAMPLES

Daisy Chain Commands

Normal communications include the normal usage of the read, write and system level commands. System level commands come in two types: action commands such as the scan and measure commands which require the devices to perform measurements and administration commands such as Reset. Daisy chain devices also use commands such as ACK to indicate communications status. All Daisy chain communications, except the scan, measure and reset commands, require a response from the addressed device.

Identify

Identify mode is a special case mode that must be executed before any other communications to Daisy chained devices, except for the Sleep and Wakeup commands. The Identify command initiates address assignments to the devices in the Daisy chain stack.

While in **Identify mode** devices determine their stack position. **Identify mode** is entered on receipt of the “base” Identify command (this is the Identify command with the device address set to 6’h00). The Top stack device responds ACK on receiving the base identify command and then enters the **Identify mode**. Other stack devices wait to allow the ACK response to be relayed to the host microcontroller then they enter **Identify mode**. Once in **Identify mode** all stack devices except the Master load address 4’h0 to their stack address register. The Master (identified by the state of the Comms Select pins = 2’b01) loads 4’h1 to its stack address.

On receiving the ACK response the host microcontroller then sends the Identify command with stack address 6’h2 (i.e., 24’h0000 0011 0010 0100 **0010 0110**). The stack address is bolded. The last four bits are the corresponding CRC value. The Master passes the command onto the stack. The device at stack position 2 responds by setting the stack address bits (ADDR[3:0]) and stack size bits (SIZE[3:0]) in the Comms Setup register to 4’h2 and returns the identify response with CRC and an address of 6’h32 (i.e., 32’b0000 0011 0010 **0111 0010** 0000 0000 1111). The address bits are bolded. The address bits contains the normal stack address (2’h0010) and the state of the Comms Select pins (2’b11). Note that the in an identify response the data LSBs are always zero.

The host microcontroller then sends the Identify command with stack address 6’h3. Device 3 responds by setting its stack address and stack size information to 4’h3 and returning the identify response with address 6’h33. Devices 1 and 2 set their stack size information to 4’h3.

The process continues with the host microcontroller incrementing the stack address until all devices in the stack have received their stack address. Identified devices update their stack size information with each new transmission. The stack Top device (identified by the state of the Comms Select pins = 10) loads the stack address and stack size information and returns the Identify response with address 6’h2x, where x corresponds to the stack position of the Top device. The host microcontroller recognizes the top stack response and loads the total number of stack devices to local memory. The host microcontroller then sends the Identify command with data set to 6’h3F. Devices exit **Identify mode** on receipt of this command. The stack Top device responds ACK. An example Identify transmit and receive sequence for a stack of 3 devices is shown in [Figure 42](#).

When in **Normal mode**, only the base Identify command is recognized by devices. Any other Identify command variant or an Identify command sent with a nonzero stack address causes a NAK response from the addressed device(s).

Send Identify Command	Tx			0000	0011	0010	0100	0000	0100	03 24 04
	Rx	0000	0011	0011	0000	0000	0000	0000	1100	03 30 00 0C
Send Identify Device 2	Tx			0000	0011	0010	0100	0010	0110	03 24 26
	Rx	0000	0011	0010	0111	0010	0000	0000	1111	03 27 20 0F
Send Identify Device 3	Tx			0000	0011	0010	0100	0011	0111	03 24 37
	Rx	0000	0011	0010	0110	0011	0000	0000	0101	03 26 30 05
Send Identify Complete	Tx			0000	0011	0010	0111	1111	1110	03 27 FE
	Rx	0011	0011	0011	0000	0000	0000	0000	0001	33 30 00 01

FIGURE 42. IDENTIFY EXAMPLE. STACK OF 3 DEVICES

TABLE 21. IDENTIFY TIMING WITH DAISY CHAIN OPERATING AT 500kHz

NUMBER OF DEVICES (2 MINIMUM)	SPI COMMAND SEND TIME (µs)	DAISY TRANSMIT TIME (µs)	RESPONSE DELAY (µs)	DAISY RECEIVE TIME (µs)	SPI COMMAND RECEIVE TIME (µs)	TIME FOR EACH DEVICE (µs)	IDENTIFY TOTAL TIME (µs)	IDENTIFY + IDENTIFY COMPLETE TIME (µs)
1 (Master)	24	0	0	0	32	56	56	56
2	8	50	18	66	8	150	206	356
3	8	52	18	68	8	154	360	514
4	8	54	18	70	8	158	518	676
5	8	56	18	72	8	162	680	842
6	8	58	18	74	8	166	846	1012
7	8	60	18	76	8	170	1016	1186
8	8	62	18	78	8	174	1190	1364
9	8	64	18	80	8	178	1368	1546
10	8	66	18	82	8	182	1550	1732
11	8	68	18	84	8	186	1736	1922
12	8	70	18	86	8	190	1926	2116
13	8	72	18	88	8	194	2120	2314
14	8	74	18	90	8	198	2318	2516

IDENTIFY TIMING

To determine the time required to complete an identify operation, refer to [Table 21](#). In the table are two SPI command columns showing the time required to send the Identify command and receive the response (with an SPI clock of 1MHz.) In the case of the Master, there are no daisy chain clocks, so all three bytes of the send and four bytes of the receive are accumulated. For the daisy chain devices, the daisy communication overlaps with two of the SPI send bytes and with three of the SPI receive bytes, so there is no extra time needed for these bits.

Once the device receives the Identify command, it adds a delay time before sending the response back to the master. Then, on

receiving the daisy response, the Master sends the response to the Host through the SPI port.

There is a column showing the time for each Identify command and, in the second column from the right, is a column showing the total accumulated time required to send all Identify commands for each of the cell configurations. The final column on the right adds the Identify complete timing to the total. The Identify complete command takes the same number of clock cycles as the last Identify command.

TABLE 22. IDENTIFY TIMING WITH DAISY CHAIN OPERATING AT 250kHz

NUMBER OF DEVICES (2 MINIMUM)	SPI COMMAND SEND TIME (µs)	DAISY TRANSMIT TIME (µs)	RESPONSE DELAY (µs)	DAISY RECEIVE TIME (µs)	SPI COMMAND RECEIVE TIME (µs)	TIME FOR EACH DEVICE (µs)	IDENTIFY TOTAL TIME (µs)	IDENTIFY + IDENTIFY COMPLETE TIME (µs)
1 (Master)	24	0	0	0	32	56	56	56
2	8	100	34	132	8	282	338	620
3	8	104	34	136	8	290	628	918
4	8	108	34	140	8	298	926	1224
5	8	112	34	144	8	306	1232	1538
6	8	116	34	148	8	314	1546	1860
7	8	120	34	152	8	322	1868	2190
8	8	124	34	156	8	330	2198	2528
9	8	128	34	160	8	338	2536	2874
10	8	132	34	164	8	346	2882	3228
11	8	136	34	168	8	354	3236	3590
12	8	140	34	172	8	362	3598	3960
13	8	144	34	176	8	370	3968	4338
14	8	148	34	180	8	378	4346	4724

ACK (Acknowledge)

ACK is used by daisy chain devices to acknowledge receipt of a valid command. ACK is also useful as a communications test command: the stack top device returns ACK in response to successful receipt of the ACK command. No other action is performed in response to an ACK.

NAK (Not Acknowledge)

Receipt of an unrecognized command by either the target device or the top stack device results in a NAK being returned by that device. If a command addressed to all devices using the Address All stack address 1111 or the Identify stack address 0000 is not recognized by any device, then all devices not recognizing the command respond NAK. In this case, the host microcontroller receives the NAK response from the lowest stack device that failed to recognize the command. An incomplete command (e.g., one that is less than the length required) also causes a NAK to be returned.

Reset

All digital registers can be reset to their power-up condition using the *Reset* Command.

Daisy chain devices must be reset in sequence from top stack device to stack bottom (Master) device. Sending the *Reset* command to all devices using the address all stack address has no effect. There is no response from the stack when sending a *Reset* command.

All stack address and stack size information is set to zero in response to a *Reset* command. Once all devices have been reset it is necessary to reprogram the stack address and stack size information using the *Identify* command.

Note: A Reset command should be issued following a “hard reset” in which the EN pin is toggled.

Address All

The “Address All” stack address 1111 is used with device commands to cause all stack devices to perform functions simultaneously.

TABLE 23. “ADDRESS ALL” COMPATIBILITY

FUNCTION	“ADDRESS ALL” COMPATIBLE
Scan Voltages	Yes
Scan Temperatures	Yes
Scan Mixed	Yes
Scan Wires	Yes
Scan All	Yes
Scan Continuous	No
Scan Inhibit	No
Measure	No
Identify (special command – only responds to 0000 stack address)	No
Sleep	Yes
NAK	No
ACK	No
Comms Failure	No
Wakeup	Yes
Balance Enable	Yes

TABLE 23. "ADDRESS ALL" COMPATIBILITY (Continued)

FUNCTION	"ADDRESS ALL" COMPATIBLE
Balance Inhibit	Yes
Reset	No
Calculate Register Checksum	No
Check Register Checksum	No

Alarm Signals

Bits are set in the following fault data registers:

- Overvoltage register (address 6'h00),
- Undervoltage register (address 6'h01),
- Open Wires register (address 6'h02),
- Over-temperature register (address 6'h06)

Bits are also set in the Fault Status register (address 6'h04) in response to a fault being detected. Additionally, the bits from each of the fault data registers are OR'd and reflected to bits in the Fault Status register (one bit per data register).

A fault is registered when any of the bits in the Fault Status register is asserted. Two fault response methods are provided to indicate the existence of a fault: a fault response is sent via the daisy chain communications interface and the FAULT logic output is asserted low immediately on detection of the fault. The FAULT output remains low until the bits of all fault data registers and the Fault Status register are reset (host microcontroller writes 14'h0000 to these registers to clear the bits).

The Daisy chain fault response is immediate, as long as there is no communication activity on the device ports and comprises the normal fault status register read response. The fault response is only sent for the first fault occurrence. Subsequent faults do not activate the fault response until after the fault status register has been cleared.

If a fault occurs while the device ports are active, then the device waits until communication activity ceases before sending the fault response. The host microcontroller has the option to wait for this response before sending the next message. Alternately, the host microcontroller may send the next message immediately (after allowing the daisy chain ports to clear – see ["Sequential Daisy Chain communications" on page 55](#)). Any conflicts resulting from additional transmissions from the stack are recognized by the lack of response from the stack.

[Table 24](#) provides the maximum time from $\overline{\text{DATA READY}}$ going low for the last byte of the normal response to $\overline{\text{DATA READY}}$ going low for the first byte of the fault response in the case where a fault response is held up by active communications.

TABLE 24. MAXIMUM TIME BETWEEN $\overline{\text{DATA READY}}$ SIGNALS – DELAYED FAULT RESPONSE

SIGNALS	MAXIMUM TIME BETWEEN $\overline{\text{DATA READY}}$ ASSERTIONS				UNIT
	500	250	125	62.5	
Daisy Chain Data Rate	500	250	125	62.5	kHz
Fault Response	68	136	272	544	μs

Further, read communications to the device, return the fault response followed by the requested data. Write communications return only the fault response. Action commands return nothing. The host microcontroller resets the register bits corresponding to the fault by writing 14'h0000 to the Fault Status register, having first cleared the bits in the fault data register(s) if these are set. The device then responds ACK as with a normal write response since the fault status bits are now cleared. This also prevents further fault responses unless the fault reappears, in which case the fault response is repeated.

Watchdog Function

TABLE 25. WATCHDOG/BALANCE TIME REGISTER (ADDRESS 6'h15)

7	6	5 13	4 12	3 11	2 10	1 9	0 8
BTM0	WDG6	WDG5	WDG4	WDG3	WDG2	WDG1	WDG0
		BTM6	BTM5	BTM4	BTM3	BTM2	BTM1

A watchdog function is provided as part of the daisy chain communications fault detection system. The watchdog has no effect in non-daisy chain systems. The watchdog timeout is settable in two ranges using the lower 7 bits of the Watchdog/Balance time register (see [Table 25](#)). The low range (7'b0000001 to 7'b0111111) provides timeout settings in 1s increments from 1s to 63s. The high range (7'b1000000 to 7'b1111111) provide timeout settings in 2 minute intervals from 2 minutes to 128 minutes (see [Table 26](#) for details).

TABLE 26. WATCHDOG TIMEOUT SETTINGS

WDG[6:0]	TIMEOUT
0000000	Disabled
0000001	1s
0000010	2s
-	-
0111110	62s
0111111	63s
1000000	2 min
1000001	4 min
-	-
1111110	126 min
1111111	128 min

A zero setting (7'b0000000) disables the watchdog function. A watchdog password function is provided to guard against accidental disabling of the watchdog function. The upper 6 bits of the Device Setup register must be set to 6'h3A (111010) to allow the watchdog to be set to zero. The watchdog is disabled by first writing the password to the Device Setup register (see [Table 13 on page 30](#)) and then writing zero to the lower bits of the Watchdog/Balance time register. The password function does not prevent changing the watchdog timeout setting to a different nonzero value.

Each device must receive a valid communications sequence before its watchdog timeout period is exceeded. Failure to receive valid communications within the required time causes the WDG \overline{F} bit to be set in the Fault Status register and the device to be placed in **Sleep mode**, with all measurement and balancing functions disabled. Daisy chain devices assert the \overline{FAULT} output in response to a watchdog fault and maintain this asserted state while in **Sleep mode**. Notice that no watchdog fault response is automatically sent on the daisy chain interface.

The watchdog continues to function when the ISL94212 is in **Sleep mode**. Parts in **Sleep mode** assert the \overline{FAULT} output when the watchdog timer expires.

A valid communications sequence is one that requires an action or response from the device. Address All commands, such as the Scan and Balance commands provide a simple way to reset the watchdog timers on all devices with a single communication. Single device communications (e.g., **ACK**) must be sent individually to each device to reset the watchdog timer in that device. A read of the Fault Status register of each device is also a good way to reset the watchdog timer on each device. This functionality guards against situations where a runaway host microcontroller might continually send data.

Communications Faults

Communication Failure

All commands except the Scan, Measure and Reset commands require a response from either the stack top device or the target device (see [Table 27](#)), each device in the stack waits for a response from the stack device above. Correct receipt of a command is indicated by the correct response. Failure to receive a response within a timeout period indicates a communications fault. The timeout value is stack position dependent. The device that detects the fault then transmits the Communications Failure response, which includes its stack address.

TABLE 27. SUMMARY OF NORMAL COMMUNICATIONS RESPONSES AND THE COMMUNICATIONS TIMEOUT FUNCTION

COMMAND	TOP STACK DEVICE RESPONSE	TARGET DEVICE RESPONSE	DEVICE WAITS FOR A RESPONSE FOR THIS COMMAND?
Read	ACK	Data	Yes
Write	ACK	ACK	Yes
Scan Voltages	-	-	No
Scan Temperatures	-	-	No
Scan Mixed	-	-	No
Scan Wires	-	-	No
Scan All	-	-	No
Scan Continuous	ACK	ACK	No
Scan Inhibit	ACK	ACK	No
Measure	-	-	No
Identify	ACK	NAK	No

TABLE 27. SUMMARY OF NORMAL COMMUNICATIONS RESPONSES AND THE COMMUNICATIONS TIMEOUT FUNCTION (Continued)

COMMAND	TOP STACK DEVICE RESPONSE	TARGET DEVICE RESPONSE	DEVICE WAITS FOR A RESPONSE FOR THIS COMMAND?
Sleep	ACK	NAK	No
NAK	ACK	ACK	Yes
ACK	ACK	ACK	Yes
Comms Failure (Note)	NAK	NAK	Yes
Wakeup	ACK	NAK	No
Balance Enable	ACK	ACK	Yes
Balance Inhibit	ACK	ACK	Yes
Reset	-	-	No
Calc Checksum	ACK	ACK	Yes
Check Checksum	ACK	ACK	Yes

NOTE: Comms Failure is a device response only and has no meaning as a command.

If the target device receives a communications failure response from the device above then the target device relays the communications failure followed by the requested data (in the case of a read) or simply relays the communications failure only (in the case of a Write, Balance command, etc). The maximum time required to return the Communications Failure response to the host microcontroller (the time from the falling edge of the 24th clock pulse of an SPI command to receiving a $\overline{DATA\ READY}$ low signal) is given for various data rates in [Table 28](#).

TABLE 28. MAXIMUM TIME TO COMMUNICATIONS FAILURE RESPONSE

	MAXIMUM TIME TO ASSERTION OF $\overline{DATA\ READY}$				UNIT
	500	250	125	62.5	
Daisy Chain Data Rate	500	250	125	62.5	kHz
Communications Failure Response	5.8	11.6	23.2	46.4	ms

A communications fault can be caused by one of three circumstances: the communications system has been compromised, the device causing the fault is in **Sleep mode** or that a daisy chain input port is in the wrong idle state. This latter condition is unlikely but could arise in response to external influence, such as a large transient event. The daisy chain ports are forced to the correct idle condition at the end of each communication. An external event would have the potential to “flip” the input such that the port settles in the inverse state.

A flipped input condition recovers during the normal course of communications. If a flipped input is suspected, having received notification of a communications fault condition for example, the user may send a sequence of all 1's (e.g., FF FF FF FF) to clear the fault. Wait for the resulting NAK response and then send an ACK to the device that reported the fault. The “all 1” sequence allows a device to correct a flipped condition via normal end of the

communication process. The command FB FF FF FF also works and contains the correct CRC value (should this be a consideration in the way the control software is set up).

If the process mentioned previously results in a Communications Failure response, the next step is for the host microcontroller to send a Sleep command, wait for all stack devices to go to sleep, then send a Wakeup command. If successful then the host microcontroller receives an ACK once all devices are awake. In the case where a single stack device was asleep, the devices above the sleeping device would not have received the Sleep command and would respond to the Wakeup sequence with a NAK due to incomplete communications. The host microcontroller would then send a command (e.g., ACK) to check that all devices are awake. This process can be repeated as often as needed to wakeup sleeping devices.

In the event that the Wakeup command does not generate a response, this is a likely indication that the communications have been compromised. The host microcontroller may send a Sleep command to all units. If the communications watchdog is enabled then all parts go automatically into **Sleep mode** when the watchdog period expires so long as there are no valid communications activity. [Table 27](#) provides a summary of the normal responses and an indication if the device waits for a response from the various communications commands.

Scan Counter

A scan counter is provided to allow confirmation of receipt of the Scan and Measure commands. This is a 4-bit counter located in the Scan Count register (page 1, address 6'h16). The counter increments each time a Scan or Measure command is received. This allows the host microcontroller to compare the counter value before and after the Scan or Measure command was sent to verify receipt. The counter wraps to zero when overflowed.

The scan counter increments whenever the ISL94212 receives a Scan or Measure command. The ISL94212 does not perform a requested scan or measure function if there is already a scan or measure function in progress, but it still increments the scan counter.

Daisy Chain Communications Conflicts

Conflicts in the daisy chain system can occur if both a stack device and the host microcontroller are transmitting at the same time, or if more than one stack device transmits at the same time. Conflicts caused by a stack device transmitting at the same time as the host microcontroller are recognized by the absence of the required response (e.g., an ACK response to a write command), or by the scan counter not being incremented in the case of Scan and Measure commands.

Conflicts which arise from more than one device transmitting simultaneously can occur if two devices detect faults at the same time. This can occur when the stack is operating normally (e.g., if two devices register an undervoltage fault in response to a scan voltages command sent to all devices). It is recommended that the host microcontroller checks the Fault Status register contents of all devices whenever a Fault response is received from one device.

Memory Checksum

There are two checksum operations, one for the EEPROM and one for the Page 2 registers.

Two registers are provided to verify the contents of EEPROM memory. One (Page 4, address 6'h3F) contains the correct checksum value, which is calculated during factory testing at Intersil. The other (Page 5, address 6'h00) contains the checksum value calculated each time the nonvolatile memory is loaded to shadow registers, either after a power cycle or after a device reset. An inequality between these two numbers indicates corruption of the shadow register contents (and possible corruption of EEPROM data). The external microcontroller needs to compare the two registers, since it is not automatic. Resetting the device (using the Reset command) reloads the shadow registers. A persistent difference between these two register values indicates EEPROM corruption.

All Page 2 registers (device configuration registers) are subject to a checksum calculation. A Calculate Register Checksum command calculates the Page 2 checksum and saves the value internally (it is not accessible). The Calculate Register Checksum command may be run any time, but should be sent whenever a Page 2 register is changed.

A Check Register Checksum command recalculates the Page 2 checksum and compares it to the internal value. The occurrence of a Page 2 checksum error sets the PAR bit in the Fault Status register and causes a Fault response accordingly. The normal response to a PAR error is for the host microcontroller to rewrite the Page 2 register contents. A PAR fault also causes the device to cease any scanning or cell balancing activity.

See items 42 through 49 in [Table 30 on page 47](#).

Settling Time Following Diagnostic Activity

The majority of diagnostic functions within the ISL94212 do not affect other system activity and there is no requirement to wait before conducting further measurements. The exceptions to this are the open wire test and cell balancing functions.

Open Wire Test

The open wire test loads each V_{CN} pin in turn with 150µA or 1mA current. This disturbs the cell voltage measurement while the test is being applied e.g., a 1mA test current applied with an input path resistance of 1kΩ reduces the pin voltage by 1V. The time required for the cell voltage to settle following the open wire test is dependent on the time constant of components used in the cell input circuit. The standard input circuit ([Figure 50 on page 73](#)) with the components given in [Table 48 on page 77](#) provide settling to within 0.1mV in approximately 2.8ms. This time should be added at the end of each open wire scan to allow the cell voltages to settle.

Cell Balancing

The standard applications circuit ([Figure 50 on page 73](#)) configures the balancing circuits so that the cell input measurement reads close to zero volts when balancing is activated. There are time constants associated with the turn-on

and turn-off characteristics of the cell balancing system that must be allowed for when conducting cell voltage measurements.

The turn-on time of the balancing circuit is primarily a function of the 25 μ A drive current of the cell balancing output and the gate charge characteristic of the MOSFET and needs to be determined for a particular setup. Turn-on settling times to within 2mV of final “on” value are typically less than 5ms.

The turn-off time is a function of the MOSFET gate charge and the VGS connected resistor and capacitor values (for example R₂₇ and C₂₇ in [Figure 50 on page 73](#)) and is generally longer than the turn-on time. As with the turn-on case, the turn-off time needs to be determined for the particular components used. Turn-off settling times in the range 10ms to 15ms are typical for settling to within 0.1mV of final value.

Fault Signal Filtering

Filtering is provided for the cell overvoltage, cell undervoltage, V_{BAT} open and VSS open tests. These fault signals use a totalizing method in which an unbroken sequence of positive results is required to validate a fault condition. The sequence

length (number of sequential positive samples) is set by the [TOT2:0] bits in the Fault Setup register. See [Table 29](#).

Separate filter functions are provided for each cell input and for the V_{BAT} and VSS open faults. The filter is reset whenever a test results in a negative result (no fault). All filters are reset when the Fault Status register [TOT2:0] bits are changed. When a fault is detected, the [TOT2:0] bits should be rewritten.

The cell overvoltage, cell undervoltage, V_{BAT} open and VSS open faults are sampled at the same time at the end of a Scan Voltages command. The cell undervoltage and cell overvoltage signals are also checked following a Measure cell voltage command.

Fault Diagnostics

The ISL94212 incorporates extensive fault diagnostics functions, which include cell overvoltage and undervoltage as well as open cell input detection. The current status of all faults is accessible using the ISL94212 registers. [Table 30](#) shows a summary of commands and responses for the various fault diagnostics functions.

TABLE 29. FAULT TOTALIZING TIME (ms) AS A FUNCTION OF SCAN INTERVAL AND NUMBER OF TOTALIZED SAMPLES

SCAN INTERVAL CODE	SCAN INTERVAL (ms)	TOTALIZE – FAULT SETUP REGISTER							
		1 000	2 001	4 010	8 011	16 100	32 101	64 110	128 111
0000	16	16	32	64	128	256	512	1024	2048
0001	32	32	64	128	256	512	1024	2048	4096
0010	64	64	128	256	512	1024	2048	4096	8192
0011	128	128	256	512	1024	2048	4096	8192	16384
0100	256	256	512	1024	2048	4096	8192	16384	32768
0101	512	512	1024	2048	4096	8192	16384	32768	65536
0110	1024	1024	2048	4096	8192	16384	32768	65536	131072
0111	2048	2048	4096	8192	16384	32768	65536	131072	262144
1000	4096	4096	8192	16384	32768	65536	131072	262144	524288
1001	8192	8192	16384	32768	65536	131072	262144	524288	1048576
1010	16384	16384	32768	65536	131072	262144	524288	1048576	2097152
1011	32768	32768	65536	131072	262144	524288	1048576	2097152	4194304
1100	65536	65536	131072	262144	524288	1048576	2097152	4194304	8388608

TABLE 30. SUMMARY OF FAULT DIAGNOSTICS COMMANDS AND RESPONSES

ITEM	DIAGNOSTIC FUNCTION	ACTION REQUIRED	REGISTER READ/WRITE	COMMENTS
1	Static fault detection functions.	Check Fault Status (or look for normal fault response)	Read Fault Status register	The main internal functions of the ISL94212 are monitored continuously. Bits are set in the Fault Status register in response to faults being detected in these functions.
2	Oscillator check function	Check for device in Sleep mode if stack returns a Communications Failure response.		Oscillator faults are detected as part of the Static Fault detection functions. The response to an oscillator fault detection is to set the OSC bit in the Fault Status register and then to enter Sleep mode . A sleeping device does not respond to normal communications, producing a communications failure notification from the next device down the stack. The normal recovery procedure is send repeated Sleep and Wakeup commands ensure all devices are awake.
3	Cell overvoltage	Set cell overvoltage limit	Write Overvoltage Limit register	Full scale value 14'h1FFF = 5V
4		Set fault filter sample value	Write TOT bits in Fault Setup register	Default is 3'b011 (8 samples) - (see "Fault Setup:" on page 64)
5		Identify which inputs have cells connected	Write Cell Setup register	A '0' bit value indicates cell is connected. A '1' bit value indicates no cell connected to this input. The overvoltage test is not applied to unconnected cells.
6		Scan cell voltages	Send Scan Voltages command	A cell overvoltage condition is flagged after a number of sequential overvoltage conditions are recorded for a single cell. The number is programmed above in item 4.
7		Check fault status	Read Fault Status register	The device sends the Fault Status register contents automatically if a fault is detected, if the register value is zero before the fault is detected.
8		Check overvoltage fault register	Read Overvoltage Fault register	Only required if the Fault Status register returns a fault condition.
9		Reset fault bits		Reset bits in Overvoltage Fault register followed and bits in Fault Status register.
10		Reset fault filter		Change the value of the [TOT2:0] bits in the Fault Setup register and then change back to the required value. This resets the filter. The filter is also reset if a false overvoltage test is encountered.
11	Cell Undervoltage	Set cell Undervoltage Limit	Write Undervoltage Limit register	Full scale value 14'h1FFF = 5V
12		Set fault filter sample value	Write TOT Bits in Fault Setup register	Default is 3'b011 (8 samples)
13		Identify which inputs have cells connected	Write Cell Setup register	A '0' bit value indicates cell is connected. A '1' bit value indicates no cell connected to this input. The undervoltage test is not applied to unconnected cells.
14		Scan cell voltages	Send Scan Voltages command	A cell undervoltage condition is flagged after a number of sequential undervoltage conditions are recorded for a single cell. The number is programmed above in item 12.
15		Check Fault Status	Read Fault Status register	The device sends the Fault Status register contents automatically if a fault is detected, if the register value is zero before the fault is detected.
16		Check undervoltage fault register	Read undervoltage Fault register	Only required if the Fault Status register returns a fault condition.
17		Reset fault bits		Reset bits in undervoltage fault register followed by bits in Fault Status register.
18		Reset fault filter		Change the value of the [TOT2:0] bits in the Fault Setup register and then change back to the required value. This resets the filter. The filter is also reset if a false undervoltage test is encountered.
19	V _{BAT} or VSS Connection Test	Set fault filter sample value	Write TOT bits in Fault Setup register	Default is 3'b011 (8 samples)

TABLE 30. SUMMARY OF FAULT DIAGNOSTICS COMMANDS AND RESPONSES (Continued)

ITEM	DIAGNOSTIC FUNCTION	ACTION REQUIRED	REGISTER READ/WRITE	COMMENTS
20		Scan cell voltages	Send Scan Voltages command	A open condition on V_{BAT} or VSS is flagged after a number of sequential open conditions are recorded for a single cell. The number is programmed in item 19.
21		Check Fault Status	Read Fault Status register	The device sends the Fault Status register contents automatically if a fault is detected, if the register value is zero before the fault is detected.
22		Reset fault bits		Reset bits in the Fault Status register.
23		Reset fault filter		Change the value of the [TOT2:0] bits in the Fault Setup register and then change back to the required value. This resets the filter. The filter is also reset if a false open test is encountered.
24	Open Wire Test	Set Scan current value	Write Device Setup register: ISCN = 1 or 0	Sets scan current to 1mA (recommended) by setting ISCN = 1. Or, set the scan current to 150 μ A by setting ISCN = 0.
25		Identify which inputs have cells connected	Write Cell Setup register	A '0' bit value indicates cell is connected. A '1' bit value indicates no cell connected to this input. Cell inputs VC2 to VC12: the open wire detection system is disabled for cell inputs with a '1' setting in the Cell Setup register. Cell inputs VC0 and VC1 are not affected by the Cell Setup register.
26		Activate Scan Wires function	Send Scan Wires command	Wait for Scan Wires to complete.
27		Check Fault Status	Read Fault Status register	The device sends the <i>Fault Status</i> register contents automatically if a fault is detected, if the register value is zero before the fault is detected.
28		Check Open Wire Fault register	Read Open Wire Fault register	Only required if the Fault Status register returns a fault condition.
29		Reset fault bits		Reset bits in Open Wire Fault register followed by bits in Fault Status register.
30	Over-temperature Indication	Set External Temperature limit	Write External Temp Limit register	Full scale value 14'h3FFF = 2.5V
31		Identify which inputs are required to be tested	Write Fault Setup register bits TST1 to TST4	A '1' bit value indicates input is tested. A '0' bit value indicates input is not tested.
32		Scan temperature inputs	Send Scan Temperatures command	An over-temperature condition is flagged immediately if the input voltage is below the limit value.
33		Check Fault Status	Read Fault Status register	The device sends the <i>Fault Status</i> register contents automatically if a fault is detected, if the register value is zero before the fault is detected.
34		Check Over-temperature fault register	Read Over-temperature Fault register	Only required if the Fault Status register returns a fault condition.
35		Reset fault bits		Reset bits in Over-temperature Fault register followed by bits in Fault Status register.
36	Reference Check Function	Read reference coefficient A	Read Reference Coefficient A register	
37		Read reference coefficient B	Read Reference Coefficient B register	
38		Read reference coefficient C	Read Reference Coefficient C register	
39		Scan temperature inputs	Send Scan Temperatures command	
40		Read reference voltage value	Read Reference Voltage register	
41		Calculate voltage reference value		See Voltage Reference Check Calculation in the "Worked Examples" on page 86 of this data sheet.

TABLE 30. SUMMARY OF FAULT DIAGNOSTICS COMMANDS AND RESPONSES (Continued)

ITEM	DIAGNOSTIC FUNCTION	ACTION REQUIRED	REGISTER READ/WRITE	COMMENTS
42	Register Checksum	Calculate register checksum value	Send Calc Register Checksum command	This causes the ISL94212 to calculate a checksum based on the current contents of the page 2 registers. This action must be performed each time a change is made to the register contents. The checksum value is stored for later comparison.
43		Check register checksum value	Send Check Register Checksum command	The checksum value is recalculated and compared to the value stored by the previous Calc Register Checksum command. The PAR bit in the Fault Status register is set if these two numbers are not the same.
44		Check Fault Status	Read Fault Status register	The device sends the Fault Status register contents automatically if a fault is detected, if the register value is zero before the fault is detected.
45		Re-write registers	Load all page 2 registers with their correct values.	This is only required if a PAR fault is registered. It is recommended that the host reads back the register contents to verify values prior to sending a Calc Register Checksum command.
46		Reset fault bits		Reset bits in the Fault Status register.
47	EEPROM MISR Checksum	Read checksum value stored in EEPROM	Read the EEPROM MISR Register	
48		Read checksum value calculated by ISL94212	Read the MISR Checksum register	The checksum value is calculated each time the EEPROM contents are loaded to registers, either following the application of power, cycling the EN pin followed by a host initiated <i>Reset</i> command, or simply the host issuing a <i>Reset</i> command.
49		Compare checksum values		Correct function is indicated by the two values being equal. Memory corruption is indicated by an unequal comparison. In this event the host should send a <i>Reset</i> command and repeat the check process.

Sleep Mode

Devices enter **Sleep mode** in response to a Sleep command, a watchdog time out or in response to an oscillator fault. Devices wakeup in response to a Wakeup command or to a Scan Continuous cycle if the device was set to **Sleep mode** with **Scan Continuous mode** active.

Using a Sleep command or Wakeup command does not require that the devices in a stack are identified first. They do not need to know their position in the stack.

In a daisy chain system, the Sleep command must be written using the Address All stack address: **1111**. The command is not recognized if sent with an individual device address and causes the addressed device to respond NAK. The top stack device responds ACK on receiving a valid Sleep command.

Having received a valid Sleep command, devices wait before entering the **Sleep mode**. This is to allow time for the top stack device to respond ACK, or for all devices that don't recognize the command to respond NAK, and for the host microcontroller to respond with another command. Receipt of any valid communications on port 1 of the ISL94212 before the wait period expires cancels the Sleep command. Receipt of another Sleep command restarts the wait timers. [Table 31](#) provides the maximum wait time for various daisy chain data rates. The communications fault checking timeout is not applied to the Sleep command. A problem with the communications is indicated by a lack of response to the host microcontroller. The host microcontroller may choose to do nothing if no response is received in which case devices that received the Sleep command go to sleep when the wait time expires. Devices that do not receive the message go to sleep when their watchdog timer expires (as long as this is enabled).

TABLE 31. MAXIMUM WAIT TIME FOR DEVICES ENTERING SLEEP MODE

	MAXIMUM WAIT TIME FROM TRANSMISSION OF SLEEP COMMAND				UNIT
	500	250	125	62.5	
Daisy Chain Data Rate	500	250	125	62.5	kHz
Time to Enter Sleep mode	500	1000	2000	4000	µs

NOTE: Devices exit **Sleep mode** on receipt of a valid Wakeup command.

Wakeup

The host microcontroller wakes up a stack of sleeping devices by sending the Wakeup command to the Master stack device. The Wakeup command must be written using the Address All stack address: **1111**. The command is not recognized if sent with an individual device address and causes the Master device to respond NAK.

The Master exits **Sleep mode** on receipt of a valid Wakeup command and proceeds to transmit the Wakeup signal to the next device in the stack. The Wakeup signal is a few cycles of a 4kHz clock. Each device in the chain wakes up on receipt of the Wakeup signal and proceeds to send the signal onto the next device. Any communications received on port 1 by a device which is transmitting the Wakeup signal on port 2 are ignored. The Top stack device, after waking up, waits for some time before

sending an ACK response to the Master. This wait time is necessary to allow for the Wakeup signal being originated by a stack device other than the Master. See "Fault Response in Sleep Mode" in the following section for more information. The Master device passes the ACK on to the host microcontroller to complete the Wakeup sequence. The total time required to wakeup a complete stack of devices is dependent on the number of devices in the stack. [Table 32](#) gives the maximum time from Wakeup command transmission to receipt of ACK response (**DATA READY** asserted low) for stacks of 8 devices and 14 devices at various daisy chain data rates (interpolate linearly for different number of devices).

TABLE 32. MAXIMUM WAKEUP TIMES FOR STACKS OF 8 DEVICES AND 14 DEVICES (WAKEUP COMMAND TO ACK RESPONSE)

	MAXIMUM WAKEUP TIMES				UNIT
	500	250	125	62.5	
Daisy Chain Data Rate	500	250	125	62.5	kHz
Stack of 8 Devices	63	63	63	63	ms
Stack of 14 Devices	100	100	100	100	ms

There is no additional checking for communications faults while devices are waking up. A communications fault is indicated by the host microcontroller not receiving an ACK response within the expected time.

Fault Response in Sleep Mode

Devices may detect faults if operating in **Scan Continuous mode** while also in **Sleep mode**.

Daisy chain devices registering a fault in **Sleep mode** proceed to wakeup the other devices in the stack (e.g., Middle devices send the Wakeup signal on both ports). Any communications received by a device on one port while it is transmitting the Wakeup signal on its other port are ignored. After receiving the Wakeup signal, the top stack device waits before sending an ACK response on port 1. This is to allow other stack devices to wakeup. The total wait time is dependent on the number of devices in the stack. The time from a device detecting a fault to receipt of the ACK response is also dependent on the stack position of the device. See [Table 32](#) for maximum response times for stacks of 8 and 14 devices.

The normal host microcontroller response to receiving an ACK while the stack is in **Sleep mode** is to read the Fault Status register contents of each device in the stack to determine which device (or devices) has a fault.

Communication and Measurement Diagrams

Collecting voltage and temperature data from daisy chained ISL94212 devices consists of three separate types of operations: A Command to initiate measurement, the Measurement itself, and a Command and Response to retrieve data.

Commands are the same for all types of operations, but the timing is dependent on the number of devices in the stack, the daisy chain clock rate, and the SPI clock rate.

Actual measurement operations occur within the device and start with the last bit of the command byte and end with data being placed in a register. Measurement times are dependent on the ISL94212 internal clock. This clock has the same variations (and is related to) the daisy chain clock.

Responses have different timing calculations, based on the position of the addressed device in the daisy chain stack and the daisy chain and SPI clock rates.

Measurement Timing Diagrams

All measurement timing is derived from the ISL94212's internal oscillators. Figures given as typical are those obtained with the oscillators operating at their nominal frequencies and with any synchronization timing also at nominal value. Maximum figures are those obtained with the oscillators operating at their minimum frequencies and with the maximum time for any synchronization timing.

Measurement timing begins with a Start Scan signal. This signal is generated internally by the ISL94212 at the last clock falling edge of the Scan or Measure command. (This is the last falling edge of the SPI clock in the case of a standalone or Master device, or the last falling edge of the daisy chain clock, in the case of a daisy chain device). Daisy chain middle or top devices impose an additional synchronization delays. Communications sent on the SPI port are passed on to the Master device's daisy chain port at the end of the first byte of data. Then, for each device, there is an additional delay of one daisy chain clock cycle.

On receiving the Start Scan signal, the device initializes measurement circuits and proceeds to perform the requested measurement(s). Once the measurements are made, some

devices perform additional operations, such as checking for overvoltage conditions. The measurement command ends when registers are updated. At this time the registers may be read using a separate command. Refer to the ["SPI INTERFACE TIMING \(See Figures 2 and 3\)" on page 13](#) of the Electrical Specifications table for the time required to complete each measurement type. A more detailed timing breakdown is provided for each measurement type shown in the following.

See [Figure 43](#) for the measurement timing for a standalone device. See [Figure 44](#) for the measurement timing for daisy chain devices.

[Tables 34](#) through [39](#) give the typical and maximum timing for the critical elements of measurement process. Each table shows the timing from the last edge of the Scan command clock.

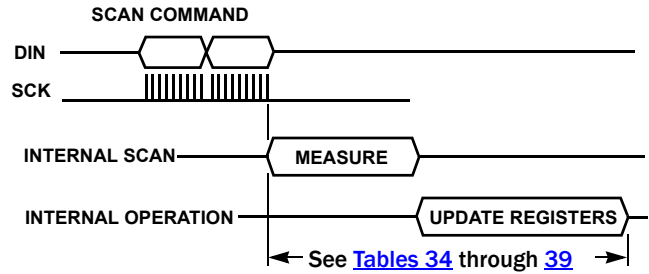

FIGURE 43. MEASUREMENT TIMING (STANDALONE)

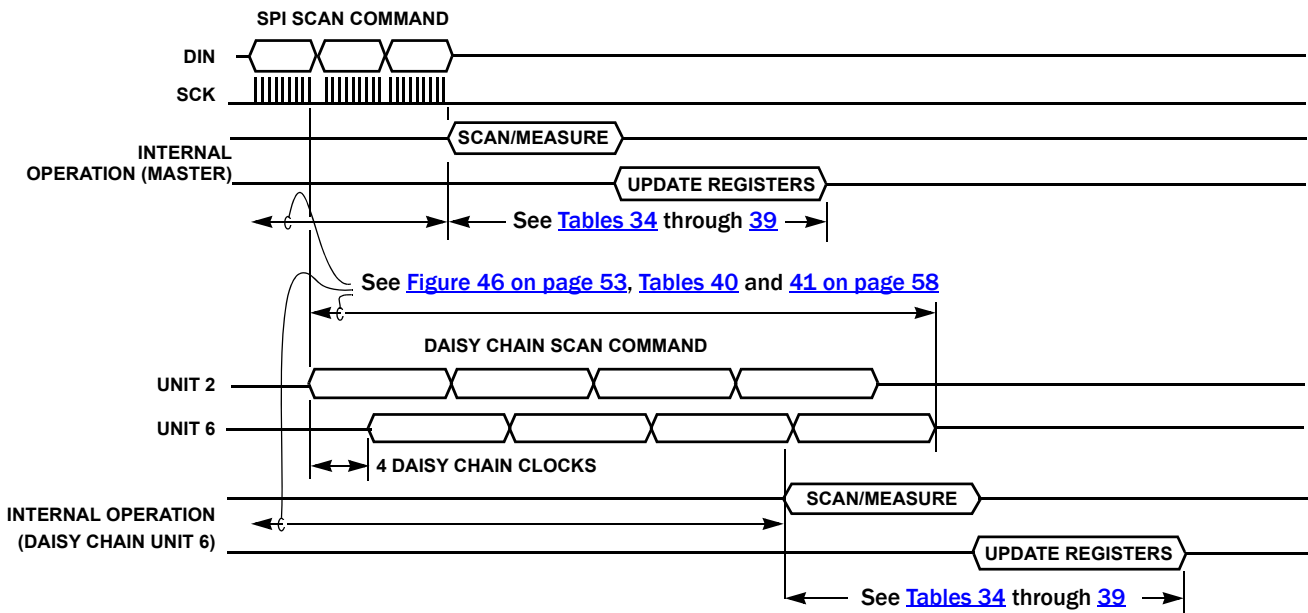
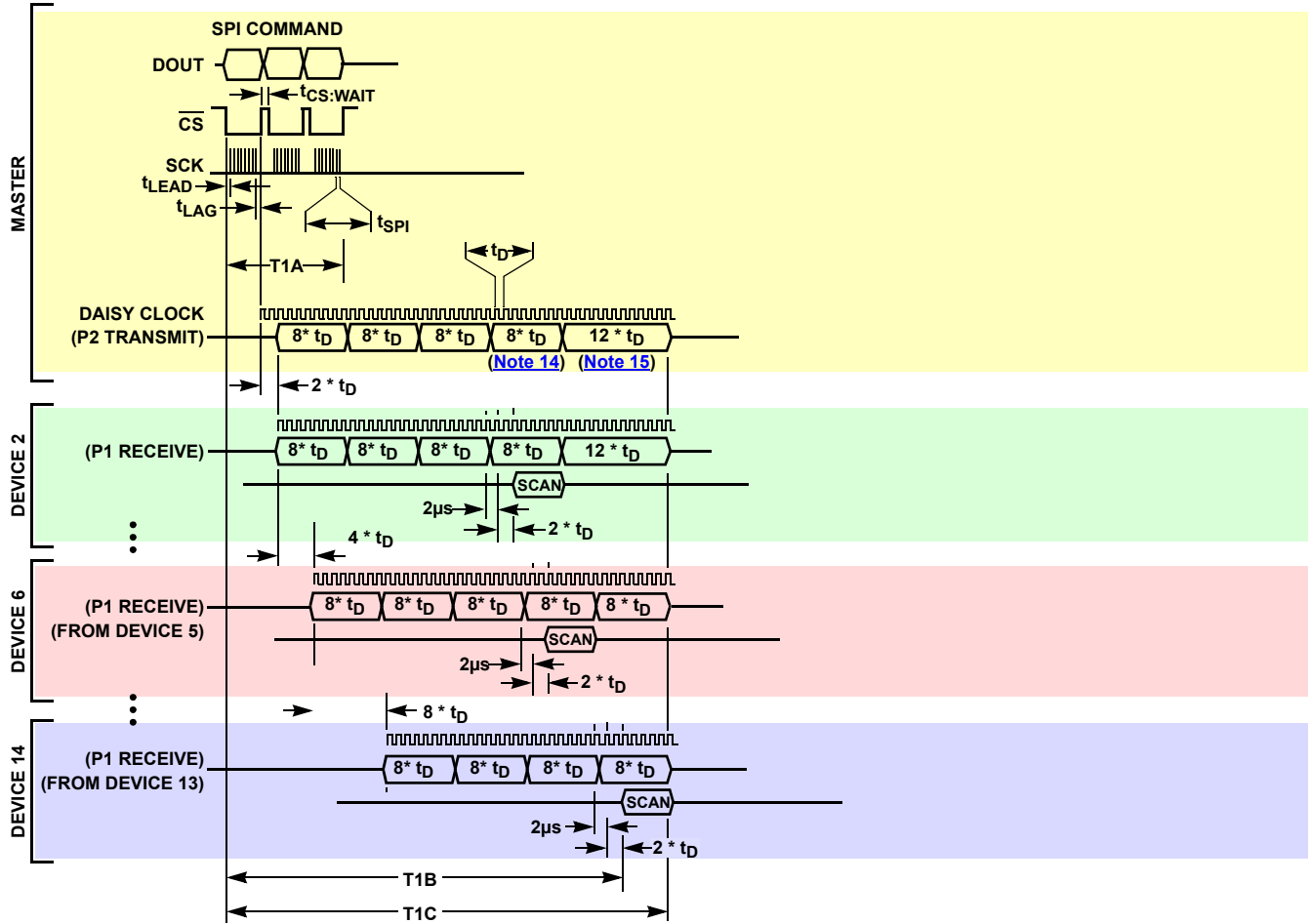

FIGURE 44. MEASUREMENT TIMING (6 DEVICE DAISY CHAIN).

Command Timing Diagram



To Start of Scan (Master)

$$T_{1A} = T_{SPI} \times 8 + T_{LEAD} + T_{LAG} \times 3 + 2 \times T_{CSWAIT}$$

To Start of Scan (Top/Middle)

$$T_{1B} = T_{SPI} \times 8 + T_{LEAD} + T_{LAG} + T_D \times (28 + n - 2) + 2\mu s$$

To End of Command

$$T_{1C} = T_{SPI} \times 8 + T_{LEAD} + T_{LAG} + T_D \times (34 + N - 2)$$

Where:

- T_{SPI} = SPI clock period
- T_D = Daisy chain clock period
- $T_{CS:WAIT}$ = \overline{CS} High time
- T_{LEAD} = \overline{CS} Low to first SPI Clock
- T_{LAG} = Last SPI Clock \overline{CS} High
- n = stack position of target device
- N = stack position of TOP device

COMMANDS:

- Scan Voltages
- Scan Temperatures
- Scan Mixed
- Scan Wires
- Scan All
- Measure
- Read
- Write
- Scan Continuous
- Scan Inhibit
- Sleep
- NAK

NOTES:

14. Master adds extra byte of zeros as part of Daisy protocol
15. Master adds N-2 clocks to allow communication to the end of the chain.

FIGURE 45. COMMAND TIMING

Response Timing Diagrams

Responses are different for Master, Middle, and Top devices. The response timings are shown in Figures 46, 47, and 48.

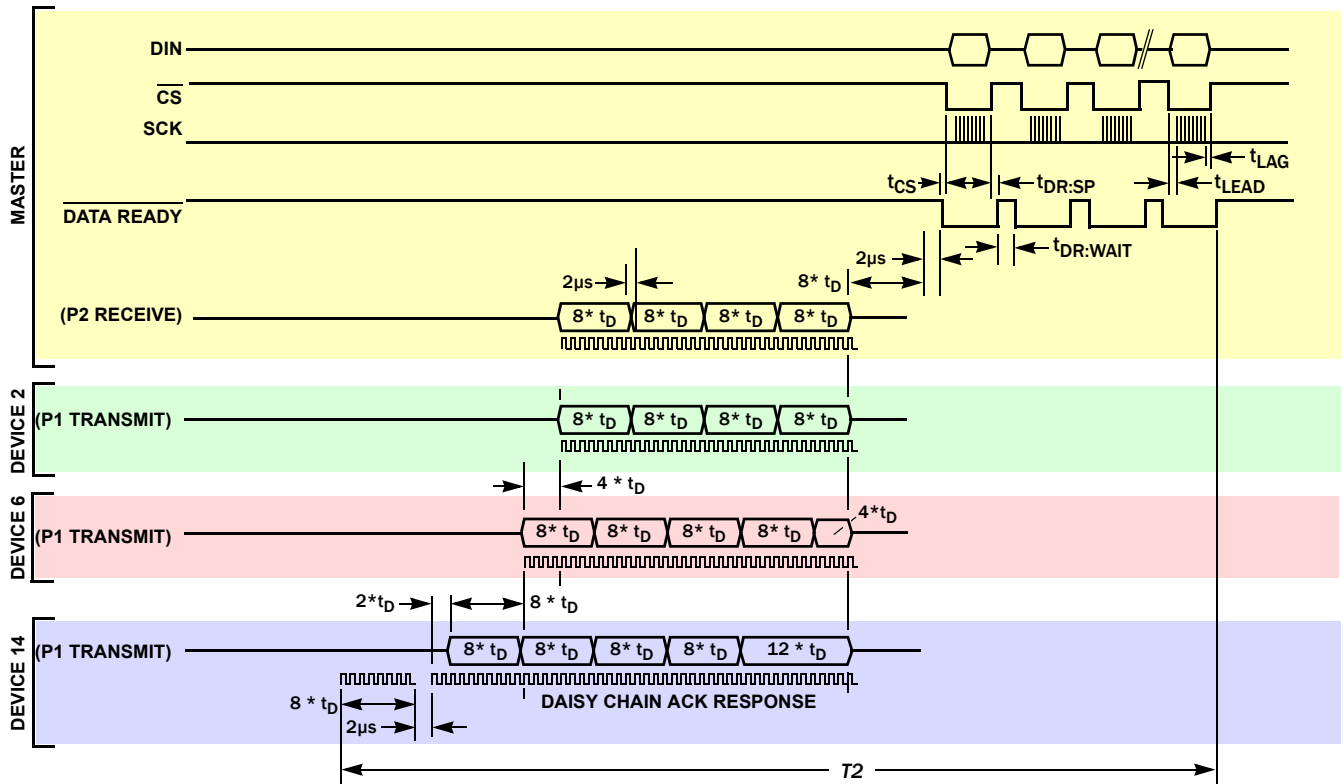

$$T2 = (8 \times T_{SPI} + T_{DRSP} + T_{DRWAIT} + T_{CS} + T_{LEAD} + T_{LAG}) \times D - T_{DRSP} + T_D \times (42 + N - 2 + 8) + 4\mu s$$

Where:

- T_{SPI} = SPI clock period
- T_D = Daisy Chain clock period
- T_{CS} = Host delay from DATA READY Low to the CS Low
- T_{DRSP} = CS High to DATA READY High
- T_{DRWAIT} = DATA READY High time
- T_{LEAD} = CS Low to first SPI Clock
- T_{LAG} = Last SPI Clock CS High
- N = Stack position of TOP device
- D = Number of data bytes
 - D = 4 for one register read (or ACK/NAK response)
 - D = 40 for read all voltages
 - D = 22 for read all temperatures
 - D = 22 for read all faults
 - D = 43 for read all setup

FIGURE 46. RESPONSE TIMING (MASTER DEVICE)

Response Timing Diagrams

Responses are different for Master, Middle, and Top devices. The response timings are shown in Figures 46, 47, and 48. (Continued)

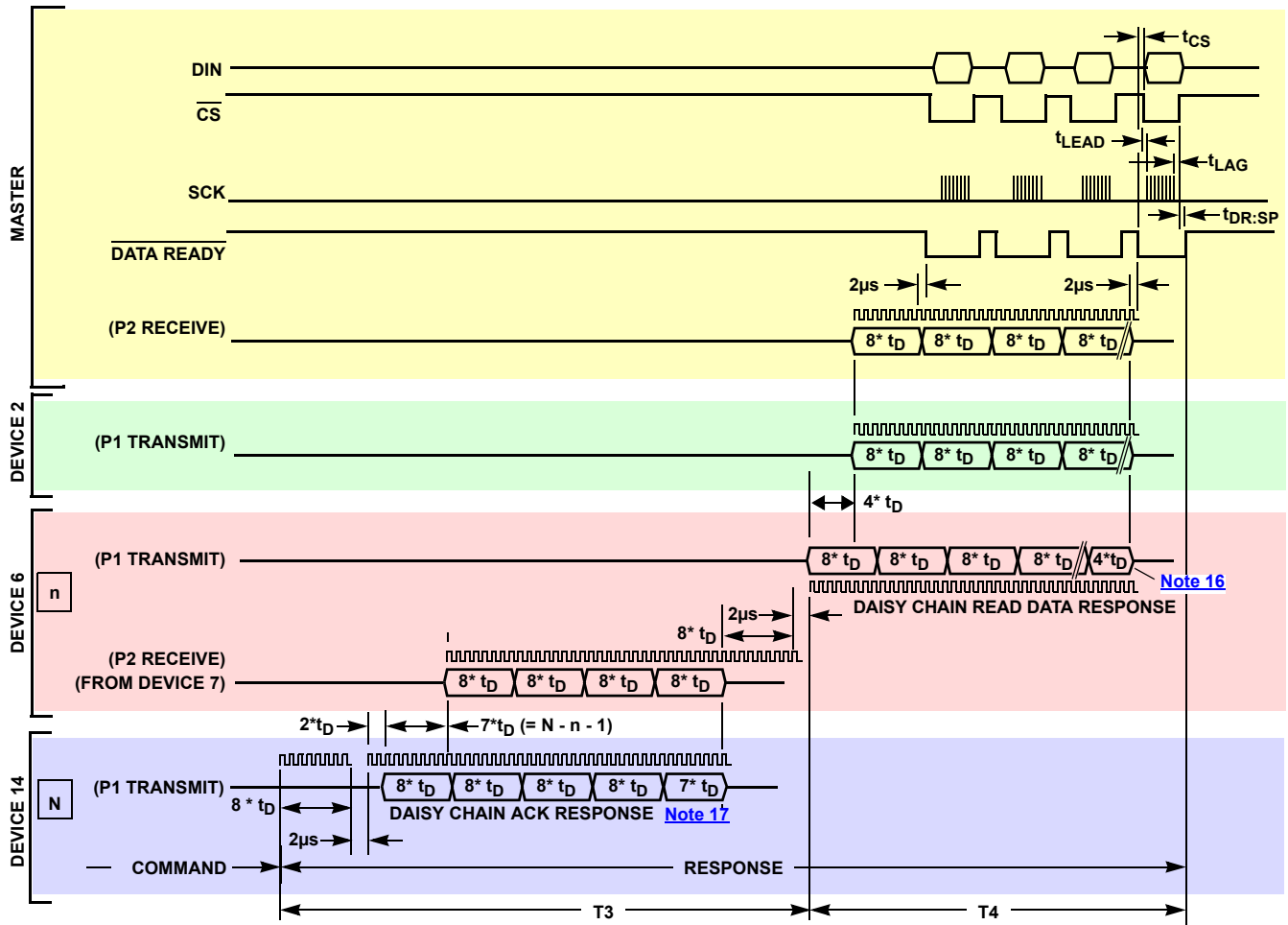

$$T_3 = T_D \times (50 + N - n - 1) + 4\mu s$$

$$T_4 = T_{SPI} \times 8 + T_{CS} + T_{LEAD} + T_{LAG} + T_{DRSP} + T_D \times (D \times 8 + n - 2) + 2\mu s$$

Where:

- T_D = Daisy Chain clock period
- T_{SPI} = SPI Clock Period
- N = Stack position of TOP device
- n = Stack position of MIDDLE stack device
- T_{CS} = Delay imposed by host from DATA READY to the first SPI clock cycle
- D = Number of bytes in the Middle stack device response e.g. read all cell data = 40 bytes, Register or ACK response = 4 bytes.

NOTES:

16. Top Device adds $(N - n - 1)$ Daisy clocks to allow communications to the targeted Middle Stack device.
17. Middle Stack Device adds $(n - 2)$ Daisy clocks to allow communications to the Master device.

FIGURE 47. RESPONSE TIMING (MIDDLE STACK DEVICE)

Response Timing Diagrams

Responses are different for Master, Middle, and Top devices. The response timings are shown in Figures 46, 47, and 48. (Continued)

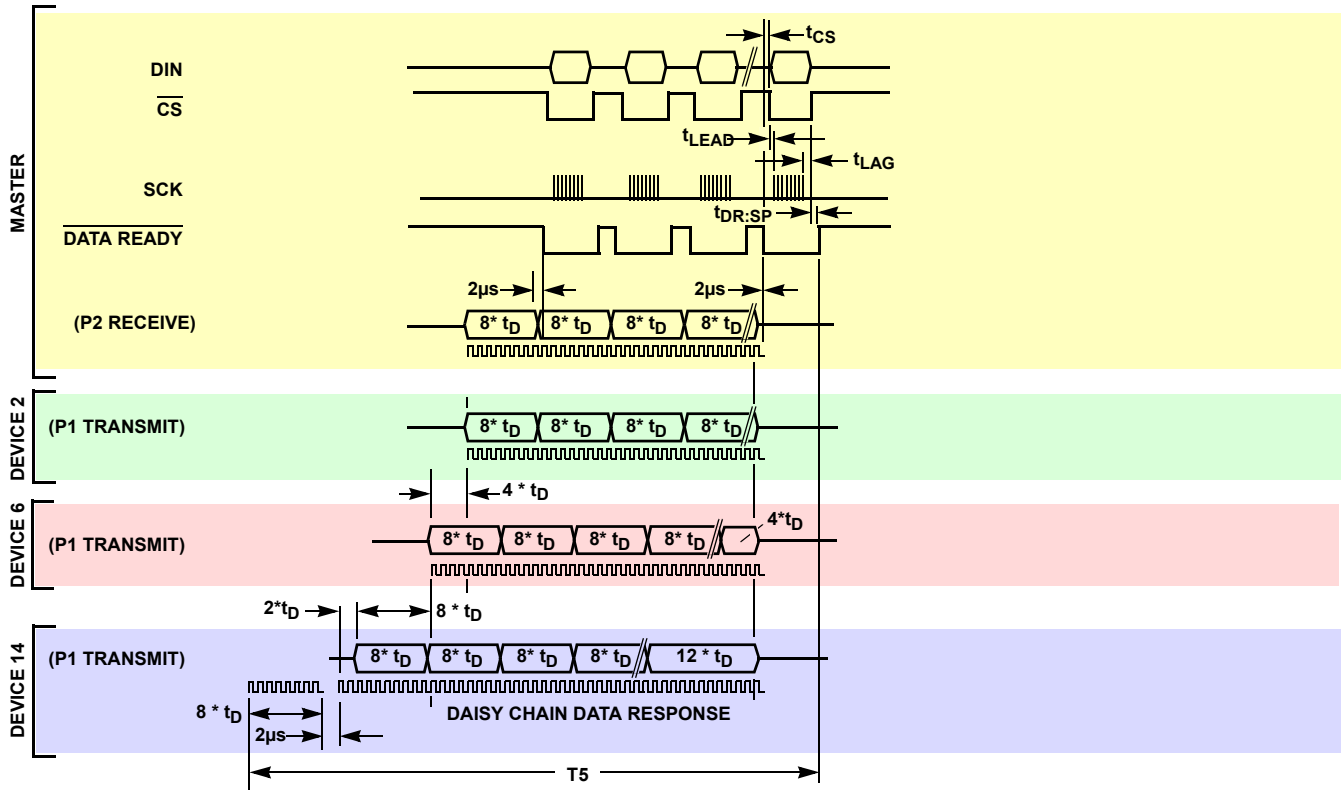

$$T_5 = T_{SPI} \times 8 + T_{LEAD} + T_{LAG} + T_{DRSP} + T_{CS} + T_D \times (D \times 8 + 10 + N - 2) + 4 \mu s$$

Where:

- T_{SPI} = SPI clock period
- T_D = Daisy Chain clock period
- T_{CS} = Host delay from DATA READY to the first SPI clock
- T_{DRSP} = CS High to DATA READY High
- T_{LEAD} = CS Low to first SPI Clock
- T_{LAG} = Last SPI Clock CS High
- N = stack position of TOP device
- D = Number of bytes in response

FIGURE 48. RESPONSE TIMING (TOP DEVICE)

SEQUENTIAL DAISY CHAIN COMMUNICATIONS

When sending a sequence of commands to the Master device, the host must allow time, after each response and before sending the next command, for the daisy chain ports of all stack devices (other than the Master) to switch to receive mode. This wait time is equal to 8 daisy chain clock cycles and is imposed from the time of the last edge on the Master's input daisy chain port to the last edge of the first byte of the subsequent command on the SPI, (see Figure 33). The minimum recommended wait time, between the host receiving the last edge of a response and sending the first edge of the next command, is given for the various daisy chain data rates in Table 33.

TABLE 33. MINIMUM RECOMMENDED COMMUNICATIONS WAIT TIME

	MAXIMUM TIME FOR DAISY CHAIN PORTS TO CLEAR				UNIT
	500	250	125	62.5	
Daisy Chain Data Rate					kHz
Communications Wait Time	18	36	72	144	µs

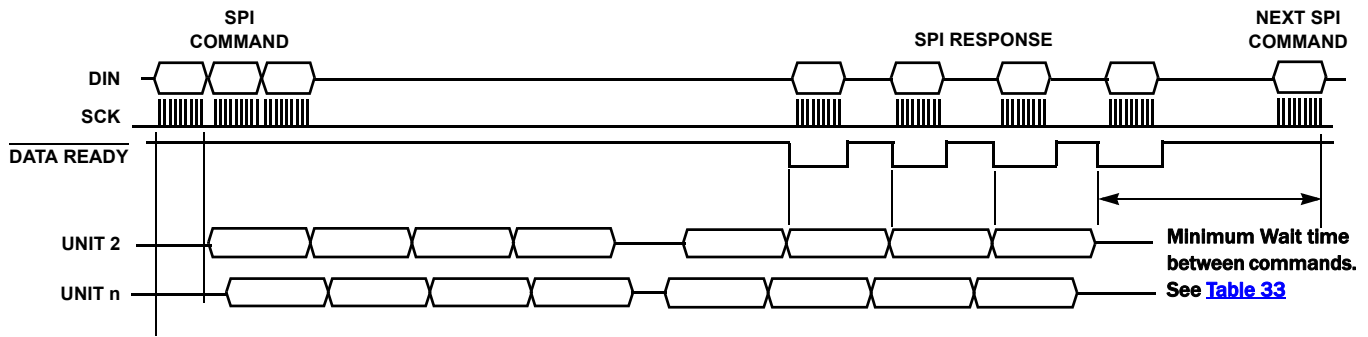

FIGURE 49. MINIMUM WAIT BETWEEN COMMANDS (DAISY CHAIN RESPONSE - TOP DEVICE)

Communication and Measurement Timing Tables

Measurement Timing Tables

SCAN VOLTAGES

The Scan Voltages command initiates a sequence of measurements starting with a scan of each cell input from cell 12 to cell 1, followed by a measurement of pack voltage. Additional measurements are then performed for the internal temperature and to check the connection integrity test of the VSS and V_{BAT} inputs. The process completes with the application of calibration parameters and the loading of registers. [Table 34](#) shows the times after the start of scan that the cell voltage inputs are sampled. The voltages are held until the ADC completes its conversion.

TABLE 34. SCAN VOLTAGES FUNCTION TIMING - DAISY CHAIN MASTER OR STANDALONE DEVICE

EVENT	TYP (μs)	MAX (μs)
Sample cell 12	17	19
Sample cell 11	38	42
Sample cell 10	59	65
Sample cell 9	81	89
Sample cell 8	102	112
Sample cell 7	123	135
Sample cell 6	144	159
Sample cell 5	166	182
Sample cell 4	187	206
Sample cell 3	208	229
Sample cell 2	229	252
Sample cell 1	251	276
Complete cell voltage capture (ADC complete). Sample VBAT	304	334
Complete VBAT voltage capture	318	349
Measure internal temperature	423	465
Complete VSS test	550	605
Complete VBAT test	726	799
Load registers	766	842

SCAN TEMPERATURES

The Scan Temperatures command turns on the TEMPREG output and, after a 2.5ms settling interval, samples the ExT1 to ExT4 inputs. TEMPREG turns off on completion of the ExT4 measurement. The Reference Voltage, IC Temperature and Multiplexer loopback function are also measured. The sequence is completed with respective registers being loaded.

TABLE 35. SCAN TEMPERATURES FUNCTION TIMING- DAISY CHAIN MASTER OR STANDALONE DEVICE

EVENT	ELAPSED TIME (μs)	
	TYP	MAX
Turn on TEMPREG	2	2
Sample ExT1	2518	2770
~		
Sample ExT4	2564	2820
Sample Reference	2584	2842
Measure Internal Temperature	2689	2958
Load registers	2689	2958

SCAN MIXED

The Scan Mixed command performs all the functions of the Scan Voltages command but interposes a measurement of the ExT1 input between the cell 7 and cell 6 measurements.

TABLE 36. SCAN MIXED FUNCTION TIMING – DAISY CHAIN MASTER OR STANDALONE DEVICE

EVENT	ELAPSED TIME (μs)	
	TYP	MAX
Sample cell 12	17	19
Sample cell 11	38	42
Sample cell 10	59	65
Sample cell 9	80	88
Sample cell 8	101	111
Sample cell 7	122	134
Complete cell voltage capture 12-7 Sample Ext1	176	194
Complete Ext1 capture	192	211
Sample cell 6	207	228
Sample cell 5	228	251
Sample cell 4	249	274
Sample cell 3	270	297
Sample cell 2	291	321
Sample cell 1	312	344
Complete cell voltage capture 6-1 Sample VBAT	367	404
Complete VBAT voltage capture	381	419
Load registers	829	911

SCAN WIRES

The Scan Wires command initiates a sequence in which each input is loaded in turn with a test current for a duration of 4.5ms (default). At the end of this time the input voltage is checked and the test current is turned off. The result of each test is recorded and the Open Wire Fault and Fault Status registers are updated (data latched) at the conclusion of the tests.

TABLE 37. SCAN WIRES FUNCTION TIMING – DAISY CHAIN MASTER OR STANDALONE DEVICE

EVENT	ELAPSED TIME (ms)	
	TYP	MAX
Turn on VC0 current	0.03	0.05
Test VC0	4.5	5.0
Turn on VC1 current	4.6	5.1
Test VC1	9.1	10.0
~		
Turn on VC12 current	54.9	60.3
Test VC12	59.4	65.3
Load registers	59.4	65.3

SCAN ALL

The Scan All command combines the Scan Voltages, Scan Wires and Scan Temperatures commands into a single scan function.

TABLE 38. SCAN ALL FUNCTION TIMING – DAISY CHAIN MASTER OR STANDALONE DEVICE

EVENT	ELAPSED TIME (ms)	
	TYP	MAX
Start Scan Voltages	0	0
Start Scan Wires	0.8	0.9
Start Scan Temperatures	60.1	66.2
Complete Sequence	62.8	69.1

MEASURE COMMAND

Single parameter measurements of the cell voltages, Pack Voltage, ExT1 to ExT4 inputs, IC temperature and Reference voltage are performed using the Measure command.

TABLE 39. VARIOUS MEASURE FUNCTION TIMINGS – DAISY CHAIN MASTER OR STANDALONE DEVICE

EVENT	ELAPSED TIME (μs)	
	TYP	MAX
Measure Cell Voltage	178	196
Measure Pack Voltage	122	134
Measure ExT Input	2517	2768
Measure IC Temperature	106	116
Measure Reference Voltage	106	116

Command Timing Tables

The command timing tables (see [Tables 40](#) and [41](#)) include the time from the start of the command to the start of an internal operation and the time required for the communication to complete (since the internal operation begins before the end of the daisy chain command.)

In the case of a command that starts a scan or measurement, the host needs to wait until the command completes, by reaching the last device, plus a communications wait time (see [Table 33](#)) before sending another command. For a Read command, the response begins in the top device immediately following the end of the command.

In calculating overall timing, use the time for each target device command. This time is repeated for each device in the daisy chain, except when an "Address All" option is used. In an address all operation, use the command timing for the top device in the stack to determine when the command ends, but use the time to start of scan for each device to determine when that device begins its internal voltage sampling. For example, in a stack of six devices, it takes 86.9μs for the command to complete, but internal operations start at 7.8μs for the Master, 66.7μs for device 2, 68.9μs for device 3, etc.

In [Tables 40](#) and [41](#), the calculation assumes a daisy chain (and internal) clock that is 10% slower than the nominal and an SPI clock that is running at the nominal speed (since the SPI clock is normally crystal controlled.) For the 500kHz Daisy setting, timing assumes a 450kHz clock.

TABLE 40. MAXIMUM COMMAND TIMING
(DAISY CLOCK = 500kHz, SPI CLOCK = 2MHz)

TARGET DEVICE	TIME TO START OF SCAN FOR TARGET DEVICE (μs)	COMMAND TIME TO START OF RESPONSE (DAISY) (μs)
1	13.8	
2	68.7	80.1
3	70.9	82.3
4	73.2	84.5
5	75.4	86.7
6	77.6	88.9
7	79.8	91.2
8	82.1	93.4
9	84.3	95.6
10	86.5	97.8
11	88.7	100.1
12	90.9	102.3
13	93.2	104.5
14	95.4	106.7

TABLE 41. MAXIMUM COMMAND TIMING
(DAISY CLOCK = 250kHz, SPI CLOCK = 2MHz)

TARGET DEVICE	TIME TO START OF SCAN FOR TARGET DEVICE (μs)	COMMAND TIME TO START OF RESPONSE (DAISY) (μs)
1	13.8	
2	130.9	155.6
3	135.4	160.1
4	139.8	164.5
5	144.3	168.9
6	148.7	173.4
7	153.2	177.8
8	157.6	182.3
9	162.1	186.7
10	166.5	191.2
11	170.9	195.6
12	175.4	200.1
13	179.8	204.5
14	184.3	208.9

Response Timing Tables

Response timing depends on the number of devices in the stack, the position of the device in the stack, and how many bytes are read back. There are four "sizes" of read responses that are as follows:

- Single register read or ACK/NAK responses, where four bytes are returned by the Read Command
- Read all voltage response, which returns 40 bytes
- Read all temps or read all faults responses, which returns 22 bytes
- Read all setup registers response, which returns 43 bytes

In the following tables, the Master, Middle and Top device response times for any number of daisy chain devices are included with the command timing for that configuration. The right hand column shows the total time to complete the read operation. This is calculated by [Equation 4](#):

$$(N \times T_{\text{COMMAND}}) + ((N - 2) \times T_{\text{MID}}) + T_{\text{TOP}} + T_{\text{MASTER}} \quad (\text{EQ. 4})$$

Where N = Number of devices in the stack.

In the following tables, internal and daisy clocks are assumed to be slow by 10% and the SPI clock is assumed to be at the stated speed.

For an example, consider a stack of 6 devices. To get the full scan time with a daisy clock of 500kHz and SPI clock of 2MHz, it takes 77.6μs from the start of the Scan All command to the start of the internal scan (see [Table 40](#)), 842μs to complete a scan of all voltages (see [Table 34 on page 56](#)), 5.334ms to read all cell voltages from all devices (see [Table 44 on page 60](#)) and 18μs delay before issuing another command. In this case, all cell voltages in the host controller can be updated every 6.28ms.

4-BYTE RESPONSE

Tables 42 and 43 show the calculated timing for read operations for 4 byte responses. This is the timing for an ACK or NAK, as well as Read Register command.

TABLE 42. READ TIMING (MAX): 4-BYTE RESPONSE, DAISY CLOCK = 500kHz, SPI CLOCK = 2MHz

TOP STACK DEVICE	COMMAND TIME TO START OF RESPONSE (EACH DAISY DEVICE) (μs)	MASTER RESPONSE TIME TO COMPLETE RESPONSE (DAISY) (μs)	MIDDLE RESPONSE TIME TO COMPLETE RESPONSE (EACH MID DAISY DEVICE) (μs)	TOP RESPONSE TIME TO COMPLETE RESPONSE (DAISY) (μs)	RESPONSE ALL DEVICES (μs)	COMMAND + RESPONSE ALL DEVICES (μs)
2	80	139		110	250	410
3	82	142	201	113	455	702
4	85	144	203	115	666	1004
5	87	146	206	117	880	1314
6	89	148	208	119	1099	1633
7	91	151	210	121	1323	1961
8	93	153	212	124	1550	2298
9	96	155	215	126	1783	2643
10	98	157	217	128	2020	2998
11	100	159	219	130	2261	3361
12	102	162	221	133	2506	3734
13	105	164	223	135	2757	4115
14	107	166	226	137	3011	4505

TABLE 43. READ TIMING (MAX): 4-BYTE RESPONSE, DAISY CLOCK = 250kHz, SPI CLOCK = 2MHz

TOP STACK DEVICE	COMMAND TIME TO START OF RESPONSE (EACH DAISY DEVICE) (μs)	MASTER RESPONSE TIME TO COMPLETE RESPONSE (DAISY) (μs)	MIDDLE RESPONSE TIME TO COMPLETE RESPONSE (EACH MID DAISY DEVICE) (μs)	TOP RESPONSE TIME TO COMPLETE RESPONSE (DAISY) (μs)	RESPONSE ALL DEVICES (μs)	COMMAND + RESPONSE ALL DEVICES (μs)
2	156	228		204	432	743
3	160	233	383	208	824	1304
4	165	237	388	213	1226	1884
5	169	242	392	217	1636	2480
6	173	246	397	221	2055	3095
7	178	251	401	226	2483	3727
8	182	255	406	230	2919	4378
9	187	259	410	235	3365	5045
10	191	264	415	239	3820	5731
11	196	268	419	244	4283	6435
12	200	273	423	248	4755	7156
13	205	277	428	253	5237	7895
14	209	282	432	257	5727	8652

40-BYTE RESPONSE

Tables 44 and 45 show the calculated timing for read operations for 40-byte responses. Specifically, this is the timing for a Read All Voltages command.

TABLE 44. READ TIMING (MAX): 40-BYTE RESPONSE, DAISY CLOCK = 500kHz, SPI CLOCK = 2MHz

TOP STACK DEVICE	COMMAND TIME TO START OF RESPONSE (EACH DAISY DEVICE) (μs)	MASTER RESPONSE TIME TO COMPLETE RESPONSE (DAISY) (μs)	MIDDLE RESPONSE TIME TO COMPLETE RESPONSE (EACH MID DAISY DEVICE) (μs)	TOP RESPONSE TIME TO COMPLETE RESPONSE (DAISY) (μs)	RESPONSE ALL DEVICES (μs)	COMMAND + RESPONSE ALL DEVICES (μs)
2	80	643		750	1394	1554
3	82	646	841	753	2239	2486
4	85	648	843	755	3090	3428
5	87	650	846	757	3944	4378
6	89	652	848	759	4803	5337
7	91	655	850	761	5667	6305
8	93	657	852	764	6534	7282
9	96	659	855	766	7407	8267
10	98	661	857	768	8284	9262
11	100	663	859	770	9165	10265
12	102	666	861	773	10050	11278
13	105	668	863	775	10941	12299
14	107	670	866	777	11835	13329

TABLE 45. READ TIMING (MAX): 40-BYTE RESPONSE, DAISY CLOCK = 250kHz, SPI CLOCK = 2MHz

TOP STACK DEVICE	COMMAND TIME TO START OF RESPONSE (EACH DAISY DEVICE) (μs)	MASTER RESPONSE TIME TO COMPLETE RESPONSE (DAISY) (μs)	MIDDLE RESPONSE TIME TO COMPLETE RESPONSE (EACH MID DAISY DEVICE) (μs)	TOP RESPONSE TIME TO COMPLETE RESPONSE (DAISY) (μs)	RESPONSE ALL DEVICES (μs)	COMMAND + RESPONSE ALL DEVICES (μs)
2	156	732		1484	2216	2527
3	160	737	1663	1488	3888	4368
4	165	741	1668	1493	5570	6228
5	169	746	1672	1497	7260	8104
6	173	750	1677	1501	8959	9999
7	178	755	1681	1506	10667	11911
8	182	759	1686	1510	12383	13842
9	187	763	1690	1515	14109	15789
10	191	768	1695	1519	15844	17755
11	196	772	1699	1524	17587	19739
12	200	777	1703	1528	19339	21740
13	205	781	1708	1533	21101	23759
14	209	786	1712	1537	22871	25796

22-BYTE RESPONSE

Tables 46 and 47 show the calculated timing of read operations for 22-byte responses. This is the timing for Read All Temperature or Read All Faults command.

TABLE 46. READ TIMING (MAX): 22-BYTE RESPONSE, DAISY CLOCK = 500kHz, SPI CLOCK = 2MHz

TOP STACK DEVICE	COMMAND TIME TO START OF RESPONSE (EACH DAISY DEVICE) (μs)	MASTER RESPONSE TIME TO COMPLETE RESPONSE (DAISY) (μs)	MIDDLE RESPONSE TIME TO COMPLETE RESPONSE (EACH MID DAISY DEVICE) (μs)	TOP RESPONSE TIME TO COMPLETE RESPONSE (DAISY) (μs)	RESPONSE ALL DEVICES (μs)	COMMAND + RESPONSE ALL DEVICES (μs)
2	80	391		430	822	982
3	82	394	521	433	1347	1594
4	85	396	523	435	1878	2216
5	87	398	526	437	2412	2846
6	89	400	528	439	2951	3485
7	91	403	530	441	3495	4133
8	93	405	532	444	4042	4790
9	96	407	535	446	4595	5455
10	98	409	537	448	5152	6130
11	100	411	539	450	5713	6813
12	102	414	541	453	6278	7506
13	105	416	543	455	6849	8207
14	107	418	546	457	7423	8917

TABLE 47. READ TIMING (MAX): 22-BYTE RESPONSE, DAISY CLOCK = 250kHz, SPI CLOCK = 2MHz

TOP STACK DEVICE	COMMAND TIME TO START OF RESPONSE (EACH DAISY DEVICE) (μs)	MASTER RESPONSE TIME TO COMPLETE RESPONSE (DAISY) (μs)	MIDDLE RESPONSE TIME TO COMPLETE RESPONSE (EACH MID DAISY DEVICE) (μs)	TOP RESPONSE TIME TO COMPLETE RESPONSE (DAISY) (μs)	RESPONSE ALL DEVICES (μs)	COMMAND + RESPONSE ALL DEVICES (μs)
2	156	480		844	1324	1635
3	160	485	1023	848	2356	2836
4	165	489	1028	853	3398	4056
5	169	494	1032	857	4448	5292
6	173	498	1037	861	5507	6547
7	178	503	1041	866	6575	7819
8	182	507	1046	870	7651	9110
9	187	511	1050	875	8737	10417
10	191	516	1055	879	9832	11743
11	196	520	1059	884	10935	13087
12	200	525	1063	888	12047	14448
13	205	529	1068	893	13169	15827
14	209	534	1072	897	14299	17224

System Registers

System registers contain 14-bits each. All register locations are memory mapped using a 9-bit address. The MSBs of the address form a 3-bit page address. Page 1 (3'b001) registers are the measurement result registers for cell voltages and temperatures. Page 3 (3'b011) is used for commands. Pages 1 and 3 are not subject to the checksum calculations. Page addresses 4 and 5 (3'b100 and 3'b101), with the exception of the EEPROM checksum registers, are reserved for internal functions.

All page 2 registers (device configuration registers), together with the EEPROM checksum registers, are subject to a checksum calculation. The checksum is calculated in response to the Calculate Register Checksum command using a Multiple Input Shift Register (MISR) error detection technique. The checksum is tested in response to a Check Register Checksum command. The occurrence of a checksum error sets the PAR bit in the Fault

Status register and causes a Fault response accordingly. The normal response to a PAR error is for the host microcontroller to re-write the page 2 register contents. A PAR fault also causes the device to cease any scanning or cell balancing activity.

A description of each register is included in “[Register Descriptions](#)” as follows and includes a depiction of the register with bit names and initialization values at power-up, when the EN pin is toggled and the device receives a Reset Command, or when the device is reset. Bits which reflect the state of external pins are notated “Pin” in the initialization space. Bits which reflect the state of nonvolatile memory bits (EEPROM) are notated “NV” in the initialization space. Initialization values are shown below each bit name.

Reserved bits (indicated by grey areas) should be ignored when reading and should be set to “0” when writing to them.

Register Descriptions

Cell Voltage Data

BASE ADDR (PAGE)	ACCESS	ADDRESS RANGE	DESCRIPTION
3'b001	Read Only	6'h00 - 6'h0C and 6'h0F	Measured cell voltage and pack voltage values. Address 001111 accesses all cell and Pack Voltage data with one read operation. See Figure 41D on page 40 . Cell and Pack Voltage values are output as 13-bit signed integers with the 14 th bit (MSB) denoting the sign, (e.g., positive full scale is 14'h1FFF, 8191 decimal, negative full scale is 14'h2000, 8192 decimal).

ACCESS	PAGE ADDR	REGISTER ADDRESS	DESCRIPTION	
Read Only	3'b001	6'h00	$\text{if...HEXvalue}_{10} \geq 8191 \rightarrow \text{VBAT} = \frac{(\text{HEXvalue}_{10} - 16384) \times 15.9350784 \times 2.5}{8192}$ $\text{VCx} = \frac{(\text{HEXvalue}_{10} - 16384) \times 2 \times 2.5}{8192}$ $\text{else} \rightarrow \text{VBAT} = \frac{\text{HEXvalue}_{10} \times 15.9350784 \times 2.5}{8192}$ $\text{VCx} = \frac{\text{HEXvalue}_{10} \times 2 \times 2.5}{8192}$	
		6'h01		VBAT Voltage
		6'h02		Cell 1 Voltage
		6'h03		Cell 2 Voltage
		6'h04		Cell 3 Voltage
		6'h05		Cell 4 Voltage
		6'h06		Cell 5 Voltage
		6'h07		Cell 6 Voltage
		6'h08		Cell 7 Voltage
		6'h09		Cell 8 Voltage
		6'h0A		Cell 9 Voltage
		6'h0B		Cell 10 Voltage
		6'h0C		Cell 11 Voltage
6'h0F	Read all cell voltages			

Temperature Data, Secondary Voltage Reference Data, Scan Count

BASE ADDR (PAGE)	ACCESS	ADDRESS RANGE	DESCRIPTION
3'b001	See individual register	6'h10 - 6'h16 and 6'h1F	Measured temperature, Secondary reference, Scan Count. Address 011111 accesses all these data in a continuous read (see Figure 41D on page 40 .) Temperature and reference values are output as 14-bit unsigned integers, (e.g., full scale is 14'h3FFF (16383 decimal)). $V_{\text{temp}} = \frac{\text{HEXvalue}_{10} \times 2.5}{16384}$

ACCESS	PAGE ADDR	REGISTER ADDRESS	DESCRIPTION																																										
Read Only	3'b001	6'h10	Internal temperature reading.																																										
		6'h11	External temperature input 1 reading.																																										
		6'h12	External temperature input 2 reading.																																										
		6'h13	External temperature input 3 reading.																																										
		6'h14	External temperature input 4 reading.																																										
		6'h15	Reference voltage (raw ADC) value. Use to calculate corrected reference value using reference coefficient data. See page 2 data, address 6'h38 - 6'h3A.																																										
Read/Write	3'h001	6'h16	Scan Count: Current scan instruction count. Count is incremented each time a scan command is received and wraps to zero when overflowed. Register may be compared to previous value to confirm scan command receipt. Bit Designations:																																										
			<table border="1"> <tr> <td>13</td><td>12</td><td>11</td><td>10</td><td>9</td><td>8</td><td>7</td><td>6</td><td>5</td><td>4</td><td>3</td><td>2</td><td>1</td><td>0</td> </tr> <tr> <td colspan="10">RESERVED</td> <td>SCN3</td><td>SCN2</td><td>SCN1</td><td>SCN0</td> </tr> <tr> <td>0</td><td>0</td><td>0</td><td>0</td><td>0</td><td>0</td><td>0</td><td>0</td><td>0</td><td>0</td><td>0</td><td>0</td><td>0</td><td>0</td> </tr> </table>	13	12	11	10	9	8	7	6	5	4	3	2	1	0	RESERVED										SCN3	SCN2	SCN1	SCN0	0	0	0	0	0	0	0	0	0	0	0	0	0	0
			13	12	11	10	9	8	7	6	5	4	3	2	1	0																													
RESERVED										SCN3	SCN2	SCN1	SCN0																																
0	0	0	0	0	0	0	0	0	0	0	0	0	0																																
0	0	0	0	0	0	0	0	0	0	0	0	0	0																																
Read Only	3'h001	6'h1F	Read all: Temperature Data, Secondary Voltage Reference Data, Scan Count (locations 6'h10 - 6'h16)																																										

Fault Registers

BASE ADDR (PAGE)	ACCESS	ADDRESS RANGE	DESCRIPTION
3'h010	Read/Write	6'h00 - 6'h05 and 6'h0F	Fault registers. Fault setup and status information. Address 6'h0F accesses all fault data in a continuous read (Daisy Chain configuration only). See Figure 41D on page 40 .

ACCESS	PAGE ADDR	REGISTER ADDRESS	DESCRIPTION																																										
Read/Write	3'h010	6'h00	Overvoltage Fault: Overvoltage fault on cells 12 to 1 correspond with bits OF12 to OF1, respectively. Default values are all zero. Bits are set to 1 when faults are detected. The contents of this register may be reset via register write (14'h0000).																																										
			<table border="1"> <tr> <td>13</td><td>12</td><td>11</td><td>10</td><td>9</td><td>8</td><td>7</td><td>6</td><td>5</td><td>4</td><td>3</td><td>2</td><td>1</td><td>0</td> </tr> <tr> <td colspan="2">RESERVED</td><td>OF12</td><td>OF11</td><td>OF10</td><td>OF9</td><td>OF8</td><td>OF7</td><td>OF6</td><td>OF5</td><td>OF4</td><td>OF3</td><td>OF2</td><td>OF1</td> </tr> <tr> <td>0</td><td>0</td><td>0</td><td>0</td><td>0</td><td>0</td><td>0</td><td>0</td><td>0</td><td>0</td><td>0</td><td>0</td><td>0</td><td>0</td> </tr> </table>	13	12	11	10	9	8	7	6	5	4	3	2	1	0	RESERVED		OF12	OF11	OF10	OF9	OF8	OF7	OF6	OF5	OF4	OF3	OF2	OF1	0	0	0	0	0	0	0	0	0	0	0	0	0	0
			13	12	11	10	9	8	7	6	5	4	3	2	1	0																													
RESERVED		OF12	OF11	OF10	OF9	OF8	OF7	OF6	OF5	OF4	OF3	OF2	OF1																																
0	0	0	0	0	0	0	0	0	0	0	0	0	0																																
0	0	0	0	0	0	0	0	0	0	0	0	0	0																																
Read/Write	3'h010	6'h01	Undervoltage Fault: Undervoltage fault on cells 12 to 1 correspond with bits UF12 to UF1, respectively. Default values are all zero. Bits are set to 1 when faults are detected. The contents of this register may be reset via register write (14'h0000).																																										
			<table border="1"> <tr> <td>13</td><td>12</td><td>11</td><td>10</td><td>9</td><td>8</td><td>7</td><td>6</td><td>5</td><td>4</td><td>3</td><td>2</td><td>1</td><td>0</td> </tr> <tr> <td colspan="2">RESERVED</td><td>UF12</td><td>UF11</td><td>UF10</td><td>UF9</td><td>UF8</td><td>UF7</td><td>UF6</td><td>UF5</td><td>UF4</td><td>UF3</td><td>UF2</td><td>UF1</td> </tr> <tr> <td>0</td><td>0</td><td>0</td><td>0</td><td>0</td><td>0</td><td>0</td><td>0</td><td>0</td><td>0</td><td>0</td><td>0</td><td>0</td><td>0</td> </tr> </table>	13	12	11	10	9	8	7	6	5	4	3	2	1	0	RESERVED		UF12	UF11	UF10	UF9	UF8	UF7	UF6	UF5	UF4	UF3	UF2	UF1	0	0	0	0	0	0	0	0	0	0	0	0	0	0
			13	12	11	10	9	8	7	6	5	4	3	2	1	0																													
RESERVED		UF12	UF11	UF10	UF9	UF8	UF7	UF6	UF5	UF4	UF3	UF2	UF1																																
0	0	0	0	0	0	0	0	0	0	0	0	0	0																																
0	0	0	0	0	0	0	0	0	0	0	0	0	0																																
Read/Write	3'h010	6'h02	Open Wire Fault: Open Wire fault on Pins VC12 to VC0 correspond with bits OC12 to OC0, respectively. Default values are all zero. Bits are set to 1 when faults are detected. The contents of this register may be reset via register write (14'h0000).																																										
			<table border="1"> <tr> <td>13</td><td>12</td><td>11</td><td>10</td><td>9</td><td>8</td><td>7</td><td>6</td><td>5</td><td>4</td><td>3</td><td>2</td><td>1</td><td>0</td> </tr> <tr> <td>RESERVED</td><td>OC12</td><td>OC11</td><td>OC10</td><td>OC9</td><td>OC8</td><td>OC7</td><td>OC6</td><td>OC5</td><td>OC4</td><td>OC3</td><td>OC2</td><td>OC1</td><td>OC0</td> </tr> <tr> <td>0</td><td>0</td><td>0</td><td>0</td><td>0</td><td>0</td><td>0</td><td>0</td><td>0</td><td>0</td><td>0</td><td>0</td><td>0</td><td>0</td> </tr> </table>	13	12	11	10	9	8	7	6	5	4	3	2	1	0	RESERVED	OC12	OC11	OC10	OC9	OC8	OC7	OC6	OC5	OC4	OC3	OC2	OC1	OC0	0	0	0	0	0	0	0	0	0	0	0	0	0	0
			13	12	11	10	9	8	7	6	5	4	3	2	1	0																													
RESERVED	OC12	OC11	OC10	OC9	OC8	OC7	OC6	OC5	OC4	OC3	OC2	OC1	OC0																																
0	0	0	0	0	0	0	0	0	0	0	0	0	0																																
0	0	0	0	0	0	0	0	0	0	0	0	0	0																																

ACCESS	PAGE ADDR	REGISTER ADDRESS	DESCRIPTION																																										
Read/ Write	3'h010	6'h03	Fault Setup: These bits control various Fault configurations. Default values are shown below, as are descriptions of each bit.																																										
			<table border="1"> <thead> <tr> <th>13</th> <th>12</th> <th>11</th> <th>10</th> <th>9</th> <th>8</th> <th>7</th> <th>6</th> <th>5</th> <th>4</th> <th>3</th> <th>2</th> <th>1</th> <th>0</th> </tr> </thead> <tbody> <tr> <td>RESER VED</td> <td>TST4</td> <td>TST3</td> <td>TST2</td> <td>TST1</td> <td>TST0</td> <td>TOT2</td> <td>TOT1</td> <td>TOTO</td> <td>WSCN</td> <td>SCN3</td> <td>SCN2</td> <td>SCN1</td> <td>SCN0</td> </tr> <tr> <td>0</td> <td>0</td> <td>0</td> <td>0</td> <td>1</td> <td>0</td> <td>0</td> <td>1</td> <td>1</td> <td>1</td> <td>0</td> <td>0</td> <td>0</td> <td>0</td> </tr> </tbody> </table>	13	12	11	10	9	8	7	6	5	4	3	2	1	0	RESER VED	TST4	TST3	TST2	TST1	TST0	TOT2	TOT1	TOTO	WSCN	SCN3	SCN2	SCN1	SCN0	0	0	0	0	1	0	0	1	1	1	0	0	0	0
			13	12	11	10	9	8	7	6	5	4	3	2	1	0																													
			RESER VED	TST4	TST3	TST2	TST1	TST0	TOT2	TOT1	TOTO	WSCN	SCN3	SCN2	SCN1	SCN0																													
			0	0	0	0	1	0	0	1	1	1	0	0	0	0																													
			SCNO, 1, 2, 3 Scan interval code. Decoded to provide the scan interval setup for the auto scan function. Initialized to 0000 (16ms scan interval). See Table 2 on page 23 .																																										
			WSCN Scan wires timing control. Set to 1 for tracking of the temperature scan interval. Set to 0 for tracking of the cell voltage scan interval above 512ms. Interval is fixed at 512ms for faster cell scan rates. See Table 2 on page 23 .																																										
			TOTO, 1, 2 Fault totalize code bits. Decoded to provide the required fault totalization. An unbroken sequence of positive fault results equal to the totalize amount is needed to verify a fault condition. Initialized to 011 (8 sample totalizing.) See Table 29 on page 46 . This register must be re-written following an error detection resulting from totalizer overflow.																																										
TST0 Controls temperature testing of internal IC temperature. Set bit to 1 to enable internal temperature test. Set to 0 to disable (not recommended). Initialized to 1 (on).																																													
TST1 to TST4 Controls temperature testing on the external temperature inputs 1 to 4, respectively. Set bit to 1 to enable the corresponding temperature test. Set to 0 to disable. Allows external inputs to be used for general voltage monitoring without imposing a limit value. TST1 to TST4 are initialized to 0 (off).																																													

ACCESS	PAGE ADDR	REGISTER ADDRESS	DESCRIPTION																																										
Read/ Write	3'h010	6'h04	<p>Fault Status: The FAULT logic output is an OR function of the bits in this register: the output will be asserted low if any bits in the Fault Status register are set.</p> <table border="1"> <thead> <tr> <th>13</th><th>12</th><th>11</th><th>10</th><th>9</th><th>8</th><th>7</th><th>6</th><th>5</th><th>4</th><th>3</th><th>2</th><th>1</th><th>0</th> </tr> </thead> <tbody> <tr> <td>MUX</td><td>REG</td><td>REF</td><td>PAR</td><td>OVSS</td><td>OV_{BAT}</td><td>OW</td><td>UV</td><td>OV</td><td>OT</td><td>WDGF</td><td>OSC</td><td colspan="2">RESERVED</td> </tr> <tr> <td>0</td><td>0</td><td>0</td><td>0</td><td>0</td><td>0</td><td>0</td><td>0</td><td>0</td><td>0</td><td>0</td><td>0</td><td>0</td><td>0</td> </tr> </tbody> </table>	13	12	11	10	9	8	7	6	5	4	3	2	1	0	MUX	REG	REF	PAR	OVSS	OV _{BAT}	OW	UV	OV	OT	WDGF	OSC	RESERVED		0	0	0	0	0	0	0	0	0	0	0	0	0	0
			13	12	11	10	9	8	7	6	5	4	3	2	1	0																													
			MUX	REG	REF	PAR	OVSS	OV _{BAT}	OW	UV	OV	OT	WDGF	OSC	RESERVED																														
			0	0	0	0	0	0	0	0	0	0	0	0	0	0																													
			OSC	Oscillator fault bit. Bit is set in response to a fault on either the 4MHz or 32kHz oscillators. Note that communications functions may be disrupted by a fault in the 4MHz oscillator.																																									
			WDGF	Watchdog timeout fault. Bit is set in response to a watchdog timeout.																																									
			OT	Over-temperature fault. 'OR' of over-temperature fault bits: TFLT0 to TFLT4. This bit is latched. The bits in the Over-temperature Fault register must first be reset before this bit can be reset. Reset by writing 14'h0000 to this register.																																									
			OV	Overvoltage fault. 'OR' of Overvoltage fault bits: OF1 to OF12. This bit is latched. The bits in the Overvoltage Fault register must first be reset before this bit can be reset. Reset by writing 14'h0000 to this register.																																									
			UV	Undervoltage fault. 'OR' of Undervoltage fault bits: UF1 to UF12. This bit is latched. The bits in the Undervoltage Fault register must first be reset before this bit can be reset. Reset by writing 14'h0000 to this register.																																									
			OW	Open Wire fault. 'OR' of open wire fault bits: OCO to OC12. This bit is latched. The bits in the Open Wire Fault register must first be reset before this bit can be reset. Reset by writing 14'h0000 to this register.																																									
			OV _{BAT}	Open wire fault on V_{BAT} connection. Bit set to 1 when a fault is detected. May be reset via register write (14'h0000).																																									
			OVSS	Open wire fault on VSS connection. Bit set to 1 when a fault is detected. May be reset via register write (14'h0000).																																									
			PAR	Register checksum (Parity) error. This bit is set in response to a register checksum error. The checksum is calculated and stored in response to a Calc Register Checksum command and acts on the contents of all page 2 registers. The Check Register Checksum command is used to repeat the calculation and compare the results to the stored value. The PAR bit is then set if the two results are not equal. This bit is not set in response to a nonvolatile EEPROM memory checksum error. See table on page 71 .																																									
			REF	Voltage reference fault. This bit is set if the voltage reference value is outside its "power-good" range.																																									
REG	Voltage regulator fault. This bit is set if a voltage regulator value (V3P3, VCC or V2P5) is outside its "power-good" range.																																												
MUX	Temperature multiplexer error. This bit is set if the VCC loopback check returns a fault. The VCC loopback check is performed at the end of each temperature scan.																																												
Read/ Write	3'h010	6'h05	<p>Cell Setup: Default values are shown below, as are descriptions of each bit.</p> <table border="1"> <thead> <tr> <th>13</th><th>12</th><th>11</th><th>10</th><th>9</th><th>8</th><th>7</th><th>6</th><th>5</th><th>4</th><th>3</th><th>2</th><th>1</th><th>0</th> </tr> </thead> <tbody> <tr> <td>FFSN</td><td>FFSP</td><td>C12</td><td>C11</td><td>C10</td><td>C9</td><td>C8</td><td>C7</td><td>C6</td><td>C5</td><td>C4</td><td>C3</td><td>C2</td><td>C1</td> </tr> <tr> <td>0</td><td>0</td><td>0</td><td>0</td><td>0</td><td>0</td><td>0</td><td>0</td><td>0</td><td>0</td><td>0</td><td>0</td><td>0</td><td>0</td> </tr> </tbody> </table>	13	12	11	10	9	8	7	6	5	4	3	2	1	0	FFSN	FFSP	C12	C11	C10	C9	C8	C7	C6	C5	C4	C3	C2	C1	0	0	0	0	0	0	0	0	0	0	0	0	0	0
			13	12	11	10	9	8	7	6	5	4	3	2	1	0																													
			FFSN	FFSP	C12	C11	C10	C9	C8	C7	C6	C5	C4	C3	C2	C1																													
			0	0	0	0	0	0	0	0	0	0	0	0	0	0																													
			C1 to C12	Enable/disable cell overvoltage, undervoltage and open wire detection on cell 1 to 12, respectively. Set to 1 to disable OV/UV and open wire tests.																																									
			FFSP	Force ADC input to Full Scale Positive. All cell scan readings forced to 14'h1FFF. All temperature scan readings forced to 14'h3FFF.																																									
			FFSN	Force ADC input to Full Scale Negative. All cell scan readings forced to 14'h2000. All temperature scan readings forced to 14'h0000.																																									
			NOTE: The ADC input functions normally if both FFSN and FFSP are set to '1' but this setting is not supported.																																										

ACCESS	PAGE ADDR	REGISTER ADDRESS	DESCRIPTION																																										
Read/ Write	3'h010	6'h06	Over-temperature Fault: Over-temperature fault on cells 12 to 1 correspond with bits OF12 to OF1, respectively. Default values are all zero. Bits are set to 1 when fault are detected. The contents of this register may be reset via register write (14'h0000).																																										
			<table border="1"> <tr> <td>13</td><td>12</td><td>11</td><td>10</td><td>9</td><td>8</td><td>7</td><td>6</td><td>5</td><td>4</td><td>3</td><td>2</td><td>1</td><td>0</td> </tr> <tr> <td colspan="9">RESERVED</td> <td>TFLT4</td><td>TFLT3</td><td>TFLT2</td><td>TFLT1</td><td>TFLT0</td> </tr> <tr> <td>0</td><td>0</td><td>0</td><td>0</td><td>0</td><td>0</td><td>0</td><td>0</td><td>0</td><td>0</td><td>0</td><td>0</td><td>0</td><td>0</td> </tr> </table>	13	12	11	10	9	8	7	6	5	4	3	2	1	0	RESERVED									TFLT4	TFLT3	TFLT2	TFLT1	TFLT0	0	0	0	0	0	0	0	0	0	0	0	0	0	0
			13	12	11	10	9	8	7	6	5	4	3	2	1	0																													
			RESERVED									TFLT4	TFLT3	TFLT2	TFLT1	TFLT0																													
			0	0	0	0	0	0	0	0	0	0	0	0	0	0																													
TFLT0	Internal over-temperature fault. Bit set to 1 when a fault is detected. May be reset via register write (14'h0000).																																												
TFLT1 - TFLT4	External over-temperature inputs 1 to 4 (respectively.) Bit set to 1 when a fault is detected. May be reset via register write (14'h0000).																																												
Read Only	3'h010	6'h0F	Read all Fault and Cell Setup data from locations: 6'h00 - 6'h06. See Figure 41D on page 40 .																																										

Setup Registers

BASE ADDR (PAGE)	Access	ADDRESS RANGE	DESCRIPTION
3'b010		6'h10 - 6'h1D and 6'h1F	Device Setup registers. All device setup data.

ACCESS	PAGE ADDR	REGISTER ADDRESS	DESCRIPTION																																										
Read/ Write	3'b010	6'h10	Overvoltage Limit: Overvoltage Limit Value Overvoltage limit is compared to the measured values for cells 1 to 12 to test for an Overvoltage condition at any of the cells. Bit 0 is the LSB, Bit 12 is the MSB. Bit 13 is not used and must be set to 0.																																										
			<table border="1"> <tr> <td>13</td><td>12</td><td>11</td><td>10</td><td>9</td><td>8</td><td>7</td><td>6</td><td>5</td><td>4</td><td>3</td><td>2</td><td>1</td><td>0</td> </tr> <tr> <td>RESER VED</td><td>OV12</td><td>OV11</td><td>OV10</td><td>OV9</td><td>OV8</td><td>OV7</td><td>OV6</td><td>OV5</td><td>OV4</td><td>OV3</td><td>OV2</td><td>OV1</td><td>OV0</td> </tr> <tr> <td>0</td><td>1</td><td>1</td><td>1</td><td>1</td><td>1</td><td>1</td><td>1</td><td>1</td><td>1</td><td>1</td><td>1</td><td>1</td><td>1</td> </tr> </table>	13	12	11	10	9	8	7	6	5	4	3	2	1	0	RESER VED	OV12	OV11	OV10	OV9	OV8	OV7	OV6	OV5	OV4	OV3	OV2	OV1	OV0	0	1	1	1	1	1	1	1	1	1	1	1	1	1
			13	12	11	10	9	8	7	6	5	4	3	2	1	0																													
			RESER VED	OV12	OV11	OV10	OV9	OV8	OV7	OV6	OV5	OV4	OV3	OV2	OV1	OV0																													
0	1	1	1	1	1	1	1	1	1	1	1	1	1																																
TFLT0	Internal over-temperature fault. Bit set to 1 when a fault is detected. May be reset via register write (14'h0000).																																												
TFLT1 - TFLT4	External over-temperature inputs 1 to 4 (respectively.) Bit set to 1 when a fault is detected. May be reset via register write (14'h0000).																																												
Read/ Write	3'b010	6'h11	Undervoltage Limit: Undervoltage Limit Value Undervoltage limit is compared to the measured values for cells 1 to 12 to test for an undervoltage condition at any of the cells. Bit 0 is the LSB, Bit 12 is the MSB. Bit 13 is not used and must be set to 0.																																										
			<table border="1"> <tr> <td>13</td><td>12</td><td>11</td><td>10</td><td>9</td><td>8</td><td>7</td><td>6</td><td>5</td><td>4</td><td>3</td><td>2</td><td>1</td><td>0</td> </tr> <tr> <td>RESER VED</td><td>UV12</td><td>UV11</td><td>UV10</td><td>UV9</td><td>UV8</td><td>UV7</td><td>UV6</td><td>UV5</td><td>UV4</td><td>UV3</td><td>UV2</td><td>UV1</td><td>UV0</td> </tr> <tr> <td>0</td><td>0</td><td>0</td><td>0</td><td>0</td><td>0</td><td>0</td><td>0</td><td>0</td><td>0</td><td>0</td><td>0</td><td>0</td><td>0</td> </tr> </table>	13	12	11	10	9	8	7	6	5	4	3	2	1	0	RESER VED	UV12	UV11	UV10	UV9	UV8	UV7	UV6	UV5	UV4	UV3	UV2	UV1	UV0	0	0	0	0	0	0	0	0	0	0	0	0	0	0
			13	12	11	10	9	8	7	6	5	4	3	2	1	0																													
			RESER VED	UV12	UV11	UV10	UV9	UV8	UV7	UV6	UV5	UV4	UV3	UV2	UV1	UV0																													
0	0	0	0	0	0	0	0	0	0	0	0	0	0																																
TFLT0	Internal over-temperature fault. Bit set to 1 when a fault is detected. May be reset via register write (14'h0000).																																												
TFLT1 - TFLT4	External over-temperature inputs 1 to 4 (respectively.) Bit set to 1 when a fault is detected. May be reset via register write (14'h0000).																																												
Read/ Write	3'b010	6'h12	External Temperature Limit: Over-temperature limit value Over-temperature limit is compared to the measured values for external temperatures 1 to 4 to test for an over-temperature condition at any input. The temperature limit assumes NTC temperature measurement devices (i.e., an over-temperature condition is indicated by a temperature reading below the limit value). Bit 0 is the LSB, Bit 13 is the MSB.																																										
			<table border="1"> <tr> <td>13</td><td>12</td><td>11</td><td>10</td><td>9</td><td>8</td><td>7</td><td>6</td><td>5</td><td>4</td><td>3</td><td>2</td><td>1</td><td>0</td> </tr> <tr> <td>ETL13</td><td>ETL12</td><td>ETL11</td><td>ETL10</td><td>ETL9</td><td>ETL8</td><td>ETL7</td><td>ETL6</td><td>ETL5</td><td>ETL4</td><td>ETL3</td><td>ETL2</td><td>ETL1</td><td>ETL0</td> </tr> <tr> <td>0</td><td>0</td><td>0</td><td>0</td><td>0</td><td>0</td><td>0</td><td>0</td><td>0</td><td>0</td><td>0</td><td>0</td><td>0</td><td>0</td> </tr> </table>	13	12	11	10	9	8	7	6	5	4	3	2	1	0	ETL13	ETL12	ETL11	ETL10	ETL9	ETL8	ETL7	ETL6	ETL5	ETL4	ETL3	ETL2	ETL1	ETL0	0	0	0	0	0	0	0	0	0	0	0	0	0	0
			13	12	11	10	9	8	7	6	5	4	3	2	1	0																													
			ETL13	ETL12	ETL11	ETL10	ETL9	ETL8	ETL7	ETL6	ETL5	ETL4	ETL3	ETL2	ETL1	ETL0																													
0	0	0	0	0	0	0	0	0	0	0	0	0	0																																
TFLT0	Internal over-temperature fault. Bit set to 1 when a fault is detected. May be reset via register write (14'h0000).																																												
TFLT1 - TFLT4	External over-temperature inputs 1 to 4 (respectively.) Bit set to 1 when a fault is detected. May be reset via register write (14'h0000).																																												

ACCESS	PAGE ADDR	REGISTER ADDRESS	DESCRIPTION														
Read/ Write	3'b010	6'h13	Balance Setup: Default values are shown below, as are descriptions of each bit.														
			13	12	11	10	9	8	7	6	5	4	3	2	1	0	
			RESERVED				BEN	BSP3	BSP2	BSP1	BSP0	BWT2	BWT1	BWT0	BMD1	BMD0	
			0	0	0	0	0	0	0	0	0	0	0	0	0	0	0
			BMD0, 1			Balance mode. These bits set balance mode.											
						BMD1	BMD0	Mode									
			0	0	OFF												
			0	1	Manual												
			1	0	Timed												
			1	1	Auto												
BWT0, 1, 2			Balance wait time. Register contents are decoded to provide the required wait time between device balancing. This is to assist with thermal management and is used with the Auto Balance mode . See Table 4 on page 25 .														
BSP0, 1, 2, 3			Balance Status register pointer. Points to one of the 13 incidents of the Balance Status register. Balance Status register 0 is used for Manual Balance mode and Timed Balance mode . Balance status registers 1 to 12 are used for Auto Balance mode . Balance status registers are accomplished by first configuring the Balance Status register pointer (e.g., to read (write) Balance Status register 5, load 0101 to the Balance Status register pointer, then read (write) to the Balance Status register). See Table 7 on page 26 .														
BEN			Balance enable. Set to '1' to enable balancing. '0' inhibits balancing. Setting or clearing this bit does not affect any other register contents. <i>Balance Enable</i> and Balance Inhibit commands are provided to allow control of this function without requiring a register write. These commands have the same effect as setting this bit directly. This bit is cleared automatically when balancing is complete and the <i>EOB</i> bit (see "6'h19" on page 68) is set.														
Read/ Write	3'b010	6'h14	Balance Status The Balance Status register is a Multiple Incidence register controlled by the BSP0-4 bits in the Balance Setup register. See Table 7 on page 26 . Bit 0 is the LSB, Bit 11 is the MSB.														
			13	12	11	10	9	8	7	6	5	4	3	2	1	0	
			RESERVED		BAL 12	BAL 11	BAL 10	BAL 8	BAL 8	BAL 7	BAL 6	BAL 5	BAL 4	BAL 3	BAL 2	BAL 1	
			0	0	0	0	0	0	0	0	0	0	0	0	0	0	0
BAL1 to BAL12			Cell 1 to Cell 12 balance control, respectively. A bit set to 1 enables balance control (turns FET on) of the corresponding cell. Writing this bit enables balance output for the current incidence of the Balance Status register for the cells corresponding to the particular bits, depending on the condition of <i>BEN</i> in the Balance Setup register. Read this bit to determine the current status of each cell's balance control.														
Read/ Write	3'b010	6'h15	Watchdog/Balance Time Defaults are shown below:														
			13	12	11	10	9	8	7	6	5	4	3	2	1	0	
			BTM6	BTM5	BTM4	BTM3	BTM2	BTM1	BTM0	WDG6	WDG5	WDG4	WDG3	WDG2	WDG1	WDG0	
			0	0	0	0	0	0	0	1	1	1	1	1	1	1	1
			WDG0 to WDG6			Watchdog timeout setting. Decoded to provide the time out value for the watchdog function. See "Watchdog Function" on page 43 for details. The watchdog may only be disabled (set to 7'h00) if the watchdog password is set. The watchdog setting can be changed to a nonzero value without writing to the watchdog password. See "Device Setup Register" on page 30 . Initialized to 7'h7F (128 minutes).											
BTM0 to BTM6			Balance timeout setting. Decoded to provide the time out value for Timed Balance mode and Auto Balance mode . Initialized to 7'00 (Disabled). See Table 9 on page 27 .														

ACCESS	PAGE ADDR	REGISTER ADDRESS	DESCRIPTION														
Read/Write	3'b010	6'h16 6'h17	User Register 28 bits of register space arranged as 2 x 14 bits available for user data. These registers have no effect on the operation of the ISL94212. These registers are included in the register checksum function.														
Read Only	3'b010	6'h18	Comms Setup														
			13	12	11	10	9	8	7	6	5	4	3	2	1	0	
			RESERVED	CRAT1	CRAT0	CSEL	CSEL	SIZE	SIZE	SIZE	SIZE	ADDR	ADDR	ADDR	ADDR	0	0
			0	0	COMS RATE1 pin	COMS RATE0 pin	COMS SEL2 pin	COMS SEL1 pin	0	0	0	0	0	0	0	0	0
			ADDR0-3		Device stack address. The stack address (device position in the stack) is determined automatically by the device in response to an "Identify" command. The resulting address is stored in ADDR0-3 and is used internally for communications paring and sequencing. The stack address may be read by the user but not written to.												
			SIZE0-3		Device stack size (top stack device address). Corresponds to the number of devices in the stack. The stack size is determined automatically by the stack devices in response to an "Identify" command. The resulting number is stored in SIZE0-3 and is used internally for communications paring and sequencing. The stack size may be read by the user but not written to.												
			CSEL1, 2		Communications setup bits. These bits reflect the state of the COMMS SELECT 1,2 pins and determine the operating mode of the communications ports. See Table 15 on page 31 .												
CRAT0, 1		Communications rate bits. These bits reflect the state of the COMMS RATE 0,1 pins and determine the bit rate of the Daisy Chain communications system. Table 17 on page 34 .															
Read/Write	3'b010	6'h19	Device Setup														
			13	12	11	10	9	8	7	6	5	4	3	2	1	0	
			WP5	WP4	WP3	WP2	WP1	WP0	BDDS	RESERVED	ISCN	SCAN	EOB	RESERVED	PIN37	PIN39	
			0	0	0	0	0	0	0	0	0	0	0	0	Pin	Pin	
			PIN37, PIN39		These bits indicate the signal level on pin 37 and pin 39 of the device.												
			EOB		End Of Balance. This bit is set by the device when balancing is complete. This function is used in the Timed Balance mode and Auto Balance mode . The <i>BEN</i> bit is cleared as a result of this bit being set. Initialized to 1.												
			SCAN		Scan Continuous mode . This bit is set in response to a Scan Continuous command and cleared by a Scan Inhibit command.												
			ISCN		Set wire scan current source/sink values. Set to 0 for 150µA. Set to 1 for 1mA.												
			BDDS		Balance condition during measurement. Controls the balance condition in Scan Continuous mode and Auto Balance mode . Set to 1 to have balancing functions turned off 10ms prior to and during cell voltage measurement. Set to 0 for normal operation (balancing functions not affected by measurement).												
WP5:0		Watchdog disable password. These bits must be set to 6'h3A (111010) before the watchdog can be disabled. Disable watchdog by writing 7'h00 to the watchdog bits.															
Read Only Value set in EEPROM	3'b010	6'h1A	Internal Temperature Limit Bit 0 is the LSB, Bit 13 is the MSB.														
			13	12	11	10	9	8	7	6	5	4	3	2	1	0	
			ITL 13	ITL 12	ITL 11	ITL 10	ITL 8	ITL 8	ITL 7	ITL 6	ITL 5	ITL 4	ITL 3	ITL 2	ITL 1	ITL 0	
			NV	NV	NV	NV	NV	NV	NV	NV	NV	NV	NV	NV	NV	NV	
ITL1 to ITL12		IC over-temperature limit value. Over-temperature limit is compared to the measured values for internal IC temperature to test for an over-temperature condition. The internal temperature limit value is stored in nonvolatile memory during test and loaded to these register bits at power-up. The register contents may be read by the user but not written to.															
Read Only	3'b010	6'h1B 6'h1C	Serial Number The 28b serial number programmed in nonvolatile memory during factory test is mirrored to these 2 x 14 bit registers. The serial number may be read at any time but may not be written.														

ACCESS	PAGE ADDR	REGISTER ADDRESS	DESCRIPTION														
Read Only Value set in EEPROM	3'b010	6'h1D	Trim Voltages														
			13	12	11	10	9	8	7	6	5	4	3	2	1	0	
			TV5	TV4	TV3	TV2	TV1	TV0	RESERVED								
			NV	NV	NV	NV	NV	NV	Ignore the Contents of these bits								
			TV5:0				Trim voltage (VNOM). The nominal cell voltage is programmed to nonvolatile memory during test and loaded to the Trim Voltage register at power up. The VNOM value is a 7-bit representation of the 0V to 5V cell voltage input range with 50 (7'h32) representing 5V (e.g., LSB = 0.1V). The parts are additionally marked with the trim voltage by the addition of a two digit code to the part number e.g., 3.3V is denoted by the code 33. (1 bit per 0.1V of trim voltage, so 0 to 50 decimal covers the full range.)										
Read Only	3'h010	6'h1F	Read all setup data from locations: 6'h10 - 6'h1D. See Figure 41D on page 40 .														

Cell Balance Registers

BASE ADDR (PAGE)	ACCESS	ADDRESS RANGE	DESCRIPTION
3'b010	Read/ Write	6'h20 - 6'h37	Cell balance registers. These registers are loaded with data related to change in SOC desired for each cell. This data is then used during Auto Balance mode . The data value is decremented with each successive ADC sample until a zero value is reached. The register space is arranged as 2 x 14-bit per cell for 24 x 14-bit total. The registers are cleared at device power up or by a Reset command. See "Auto Balance Mode" on page 27 .

ACCESS	PAGE ADDR	REGISTER ADDRESS	DESCRIPTION
Read/ Write	3'b010	6'h20	Cell 1 balance value bits 0 to 13.
		6'h21	Cell 1 balance value bits 14 to 27.
		~	
		6'h36	Cell 12 balance value bits 0 to 13.
		6'h37	Cell 12 balance value bits 14 to 27.

Reference Coefficient Registers

BASE ADDR (PAGE)	ACCESS	ADDRESS RANGE	DESCRIPTION
3'b010	Read Only	6'h38 - 6'h3A	Reference Coefficients. Bit 13 is the MSB, Bit 0 is the LSB

ACCESS	PAGE ADDR	REGISTER ADDRESS	DESCRIPTION													
Read Only Value set in EEPROM	3'b010	6'h38	Reference Coefficient C Reference calibration coefficient C LSB. Use with coefficients A and B and the measured reference value to obtain the compensated reference measurement. This result may be compared to limits given in the "Electrical Specifications" table beginning on page 7 to check that the reference is within limits. The register contents may be read by the user but not written to.													
			13	12	11	10	9	8	7	6	5	4	3	2	1	0
			RCC 13	RCC 12	RCC 11	RCC 10	RCC 9	RCC 8	RCC 7	RCC 6	RCC 5	RCC 4	RCC 3	RCC 2	RCC 1	RCC 0
			NV	NV	NV	NV	NV	NV	NV	NV	NV	NV	NV	NV	NV	NV

ACCESS	PAGE ADDR	REGISTER ADDRESS	DESCRIPTION													
Read Only	3'b010	6'h39	Reference Coefficient B Reference calibration coefficient B LSB. Use with coefficients A and C and the measured reference value to obtain the compensated reference measurement. This result may be compared to limits given in the “Electrical Specifications” table beginning on page 7 to check that the reference is within limits. The register contents may be read by the user but not written to.													
			13	12	11	10	9	8	7	6	5	4	3	2	1	0
			RCB 13	RCB 12	RCB 11	RCB 10	RCB 9	RCB 8	RCB 7	RCB 6	RCB 5	RCB 4	RCB 3	RCB 2	RCB 1	RCB 0
			NV	NV	NV	NV	NV	NV	NV	NV	NV	NV	NV	NV	NV	
Read Only	3'b010	6'h3A	Reference Coefficient A Reference calibration coefficient A LSB. Use with coefficients B and C and the measured reference value to obtain the compensated reference measurement. This result may be compared to limits given in the “Electrical Specifications” table beginning on page 7 to check that the reference is within limits. The register contents may be read by the user but not written to.													
			13	12	11	10	9	8	7	6	5	4	3	2	1	0
			RCA 8	RCA 7	RCA 6	RCA 5	RCA 4	RCA 3	RCA 2	RCA 1	RCA 0	RESERVED				
			NV	NV	NV	NV	NV	NV	NV	NV	NV	Ignore the content of these bits				

Cells In Balance Register

BASE ADDR (PAGE)	ACCESS	ADDRESS RANGE	DESCRIPTION
3'b010	Read Only	6'h3B	Cells In balance (valid for non-daisy chain configuration only).

ACCESS	PAGE ADDR	REGISTER ADDRESS	DESCRIPTION													
Read Only	3'b010	6'h3B	Cells Balance Enabled This register reports the current condition of the cell balance outputs. Bit 0 is the LSB, Bit 11 is the MSB.													
			13	12	11	10	9	8	7	6	5	4	3	2	1	0
			RESERVED		CBEN 12	CBEN 11	CBEN 10	CBEN 8	CBEN 8	CBEN 7	CBEN 6	CBEN 5	CBEN 4	CBEN 3	CBEN 2	CBEN 1
			0	0	0	0	0	0	0	0	0	0	0	0	0	
			BALI1 to BALI12		Indicates the current balancing status of cell 1 to cell 12 (respectively). “1” indicates balancing is enabled for this cell. “0” indicates that balancing is turned off.											

Device Commands

BASE ADDR (PAGE)	ACCESS	ADDRESS RANGE	DESCRIPTION
3'b011	Read Only	6'h01 - 6'h14	Device commands. Actions and communications administration. Not physical registers but memory mapped device commands. Commands from host and device responses are all configured as reads (BASE ADDR MSB = 0). Write operations breaks the communication rules and produce NAK from the target device.

PAGE ADDR	REGISTER ADDRESS	DESCRIPTION
3'b011	6'h01	Scan Voltages. Device responds by scanning V_{BAT} and all 12 cell voltages and storing the results in local memory.
	6'h02	Scan Temperatures. Device responds by scanning external temperature inputs, internal temperature, and the secondary voltage reference, and storing the results in local memory.
	6'h03	Scan Mixed. Device responds by scanning V_{BAT} , cell and EXT1 voltages and storing the results in local memory. The EXT1 measurement is performed in the middle of the cell voltage scans to minimize measurement latency between the cell voltages and the voltage on EXT1.
	6'h04	Scan Wires. Device responds by scanning for pin connection faults and stores the results in local memory.
	6'h05	Scan All. Device responds by performing the functions of the Scan Voltages, Scan Temperatures, and Scan Wires commands in sequence. Results are stored in local memory
	6'h06	Scan Continuous. Places the device in Scan Continuous mode by setting the Device Setup register SCAN bit.
	6'h07	Scan Inhibit. Stops Scan Continuous mode by clearing the Device Setup register SCAN bit.
	6'h08	Measure. Device responds by measuring a targeted single parameter (cell voltage/ V_{BAT} /external or internal temperatures or secondary voltage reference).
	6'h09	Identify. Special mode function used to determine device stack position and address. Devices record their own stack address and the total number of devices in the stack. See "Identify" on page 40 for details.
	6'h0A	Sleep. Places the part in Sleep mode (wakeup via daisy comms). See "Sleep Mode" on page 50 .
	6'h0B	NAK. Device response if communications is not recognized. The device responds NAK down the Daisy Chain to the host microcontroller. The host microcontroller typically retransmits on receiving a NAK.
	6'h0C	ACK. Used by host microcontroller to verify communications without changing anything. Devices respond with ACK.
	6'h0E	Comms Failure. Used in daisy chain implementations to communicate comms failure. If a communication is not acknowledged by a stack device, the last stack device that did receive the communication responds with Comms Failure. This is part of the communications integrity checking. Devices downstream of a communications fault are alerted to the fault condition by the watchdog function.
	6'h0F	Wakeup. Used in daisy chain implementations to wakeup a sleeping stack of devices. The Wakeup command is sent to the Bottom stack device (Master device) via SPI. The Master device then wakes up the rest of the stack by transmitting a low frequency clock. The Top stack device responds ACK once it is awake. See "Wakeup" on page 50 .
	6'h10	Balance Enable. Enables cell balancing by setting <i>BEN</i> . May be used to enable cell balancing on all devices simultaneously using the address All Stack Address 1111.
6'h11	Balance Inhibit. Disables cell balancing by clearing <i>BEN</i> . May be used to disable cell balancing on all devices simultaneously using the address All Stack Address 1111.	
6'h12	Reset. Resets all digital registers to its power-up state (i.e., reloads the factory programmed configuration data from non-volatile memory. Stops all scan and balancing activity. Daisy chain devices must be reset in sequence starting with the Top stack device and proceeding down the stack to the Bottom (Master) device. The Reset command must be followed by an Identify command (Daisy chain configuration) before volatile registers can be re-written.	
6'h13	Calculate register checksum. Calculates the checksum value for the current Page 2 register contents (registers with base address 0010). See "System Registers" on page 62 .	
6'h14	Check register checksum. Verifies the register contents are correct for the current checksum. An incorrect result sets the PAR bit in the Fault status register, which starts a standard fault response. See "System Registers" on page 62 .	

BASE ADDR (PAGE)	ACCESS	ADDRESS RANGE	DESCRIPTION
100	Read Only	6'h3F	Nonvolatile memory Multiple Input Shift Register (MISR) register. This checksum value for the nonvolatile memory contents. It is programmed during factory testing at Intersil.
101	Read Only	6'h00	MISR shadow register checksum value. This value is calculated when shadow registers are loaded from nonvolatile memory either after a power cycle or a reset.

Nonvolatile Memory (EEPROM) Checksum

A checksum is provided to verify the contents of EEPROM memory. Two registers are provided. One contains the correct checksum value, which is calculated during factory testing at Intersil. The other contains the checksum value that is calculated each time the non volatile memory is loaded to shadow registers,

either after a power cycle or after a device reset. Also refer to ["Memory Checksum" on page 45](#).

Applications Circuits Information

Typical Applications Circuits

Typical applications circuits are shown in [Figures 50 to 53](#). [Table 48 on page 77](#) contains recommended component values. All external (off-board) inputs to the ISL94212 are protected against battery voltage transients by RC filters, they also provide a current limit function during hot plug events. The ISL94212 is calibrated for use with 1k Ω series protection resistors at the cell inputs. V_{BAT} uses a lower value resistor to accommodate the V_{BAT} supply current of the ISL94212. A value of 27 Ω is used for this component. As much as possible, the time constant produced by the filtering applied to V_{BAT} should be matched to that applied to the cell 12 monitoring input. Component values given in [Table 48](#) produce the required matching characteristics.

[Figure 50 on page 73](#) shows the standard arrangement for connecting the ISL94212 to a stack of 12 cells. The cell input filter is designed to maximize EMI suppression. These components should be placed close to the connector with a well controlled ground to minimize noise for the measurement inputs. The balance circuits shown in [Figure 50](#) provide normal cell monitoring when the balance circuit is turned off, and a near zero cell voltage reading when the balance circuit is turned on. This is part of the diagnostic function of the ISL94212.

[Figure 51 on page 74](#) shows connections for the daisy chain system, setup pins, power supply and external voltage inputs for daisy chain devices other than the Master (stack bottom) device. The remaining circuits are discussed in more detail later in this datasheet.

[Figure 52 on page 75](#) shows the daisy chain system, setup pins, microcontroller interface, power supply and external voltage inputs for the daisy chain master device. [Figure 52](#) is also applicable to standalone (non-daisy chain) devices although in this case the daisy chain components connected to DHi2 and DLo2 would be omitted.

[Figure 53 on page 76](#) shows an alternate arrangement for the battery connections in which the cell input circuits are connected directly to the battery terminal and not via the balance resistor. In this condition the balance diagnostic function capability is removed.

Typical Application Circuits

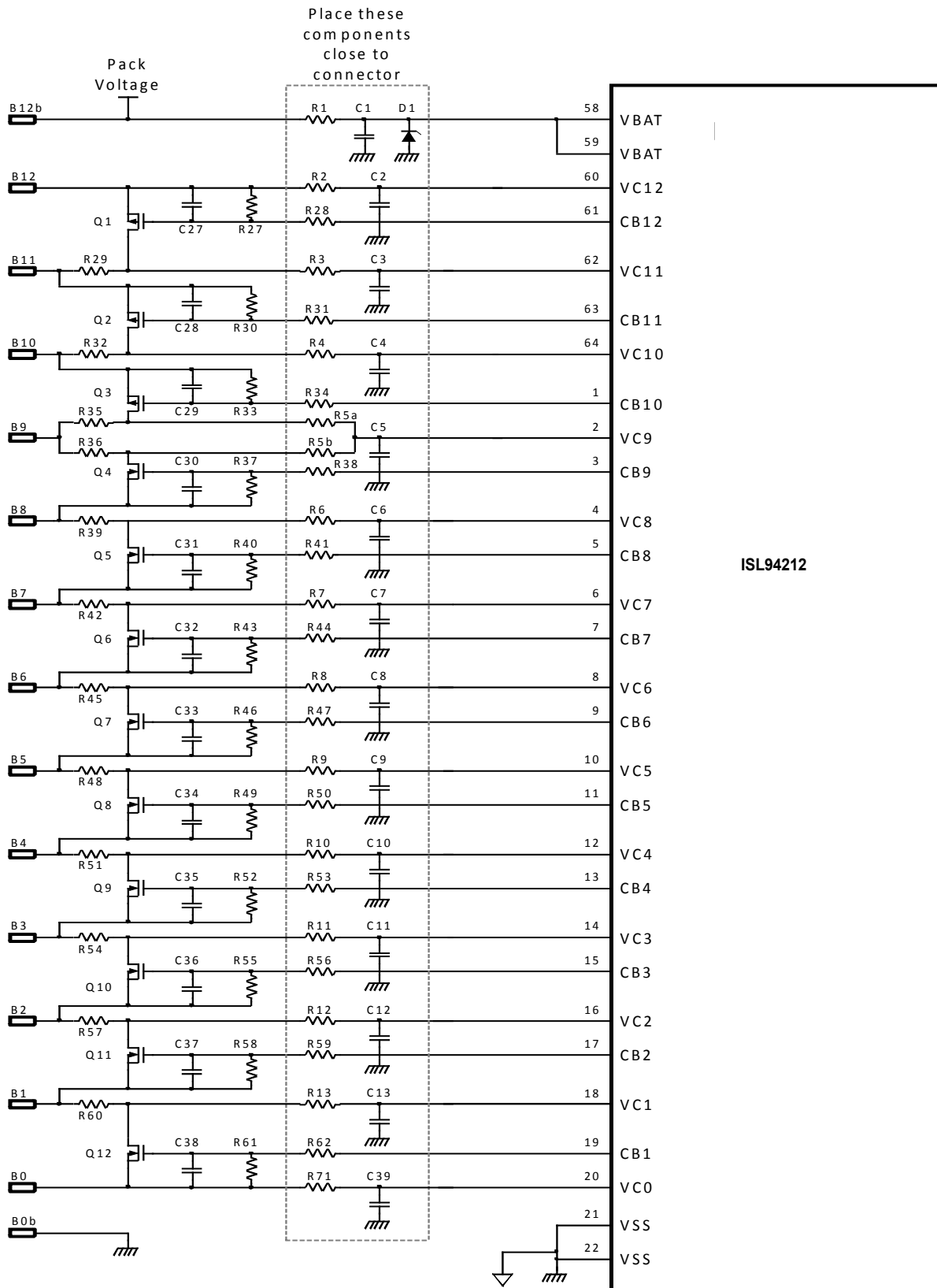

FIGURE 50. BATTERY CONNECTION CIRCUITS

Typical Application Circuits (Continued)

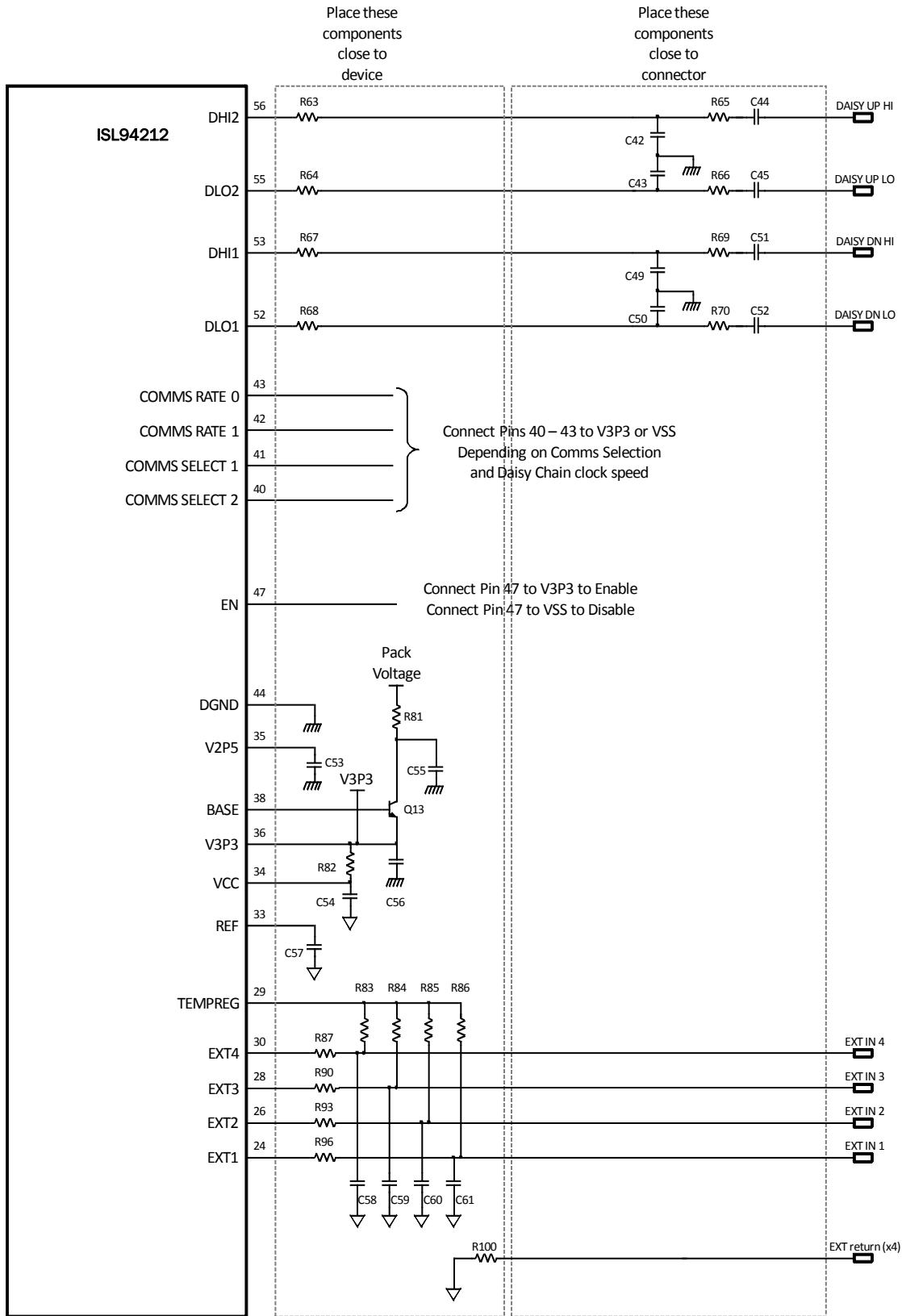

FIGURE 51. NON BATTERY CONNECTIONS, MIDDLE AND TOP DAISY CHAIN DEVICES

Typical Application Circuits (Continued)

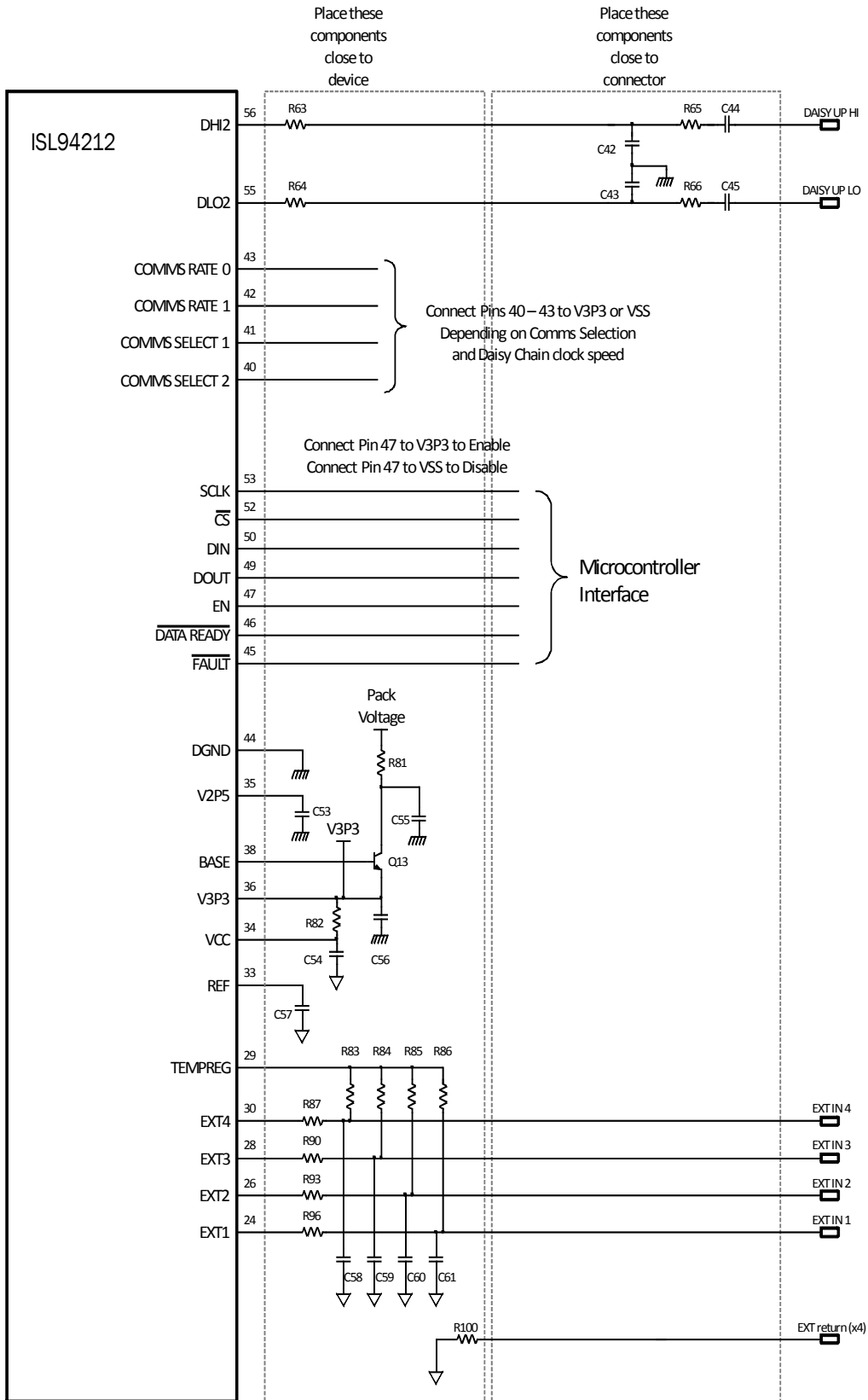

FIGURE 52. NON BATTERY CONNECTIONS, MASTER DAISY CHAIN DEVICE

Typical Application Circuits (Continued)

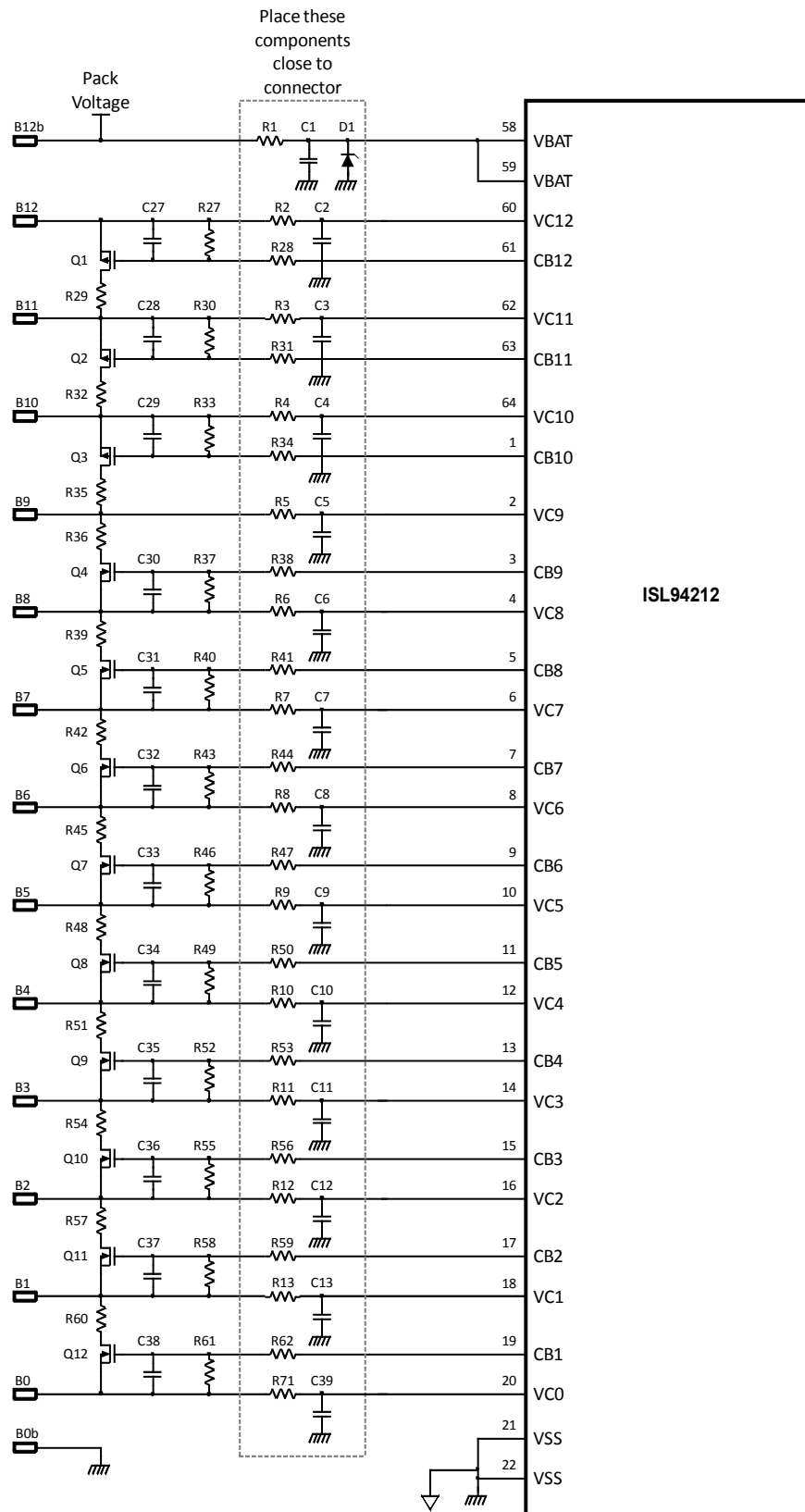

FIGURE 53. BATTERY CONNECTION CIRCUITS ALTERNATIVE CONFIGURATION

Notes on Board Layout

TABLE 48. RECOMMENDED COMPONENT VALUES FOR FIGURES (Figures 50 to 53)

RESISTORS		
VALUE		COMPONENTS
0		R101
27		R1
33		R82
1k		R2, R3, R4, R5, R6, R7, R8, R9, R10, R11, R12, R13, R71
100		R29, R32, R35, R36, R39, R42, R45, R48, R51, R54, R57, R60, R63, R64, R67, R68, R81
2k		R5a, R5b
470		R65, R66, R69, R70
10k		R28, R31, R34, R38, R41, R44, R47, R50, R53, R56, R59, R62, R83, R84, R85, R86, R87, R90, R93, R96, R100a, R100b, R100c, R100d
330k		R27, R30, R33, R37, R40, R43, R46, R49, R52, R55, R58, R61
CAPACITORS		
VALUE	VOLTAGE	COMPONENTS
200p	100	C42, C43, C49, C50
220p	500	C44, C45, C51, C52
10n	50	C27, C28, C29, C30, C31, C32, C33, C34, C35, C36, C37, C38, C58, C59, C60, C61
22n	100	C2, C3, C4, C5, C6, C7, C8, C9, C10, C11, C12, C13, C39
220n	100	C1
1 μ	10	C53, C54, C56
1 μ	100	C55
2.2 μ	10	C57
ZENER DIODES		
VALUE	EXAMPLE	COMPONENTS
60V	1N5371BRLG	D1

Referring to [Figure 50 on page 73](#) (battery connection circuits), the basic input filter structure comprises resistors R_2 to R_{13} , R_{71} and capacitors C_2 to C_{13} , C_{39} . These components provide protection against transients and EMI for the cell inputs. They carry the loop currents produced by EMI and should be placed as close to the connector as possible. The ground terminals of the capacitors must be connected directly to a solid ground plane. Do not use vias to connect these capacitors to the input signal path or to ground. Any vias should be placed in line to the signal inputs so that the inductance of these forms a low pass filter with the grounded capacitors.

Referring to [Figure 51 on page 74](#), the daisy chain components are shown to the top right of the drawing. These are split into two sections. Components to the right of this section should be placed close to the board connector with the ground terminals of capacitors connected directly to a solid ground plane. This is the same ground plane that serves the cell inputs. Components to the left of this section should be placed as closely to the device as possible.

The battery connector and daisy chain connectors should be placed closely to each other on the same edge of the board to minimize any loop current area.

Two grounds are identified on the circuit diagram. These are nominally referred to as noisy and quiet grounds. The noisy ground, denoted by an “earth” symbol carries the EMI loop currents and digital ground currents while the quiet ground is used to define the decoupling voltage for voltage reference and the analog power supply rail. The quiet and noisy grounds should be joined at the VSS pin. Keep the quiet ground area as small as possible.

The circuits shown to the bottom right of [Figure 51 on page 74](#) provide signal conditioning and EMI protection for the external temperature inputs. These inputs are designed to operate with external NTC thermistors. See [“External Inputs” on page 85](#) for more information about component selection.

Component Selection

Certain failures associated with external components can lead to unsafe conditions in electronic modules. A good example of this is a component that is connected between high energy signal sources failing short. Such a condition can easily lead to the component overheating and damaging the board and other components in its proximity.

One area to consider with the external circuits on the ISL94212 is the capacitors connected to the cell monitoring inputs. These capacitors are normally protected by the series protection resistors but could present a safety hazard in the event of a dual point fault where both the capacitor and associated series resistor fail short. Also, a short in one of these capacitors would dissipate the charge in the battery cell if left uncorrected for an extended period of time. It is recommended that capacitors C_1 to C_{13} be selected to be “fail safe” or “open mode” types. An alternative strategy would be to replace each of these capacitors with two devices in series, each with double the value of the single capacitor.

A dual point failure in the balancing resistor (R_{29} , R_{32} , R_{35} , etc.) of [Figure 50 on page 73](#) and associated balancing MOSFET (Q_1 to Q_{12}) could also give rise to a shorted cell condition. It is recommended that the balancing resistor be replaced by two resistors in series.

Operating the ISL94212 with Reduced Cell Counts

When using the ISL94212 with fewer than 12 cells it is important to ensure that each used cell has a normal input circuit connection to the top and bottom monitoring inputs for that cell. The simplest way to use the ISL94212 with any number of cells is to always use the full input circuit arrangement for all inputs, and short together the unused inputs at the battery terminal. In this way each cell input sees a normal source impedance independent of whether or not it is monitoring a cell.

The cell balancing components associated with unconnected cell inputs are not required and can be removed. Unused cell balance outputs should be tied to the adjacent cell voltage monitoring pin.

The input circuit component count can be reduced in cases where fewer than 10 cells are being monitored. It is important that cell inputs that are being used are not connected to other (unused) cell inputs as this would affect measurement accuracy. [Figure 54 on page 79](#), [Figure 55 on page 80](#), and [Figure 56 on page 81](#) show examples of systems with 10 cells, 8 cells, and 6 cells, respectively.

The component notations and values used in [Figures 55](#) and [56](#) are the same as those used in [Figures 50](#) to [53](#).

In [Figure 56](#) the resistor associated with the input filter on VC9 is noted as R_5 , rather than R_{5a} . This value change is needed to maintain the correct input network impedance in the absence of the cell 9 balance circuits.

Typical Application Circuits

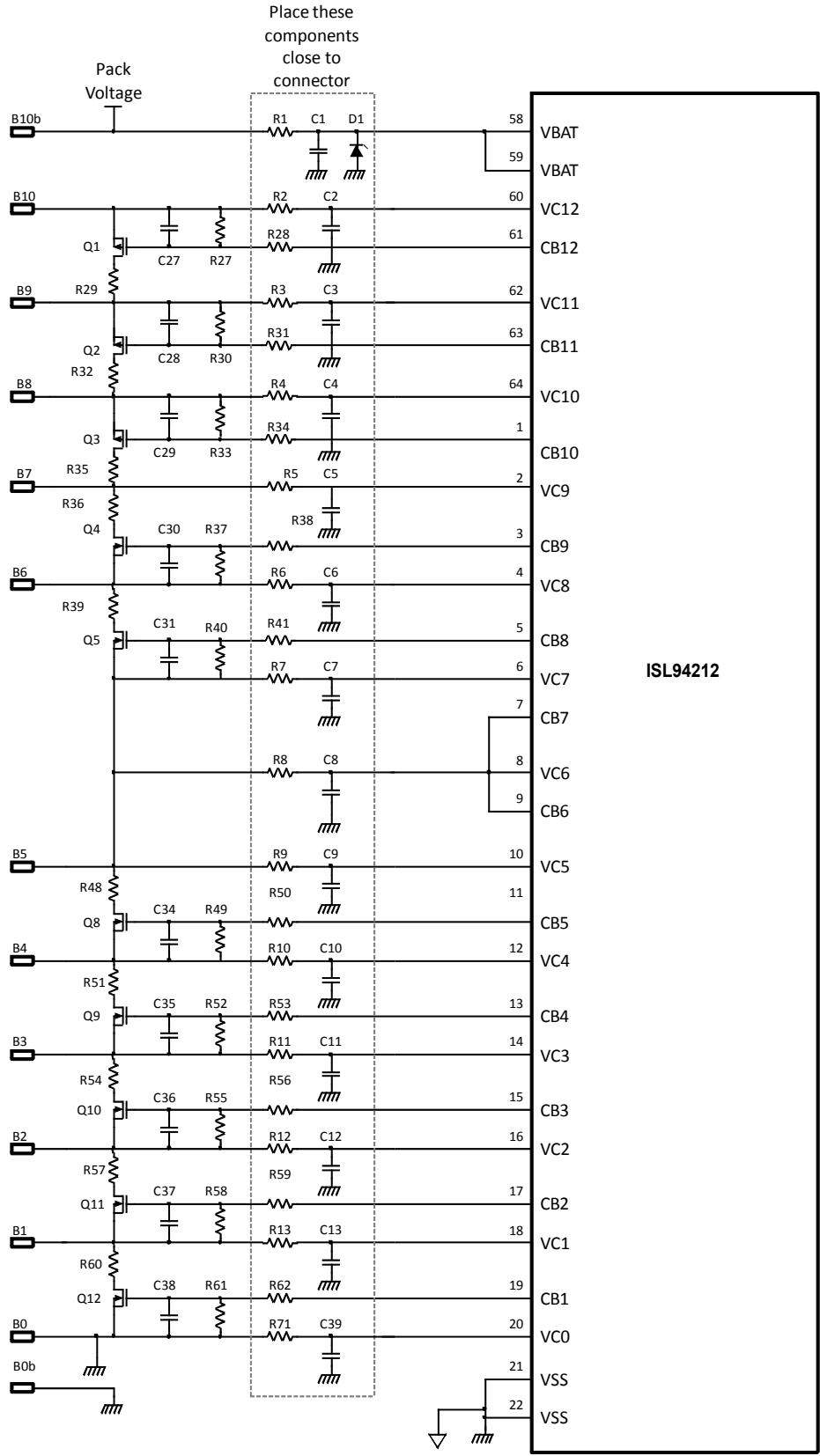
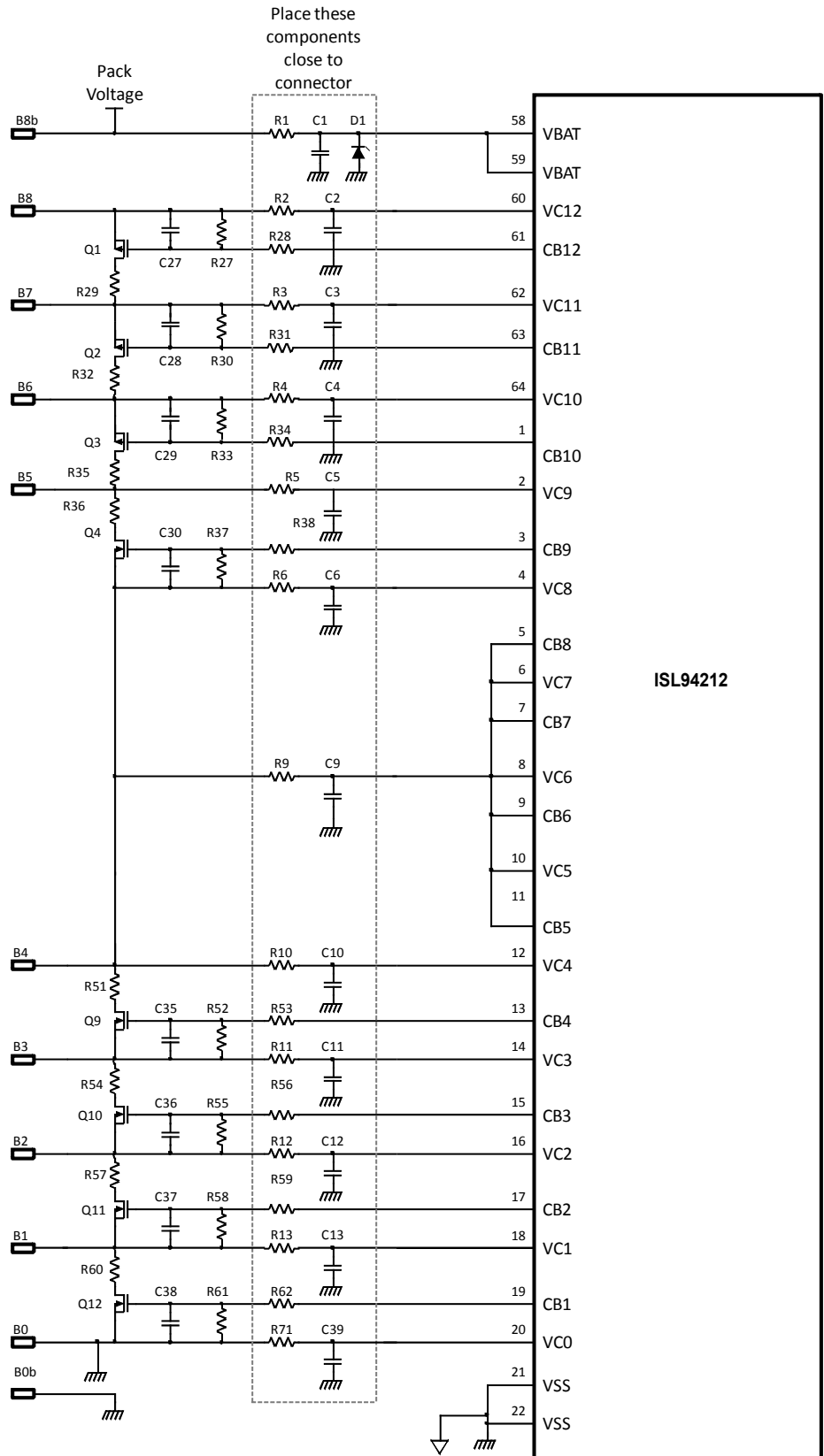

FIGURE 54. BATTERY CONNECTION CIRCUITS, SYSTEM WITH 10 CELLS

Typical Application Circuits (Continued)



ISL94212

FIGURE 55. BATTERY CONNECTION CIRCUITS, SYSTEM WITH 8 CELLS

Typical Application Circuits (Continued)

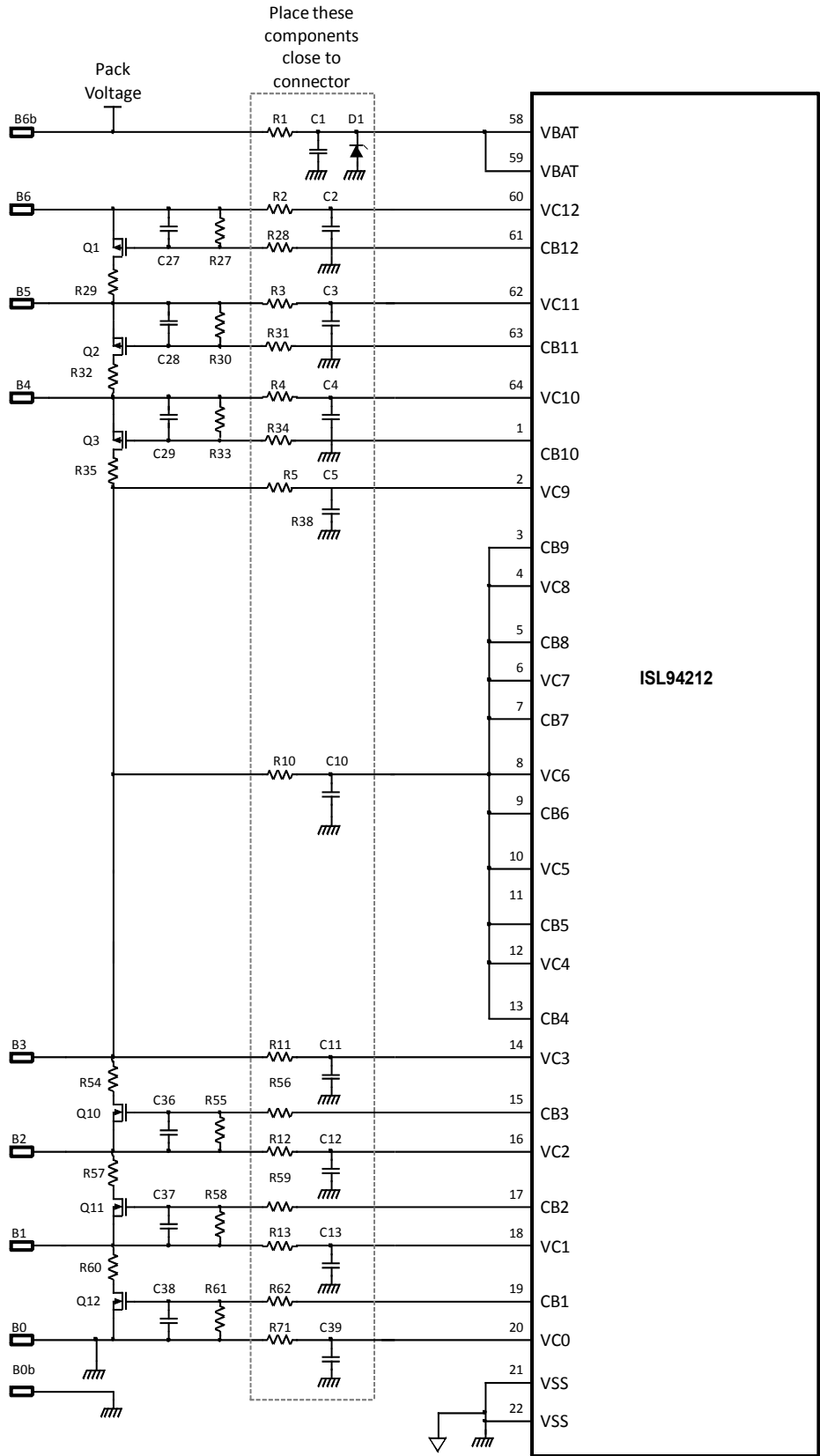
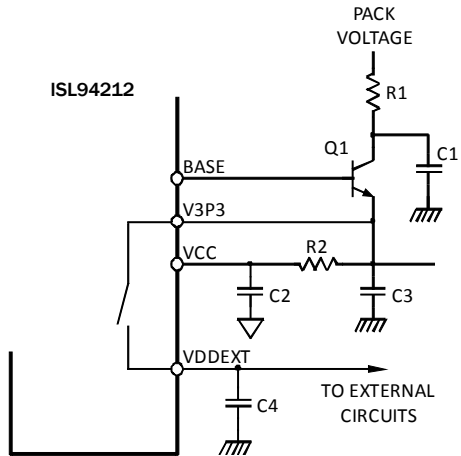

FIGURE 56. BATTERY CONNECTION CIRCUITS, SYSTEM WITH 6 CELLS



COMPONENT	VALUE
R ₁	Note 18
R ₂	33Ω
C ₁	Note 19
C ₂	1μF
C ₃	1μF
C ₄	1μF
Q ₁	Note 20

NOTES:

- R₁ should be sized to pass the maximum supply current at the minimum specified battery pack voltage.
- C₁ should be selected to produce a time constant with R₁ of a few milliseconds. C₁ and R₁ provide transient protection for the collector of Q₁. Component values and voltage ratings should be obtained through simulation or measurement of the worst case transient expected on V_{BAT}.
- Q₁ should be selected for power dissipation at the maximum specified battery voltage and load current. The load current includes the V3P3 and VCC currents for the ISL94212 and the maximum current drawn by external circuits supplied via VDDEXT. The voltage rating should be determined as described in [Note 19](#).

FIGURE 57. ISL94212 REGULATOR AND EXTERNAL CIRCUIT SUPPLY ARRANGEMENT

Power Supplies

The two VBAT pins, along with V3P3, VCC and VDDEXT are used to supply power to the ISL94212. Power for the high voltage circuits and **Sleep mode** internal regulators is provided via the VBAT pins. V3P3 is used to supply the logic circuits and VCC is similarly used to supply the low voltage analog circuits. The V3P3 and VCC pins must not be connected to external circuits other than those associated with the ISL94212 main voltage regulator. The VDDEXT pin is provided for use with external circuits.

The ISL94212 main low voltage regulator uses an external NPN pass transistor to supply 3.3V power for the V3P3 and VCC pins. This regulator is enabled whenever the ISL94212 is in **Normal mode** and may also be used to power external circuits via the VDDEXT pin. An internal switch connects the VDDEXT pin to the V3P3 pin. Both the main regulator and the switch are off when the part is placed in **Sleep mode** or **Shutdown mode** (EN pin LOW.) The pass transistor's base is connected to the ISL94212 BASE pin. A suitable configuration for the external components associated with the V3P3, VCC and VDDEXT pins is shown in [Figure 57](#). The external pass transistor is required. Do not allow this pin to float.

Voltage Reference Bypass Capacitor

A bypass capacitor is required between REF (pin 33) and the analog ground VSS. The total value of this capacitor should be in the range 2.0μF to 2.5μF. Use X7R type dielectric capacitors for this function. The ISL94212 continuously performs a power-good check on the REF pin voltage starting 20ms after a power-up, enable or wakeup condition. If the REF capacitor is too large, then the reference voltage may not reach its target voltage range

before the Power-good check starts and result in a REF Fault. If the capacitor is too small, then it may lead to inaccurate voltage readings.

Cell Balancing Circuits

The ISL94212 uses external MOSFETs for the cell balancing function. The gate drive for these is derived from on-chip current sources on the ISL94212, which are 25μA nominally. The current sources are turned on and off as needed to control the external MOSFET devices. The current sources are turned off when the device is in **Shutdown mode** or in **Sleep mode**. The ISL94212 uses a mix of N-channel and P-channel MOSFETs for the external balancing function. The top three cell locations, cell 10, 11, 12 are configured to use P-channel MOSFETs while the remaining cell locations, cell 1 through 9, use N-channel MOSFETs.

[Figure 58](#) shows the circuit detail for one cell balancing system with typical component values. An N-channel MOSFET (cell locations 1 through 9) is shown. The gate of the external FET is normally protected against excessive voltages during cell voltage transients by the action of the parasitic C_{gs} and C_{gd} capacitances. These momentarily turn on the FET in the event of a large transient, thus limiting the V_{gs} values to reasonable levels. A 10nF capacitor is included between the MOSFET gate and source terminals to protect against EMI effects. This capacitor provides a low impedance path to ground at high frequencies and prevents the MOSFET turning on in response to high frequency interference.

The external component values should be chosen to prevent the 9V clamp at the output from the ISL94212 from activating.

Cell Voltage Measurements During Balancing

The standard cell balancing circuit ([Figure 50 on page 73](#) and [Figure 58 on page 84](#)) is configured so that the cell measurement is taken from the drain connection of the balancing MOSFET. When balancing is enabled for a cell, the resulting cell measurement is then the voltage across the balancing MOSFET (VGS voltage). This system provides the diagnostic for the cell balancing function. The input voltage of the cell adjacent to the MOSFET drain connection is also affected by this mechanism: the input voltage for this cell increases by the same amount that the voltage of the balance cell decreases.

For example, if cell 2 and cell 3 are both at 3.6V and balancing is enabled for cell 2, then the voltage across the balancing MOSFET may be only 50mV. In this case, cell 2 would read 50mV and cell 3 would read 7.15V. The cell 3 value in this case is outside the measurement range of the cell input. Cell 3 would then read full scale voltage, which is 4.9994V. This full scale voltage reading will occur if the sum of the voltages on the two adjacent cells is greater than the total of 5V plus the “balancing on” voltage of the balanced cell. [Table 49](#) shows the cell affected when each cell is balanced.

TABLE 49. CELL READINGS DURING BALANCING

CELL BALANCED	CELL WITH LOW READING	CELL WITH HIGH READING
1	1	2
2	2	3
3	3	4
4	4	5
5	5	6
6	6	7
7	7	8
8	8	9
9	9*	10*
10	10*	9*
11	11	10
12	12	11

NOTE: *cells 9 and 10 produce a different result from the other cells. Cell 9 uses an N-channel MOSFET while cell 10 uses a P-channel MOSFET. The circuit arrangement used with these devices produces approximately half the normal cell voltage when balancing is enabled. The adjacent cell then sees an increase of half the voltage of the balanced cell.

The voltage measurement behavior outlined above is modified by impedances in the cell connector and any associated wiring. The balance current passes through the connections at the top and bottom of the balanced cell. This effect further reduces the measured voltage on the balanced cell and also increase the voltage measured on cells above and below the balanced cell. For example, if cell 4 is balanced with 100mA and the total impedance of the connector and wiring for each cell connection is 0.1 Ω , then cell 4 would read low by an additional 20mV (10mV due to each connection) while cells 3 and 5 would both read high by 10mV.

Balancing with Scan Continuous Mode Enabled

Cell balancing may be active while the ISL94212 is operating in **Scan Continuous mode**. In **Scan Continuous mode** the ISL94212 scans cell voltages, temperatures and open wire conditions at a rate determined by the Scan Interval bits in the Fault Setup register. (See [Table 2 on page 23](#)). The behavior of the balancing functions while operating in **Scan Continuous mode** is controlled by the BDDS bit in the Device Setup register. If BDDS is set, then cell balancing is inhibited during cell voltage measurements and for 10ms before the cell voltage scan to allow the balance devices to turn off. Balancing is reenabled at the end of the scan and then balancing continues.

Daisy Chain Communications System

The ISL94212 daisy chain communications system uses differential, AC-coupled signaling. The external circuit arrangement is symmetrical to provide a bidirectional communications function. The performance of the system under transient voltage and EMI conditions is enhanced by the use of a capacitive load. A schematic of the daisy chain circuit is shown in [Figure 59](#).

The basic circuit elements are the series resistor and capacitor elements R_1 and C_1 , which provide the transient current limit and AC coupling functions, and the line termination components C_2 , which provide the capacitive load. Capacitors C_1 and C_2 should be located as closely as possible to the board connector.

The AC coupling capacitors C_1 need to be rated for the maximum voltage, including transients, that will be applied to the interface. Specific component values are needed for correct operation with each daisy chain data rate and are given in [Table 50](#).

The daisy chain operates with standard unshielded twisted pair wiring. The component values given in [Table 50](#) will accommodate cable capacitance values from 0pF to 50pF when operating at the 500kHz data rate. Higher cable capacitance values may be accommodated by either reducing the value of C_2 or operating at lower data rates.

The values of components in [Figure 59](#) are given in [Table 50](#) for various daisy chain operating data rates.

The circuit and component values in [Figure 59](#) and [Table 50](#) will accommodate cables with differential capacitance values in the ranges given. This allows a range of cable lengths to be accommodated through careful selection of cable properties.

The circuit in [Figure 59](#) provides full isolation when used with off board wiring. The daisy chain external circuit can be simplified in cases where the daisy chain system is contained within a single board. [Figure 60 on page 85](#) and [Table 51 on page 85](#) show the circuit arrangement and component values for single board use. In this case the AC coupling capacitors C_1 need only be rated for the maximum transient voltage expected from device to device.

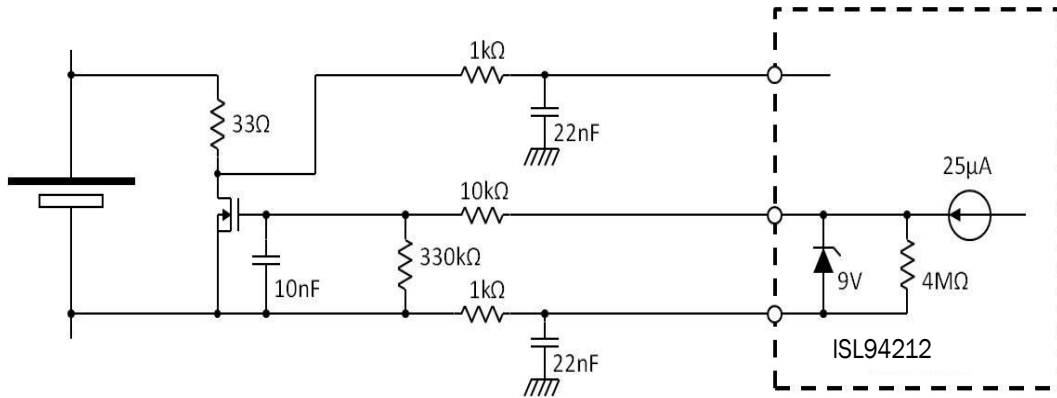

FIGURE 58. BALANCE CIRCUIT ARRANGEMENT

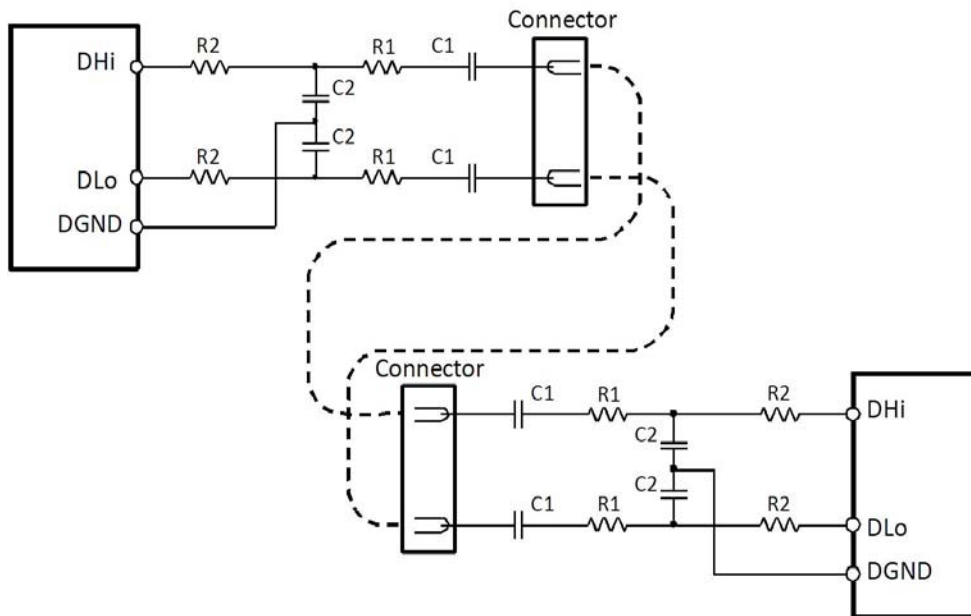

FIGURE 59. ISL94212 DAISY CHAIN CIRCUIT IMPLEMENTATION

TABLE 50. COMPONENT VALUES IN FIGURE 59 FOR VARIOUS DAISY CHAIN DATA RATES

COMPONENT	DAISY CHAIN CLOCK RATES				Comments
	500kHz	250kHz	125kHz	62.5kHz	
C ₁ (4 pcs)	220pF	470pF	1nF	2.2nF	NPO dielectric type capacitors are recommended. Please consult Intersil if Y type or "open mode" devices are required for your application.
C ₂ (4 pcs)	200pF (Note)	440pF	940pF	2nF	Use same dielectric type as C ₁
R ₁ (4 pcs)	470Ω	470Ω	470Ω	470Ω	
R ₂ (4 pcs)	100Ω	100Ω	100Ω	100Ω	
Cable Capacitance Range	0 to 50pF	0 to 100pF	0 to 200pF	0 to 400pF	

NOTE: Can be accommodated using two 100pF capacitors in parallel.

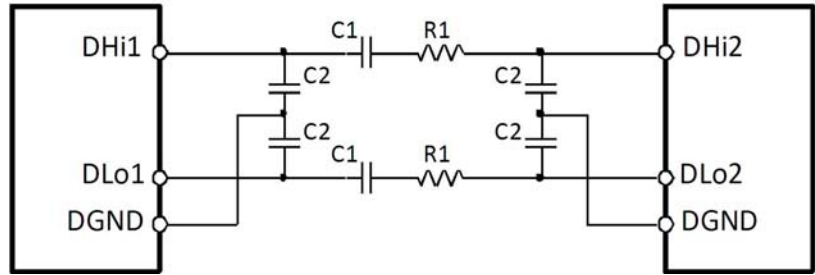

FIGURE 60. ISL94212 DAISY CHAIN - BOARD LEVEL IMPLEMENTATION CIRCUIT

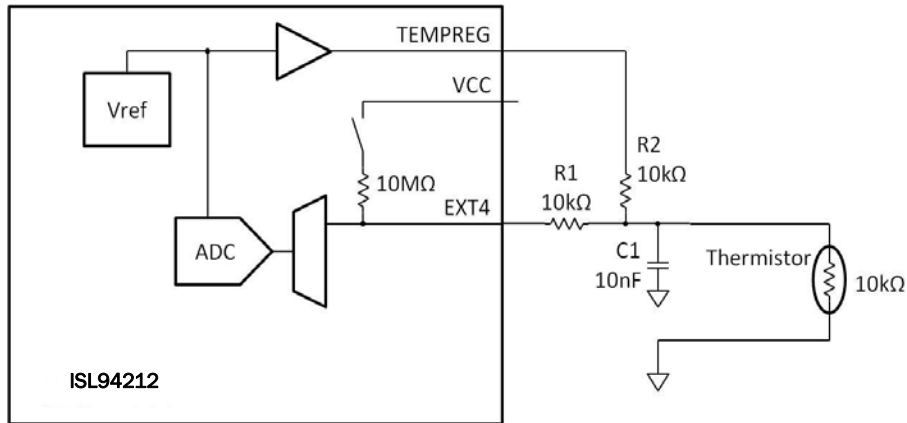

FIGURE 61. CONNECTION OF NTC THERMISTOR TO INPUT EXT4

TABLE 51. DAISY CHAIN COMPONENT VALUES FOR BOARD LEVEL IMPLEMENTATION

COMPONENT	TOLERANCE	DAISY CHAIN DATA RATE			
		500kHz	250kHz	125kHz	62.5kHz
C ₁ (2 pcs)	5%	100pF	220pF	470pF	1nF
C ₂ (4 pcs)	5%	220pF	470pF	1nF	2.2nF
R ₁ (4 pcs)		1kΩ	1kΩ	1kΩ	1kΩ

External Inputs

The ISL94212 provides 4 external inputs for use either as general purpose analog inputs or for NTC type thermistors. Each of the external inputs has an internal pull-up resistor, which is connected by a switch to the VCC pin whenever the TEMPREG output is active. This arrangement results in an open input being pulled up to the VCC voltage.

Inputs above 15/16 of full scale are registered as open inputs and cause the relevant bit in the Over-temperature Fault register, along with the OT bit in the Fault Status register to be set, on condition of the respective temperature test enable bit in the Fault Setup register. The user must then read the register value associated with the faulty input to determine if the fault was due to an open input (value above 15/16 full scale) or an over-temperature condition (value below the external temp limit setting).

The arrangement of the external inputs is shown in [Figure 61](#) using the Ext4 input as an example. It is important that the components are connected in the sequence shown in [Figure 61](#), e.g., C₁ must be connected such the trace from this capacitor's positive terminal connects to R₂ before connecting to R₁. This guarantees the correct operation of the various fault detection functions.

The function of each of the components in [Figure 61](#) is listed in [Table 52](#) together with the diagnostic result of an open or short fault in each component

TABLE 52. COMPONENT FUNCTIONS AND DIAGNOSTIC RESULTS FOR CIRCUIT OF FIGURE 61

COMPONENT	FUNCTION	DIAGNOSTIC RESULT
R ₁	Protection from wiring shorts to external HV connections.	Open: Open wire detection Short: No diagnostic result
R ₂	Measurement high-side resistor	Open: Low input level (over-temperature indication) Short: High input level (open wire indication).
Thermistor		Open: High input level (open wire indication). Short: Low input level (over-temperature indication)
C ₁	Noise Filter. Connects to measurement ground VSS.	Open: no diagnostic result. Short: Low input level (over-temperature indication)

Board Level Calibration

For best accuracy, the ISL94212 may be recalibrated after soldering to a board using a simple resistor trim. The adjustment method involves obtaining the average cell reading error for the cell inputs at a single temperature and cell voltage value and applying a select-on-test resistor to zero the average cell reading error.

The adjustment system uses a resistor placed either between VDDEXT and V_{REF} or V_{REF} and VSS as shown in Figure 62. The value of resistor R₁ or R₂ is then selected based on the average error measured on all cells at 3.3V per cell and room temperature e.g., with 3.3V on each cell input scan the voltage values using the ISL94212 and record the average reading error (ISL94212 reading – cell voltage value). Table 53 shows the value of R₁ and R₂ required for various measured errors.

To use Table 53, find the measured error value closest to the result obtained with measurements using the ISL94212 and select the corresponding resistor value. Alternatively, if finer adjustment resolution is required then this may be obtained by interpolation using Table 53.

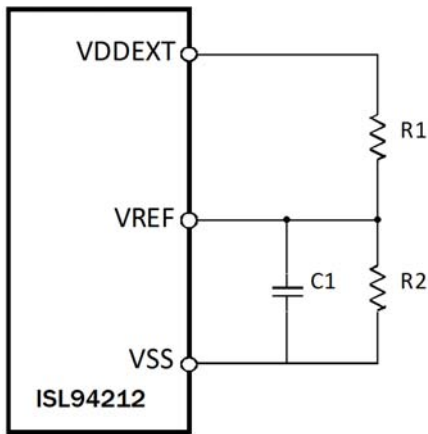

FIGURE 62. CELL READING ACCURACY ADJUSTMENT SYSTEM

TABLE 53. COMPONENT VALUES FOR ACCURACY CALIBRATION ADJUSTMENT OF FIGURE 62

MEASURED ERROR AT VC = 3.3V (mV) V ₇₈₆₀₀ - V _{CELL} (mV)	R ₁ (kΩ)	R ₂ (kΩ)
4	205	DNP
3	274	DNP
2	412	DNP
1	825	DNP
0	DNP	DNP
-1	DNP	2550
-2	DNP	1270
-3	DNP	866
-4	DNP	649

DNP = Do Not populate

Worked Examples

The following worked examples are provided to assist with the setup and calculations associated with various functions.

Voltage Reference Check Calculation

TABLE 54. EXAMPLE REGISTER DATA

R/W	PAGE	ADDRESS	PARAMETER	VALUE (HEX)	DECIMAL
0	001	010000	IC Temperature	14'h2425	9253
0	001	010101	Reference Voltage	14'h20A7	8359
0	010	111000	Coefficient C	14'h00A4	164
0	010	111001	Coefficient B	14'h3FCD	-51
0	010	111010	Coefficient A	9'h006	6

Coefficients A, B and C are two's compliment numbers. B and C have a range +8191 to -8192. A has a range +255 to -256.

Coefficient B above is a negative number (Hex value > 1FFF). The value for B is 14'h3FCD - 14h3FFF- 1 or (16333₁₀ -16383₁₀ - 1) = -51.

Coefficient A occupies the upper 9 bits of register 6'b111010 (6'h3A). One way to extract the coefficient data from this register is to divide the complete register value by 32 and rounding the result down to the nearest integer. With 9'h006 in the upper 9 bits, and assuming the lower 5 bits are 0, the complete register value will be 14'h0C0 = 192 decimal. Divide this by 32 to obtain 6.

Coefficients A, B and C are used with the IC temperature reading to calibrate the Reference Voltage reading. The calibration is applied by subtracting an adjustment of the form (see Equation 5) from the Reference Voltage reading.

$$\text{Adjustment} = \frac{A}{256 \times 8192} \times dT^2 + \frac{B}{8192} \times dT + C \quad (\text{EQ. 5})$$

An example calculation using the data from Table 54 is given in Equation 6.

$$dT = \frac{9253 - 9180}{2} = 36.5 \quad (\text{EQ. 6})$$

Where 9180 is the Internal Temperature Monitor reading at +25° C (see the "Electrical Specifications" table, T_{INT25} on page 10).

$$\text{Adjustment} = \frac{6}{256 \times 8192} \times (36.5)^2 - \frac{51}{8192} \times 36.5 + 164 = 163.8 \quad (\text{EQ. 7})$$

$$\text{Corrected } V_{REF} = 8359 - 163.8 = 8195.2 \quad (\text{EQ. 8})$$

$$V_{REF} \text{ value} = \frac{8195.2}{16384} \times 5 = 2.5010 \quad (\text{EQ. 9})$$

Cell Balancing – Manual Mode

Refer to "Manual Balance Mode" on page 26.

EXAMPLE: ACTIVATE BALANCING ON CELLS 1, 5, 7 AND 11

Step 1. Write Balance Setup register: Set Manual Balance mode, Balance Status pointer, and turn off balance.

BMD = 01 (Manual Balance mode)
BWT = XXX
BSP = 0000 (Balance status pointer location 0)
BEN = 0 (Balancing disabled)

Note: Green text indicates a register change.

BALANCE SETUP REGISTER

R̄/W	PAGE	ADDRESS	DATA
1	010	010011	XX XX00 000X XX01

X = don't care

Step 2. Write Balance Status register: Set bits 0, 4, 6 and 10

BAL12:1 = 0100 0101 0001

BALANCE STATUS REGISTER

R̄/W	PAGE	ADDRESS	DATA
1	010	010100	XX 0100 0101 0001

Step 3. Enable balancing using Balance Enable command

BALANCE ENABLE COMMAND

R̄/W	PAGE	ADDRESS	DATA
0	011	010000	00 0000

Or enable balancing by setting BEN directly in the Balance Setup register:

BEN = 1

BALANCE SETUP REGISTER

R̄/W	PAGE	ADDRESS	DATA
1	010	010011	XX XX1X XXXX XXXX

The balance FETs attached to cells 1, 5, 7 and 11 turn on.

Turn balancing off by resetting BEN or by sending the Balance Inhibit command (Page 3, address 6'h11).

Cell Balancing – Timed Mode

Refer to "Timed Balance Mode" on page 27.

EXAMPLE: ACTIVATE BALANCING ON CELLS 2 AND 8 FOR 1 MINUTE.

Step 1. Write Balance Setup register: Set Timed Balance mode, Balance Status pointer, and turn off balance.

BMD = 10 (Timed Balance mode)
BWT = XXX
BSP = 0000 (Balance status pointer location 0)
BEN = 0 (BALANCING disabled)

BALANCE SETUP REGISTER

R̄/W	PAGE	ADDRESS	DATA
1	010	010011	XX XX00 000X XX10

X = don't care

Step 2. Write Balance Status register: Set bits 1 and 7

BAL12:1 = 0000 1000 0010

BALANCE STATUS REGISTER

R̄/W	PAGE	ADDRESS	DATA
1	010	010100	XX 0000 1000 0010

Step 3. Write balance timeout setting to the Watchdog/Balance Time register (page 2, address 6'h15, bits [13:7])

BTM6:1 = 0000011 (1 minute)

WATCHDOG/BALANCE TIME REGISTER

R/W	PAGE	ADDRESS	DATA
1	010	010101	00 0001 1XXX XXXX

X = don't care – the lower bits are the watchdog timeout value and should be set to a time longer than the balance time. A value of 111 1111 is suggested.

Step 4. Enable balancing using Balance Enable command

BALANCE ENABLE COMMAND

R/W	PAGE	ADDRESS	DATA
0	011	010000	00 0000

Or enable balancing by setting BEN directly in the Balance Setup register:

BEN = 1

BALANCE SETUP REGISTER

R/W	PAGE	ADDRESS	DATA
1	010	010011	XX XX1X XXXX XXXX

The balance FETs attached to cells 2 and 8 turn on. The FETs turn off after 1 minute. Balancing may be stopped by resetting BEN or by sending the Balance Inhibit command.

Cell Balancing – Auto Mode

Refer to [“Auto Balance Mode” on page 27.](#)

BALANCE VALUE CALCULATION EXAMPLE

This example is based on a cell State of Charge (SOC) of 9360 coulombs, a target SOC of 8890 coulombs, a balancing leg impedance of 31Ω (30Ω resistor plus 1Ω FET on resistance) and a sampling time interval of 5 minutes (300 seconds).

The Balance Value is calculated using [Equation 10.](#)

$$B = \frac{8191}{5} \times (9360 - 8890) \times \frac{31}{300} = 79562 = 28'h00136CA \quad (\text{EQ. 10})$$

The value 8191/5 is the scaling factor of the cell voltage measurement.

The value of 28'h00136CA is loaded to the required Cell Balance Register and the value 7'b0001111 (5 minutes) is loaded to the Balance Time bits in the Watchdog/Balance time register.

In this example, the total coulomb difference to be balanced is: 470 coulomb (9360 - 8890). At 3.3V/31Ω*300s = 31.9 coulomb per cycle, it takes about 15 cycles for the balancing to terminate.

AUTO BALANCE MODE CELL BALANCING EXAMPLE

The following describes a simple setup to demonstrate the **Auto Balance mode** cell balancing function of the ISL94212. Note that this balancing setup is not related to the balance value calculation in [Equation 10.](#)

Auto balance cells using the following criteria:

- Balance time = 20s
- Balance wait time (dead time between balancing cycles) = 8s
- Balancing disabled during cell measurements.
- Balance Values: See [Table 55](#)

TABLE 55. CELL BALANCE VALUES (HEX) FOR EACH CELL

CELL 1	CELL 2	CELL 3	CELL 4	CELL 5	CELL 6	CELL 7	CELL 8	CELL 9	CELL 10	CELL 11	CELL 12
28'h 406A	28'h 3E4D	28'h 0	28'h 292F	28'h 3E00	28'h 0	28'h 2903	28'h 3D06	28'h 0	28'h 151E	28'h 502	28'h 6D6

- Balance Status Register: Set up balance:
 - Cells 1, 4, 7 and 10 on 1st cycle.
 - Cells 3, 6, 9 and 12 on 2nd cycle.
 - Cells 2, 5, 8 and 11 on 3rd cycle
 (See [Table 56](#))

TABLE 56. BALANCE STATUS SETUP

BPS [3:0]	CELL											
	1	2	3	4	5	6	7	8	9	10	11	12
0000	Reserved for Manual Balance mode and Timed Balance mode											
0001	1	0	0	1	0	0	1	0	0	1	0	0
0010	0	0	1	0	0	1	0	0	1	0	0	1
0011	0	1	0	0	1	0	0	1	0	0	1	0

Step 1. Write Balance Value registers

BALANCE VALUE REGISTERS

R/W	PAGE	ADDRESS	DATA (HEX)	CELL
1	010	100000	14'h006A	1
1	010	100001	14'h0001	
1	010	100010	14'h3E4D	2
1	010	100011	14'h0000	
1	010	100100	14'h0000	3
1	010	100101	14'h0000	
1	010	100110	14'h292F	4
1	010	100111	14'h0000	
1	010	101000	14'h3E00	5
1	010	101001	14'h0000	
1	010	101010	14'h0000	6
1	010	101011	14'h0000	
1	010	101100	14'h2903	7
1	010	101101	14'h0000	
1	010	101110	14'h3D06	8
1	010	101111	14'h0000	
1	010	110000	14'h0000	9
1	010	110001	14'h0000	
1	010	110010	14'h151E	10
1	010	110011	14'h0000	
1	010	110100	14'h0502	11
1	010	110101	14'h0000	
1	010	110110	14'h06D6	12
1	010	110111	14'h0000	

BALANCE VALUE REGISTERS (CELL1) - VALUE 28'h406A

6'20	B0107	B0106	B0105	B0104	B0103	B0102	B0101	B0100
	0	1	1	0	1	0	1	0
			B0113	B0112	B0111	B0110	B0109	B0108
		0	0	0	0	0	0	0
6'21	B0121	B0120	B0119	B0118	B0117	B0116	B0115	B0114
	0	0	0	0	0	0	0	1
			B0127	B0126	B0125	B0124	B0123	B0122
		0	0	0	0	0	0	0

Step 2. Write BDDS bit in Device Setup register (turn balancing functions off during measurement)

BDDS = 1

DEVICE SETUP REGISTER

R/W	PAGE	ADDRESS	DATA
1	010	011001	XX XXXX 1XXX XXXX

X = don't care

Step 3. Write balance timeout setting to the Watchdog/Balance Time register: Balance timeout code = 0000001 (20 seconds)

BTM6:0 = 000 0001

BALANCE TIMEOUT REGISTER

R/W	PAGE	ADDRESS	DATA
1	010	010101	00 0000 1XXX XXXX

X = don't care - the lower bits are the watchdog timeout value and should be set to a time longer than the balance time. A value 111 1111 is suggested.

Step 4. Set up Balance Status register (from Table 56 on page 88)

Step 4A. Write Balance Setup register: Set Auto Balance mode, set 8 second Balance wait time, and set balance off:

BMD = 11 (Auto Balance mode)

BWT = 100 (8 seconds)

BEN = 0 (Balancing disabled)

BALANCE SETUP REGISTER

R/W	PAGE	ADDRESS	DATA
1	010	010011	XX XX0X XXX1 0011

X = don't care

Step 4B. Write Balance Setup register: Set Balance Status Pointer = 1

BSP = 0001 (Balance status pointer = 1)

BALANCE SETUP REGISTER

R/W	PAGE	ADDRESS	DATA
1	010	010011	XX XXX0 001X XXXX

X = don't care

Step 4C. Write Balance Status register: Set bits 1, 4, 7 and 10

BAL12:1 = 0010 0100 1001

BALANCE STATUS REGISTER

R/W	PAGE	ADDRESS	DATA
1	010	010100	XX 0010 0100 1001

Step 4D. Write Balance Setup register: Set Balance Status Pointer = 2

BSP = 0010 (Balance status pointer = 2)

BALANCE SETUP REGISTER

R/W	PAGE	ADDRESS	DATA
1	010	010011	XX XXX0 010X XXXX

X = don't care

Step 4E. Write Balance Status register: Set bits 3, 6, 9 and 12

BAL12:1 = 1001 0010 0100

BALANCE STATUS REGISTER

R̄/W	PAGE	ADDRESS	DATA
1	010	010100	XX 1001 0010 0100

Step 4F. Write Balance Setup register: Set Balance Status Pointer = 3

BSP = 0011 (Balance status pointer = 3)

BALANCE SETUP REGISTER

R̄/W	PAGE	ADDRESS	DATA
1	010	010011	XX XXX0 011X XXXX

X = don't care

Step 4G. Write Balance Status register: Set bits 2, 5, 8 and 11

BAL12:1 = 0100 1001 0010

BALANCE STATUS REGISTER

R̄/W	PAGE	ADDRESS	DATA
1	010	010100	XX 0100 1001 0010

Step 4H. Write Balance Setup register: Set Balance Status Pointer = 4

BSP = 0100 (Balance status pointer = 4)

BALANCE SETUP REGISTER

R̄/W	PAGE	ADDRESS	DATA
1	010	010011	XX XXX0 100X XXXX

X = don't care

Step 4I. Write Balance Status register: Set bits to all zero to set the end point for the instances.

BAL12:1 = 0000 0000 0000

BALANCE STATUS REGISTER

R̄/W	PAGE	ADDRESS	DATA
1	010	010100	XX 0000 0000 0000

Step 5. Enable balancing using the Balance Enable command

BALANCE ENABLE COMMAND

R̄/W	PAGE	ADDRESS	DATA
0	011	010000	00 0000

Or enable balancing by setting BEN directly in the Balance Setup register:

BEN = 1

BALANCE SETUP REGISTER

R̄/W	PAGE	ADDRESS	DATA
1	010	010011	XX XX1X XXXX XXXX

The balance FETs cycle through each instance of the Balance Status register in a loop, interposing the balance wait time between each instance. The measured voltage of each cell being balanced is subtracted from the balance value for that cell at the end of each balance status instance. The process continues until the Balance Value register for each cell contains zero.

Register Map

R̄/W + PAGE		ADDRESS	REGISTER NAME	BIT 7	BIT 6	BIT 5	BIT 4	BIT 3	BIT 2	BIT 1	BIT 0
READ	WRITE			BIT 13	BIT 12	BIT 11	BIT 10	BIT 9	BIT 8		
0001		000000	V _{BAT} Voltage	VB7	VB6	VB5	VB4	VB3	VB2	VB1	VB0
						VB13	VB12	VB11	VB10	VB9	VB8
0001		000001	Cell 1 Voltage	C1V7	C1V6	C1V5	C1V4	C1V3	C1V2	C1V1	C1V0
						C1V13	C1V12	C1V11	C1V10	C1V9	C1V8
0001		000010	Cell 2 Voltage	C2V7	C2V6	C2V5	C2V4	C2V3	C2V2	C2V1	C2V0
						C2V13	C2V12	C2V11	C2V10	C2V9	C2V8
0001		000011	Cell 3 Voltage	C3V7	C3V6	C3V5	C3V4	C3V3	C3V2	C3V1	C3V0
						C3V13	C3V12	C3V11	C3V10	C3V9	C3V8
0001		000100	Cell 4 Voltage	C4V7	C4V6	C4V5	C4V4	C4V3	C4V2	C4V1	C4V0
						C4V13	C4V12	C4V11	C4V10	C4V9	C4V8
0001		000101	Cell 5 Voltage	C5V7	C5V6	C5V5	C5V4	C5V3	C5V2	C5V1	C5V0
						C5V13	C5V12	C5V11	C5V10	C5V9	C5V8

Register Map (Continued)

R/W + PAGE		ADDRESS	REGISTER NAME	BIT 7	BIT 6	BIT 5	BIT 4	BIT 3	BIT 2	BIT 1	BIT 0
READ	WRITE			BIT 13	BIT 12	BIT 11	BIT 10	BIT 9	BIT 8		
0001		000110	Cell 6 Voltage	C6V7	C6V6	C6V5	C6V4	C6V3	C6V2	C6V1	C6V0
						C6V13	C6V12	C6V11	C6V10	C6V9	C6V8
0001		000111	Cell 7 Voltage	C7V7	C7V6	C7V5	C7V4	C7V3	C7V2	C7V1	C7V0
						C7V13	C7V12	C7V11	C7V10	C7V9	C7V8
0001		001000	Cell 8 Voltage	C8V7	C8V6	C8V5	C8V4	C8V3	C8V2	C8V1	C8V0
						C8V13	C8V12	C8V11	C8V10	C8V9	C8V8
0001		001001	Cell 9 Voltage	C9V7	C9V6	C9V5	C9V4	C9V3	C9V2	C9V1	C9V0
						C9V13	C9V12	C9V11	C9V10	C9V9	C9V8
0001		001010	Cell 10 Voltage	C10V7	C10V6	C10V5	C10V4	C10V3	C10V2	C10V1	C10V0
						C10V13	C10V12	C10V11	C10V10	C10V9	C10V8
0001		001011	Cell 11 Voltage	C11V7	C11V6	C11V5	C11V4	C11V3	C11V2	C11V1	C11V0
						C11V13	C11V12	C11V11	C11V10	C11V9	C11V8
0001		001100	Cell 12 Voltage	C12V7	C12V6	C12V5	C12V4	C12V3	C12V2	C12V1	C12V0
						C12V13	C12V12	C12V11	C12V10	C12V9	C12V8
0001		001111	All Cell Voltage Data	Daisy chain configuration only. This command returns all Page 1 data from address 6'h00 through 6'h0C in a single data stream. See "Communication Sequences" on page 36 and "Address All" on page 42. See example in Figure 41D on page 40 .							
0001		010000	IC Temperature	ICT7	ICT6	ICT5	ICT4	ICT3	ICT2	ICT1	ICT0
						ICT13	ICT12	ICT11	ICT10	ICT9	ICT8
0001		010001	External Temperature Input 1 Voltage (ExT1 pin)	ET1V7	ET1V6	ET1V5	ET1V4	ET1V3	ET1V2	ET1V1	ET1V0
						ET1V13	ET1V12	ET1V11	ET1V10	ET1V9	ET1V8
0001		010010	External Temperature Input 2 Voltage (ExT2 pin)	ET2V7	ET2V6	ET2V5	ET2V4	ET2V3	ET2V2	ET2V1	ET2V0
						ET2V13	ET2V12	ET2V11	ET2V10	ET2V9	ET2V8
0001		010011	External Temperature Input 3 Voltage (ExT3 pin)	ET3V7	ET3V6	ET3V5	ET3V4	ET3V3	ET3V2	ET3V1	ET3V0
						ET3V13	ET3V12	ET3V11	ET3V10	ET3V9	ET3V8
0001		010100	External Temperature Input 4 Voltage (ExT4 pin)	ET4V7	ET4V6	ET4V5	ET4V4	ET4V3	ET4V2	ET4V1	ET4V0
						ET4V13	ET4V12	ET4V11	ET4V10	ET4V9	ET4V8
0001		010101	Secondary Reference Voltage	RV7	RV6	RV5	RV4	RV3	RV2	RV1	RV0
						RV13	RV12	RV11	RV10	RV9	RV8
0001		010110	Scan Count					SCN3	SCN2	SCN1	SCN0
0001		011111	All Temperature Data	Daisy chain configuration only. This command returns all Page 1 data from address 6'h10 through 6'h16 in a single data stream. See "Communication Sequences" on page 36 and "Address All" on page 42 .							
0010	1010	000000	Overvoltage Fault	OF8	OF7	OF6	OF5	OF4	OF3	OF2	OF1
								OF12	OF11	OF10	OF9
0010	1010	000001	Undervoltage Fault	UF8	UF7	UF6	UF5	UF4	UF3	UF2	UF1
								UF12	UF11	UF10	UF9

Register Map (Continued)

R/W + PAGE		ADDRESS	REGISTER NAME	BIT 7	BIT 6	BIT 5	BIT 4	BIT 3	BIT 2	BIT 1	BIT 0
READ	WRITE			BIT 13	BIT 12	BIT 11	BIT 10	BIT 9	BIT 8		
0010	1010	000010	Open Wire Fault	OC7	OC6	OC5	OC4	OC3	OC2	OC1	OC0
							OC12	OC11	OC10	OC9	OC8
0010	1010	000011	Fault Setup	TOT2	TOT1	TOT0	WSCN	SCN3	SCN2	SCN1	SCN0
							TTST4	TTST3	TTST2	TTST1	TTST0
0010	1010	000100	Fault Status	OW	UV	OV	OT	WDGF	OSC	0	0
						MUX	REG	REF	PAR	OVSS	OV _{BAT}
0010	1010	000101	Cell Setup	C8	C7	C6	C5	C4	C3	C2	C1
						FFSN	FFSP	C12	C11	C10	C9
0010	1010	000110	Over-temperature Fault				TFLT4	TFLT3	TFLT2	TFLT1	TFLT0
0010		001111	All Fault Data	Daisy Chain configuration only. This command returns all Page 2 data from address 6'h00 through 6'h06 in a single data stream. See "Communication Sequences" on page 36 and "Address All" on page 42 .							
0010	1010	010000	Overvoltage Limit	OV7	OV6	OV5	OV4	OV3	OV2	OV1	OV0
						OV13	OV12	OV11	OV10	OV9	OV8
0010	1010	010001	Undervoltage Limit	UV7	UV6	UV5	UV4	UV3	UV2	UV1	UV0
						UV13	UV12	UV11	UV10	UV9	UV8
0010	1010	010010	External Temp Limit	ETL7	ETL6	ETL5	ETL4	ETL3	ETL2	ETL1	ETL0
						ETL13	ETL12	ETL11	ETL10	ETL9	ETL8
0010	1010	010011	Balance Setup	BSP2	BSP1	BSP0	BWT2	BWT1	BWT0	BMD1	BMD0
										BEN	BSP3
0010	1010	010100	Balance Status (Cells to Balance)	BAL8	BAL7	BAL6	BAL5	BAL4	BAL3	BAL2	BAL1
								BAL12	BAL11	BAL10	BAL9
0010	1010	010101	Watchdog/Balance Time	BTM0	WDG6	WDG5	WDG4	WDG3	WDG2	WDG1	WDG0
						BTM6	BTM5	BTM4	BTM3	BTM2	BTM1
0010	1010	010110	User Register	UR7	UR6	UR5	UR4	UR3	UR2	UR1	UR0
						UR13	UR12	UR11	UR10	UR9	UR8
0010	1010	010111	User Register	UR21	UR20	UR19	UR18	UR17	UR16	UR15	UR14
						UR27	UR26	UR25	UR24	UR23	UR22
0010		011000	Comms Setup	SIZE3	SIZE2	SIZE1	SIZE0	ADDR3	ADDR2	ADDR1	ADDR0
								CRAT1	CRAT0	CSEL2	CSEL1
0010	1010	011001	Device Setup	BDDS	0	ISCN	SCAN	EOB	0	Pin 37	Pin 39
						WP5	WP4	WP3	WP2	WP1	WP0
0010		011010	Internal Temp Limit	ITL7	ITL6	ITL5	ITL4	ITL3	ITL2	ITL1	ITL0
						ITL13	ITL12	ITL11	ITL10	ITL9	ITL8
0010		011011	Serial Number 0	SN7	SN6	SN5	SN4	SN3	SN2	SN1	SN0
						SN13	SN12	SN11	SN10	SN9	SN8
0010		011100	Serial Number 1	SN21	SN20	SN19	SN18	SN17	SN16	SN15	SN14
						SN27	SN26	SN25	SN24	SN23	SN22

Register Map (Continued)

R/W + PAGE		ADDRESS	REGISTER NAME	BIT 7	BIT 6	BIT 5	BIT 4	BIT 3	BIT 2	BIT 1	BIT 0
READ	WRITE			BIT 13	BIT 12	BIT 11	BIT 10	BIT 9	BIT 8		
0010		011101	Trim Voltage	RESERVED							
						TV5	TV4	TV3	TV2	TV1	TV0
0010		011111	All Setup Data	Daisy Chain configuration only. This command returns all Page 2 data from address 6'h10 through 6'h1D in a single data stream. See "Communication Sequences" on page 36 and "Address All" on page 42 .							
0010	1010	100000	Cell 1 Balance Value 0	B0107	B0106	B0105	B0104	B0103	B0102	B0101	B0100
						B0113	B0112	B1011	B0110	B0109	B0108
0010	1010	100001	Cell 1 Balance Value 1	B0121	B0120	B0119	B0118	B0117	B0116	B0115	B0114
						B0127	B0126	B0125	B0124	B0123	B0122
0010	1010	100010	Cell 2 Balance Value 0	B0207	B0206	B0205	B0204	B0203	B0202	B0201	B0200
						B0213	B0212	B1011	B0210	B0209	B0208
0010	1010	100011	Cell 2 Balance Value 1	B0221	B0220	B0219	B0218	B0217	B0216	B0215	B0214
						B0227	B0226	B0225	B0224	B0223	B0222
		~	~	~							
0010	1010	110111	Cell 12 Balance Value 1	B1221	B1220	B1219	B1218	B1217	B1216	B1215	B1214
						B1227	B1226	B1225	B1224	B1223	B1222
0010		111000	Reference Coefficient C	RCC7	RCC6	RCC5	RCC4	RCC3	RCC2	RCC1	RCC0
						RCC13	RCC12	RCC11	RCC10	RCC9	RCC8
0010		111001	Reference Coefficient B	RCB7	RCB6	RCB5	RCB4	RCB3	RCB2	RCB1	RCB0
						RCB13	RCB12	RCB11	RCB10	RCB9	RCB8
0010		111010	Reference Coefficient A	RCA2	RCA1	RCA0	RESERVED				
						RCA8	RCA7	RCA6	RCA5	RCA4	RCA3
0010		111011	Cell Balance Enabled	CBEN8	CBEN7	CBEN6	CBEN5	CBEN4	CBEN3	BAL2	CBEN1
								CBEN12	CBEN11	CBEN10	CBEN9
0011		000001	Scan Voltages								
0011		000010	Scan Temperatures								
0011		000011	Scan Mixed								
0011		000100	Scan Wires								
0011		000101	Scan All								
0011		000110	Scan Continuous								
0011		000111	Scan Inhibit								
0011		001000	Measure								
0011		001001	Identify								
0011		001010	Sleep								
0011		001011	NAK								
0011		001100	ACK								
0011		001110	Comms Failure								
0011		001111	Wakeup								
0011		010000	Balance Enable								

Register Map (Continued)

R/W + PAGE		ADDRESS	REGISTER NAME	BIT 7	BIT 6	BIT 5	BIT 4	BIT 3	BIT 2	BIT 1	BIT 0
READ	WRITE			BIT 13	BIT 12	BIT 11	BIT 10	BIT 9	BIT 8		
0011		010001	Balance Inhibit								
0011		010010	Reset								
0011		010011	Calc Register Checksum								
0011		010100	Check Register Checksum								
0100		111111	EEPROM MISR Data Register	14-bit MISR EEPROM checksum value. Programmed during test.							
0101		000000	MISR Calculated Checksum	14-bit shadow register MISR checksum value. Calculated when shadow registers are loaded from nonvolatile memory							

© Copyright Intersil Americas LLC 2012-2015. All Rights Reserved.
All trademarks and registered trademarks are the property of their respective owners.

For additional products, see www.intersil.com/en/products.html

Intersil products are manufactured, assembled and tested utilizing ISO9001 quality systems as noted in the quality certifications found at www.intersil.com/en/support/qualandreliability.html

Intersil products are sold by description only. Intersil may modify the circuit design and/or specifications of products at any time without notice, provided that such modification does not, in Intersil's sole judgment, affect the form, fit or function of the product. Accordingly, the reader is cautioned to verify that datasheets are current before placing orders. Information furnished by Intersil is believed to be accurate and reliable. However, no responsibility is assumed by Intersil or its subsidiaries for its use; nor for any infringements of patents or other rights of third parties which may result from its use. No license is granted by implication or otherwise under any patent or patent rights of Intersil or its subsidiaries.

For information regarding Intersil Corporation and its products, see www.intersil.com

Revision History

The revision history provided is for informational purposes only and is believed to be accurate, but not warranted. Please go to web to make sure you have the latest Rev.

DATE	REVISION	CHANGE
April 23, 2015	FN7938.1	<p>Changed ground references in Figure 1 on page 1.</p> <p>Abs Max "Absolute Maximum Ratings" on page 7 changed the text in the ESD Ratings from Capacitive Discharge to Charge Device Model</p> <p>"Recommended Operating Conditions" on page 7 moved ExT1, ExT2, ExT3, ExT4, which had voltage range 0V to 3.6V to separate line with voltage range 0V to 2.5V.</p> <p>Added to "BASE" in "Pin Descriptions" on page 5, "Do not let this pin float."</p> <p>Table 3 on page 24, Changed "Cell 0 Voltage" to "VBAT Voltage".</p> <p>Section , "CRC Calculation," on page 36: Added example software CRC calculation code (Figure 39 on page 37.)</p> <p>Section , "Reset," on page 42 - Added note: "A Reset command should be issued following a "hard reset" in which the EN pin is toggled."</p> <p>Changed "Fault Signal Filtering" on page 46 to add the comment in 2nd paragraph, "When a fault is detected, the [TOT2:0] bits should be rewritten."</p> <p>Table 30 on page 47, changed in comments for "Read checksum value calculated by ISL94212" from: ..."cycling the EN pin or the host issuing a Reset command." to: ..."cycling the EN pin followed by a host initiated Reset command, or simply the host issuing a Reset command."</p> <p>Changed Section, "System Registers," on page 62. Changed in 4th paragraph 1st sentence "when the EN pin is low" to "when the EN pin is toggled and the device receives a Reset Command".</p> <p>Section, "Register Descriptions," on page 62: Changed "Cell 0 Voltage" to "VBAT Voltage" and added voltage calculation equations.</p> <p>System Register description "TOTO, 1, 2" on page 64 added the comment, "This register must be re-written following an error detection resulting from totalizer overflow."</p> <p>Added to last sentence 2nd paragraph in Section, "Power Supplies," on page 82, "The external pass transistor is required. Do not allow this pin to float."</p> <p>Changed all pin name references to all caps.</p> <p>Updated Definitions for Shutdown Mode in "Power Modes" on page 21 and "Reset" on page 42.</p> <p>Table 50 on page 84, Updated recommendation for C1</p> <p>Replaced "Measurement and Communication Timing" Section (pages 51 to 58 of previous document) with new sections "Communication and Measurement Diagrams" on page 50 and "Communication and Measurement Timing Tables" on page 56 with new figures and tables to offer more clarity and flexibility in communication and measurement timing calculations.</p>
December 14, 2012	FN7938.0	Initial Release.

About Intersil

Intersil Corporation is a leading provider of innovative power management and precision analog solutions. The company's products address some of the largest markets within the industrial and infrastructure, mobile computing and high-end consumer markets.

For the most updated datasheet, application notes, related documentation and related parts, please see the respective product information page found at www.intersil.com.

You may report errors or suggestions for improving this datasheet by visiting www.intersil.com/ask.

Reliability reports are also available from our website at www.intersil.com/support

Package Outline Drawing

Q64.10x10D

64 LEAD THIN PLASTIC QUAD FLATPACK PACKAGE

Rev 2, 9/12

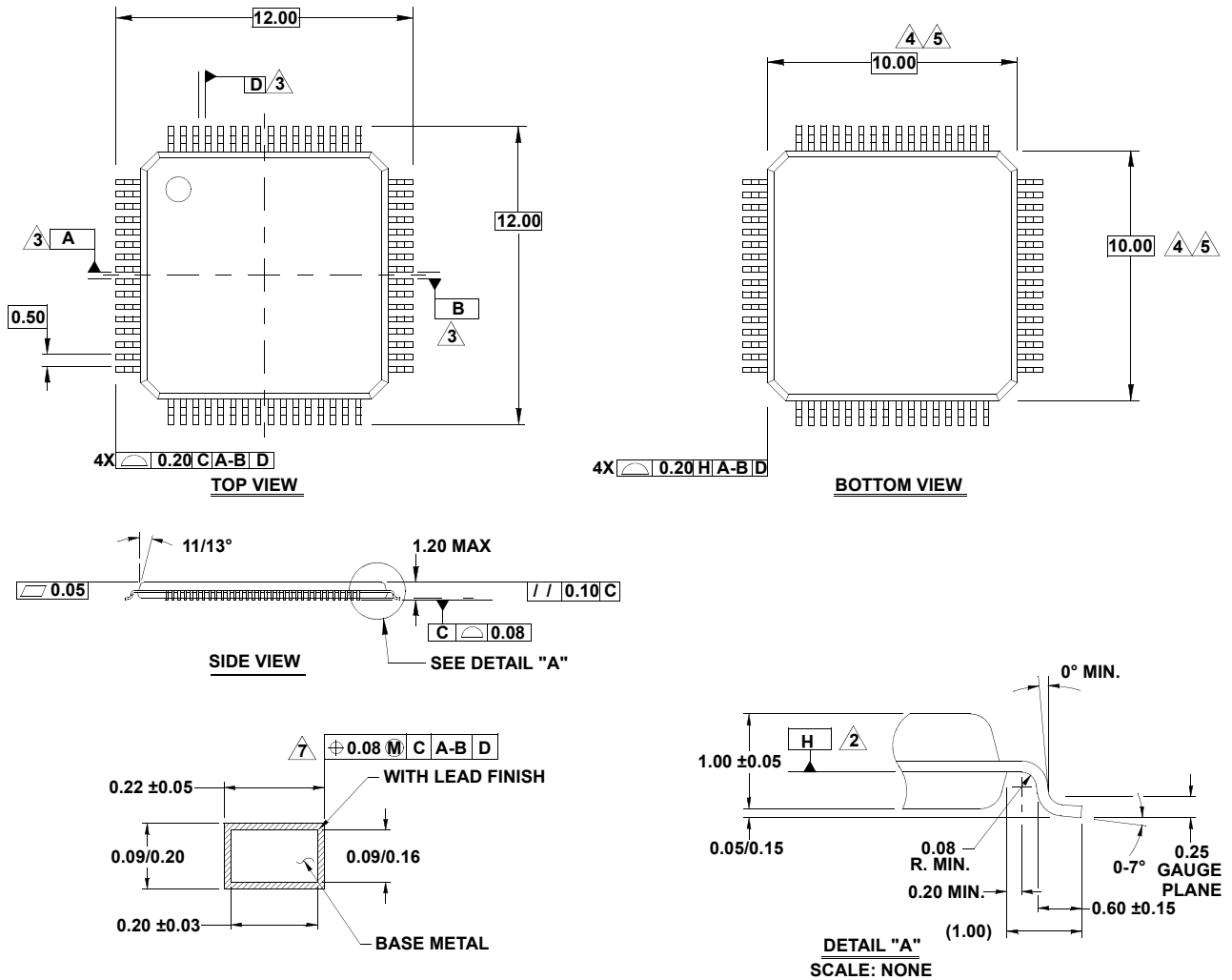

NOTES:

- All dimensioning and tolerancing conform to ANSI Y14.5-1982.
- Datum plane H located at mold parting line and coincident with lead, where lead exits plastic body at bottom of parting line.
- Datums A-B and D to be determined at centerline between leads where leads exit plastic body at datum plane H.
- Dimensions do not include mold protrusion. Allowable mold protrusion is 0.254mm.
- These dimensions to be determined at datum plane H.
- Package top dimensions are smaller than bottom dimensions and top of package will not overhang bottom of package.
- Does not include dambar protrusion. Allowable dambar protrusion shall be 0.08mm total at maximum material condition. Dambar cannot be located on the lower radius or the foot.
- Controlling dimension: millimeter.
- This outline conforms to JEDEC publication 95 registration MS-026, variation ACD.
- Dimensions in () are for reference only.

Looking for pricing, stock, or lifecycle information?

Click below to explore more details on WIN SOURCE:

 [View ISL94212INZ-T on WIN SOURCE](#)

 [Intersil Information](#)

Optimize Your Supply Chain with WIN SOURCE Solutions

-  Global Sourcing Solution
-  Obsolete Management
-  Cost Control Management
-  Shortage Management
-  Alternative Solution
-  Excess Inventory Management