



**THE DATASHEET OF
ISL9203ACRZ**



ISL9203A

Li-Ion/Li Polymer Battery Charger

The [ISL9203A](#) is an integrated single-cell Li-ion or Li-polymer battery charger capable of operating with an input voltage as low as 2.4V. This charger is designed to work with various types of AC adapters.

The ISL9203A operates as a linear charger when the AC adapter is a voltage source. The battery is charged in a Constant Current/Constant Voltage (CC/CV) profile. The charge current is programmable with an external resistor up to 1.5A. The ISL9203A can also work with a current-limited adapter to minimize the thermal dissipation, in which case the ISL9203A combines the benefits of both a linear charger and a pulse charger.

The ISL9203A features charge current thermal foldback to ensure safe operation when the Printed Circuit Board (PCB) is space limited for thermal dissipation. Additional features include preconditioning of an over-discharged battery and thermally enhanced DFN package.

Related Literature

For a full list of related documents, visit our website:

- [ISL9203A](#) device page

Features

- Complete charger for single-cell Li-ion batteries
- Very low thermal dissipation
- Integrated pass element and current sensor
- No external blocking diode required
- 1% voltage accuracy
- Programmable current limit up to 1.5A
- Charge current thermal foldback
- Accepts multiple types of adapters
- Operation down to $V_{IN} = 2.65V$ after startup
- Ambient temperature range: $-20^{\circ}C$ to $+70^{\circ}C$
- Thermally-enhanced DFN packages
- Pb-free (RoHS compliant)

Applications

- Handheld devices, including medical handhelds
- PDAs, cell phones, and smartphones
- Portable instruments and MP3 players
- Self-charging battery packs
- Stand-alone chargers
- USB bus-powered chargers

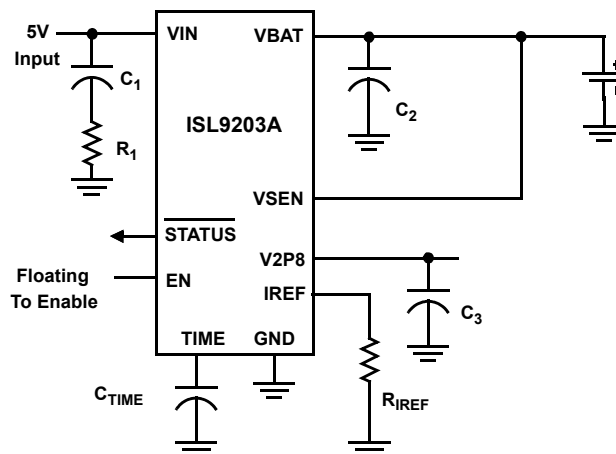
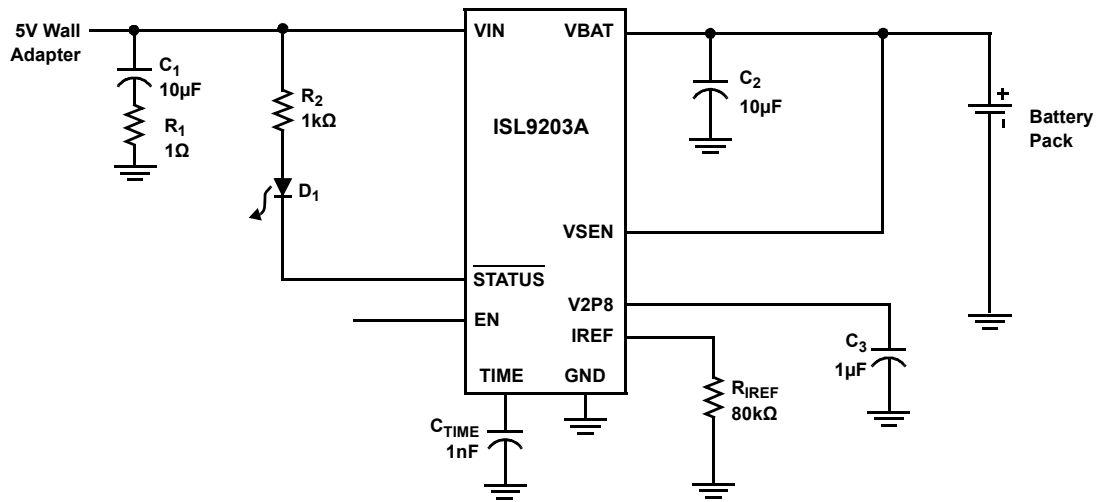

Figure 1. Typical Application Circuit

1. Overview

1.1 Typical Application



1.2 Block Diagram

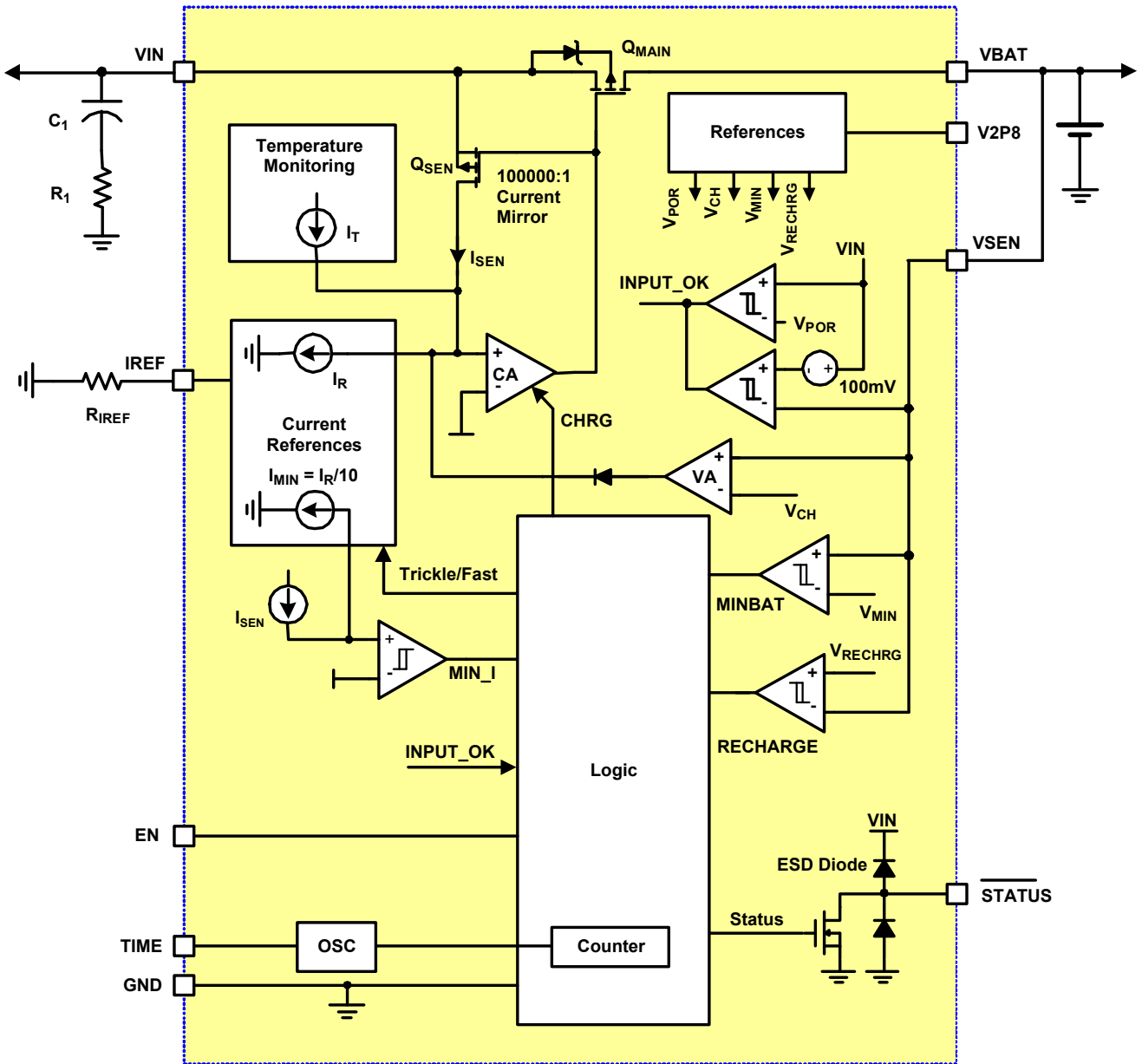

Figure 2. Block Diagram

1.3 Ordering Information

Part Number (Notes 2, 3)	Part Marking	Temp. Range (°C)	Tape and Reel (Units) (Note 1)	Package (RoHS Compliant)	Pkg Dwg. #
ISL9203ACRZ	03AZ	-20 to +70	-	10 Ld 3x3 DFN	L10.3x3
ISL9203ACRZ-T	03AZ	-20 to +70	6k	10 Ld 3x3 DFN	L10.3x3

Notes:

- See [TB347](#) for details about reel specifications.
- Pb-free plus anneal products employ special Pb-free material sets; molding compounds/die attach materials and 100% matte tin plate termination finish, which are RoHS compliant and compatible with both SnPb and Pb-free soldering operations. Pb-free products are MSL classified at Pb-free peak reflow temperatures that meet or exceed the Pb-free requirements of IPC/JEDEC-J STD-020.
- For Moisture Sensitivity Level (MSL), see the [ISL9203A](#) device page. For more information about MSL, see [TB363](#).

1.4 Pin Configuration

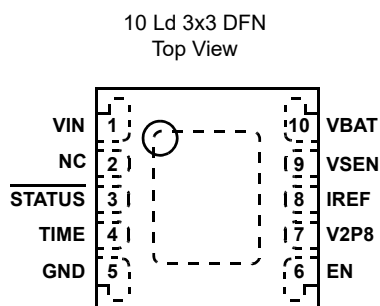

1.5 Pin Descriptions

Pin Number	Pin Name	Description
1	VIN	Input power source. Connect to a wall adapter.
2	NC	No connection.
3	STATUS	Open-drain output indicating the charging and inhibit states. The STATUS pin is pulled LOW when the charger is charging a battery. It is forced to high impedance when the charge current drops to I_{MIN} . This high impedance mode is latched until a recharge cycle or a new charge cycle starts.
4	TIME	Determines the oscillation period by connecting a timing capacitor between this pin and GND. The oscillator also provides a time reference for the charger.
5	GND	Connection to system ground.
6	EN	Enable logic input. Connect the EN pin to LOW to disable the charger or leave it floating to enable the charger.
7	V2P8	2.8V reference voltage output. This pin outputs a 2.8V voltage source when the input voltage is above the POR threshold, otherwise it outputs zero. The V2P8 pin can be used as an indication for adapter presence.
8	IREF	Programming input for the constant charging current. This pin maintains at 0.8V when the charger is in normal operation.
9	VSEN	Remote voltage sense pin. Connect this pin as close as possible to the battery pack positive connection. If the VSEN pin is floating, its voltage drops to 0V and the charger operates in trickle mode.
10	VBAT	Connection to the battery. Typically a 10 μ F tantalum capacitor is needed for stability a battery is not attached. When a battery is attached, only a 0.1 μ F ceramic capacitor is required.

2. Specifications

2.1 Absolute Maximum Ratings

Parameter	Minimum	Maximum	Unit
Supply Voltage (VIN)	-0.3	+7	V
Output Pin Voltage (BAT, VSEN, V2P8)	-0.3	+5.5	V
Signal Input Voltage (TIME, IREF)	-0.3	+3.2	V
Output Pin Voltage (STATUS)	-0.3	+7	V
Charge Current		+1.6	A
ESD Rating	Value		Unit
Human Body Model (Tested per MIL-STD-883 Method 3015.7)	4.5		kV
Machine Model (Tested per EIAJ ED-4701 Method C-111)	200		V

CAUTION: Do not operate at or near the maximum ratings listed for extended periods of time. Exposure to such conditions can adversely impact product reliability and result in failures not covered by warranty.

2.2 Thermal Information

Thermal Resistance (Typical)	θ_{JA} (°C/W)	θ_{JC} (°C/W)
10 Ld 3x3 DFN Package (Notes 4, 5)	46	4

Notes:

- θ_{JA} is measured in free air with the component mounted on a high-effective thermal conductivity test board with “direct attach” features. See [TB379](#).
- For θ_{JC} , the “case temp” location is the center of the exposed metal pad on the package underside. See [TB379](#).

Parameter	Minimum	Maximum	Unit
Maximum Junction Temperature (Plastic Package)		+150	°C
Maximum Storage Temperature Range	-65	+150	°C
Pb-Free Reflow Profile	see TB493		

CAUTION: +150°C max junction temperature is intended for short periods of time to prevent shortening the lifetime. Operation close to +150°C junction may trigger the shutdown of the device even before +150°C because this number is specified as typical.

2.3 Recommended Operation Conditions

Parameter	Minimum	Maximum	Unit
Ambient Temperature Range	-20	+70	°C
Supply Voltage, VIN	4.3	6.5	V

2.4 Electrical Specifications

Typical values are tested at $V_{IN} = 5V$ and +25°C ambient temperature. Maximum and minimum values are ensured across -20°C to +70°C ambient temperature with a supply voltage in the range of 4.3V to 6.5V, unless otherwise noted.

Parameter	Symbol	Test Conditions	Min	Typ	Max	Unit
Power-On Reset						
Rising V_{IN} Threshold			3.0	3.4	4.0	V
Falling V_{IN} Threshold			2.3	2.4	2.65	V
Standby Current						
V _{BAT} Pin Sink Current	$I_{STANDBY}$	V _{IN} floating or EN = LOW	-	-	3.0	μA
V _{IN} Pin Supply Current	I_{VIN}	V _{BAT} floating and EN pulled low	-	30	250	μA

Typical values are tested at $V_{IN} = 5V$ and $+25^{\circ}C$ ambient temperature. Maximum and minimum values are ensured across $-20^{\circ}C$ to $+70^{\circ}C$ ambient temperature with a supply voltage in the range of 4.3V to 6.5V, unless otherwise noted. **(Continued)**

Parameter	Symbol	Test Conditions	Min	Typ	Max	Unit
VIN Pin Supply Current	I_{VIN}	VBAT floating and EN floating	-	1	2	mA
Voltage Regulation						
Output Voltage	V_{CH}		4.158	4.20	4.242	V
Dropout Voltage		VBAT = 3.7V, charge current = 1A	-	320	550	mV
Charge Current						
Constant Charge Current (Note 6)	I_{CHARGE}	$R_{IREF} = 80k\Omega$, $V_{BAT} = 3.7V$	0.9	1.0	1.1	A
Constant Charge Current	I_{CHARGE}	$R_{IREF} = 1.21M\Omega$, $V_{BAT} = 3.7V$	33	66	100	mA
Trickle Charge Current	$I_{TRICKLE}$	$R_{IREF} = 80k\Omega$, $V_{BAT} = 2.0V$	85	110	135	mA
Trickle Charge Current	$I_{TRICKLE}$	$R_{IREF} = 1.21M\Omega$, $V_{BAT} = 2.0V$	2	7	15	mA
End-of-Charge Threshold	I_{MIN}	$R_{IREF} = 80k\Omega$	85	110	135	mA
End-of-Charge Threshold	I_{MIN}	$R_{IREF} = 1.21M\Omega$	2	-	30	mA
Recharge Threshold						
Recharge Voltage Threshold	V_{RECHRG}		3.85	4.00	4.10	V
Trickle Charge Threshold						
Trickle Charge Threshold Voltage	V_{MIN}		2.1	2.3	2.5	V
V2P8 Pin Voltage						
V2P8-Pin Voltage	V_{V2P8}		2.7	2.9	3.1	V
Temperature Monitoring						
Charge Current Foldback Threshold (Note 7)	T_{FOLD}		-	100	-	$^{\circ}C$
Current Foldback Gain (Note 7)	G_{FOLD}		-	100	-	$mA/^{\circ}C$
Oscillator						
Oscillation Period	T_{OSC}	$C_{TIME} = 15nF$	2.4	3.0	3.6	ms
Logic Outputs						
STATUS Logic Low Sink Current		Pin Voltage = 0.8V	5	-	-	mA
STATUS Leakage Current		$V_{VIN} = V_{STATUS} = 5V$	-	-	1	μA
EN Input Logic High			2.0	-	3.3	V
EN Input Logic Low			-	-	0.8	V
EN Pin Current When Driven Low			-	-	100	μA

Notes:

- The accuracy includes all errors except the programming resistance tolerance. The actual charge current may be affected by the thermal foldback function if the thermal dissipation capability is not enough or by the on resistance of the power MOSFET if the charger input voltage is too close to the output voltage.
- Ensured by characterization.

3. Typical Operating Performance

Test conditions: $V_{IN} = 5V$, $T_A = +25^\circ C$, $R_{IREF} = R_{IMIN} = 80k\Omega$, $V_{BAT} = 3.7V$, unless otherwise noted.

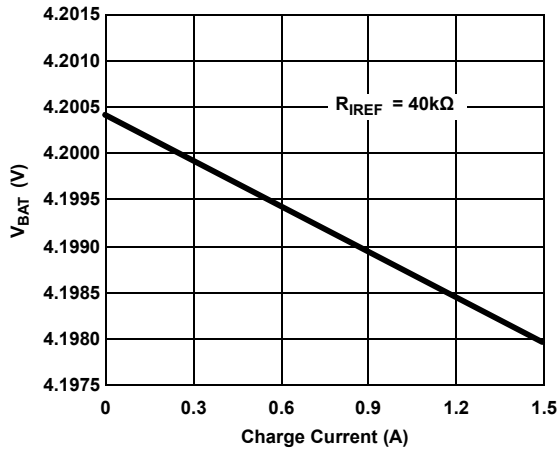

Figure 3. Charger Output Voltage vs Charge Current

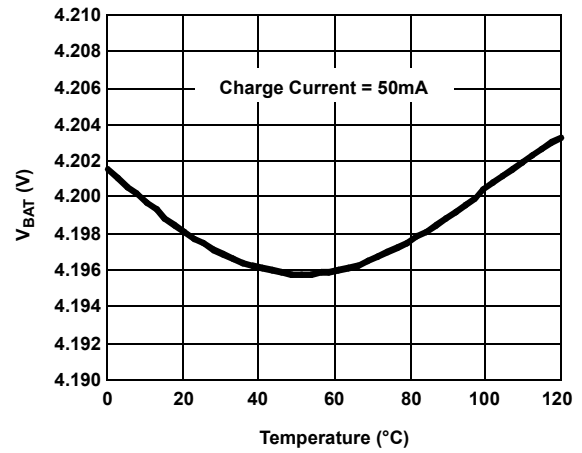

Figure 4. Charger Output Voltage vs Temperature

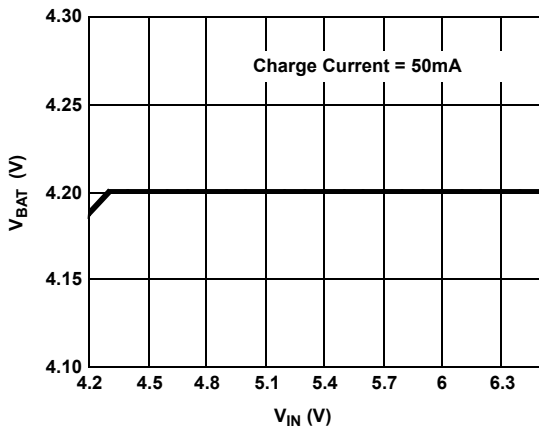

Figure 5. Charger Output Voltage vs Input Voltage
Charge Current is 50mA

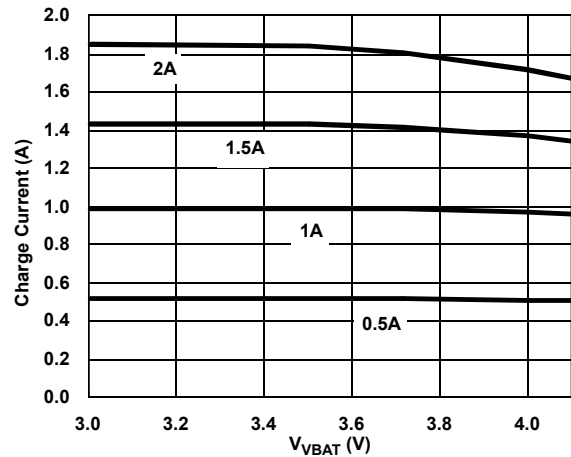

Figure 6. Charge Current vs Output Voltage

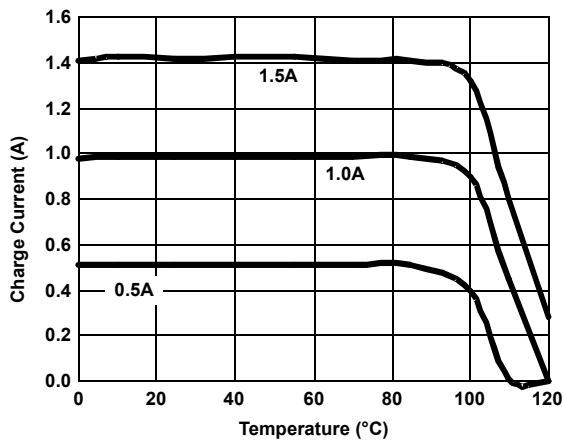

Figure 7. Charge Current vs Ambient Temperature

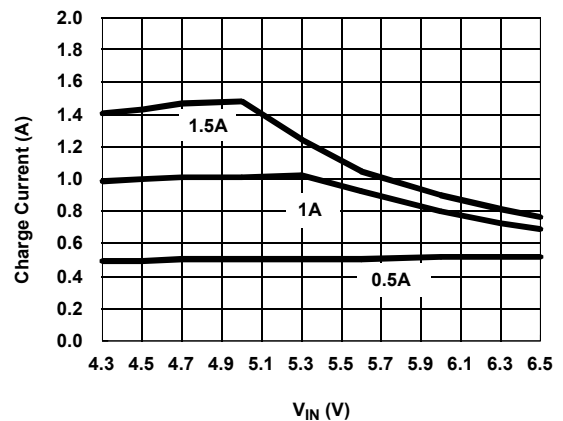

Figure 8. Charge Current vs Input Voltage

Test conditions: $V_{IN} = 5V$, $T_A = +25^\circ C$, $R_{REF} = R_{IMIN} = 80k\Omega$, $V_{BAT} = 3.7V$, unless otherwise noted. (Continued)

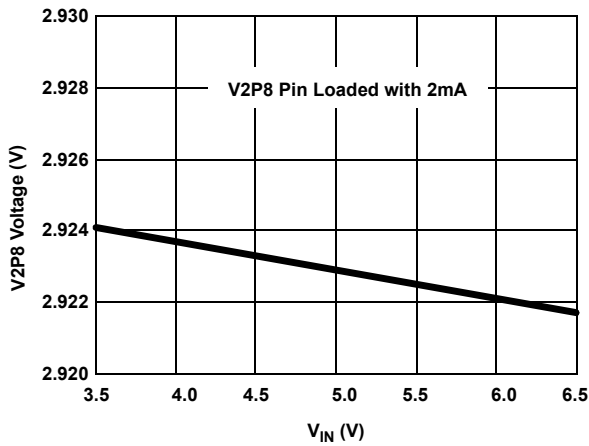

Figure 9. V2P8 Output vs Input Voltage

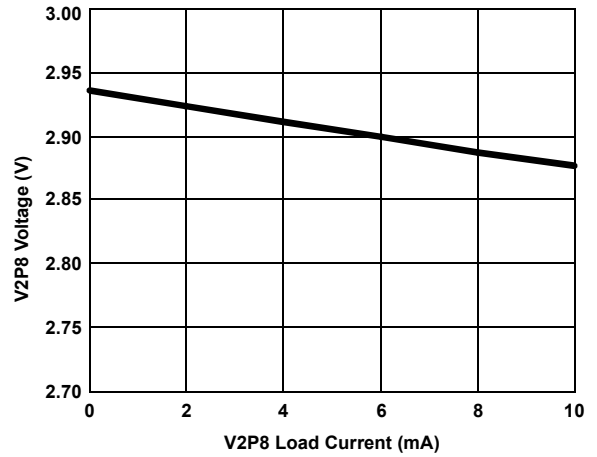

Figure 10. V2P8 Output vs Load Current

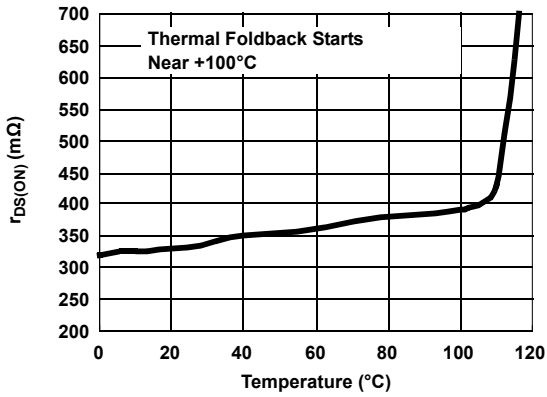

Figure 11. $r_{DS(ON)}$ vs Temperature at 3.7V Output

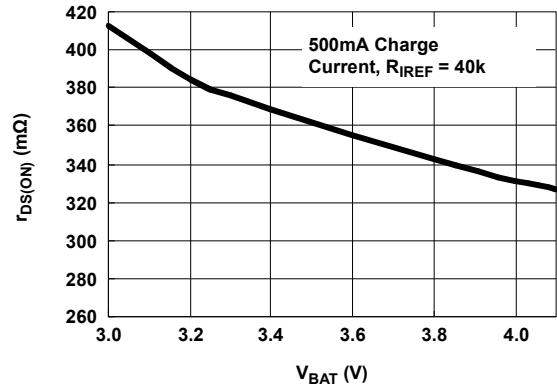

Figure 12. $r_{DS(ON)}$ vs Output Voltage Using Current Limited Adapters

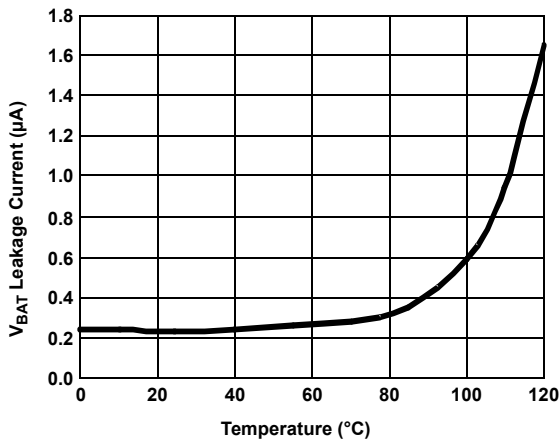

Figure 13. Reverse Current vs Temperature

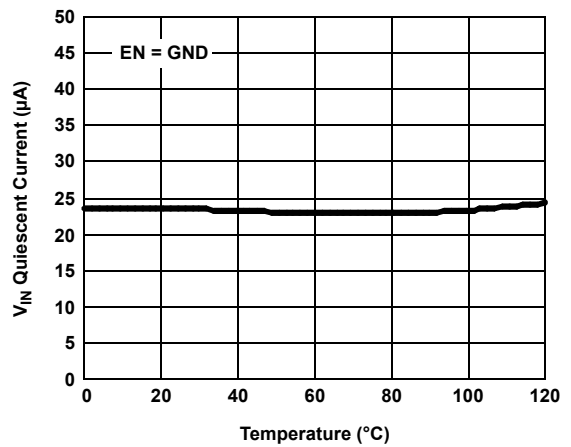

Figure 14. Input Quiescent Current vs Temperature

Test conditions: $V_{IN} = 5V$, $T_A = +25^\circ C$, $R_{REF} = R_{IMIN} = 80k\Omega$, $V_{BAT} = 3.7V$, unless otherwise noted. (Continued)

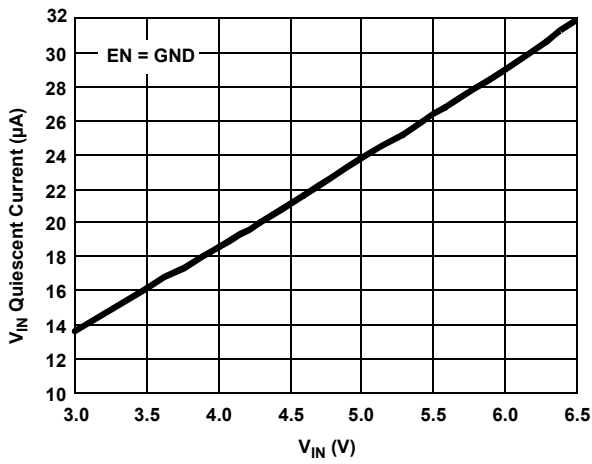

Figure 15. Input Quiescent Current vs Input Voltage When Shut Down

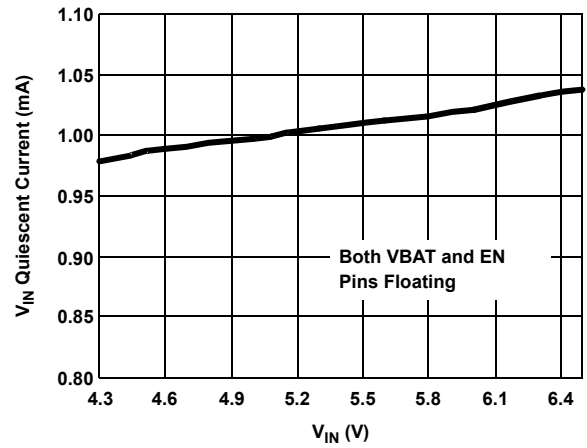

Figure 16. Input Quiescent Current vs Input Voltage When Not Shut Down

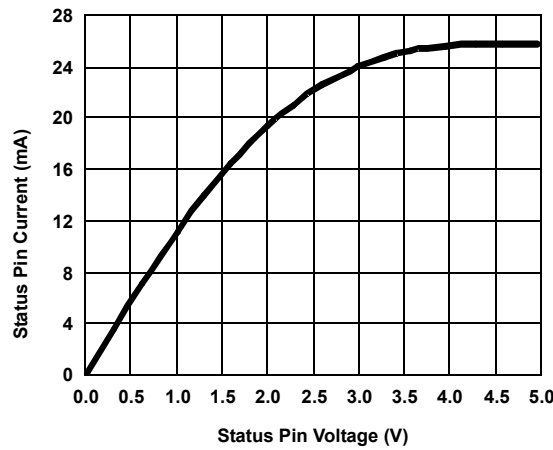

Figure 17. Status Pin Voltage vs Current When the Open-Drive MOSFET Turns On

4. Theory of Operation

The ISL9203A is an integrated charger for single-cell Li-ion or Li-polymer batteries. The ISL9203A functions as a traditional linear charger when powered with a voltage-source adapter. When powered with a current-limited adapter, the charger minimizes the thermal dissipation commonly seen in traditional linear chargers.

As a linear charger, the ISL9203A charges a battery in the popular Constant Current (CC) and Constant Voltage (CV) profile. The constant charge current I_{REF} is programmable up to 1.5A with an external resistor. The charge voltage V_{CH} has 1% accuracy across the entire recommended operating condition range. The charger always preconditions the battery with 10% of the programmed current at the beginning of a charge cycle until the battery voltage is verified to be above the minimum fast charge voltage, V_{MIN} . This low-current preconditioning charge mode is called trickle mode. The verification takes 15 cycles of an internal oscillator with a period that is programmable with the timing capacitor.

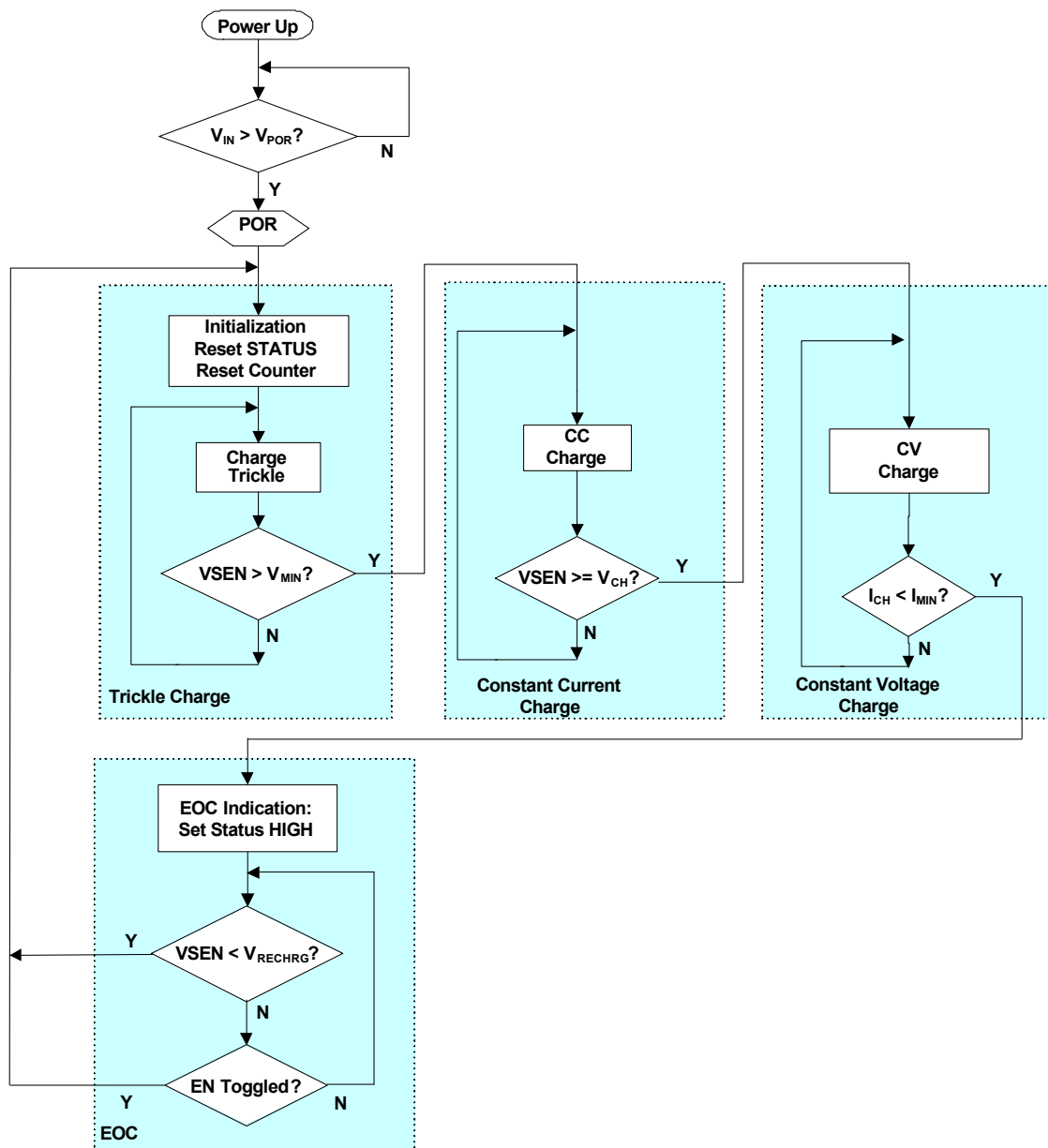

Figure 18. Charging State Diagram

A thermal-foldback feature removes the thermal concern typically seen in linear chargers. The charger reduces the charge current automatically as the IC internal temperature rises above +100°C to prevent further temperature rise. The thermal-foldback feature ensures safe operation when the PCB is space-limited for thermal dissipation.

Two indication pins are available from the charger to indicate the charge status. The V2P8 pin outputs a 2.8V DC voltage when the input voltage is above the Power-On Reset (POR) level and can be used as a power-present indication. The V2P8 pin can source a 2mA current, so it can also be used to bias external circuits. The STATUS pin is an open-drain logic output that goes LOW at the beginning of a charge cycle and stays LOW until the end-of-charge (EOC) condition is qualified. The EOC condition is met when the battery voltage rises above a recharge threshold and the charge current falls below an EOC current threshold. When the EOC condition is qualified, the STATUS output goes HIGH and is latched. The latch is released at the beginning of a recharge cycle, when the EN is toggled, or after the chip is power cycled.

If the ISL9203A has not been power cycled and the EN pin is not toggled, but the VSEN voltage drops below the recharge level, the device re-enters charge mode. In this condition, the charger indicates a recharge cycle by bringing the STATUS pin LOW.

When the wall adapter is not present, the ISL9203A draws less than 1µA of current from the battery.

[Figure 19](#) shows the typical charge curves in a traditional linear charger powered with a constant-voltage adapter.

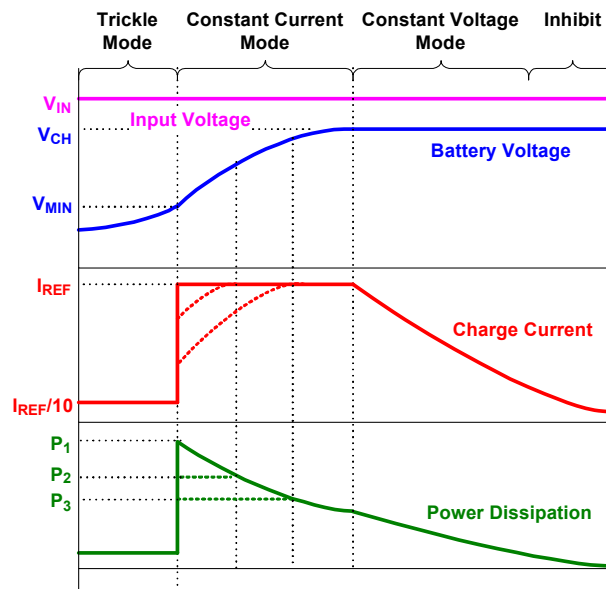

Figure 19. Typical Charge Curves Using a Constant-Voltage Adapter

From the top to bottom, the curves represent the constant input voltage, the battery voltage, the charge current, and the power dissipation in the charger.

The power dissipation P_{CH} is given by the following equation:

$$(EQ. 1) \quad P_{CH} = (V_{IN} - V_{BAT}) \cdot I_{CHARGE}$$

where I_{CHARGE} is the charge current. The maximum power dissipation occurs during the beginning of CC mode. The maximum power the ISL9203A is capable of dissipating is dependent on the thermal impedance of the Printed-Circuit Board (PCB). The dotted lines in [Figure 19](#) show two cases where the charge currents are limited by the maximum power dissipation capability due to the thermal foldback.

When using a current-limited adapter, the thermal situation in the ISL9203A is totally different. [Figure 20](#) shows the typical charge curves when a current-limited adapter is used. The operation requires the I_{REF} to be programmed higher than the limited current I_{LIM} of the adapter, as [Figure 20](#) shows. The key difference of the charger operating under such conditions occurs during CC mode.

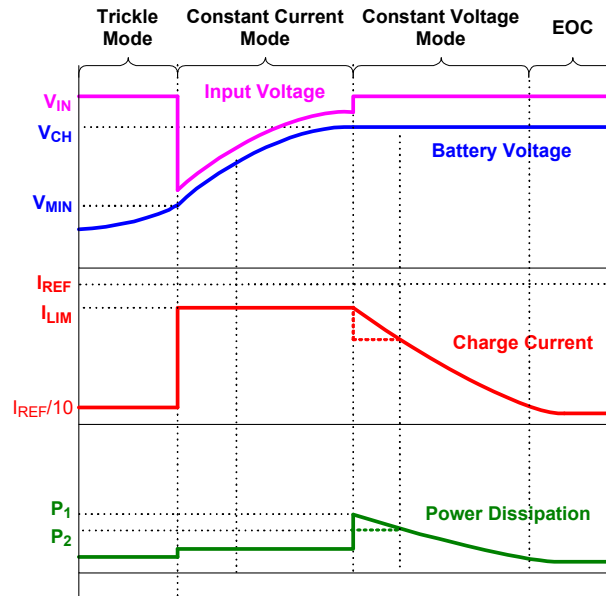

Figure 20. Typical Charge Curves Using a Current Limited Adapter

The block diagram ([Figure 2 on page 3](#)) aids in understanding the operation of the ISL9203A. The current loop consists of the current amplifier CA and the sense MOSFET Q_{SEN} . The current reference I_R is programmed by the I_{REF} pin. The current amplifier CA regulates the gate of the sense MOSFET Q_{SEN} so that the sensed current I_{SEN} matches the reference current I_R . The main MOSFET Q_{MAIN} and the sense MOSFET Q_{SEN} form a current mirror with a ratio of 100000:1; that is, the output charge current is 100,000 times I_R .

In CC mode, the current loop tries to increase the charge current by enhancing the sense MOSFET Q_{SEN} so the sensed current matches the reference current. However, the adapter current is limited, so the actual output current never reaches what is required by the current reference. As a result, the current error amplifier CA keeps enhancing the Q_{SEN} and the main MOSFET Q_{MAIN} until they are fully turned on. Therefore, the main MOSFET becomes a power switch instead of a linear regulation device. The power dissipation in CC mode becomes:

$$(EQ. 2) \quad P_{CH} = r_{DS(ON)} \cdot I_{CHARGE}^2$$

where $r_{DS(ON)}$ is the resistance when the main MOSFET is fully turned on. This power is typically much less than the peak power in the traditional linear mode.

The worst power dissipation when using a current-limited adapter typically occurs at the beginning of the CV mode, as [Figure 20](#) shows. [Equation 1 on page 11](#) applies during the CV mode. When using a very small PCB with a relatively large thermal impedance, it is possible for the internal temperature to reach the thermal foldback threshold. In that case, the IC is thermally protected by lowering the charge current, as shown by the dotted lines in the charge current and power curves in [Figure 20](#). Appropriate adapter design can further reduce the ISL9203A peak power dissipation. See the Application Information section of the [ISL6292 datasheet](#) for more information.

[Figure 21 on page 13](#) shows the typical signal waveforms for the linear charger from power-up to a recharge cycle. See "[Application Information](#)" on [page 13](#) for more detailed application information.

5. Application Information

5.1 Power-On-Reset (POR)

The ISL9203A resets itself as the input voltage rises above the POR rising threshold. The V2P8 pin outputs a 2.8V voltage, the internal oscillator starts to oscillate, the internal timer is reset, and the charger begins to charge the battery. The STATUS pin indicates a LOW logic signal. [Figure 21](#) shows the startup of the charger between t_0 to t_2 .

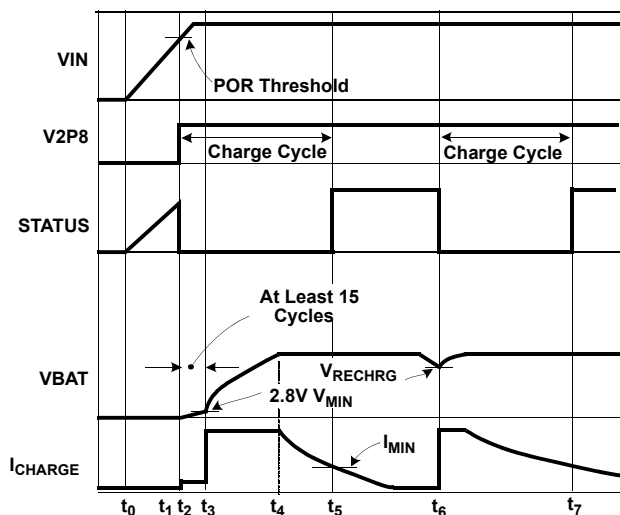

Figure 21. Operation Waveforms

The ISL9203A has a typical rising POR threshold of 3.4V and a falling POR threshold of 2.4V. The 2.4V falling threshold ensures charger operation with a current-limited adapter to minimize the thermal dissipation.

5.2 Charge Cycle

A charge cycle consists of three charge modes:

- Trickle mode
- Constant Current (CC) mode
- Constant Voltage (CV) mode

The charge cycle always starts with trickle mode until the battery voltage stays above V_{MIN} (2.3V typical) for 15 consecutive cycles of the internal oscillator. If the battery voltage drops below V_{MIN} during the 15 cycles, the 15-cycle counter is reset and the charger stays in trickle mode. The charger moves to the CC mode after verifying the battery voltage is above V_{MIN} .

When the battery pack terminal voltage rises to the final charge voltage V_{CH} , CV mode begins. The terminal voltage is regulated at the constant V_{CH} in the CV mode and the charge current declines. After the charge current drops below I_{MIN} (1/10 of I_{REF} , see [“End-of-Charge \(EOC\) Current” on page 15](#) for more detail) the ISL9203A indicates the end-of-charge with the STATUS pin. The charging operation does not terminate. Signals in a charge cycle are shown in [Figure 21](#) between points t_2 and t_5 .

The end of charge indicator (STATUS) is not set if the charging current is below I_{MIN} within the first 16 cycles after V_{BAT} exceeds the V_{RECHRG} voltage. If the charge current is still below I_{MIN} after these 16 cycles, STATUS goes high to indicate end of charge.

The following events initiate a new charge cycle:

- POR
- The battery voltage drops below a recharge threshold
- The EN pin is toggled from GND to floating

See the following sections for more information about these events.

5.3 Recharge

After a charge cycle completes, the charger continues to regulate the output at the constant voltage, but the STATUS pin indicates that the charging is completed. The STATUS pin stays high until the battery voltage drops to below the recharge threshold, V_{RECHRG} (see [“Electrical Specifications” on page 5](#)). The STATUS pin then goes low and a new charge cycle starts at point t_6 . The charge cycle ends at point t_7 with the STATUS pin again going high, as shown in [Figure 21 on page 13](#).

5.4 Internal Oscillator

The internal oscillator establishes a timing reference. The oscillation period is programmable with an external timing capacitor, C_{TIME} , as shown in [“Typical Application” on page 2](#). The oscillator charges the timing capacitor to 1.5V and discharges it to 0.5V in one period, both with 10 μ A current. The period T_{OSC} is:

$$(EQ. 3) \quad T_{OSC} = 0.2 \cdot 10^6 \cdot C_{TIME} \quad (\text{seconds})$$

A 1nF capacitor results in a 0.2ms oscillation period. The accuracy of the period is mainly dependent on the accuracy of the capacitance and the internal current source.

5.5 Charge Current Programming

The charge current in the CC mode is programmed by the IREF pin. The voltage of IREF is regulated to a 0.8V reference voltage. The charging current during the constant current mode is 100000 times that of the current in the R_{IREF} resistor. Therefore, the charge current is:

$$(EQ. 4) \quad I_{REF} = \frac{0.8V}{R_{IREF}} \times 10^5 \text{ (A)}$$

[Table 1](#) shows the charge current vs selected R_{IREF} values. The typical trickle charge current is 10% of the programmed constant charge current.

Table 1. Charge Current vs R_{IREF} Values

R_{IREF} (k Ω)	Charge Current (mA)		
	Min	Typ	Max
267 ~ 160	17% lower than Typ value	= I_{REF} in Equation 5 on page 15	17% higher than Typ value
160	450	500	550
100	720	800	880
88.9	810	900	990
80	900	1000	1100

[Table 2](#) shows the trickle charge current tolerance guidance at given R_{IREF} values, when the battery voltage is between 0V and 2.5V.

Table 2. Trickle Charge Current vs R_{IREF} Values

R_{IREF} (k Ω)	Trickle Charge Current (mA)		
	Min	Typ	Max
267	15	30	60
160	30	50	80
100	40	80	120
88.9	45	90	135
80	70	100	150

Note:

8. The values in [Tables 1](#) and [2](#) are not tested and are only for guidance in selecting resistor values for mass production tests or in customer's products.

5.6 End-of-Charge (EOC) Current

The EOC current I_{MIN} sets the level at which the charger starts to indicate the end of the charge with the STATUS pin, as shown in [Figure 21 on page 13](#). The charger does not actually terminate charging. In the ISL9203A, the EOC current is internally set to 1/10 of the CC charge current, that is:

$$(EQ. 5) \quad I_{MIN} = \frac{1}{10} \cdot I_{REF}$$

At the EOC, the STATUS signal rises to HIGH and is latched. The latch is not reset until a recharge cycle or a new charge cycle starts. The tolerance guidance for the EOC current at selected R_{IREF} values are given in [Table 3](#).

Table 3. EOC Current vs R_{IREF} Values

R_{IREF} (k Ω)	EOC Current (mA)		
	Min	Typ	Max
267	15	30	60
160	30	50	80
100	40	80	120
88.9	45	90	135
80	70	100	150

Note:

9. The values in this table are not tested and are only for guidance in selecting resistor values for mass production tests or in customer's products.

5.7 Charge Current Thermal Foldback

Overheating is always a concern in a linear charger. The maximum power dissipation usually occurs at the beginning of a charge cycle when the battery voltage is at its minimum but the charge current is at its maximum. The ISL9203A's charge current thermal foldback function prevents overheating.

[Figure 22 on page 16](#) shows the current signals at the summing node of the current error amplifier CA in the block diagram.

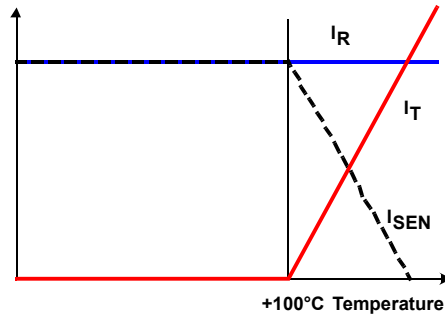

Figure 22. Current Signals at the Amplifier CA Input

I_R is the reference and I_T is the current from the Temperature Monitoring block. I_T has no impact on the charge current until the internal temperature reaches approximately $+100^\circ\text{C}$; then I_T rises at a rate of $1\mu\text{A}/^\circ\text{C}$. When I_T rises, the current control loop forces the sensed current I_{SEN} to reduce at the same rate. As a mirrored current, the charge current is 100000 times that of the sensed current and reduces at a rate of $100\text{mA}/^\circ\text{C}$. For a charger with the constant charge current set at 1A, the charge current is reduced to zero when the internal temperature rises to $+110^\circ\text{C}$. The actual charge current settles between $+100^\circ\text{C}$ to $+110^\circ\text{C}$.

The charge current should not drop below I_{MIN} because of the thermal foldback. If the charge current does drop below I_{MIN} in extreme cases, the charger does not indicate end-of-charge unless the battery voltage is already above the recharge threshold.

5.8 2.8V Bias Voltage

The ISL9203A provides a 2.8V voltage for biasing the internal control and logic circuit. This voltage is also available for external circuits such as the NTC thermistor circuit. The maximum allowed external load is 2mA.

5.9 Indications

The ISL9203A has two indications: the input presence and the charge status. The input presence is indicated by the V2P8 pin and the charge status is indicated by the STATUS pin. [Figure 23](#) shows the V2P8 pin voltage vs the input voltage.

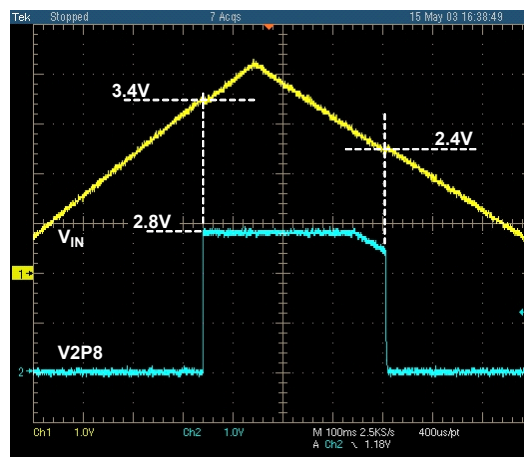

Figure 23. V2P8 Pin Output vs Input Voltage at the VIN Pin.
Vertical: 1V/Div, Horizontal: 100ms/Div

5.10 STATUS Pull-Up Resistor

The STATUS pin is an open-drain output that needs an external pull-up resistor. Renesas recommends pulling this pin up to the input voltage or the 2.8V from the V2P8 pin. If the STATUS pin has to be pulled up to other voltages, carefully examine whether the ESD diodes form a leakage current path to the battery when the input power is removed. If the leakage path does exist, an external transistor is required to break the path.

Figure 24 shows the implementation of the pull-up circuit. If the STATUS pin is directly pulled up to the V_{CC} voltage (not shown in Figure 24), a current flows from V_{CC} to the STATUS pin, then through the ESD diode to the VIN pin. Any leakage on the VIN pin caused by an external or internal current path results in a current path from V_{CC} to ground.

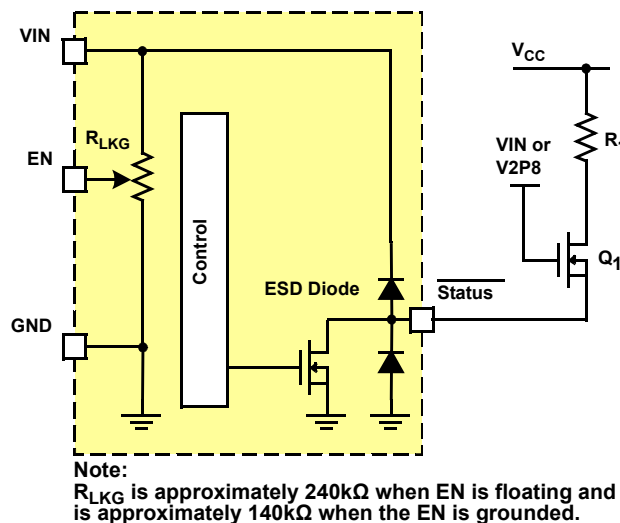

Figure 24. Pull-Up Circuit to Avoid Battery Leakage Current in the ESD Diodes

The N-Channel MOSFET Q_1 buffers the STATUS pin. The Q_1 gate is connected to VIN or the V2P8 pin. When the STATUS pin outputs a logic low signal, Q_1 is turned on and its drain outputs a low signal as well. When STATUS is high impedance, R_1 pulls the Q_1 drain to high. When the input power is removed, the Q_1 gate voltage is also removed, so the Q_1 drain stays high.

5.11 Shutdown

The ISL9203A can be shut down by pulling the EN pin to ground. When shut down, the charger draws typically less than 30 μ A current from the input power and the 2.8V output at the V2P8 pin is also turned off. The EN pin must be driven with an open-drain or open-collector logic output, so that the EN pin is floating when the charger is enabled. If the EN pin is driven by an external source, the POR threshold voltage is affected.

5.12 Input and Output Capacitor Selection

Due to the inductance of the power leads of the wall adapter or USB source, the input capacitor type must be properly selected to prevent high voltage transient during a hot-plug event. A tantalum capacitor is a good choice for its high ESR and provides damping to the voltage transient. However, multi-layer ceramic capacitors have a very low ESR; when used as input capacitors, you must use a 1 Ω series resistor to provide adequate damping, as shown in Figure 1 on page 1.

The output capacitor can be any ceramic type with the value higher than 0.1 μ F. However, if there is a chance the charger will be used as an LDO linear regulator, a 10 μ F tantalum capacitor is recommended.

Note: The charger always steps through the 15-cycle V_{MIN} verification time before the charge current rises to the constant charge current. Therefore, when the system is used as an LDO, it should not load the charger heavily until the 15-cycle verification is complete.

5.13 Working with Current-Limited Adapters

The ISL9203A can work with a current-limited adapter to significantly reduce the thermal dissipation during charging. See the [ISL6292 datasheet](#) for more details.

5.14 Board Layout Recommendations

The ISL9203A internal thermal foldback function limits the charge current when the internal temperature reaches approximately +100°C. To maximize the current capability, it is very important that the exposed pad under the package is properly soldered to the board and is connected to other layers through thermal vias. More thermal vias and more copper attached to the exposed pad usually result in better thermal performance. However, the number of vias is limited by the size of the pad. The 3x3 DFN package allows eight vias to be placed in two rows. Because the pins on the 3x3 DFN package are on only two sides, connect as much top layer copper as possible to the exposed pad to minimize the thermal impedance. See the [ISL6292 evaluation boards](#) for layout examples.

6. Revision History

Rev.	Date	Description
1.00	Jun.14.19	<p>Updated Related Literature section. Updated links throughout document. Updated ordering information table on page 4: Corrected part marking numbers. Added Tape and Reel quantity column. Added MSL note. Added revision history. Updated package outline drawing from revision 3 to revision 11. Changes are as follows: -Revision 3: POD created from L10.3X3 -Revision 4: Added Typical Recommended Land Pattern -Revision 5: New Revision, Converted to newer standard -Revision 6: Changed Note 4 from "Dimension b applies..." to "Lead width applies..." Changed Note callout in Detail X from 4 to 5 Changed height in side view from 0.90 MAX to 1.00 MAX Added Note 4 callout next to lead width in Bottom View In Land Pattern, corrected lead shape for 4 corner pins to "L" shape (was rectangular and did not match bottom view) -Revision 7: Removed package outline and included center to center distance between lands on recommended land pattern. Removed Note 4 "Dimension b applies to the metallized terminal and is measured between 0.18mm and 0.30mm from the terminal tip." since it is not applicable to this package. Renumbered notes accordingly. -Revision 8: Corrected L-shaped leads in Bottom view and land pattern so that they align with the rest of the leads (L shaped leads were shorter) -Revision 9: Added missing dimension 0.415 in Typical Recommended land pattern. -Revision 10: Shortened the e-pad rectangle on both the recommended land pattern and the package bottom view to line up with the centers of the corner pins. -Revision 11: Tiebar Note 4 updated From: Tiebar shown (if present) is a non-functional feature. To: Tiebar shown (if present) is a non-functional feature and may be located on any of the 4 sides (or ends). Applied new template.</p>

7. Package Outline Drawing

For the most recent package outline drawing, see [L10.3x3](#).

L10.3x3
 10 LEAD DUAL FLAT PACKAGE (DFN)
 Rev 11, 3/15

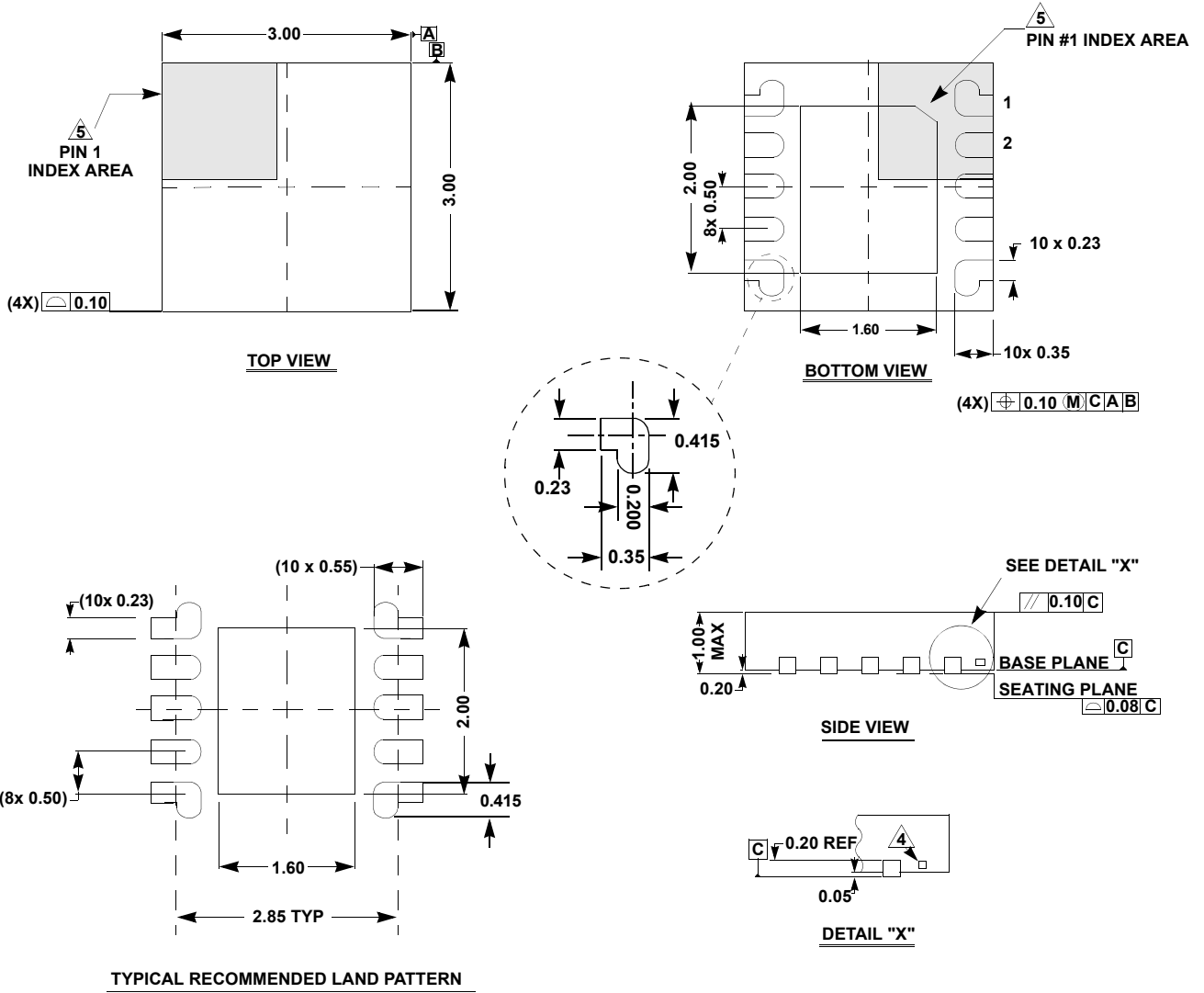

NOTES:

1. Dimensions are in millimeters.
 Dimensions in () for Reference Only.
2. Dimensioning and tolerancing conform to ASME Y14.5m-1994.
3. Unless otherwise specified, tolerance : Decimal ± 0.05
4. Tiebar shown (if present) is a non-functional feature and may be located on any of the 4 sides (or ends).
5. The configuration of the pin #1 identifier is optional, but must be located within the zone indicated. The pin #1 identifier may be either a mold or mark feature.

Notice

1. Descriptions of circuits, software and other related information in this document are provided only to illustrate the operation of semiconductor products and application examples. You are fully responsible for the incorporation or any other use of the circuits, software, and information in the design of your product or system. Renesas Electronics disclaims any and all liability for any losses and damages incurred by you or third parties arising from the use of these circuits, software, or information.
2. Renesas Electronics hereby expressly disclaims any warranties against and liability for infringement or any other claims involving patents, copyrights, or other intellectual property rights of third parties, by or arising from the use of Renesas Electronics products or technical information described in this document, including but not limited to, the product data, drawings, charts, programs, algorithms, and application examples.
3. No license, express, implied or otherwise, is granted hereby under any patents, copyrights or other intellectual property rights of Renesas Electronics or others.
4. You shall not alter, modify, copy, or reverse engineer any Renesas Electronics product, whether in whole or in part. Renesas Electronics disclaims any and all liability for any losses or damages incurred by you or third parties arising from such alteration, modification, copying or reverse engineering.
5. Renesas Electronics products are classified according to the following two quality grades: "Standard" and "High Quality". The intended applications for each Renesas Electronics product depends on the product's quality grade, as indicated below.
 - "Standard": Computers; office equipment; communications equipment; test and measurement equipment; audio and visual equipment; home electronic appliances; machine tools; personal electronic equipment; industrial robots; etc.
 - "High Quality": Transportation equipment (automobiles, trains, ships, etc.); traffic control (traffic lights); large-scale communication equipment; key financial terminal systems; safety control equipment; etc.Unless expressly designated as a high reliability product or a product for harsh environments in a Renesas Electronics data sheet or other Renesas Electronics document, Renesas Electronics products are not intended or authorized for use in products or systems that may pose a direct threat to human life or bodily injury (artificial life support devices or systems; surgical implantations; etc.), or may cause serious property damage (space system; undersea repeaters; nuclear power control systems; aircraft control systems; key plant systems; military equipment; etc.). Renesas Electronics disclaims any and all liability for any damages or losses incurred by you or any third parties arising from the use of any Renesas Electronics product that is inconsistent with any Renesas Electronics data sheet, user's manual or other Renesas Electronics document.
6. When using Renesas Electronics products, refer to the latest product information (data sheets, user's manuals, application notes, "General Notes for Handling and Using Semiconductor Devices" in the reliability handbook, etc.), and ensure that usage conditions are within the ranges specified by Renesas Electronics with respect to maximum ratings, operating power supply voltage range, heat dissipation characteristics, installation, etc. Renesas Electronics disclaims any and all liability for any malfunctions, failure or accident arising out of the use of Renesas Electronics products outside of such specified ranges.
7. Although Renesas Electronics endeavors to improve the quality and reliability of Renesas Electronics products, semiconductor products have specific characteristics, such as the occurrence of failure at a certain rate and malfunctions under certain use conditions. Unless designated as a high reliability product or a product for harsh environments in a Renesas Electronics data sheet or other Renesas Electronics document, Renesas Electronics products are not subject to radiation resistance design. You are responsible for implementing safety measures to guard against the possibility of bodily injury, injury or damage caused by fire, and/or danger to the public in the event of a failure or malfunction of Renesas Electronics products, such as safety design for hardware and software, including but not limited to redundancy, fire control and malfunction prevention, appropriate treatment for aging degradation or any other appropriate measures. Because the evaluation of microcomputer software alone is very difficult and impractical, you are responsible for evaluating the safety of the final products or systems manufactured by you.
8. Please contact a Renesas Electronics sales office for details as to environmental matters such as the environmental compatibility of each Renesas Electronics product. You are responsible for carefully and sufficiently investigating applicable laws and regulations that regulate the inclusion or use of controlled substances, including without limitation, the EU RoHS Directive, and using Renesas Electronics products in compliance with all these applicable laws and regulations. Renesas Electronics disclaims any and all liability for damages or losses occurring as a result of your noncompliance with applicable laws and regulations.
9. Renesas Electronics products and technologies shall not be used for or incorporated into any products or systems whose manufacture, use, or sale is prohibited under any applicable domestic or foreign laws or regulations. You shall comply with any applicable export control laws and regulations promulgated and administered by the governments of any countries asserting jurisdiction over the parties or transactions.
10. It is the responsibility of the buyer or distributor of Renesas Electronics products, or any other party who distributes, disposes of, or otherwise sells or transfers the product to a third party, to notify such third party in advance of the contents and conditions set forth in this document.
11. This document shall not be reprinted, reproduced or duplicated in any form, in whole or in part, without prior written consent of Renesas Electronics.
12. Please contact a Renesas Electronics sales office if you have any questions regarding the information contained in this document or Renesas Electronics products.

(Note1) "Renesas Electronics" as used in this document means Renesas Electronics Corporation and also includes its directly or indirectly controlled subsidiaries.

(Note2) "Renesas Electronics product(s)" means any product developed or manufactured by or for Renesas Electronics.

(Rev.4.0-1 November 2017)

Corporate Headquarters

TOYOSU FORESIA, 3-2-24 Toyosu,
Koto-ku, Tokyo 135-0061, Japan
www.renesas.com

Contact Information

For further information on a product, technology, the most up-to-date version of a document, or your nearest sales office, please visit:
www.renesas.com/contact/

Trademarks

Renesas and the Renesas logo are trademarks of Renesas Electronics Corporation. All trademarks and registered trademarks are the property of their respective owners.





Looking for pricing, stock, or lifecycle information?

Click below to explore more details on WIN SOURCE:

 [View ISL9203ACRZ on WIN SOURCE](#)

 [Intersil Information](#)

Optimize Your Supply Chain with WIN SOURCE Solutions

-  Global Sourcing Solution
-  Obsolete Management
-  Cost Control Management
-  Shortage Management
-  Alternative Solution
-  Excess Inventory Management