



**THE DATASHEET OF
ISL90462UIH627Z-TK**



ISL90462

Single Volatile 32-tap XDCP Digitally Controlled Potentiometer (XDCP™)

FN8230
Rev 4.00
October 20, 2015

The Intersil ISL90462 is a digitally controlled potentiometer (XDCP). Configured as a variable resistor, the device consists of a resistor array, wiper switches, a control section, and volatile memory. The wiper position is controlled by a 2-pin Up /Down interface.

The potentiometer is implemented by a resistor array composed of 31 resistive elements and a wiper switching network. Between each element and at either end are tap points accessible to the wiper terminal. The position of the wiper element is controlled by the \overline{CS} and U/\overline{D} inputs.

The device can be used in a wide variety of applications including:

- LCD contrast control
- Parameter and bias adjustments
- Industrial and Automotive Control
- Transducer adjustment of pressure, temperature, position, chemical, and optical sensors
- Laser Diode driver biasing
- Gain control and offset adjustment

Features

- Volatile Solid-State Potentiometer
- 2-pin UP/DN Interface
- DCP Terminal Voltage, 2.7V to 5.5V
- Tempco 35ppm/°C Typical
- 32 Wiper Tap Points
- Low Power CMOS
 - Active current, 25µA max.
 - Supply current 0.3µA
- Available R_{TOTAL} Values = 10kΩ, 50kΩ, 100kΩ
- Temperature Range -40°C to +85°C
- Packages
 - 6 Ld SC-70, SOT-23
- Pb-Free Plus Anneal Available (RoHS Compliant)

Pinout

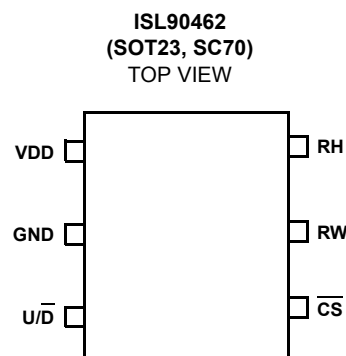

Ordering Information

PART NUMBER	PART MARKING	R_{TOTAL} (K)	TEMP RANGE (°C)	PACKAGE (Tape and Reel)	PKG. DWG. #
ISL90462WIE627Z-TK (See Note)	DEK	10	-40 to +85	6 Ld SC-70 (Pb-free)	P6.049
ISL90462WIH627Z-TK (See Note)	DEL		-40 to +85	6 Ld SOT-23 (Pb-free)	P6.064
ISL90462UIE627Z-TK (See Note)	DEI	50	-40 to +85	6 Ld SC-70 (Pb-free)	P6.049
ISL90462UIH627Z-TK (See Note)	DEJ		-40 to +85	6 Ld SOT-23 (Pb-free)	P6.064
ISL90462TIE627Z-TK (See Note)	DEG	100	-40 to +85	6 Ld SC-70 (Pb-free)	P6.049
ISL90462TIH627Z-TK (See Note) (No longer available, recommended replacement: SL90462UIE627Z-TK)	DEH		-40 to +85	6 Ld SOT-23 (Pb-free)	P6.064

NOTE: Intersil Pb-free plus anneal products employ special Pb-free material sets; molding compounds/die attach materials and 100% matte tin plate termination finish, which are RoHS compliant and compatible with both SnPb and Pb-free soldering operations. Intersil Pb-free products are MSL classified at Pb-free peak reflow temperatures that meet or exceed the Pb-free requirements of IPC/JEDEC J STD-020

Block Diagram

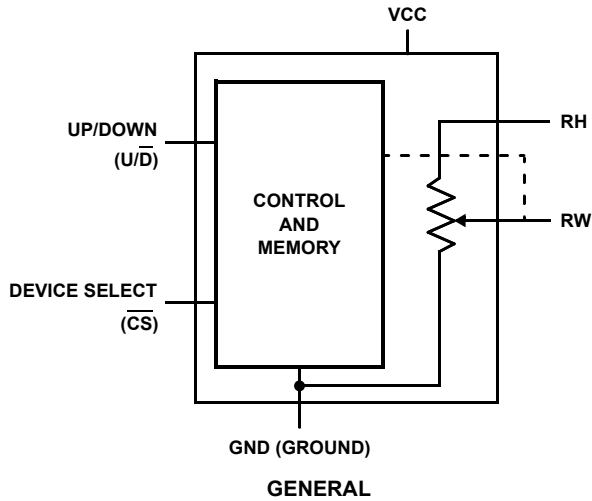

Pin Descriptions

6-PIN	SYMBOL	DESCRIPTION
1	VDD	Supply voltage
2	GND	Ground/Low terminal
3	U/\bar{D}	Up - Down
4	CS	Chip select
5	RW	Wiper terminal
6	RH	High terminal

Absolute Maximum Ratings

Storage Temperature -65°C to +150°C
 Voltage on CS, U/D and VCC With Respect to GND . . . -1V to +7V
 Lead Temperature (soldering 10s) 300°C
 I_W (10s) ±6mA
 Power Rating 1mW

Recommended Operating Conditions

Temperature Range (Industrial) -40°C to 85°C
 V_{CC} 2.7V to 5.5V

CAUTION: Stresses above those listed under "Absolute Maximum Ratings" may cause permanent damage to the device. This is a stress rating only; functional operation of the device (at these or any other conditions above those listed in the operational sections of this specification) is not implied. Exposure to absolute maximum rating conditions for extended periods may affect device reliability.

Potentiometer Specifications

Over recommended operating conditions unless otherwise stated.

SYMBOL	PARAMETER	TEST CONDITIONS	MIN	TYP (Note 4)	MAX	UNIT
R_{TOT}	End to end resistance	W version	8	10	12	kΩ
		U version	40	50	60	kΩ
		T version	80	100	120	kΩ
V_R	RH, R_L terminal voltages		0		V_{CC}	V
	Noise	Ref: 1kHz		-120		dBV
R_W	Wiper Resistance			600		Ω
I_W	Wiper Current				0.6	mA
	Resolution		1		32	Taps
	Absolute linearity (Note 1)	$R_{H(n)}(\text{actual}) - R_{H(n)}(\text{expected})$			±1	MI (Note 3)
	Relative linearity (Note 2)	$R_{H(n+1)} - [R_{H(n)} + MI]$			±0.5	MI (Note 3)
	R_{TOTAL} temperature coefficient			±35		ppm/°C
$C_H/C_L/C_W$	Potentiometer capacitances	See Equivalent Circuit		10/10/25		pF

NOTES:

- Absolute linearity is utilized to determine actual wiper voltage versus expected voltage = $(R_{H(n)}(\text{actual}) - R_{H(n)}(\text{expected})) = \pm 1$ MI Maximum. $n = 1 \dots 29$ only
- Relative linearity is a measure of the error in step size between taps = $R_{H(n+1)} - [R_{H(n)} + MI] = \pm 0.5$ MI, $n = 1 \dots 29$ only.
- 1 MI = Minimum Increment = $R_{TOTAL}/31$.
- Typical values are for $T_A = 25^\circ\text{C}$ and nominal supply voltage.

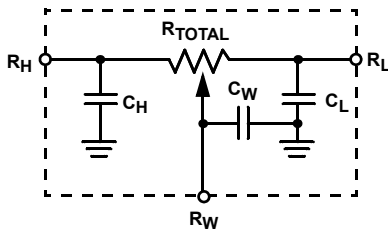
Equivalent Circuit

DC Electrical Specifications Over recommended operating conditions unless otherwise specified.

SYMBOL	PARAMETER	TEST CONDITIONS	MIN	TYP (NOTE 4)	MAX	UNIT
I_{CC}	V_{CC} active current (Increment)	$\overline{CS} = 0V$, $U/\overline{D} = f_{clock} = 1MHz$ and $V_{CC} = 3V$			25	μA
I_{SB}	Standby supply current	$\overline{CS} = V_{CC}$, $U/\overline{D} = GND$ or $V_{CC} = 3V$		0.3	1	μA
I_{LI}	CS input leakage current	$V_{IN} = GND$ to V_{CC}			± 1	μA
V_{IH}	\overline{CS} , U/\overline{D} input HIGH voltage		$V_{CC} \times 0.7$			V
V_{IL}	\overline{CS} , U/\overline{D} input LOW voltage				$V_{CC} \times 0.3$	V
C_{IN}	\overline{CS} , U/\overline{D} input capacitance	$V_{CC} = 3V$, $V_{IN} = GND$, $T_A = 25^\circ C$, $f = 1MHz$		10		pF

Timing Specifications Over recommended operating conditions unless otherwise specified

SYMBOL	PARAMETER	MIN	TYP (Note 4)	MAX	UNIT
t_{CU}	U/\overline{D} to \overline{CS} setup	25			ns
t_{CI}	\overline{CS} to U/\overline{D} setup	50			ns
t_{IC}	\overline{CS} to U/\overline{D} hold	25			ns
t_{IL}	U/\overline{D} LOW period	300			ns
t_{IH}	U/\overline{D} HIGH period	300			ns
f_{TOGGLE}	Up/Down toggle Rate		1		MHz
t_{SETTLE}	Output settling time		1		μs

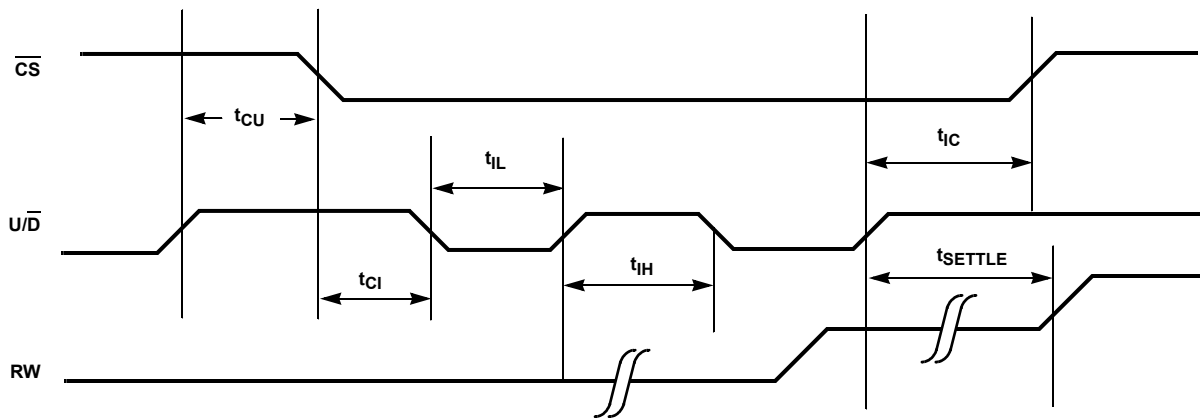

FIGURE 1. SERIAL INTERFACE TIMING DIAGRAM, INCREMENT

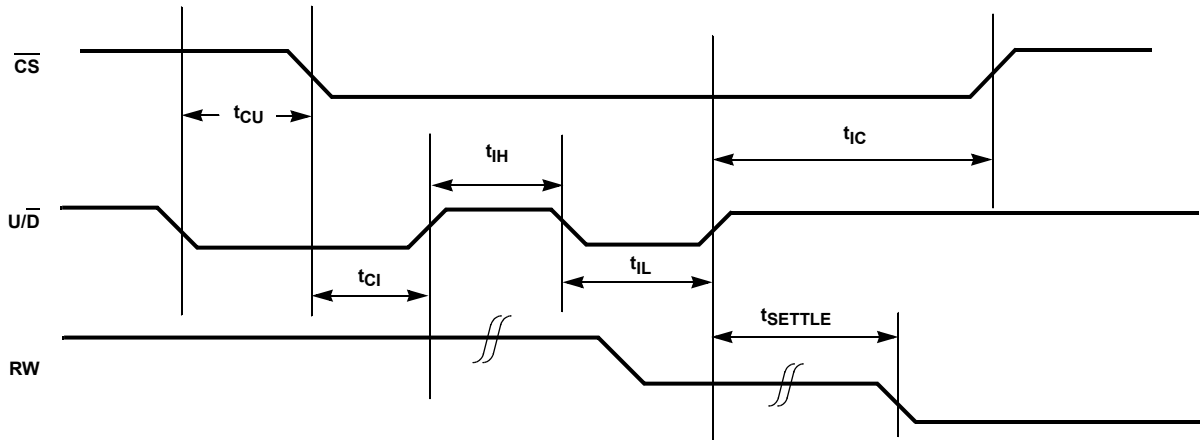

FIGURE 2. SERIAL INTERFACE TIMING DIAGRAM DECREMENT

Pin Descriptions

RH and RW

The ISL90462 contains a digital potentiometer with one terminal tied to the ground pin (GND) of the device. The RH pin is the other potentiometer terminal, and the RW pin is the wiper terminal. The position of the wiper is controlled by the \overline{CS} - and U/\overline{D} - inputs, with a movement "up" connecting the wiper closer to the RH pin, and movement "down" connection the wiper closer to the GND pin.

Up/Down (U/\overline{D})

The U/\overline{D} input controls the direction of the wiper movement and whether the counter is incremented or decremented.

Chip Select (\overline{CS})

The device is selected when the \overline{CS} input is LOW. The current counter value is stored in volatile memory when \overline{CS} is returned HIGH. When \overline{CS} is high, the device is placed in low power standby mode.

Principles of Operation

There are two sections of the ISL90462: the input control, counter and decode section; and the resistor array. The input control section operates just like an up/down counter. The output of this counter is decoded to turn on a single electronic switch connecting a point on the resistor array to the wiper output. The resistor array is comprised of 31 individual resistors connected in series. At either end of the array and between each resistor is an electronic switch that transfers the connection at that point to the wiper. The RH and RW terminals are uncommitted, and can for a variable voltage divider if RH is connected to a voltage source.

The direction of the wiper movement is defined when the device is selected. If during \overline{CS} transition from High to Low the U/\overline{D} input is LOW, the wiper will move down on each rising edge of U/\overline{D} toggling. Similarly, the wiper will move up on each rising edge of U/\overline{D} toggling if, during \overline{CS} transition from High to Low, the U/\overline{D} input is High.

The wiper, when at either fixed terminal, acts like its mechanical equivalent and does not move beyond the last position. That is, the counter does not wrap around when clocked to either extreme.

If the wiper is moved several positions, multiple taps are connected to the wiper for t_{SETTLE} (U/\overline{D} to RW change). The 2-terminal resistance value for the device can temporarily change by a significant amount if the wiper is moved several positions.

Revision History

The revision history provided is for informational purposes only and is believed to be accurate, but not warranted. Please go to the web to make sure that you have the latest revision.

DATE	REVISION	CHANGE
October 20, 2015	FN8230.4	<ul style="list-style-type: none"> - Updated Ordering Information Table on page 1. - Added Revision History. - Added About Intersil Verbiage. - Updated POD P6.064 to latest revision changes are as follow: Update to new format (same dimensions, added land pattern and moved dimensions from table onto drawing) - Updated POD P6.049 to latest revision changes are as follow: Added pin 1 cross-hatched index area to top view. Added Note 8, it reference to Pin 1 Index Area. A2 minimum measurement changed from 0.00 to 0.79.

About Intersil

Intersil Corporation is a leading provider of innovative power management and precision analog solutions. The company's products address some of the largest markets within the industrial and infrastructure, mobile computing and high-end consumer markets.

For the most updated datasheet, application notes, related documentation and related parts, please see the respective product information page found at www.intersil.com.

You may report errors or suggestions for improving this datasheet by visiting www.intersil.com/ask.

Reliability reports are also available from our website at www.intersil.com/support.

Package Outline Drawing

P6.064

6 LEAD SMALL OUTLINE TRANSISTOR PLASTIC PACKAGE

Rev 4, 2/10

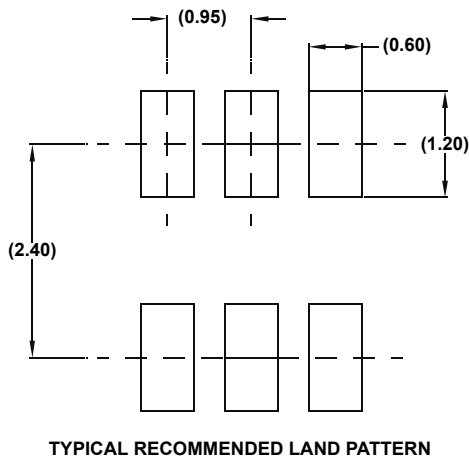
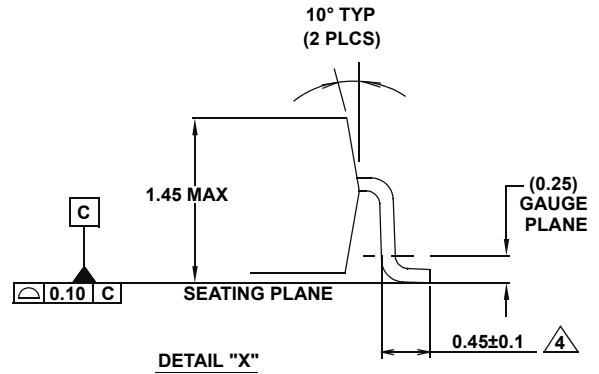
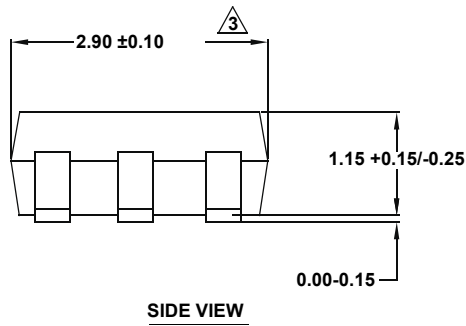
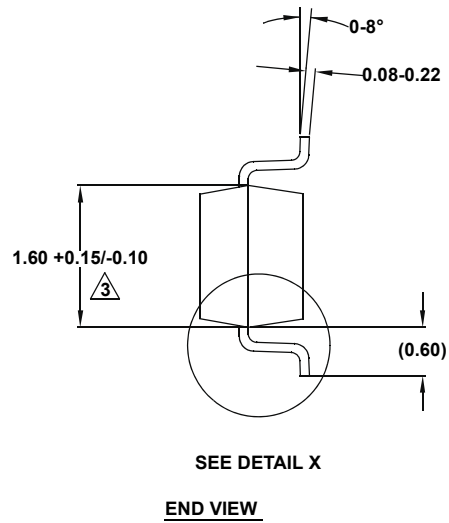
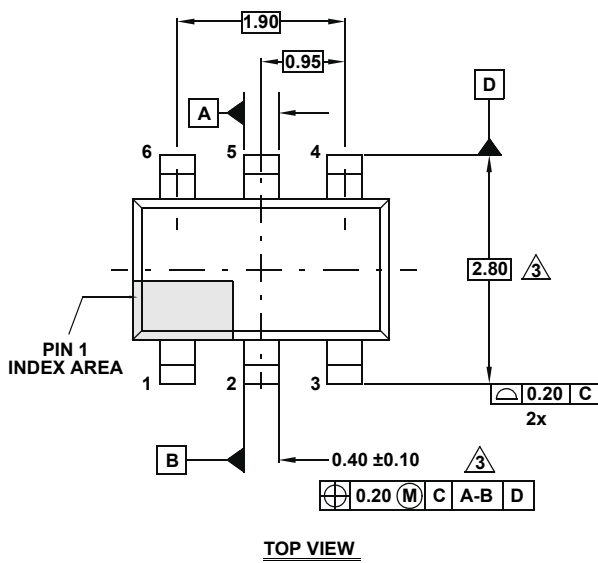

NOTES:

1. Dimensions are in millimeters.
Dimensions in () for Reference Only.
2. Dimensioning and tolerancing conform to ASME Y14.5M-1994.
3. Dimension is exclusive of mold flash, protrusions or gate burrs.
4. Foot length is measured at reference to gauge plane.
5. Package conforms to JEDEC MO-178AB.

Small Outline Transistor Plastic Packages (SC70-6)

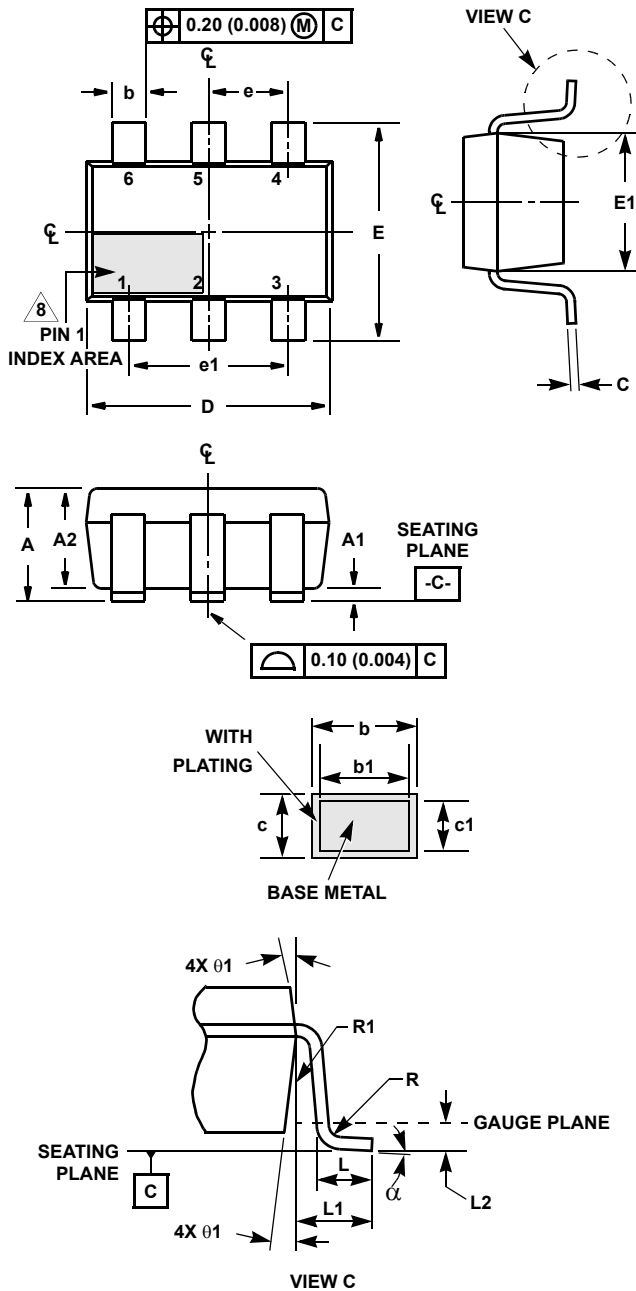

P6.049

6 LEAD SMALL OUTLINE TRANSISTOR PLASTIC PACKAGE

SYMBOL	INCHES		MILLIMETERS		NOTES
	MIN	MAX	MIN	MAX	
A	0.031	0.043	0.80	1.10	-
A1	0.000	0.004	0.00	0.10	-
A2	0.031	0.039	0.79	1.00	-
b	0.006	0.012	0.15	0.30	-
b1	0.006	0.010	0.15	0.25	
c	0.003	0.009	0.08	0.22	6
c1	0.003	0.009	0.08	0.20	6
D	0.073	0.085	1.85	2.15	3
E	0.071	0.094	1.80	2.40	-
E1	0.045	0.053	1.15	1.35	3
e	0.0256 Ref		0.65 Ref		-
e1	0.0512 Ref		1.30 Ref		-
L	0.010	0.018	0.26	0.46	4
L1	0.017 Ref.		0.420 Ref.		
L2	0.006 BSC		0.15 BSC		
N	6		6		5
R	0.004	-	0.10	-	
R1	0.004	0.010	0.15	0.25	
α	0°	8°	0°	8°	-

Rev. 4 12/12

NOTES:

1. Dimensioning and tolerance per ASME Y14.5M-1994.
2. Package conforms to EIAJ SC70 and JEDEC MO203AB.
3. Dimensions D and E1 are exclusive of mold flash, protrusions, or gate burrs.
4. Footlength L measured at reference to gauge plane.
5. "N" is the number of terminal positions.
6. These Dimensions apply to the flat section of the lead between 0.08mm and 0.15mm from the lead tip.
7. Controlling dimension: MILLIMETER. Converted inch dimensions are for reference only.
8. The configuration of the pin #1 identifier is optional, but must be located within the zone indicated. The pin #1 identifier may be either a mold or mark feature.

© Copyright Intersil Americas LLC 2005-2015. All Rights Reserved.
 All trademarks and registered trademarks are the property of their respective owners.

For additional products, see www.intersil.com/en/products.html

Intersil products are manufactured, assembled and tested utilizing ISO9001 quality systems as noted in the quality certifications found at www.intersil.com/en/support/qualandreliability.html

Intersil products are sold by description only. Intersil may modify the circuit design and/or specifications of products at any time without notice, provided that such modification does not, in Intersil's sole judgment, affect the form, fit or function of the product. Accordingly, the reader is cautioned to verify that datasheets are current before placing orders. Information furnished by Intersil is believed to be accurate and reliable. However, no responsibility is assumed by Intersil or its subsidiaries for its use; nor for any infringements of patents or other rights of third parties which may result from its use. No license is granted by implication or otherwise under any patent or patent rights of Intersil or its subsidiaries.

For information regarding Intersil Corporation and its products, see www.intersil.com

Looking for pricing, stock, or lifecycle information?

Click below to explore more details on WIN SOURCE:

 [View ISL90462UIH627Z-TK on WIN SOURCE](#)

 [Intersil Information](#)

Optimize Your Supply Chain with WIN SOURCE Solutions

-  Global Sourcing Solution
-  Obsolete Management
-  Cost Control Management
-  Shortage Management
-  Alternative Solution
-  Excess Inventory Management