



**THE DATASHEET OF  
ISL84716IH-T**



## ISL84715, ISL84716

Ultra Low ON-Resistance, Low Voltage, Single Supply, SPST Analog Switches

FN6087  
Rev 4.00  
August 18, 2015

The Intersil ISL84715 and ISL84716 devices are low ON-resistance, low voltage, bidirectional, single pole/single throw (SPST) analog switches designed to operate from a single +1.65V to +3.6V supply. Targeted applications include battery powered equipment that benefit from low  $R_{ON}$  resistance, excellent  $R_{ON}$  flatness, and fast switching speeds ( $t_{ON} = 9ns$ ,  $t_{OFF} = 5ns$ ). The digital logic input is 1.8V CMOS compatible when using a single +3V supply.

Cell phones, for example, often face ASIC functionality limitations. The number of analog input or GPIO pins may be limited and digital geometries are not well suited to analog switch performance. This family of parts may be used to switch in additional functionality while reducing ASIC design risk. The ISL8471X are offered in a 5 lead SC70 package, alleviating board space limitations.

The ISL84715 has one normally open (NO) switch and ISL84716 has one normally closed (NC) switch.

**TABLE 1. FEATURES AT A GLANCE**

	ISL84715	ISL84716
<b>Number of Switches</b>	1	1
<b>SW</b>	NO	NC
<b>1.8V <math>R_{ON}</math></b>	0.45 $\Omega$	0.45 $\Omega$
<b>1.8V <math>t_{ON}/t_{OFF}</math></b>	17ns/7ns	17ns/7ns
<b>3V <math>R_{ON}</math></b>	0.24 $\Omega$	0.24 $\Omega$
<b>3V <math>t_{ON}/t_{OFF}</math></b>	8ns/4ns	8ns/4ns
<b>Package</b>	5 Ld SC70	

## Features

- Pb-Free (RoHS Compliant)
- Drop in replacement for the MAX4715 and MAX4716
- ON resistance ( $R_{ON}$ )
  - $V_{CC} = +2.7V$  ..... 0.26 $\Omega$
  - $V_{CC} = +1.8V$  ..... 0.45 $\Omega$
- $R_{ON}$  flatness (+2.7V Supply) ..... 0.038 $\Omega$
- Single supply operation ..... +1.65V to +3.6V
- Fast switching action (+2.7V Supply)
  - $t_{ON}$  ..... 9ns
  - $t_{OFF}$  ..... 5ns
- ESD HBM rating ..... >4kV
- 1.8V, CMOS logic compatible (+3V supply)
- Available in 5 lead SC70 packaging

## Applications

- Battery powered, handheld, and portable equipment
  - Cellular/mobile phones
  - Pagers
  - Laptops, notebooks, palmtops
- Portable Test and Measurement
- Medical Equipment
- Audio and video switching

## Related Literature

- Technical Brief [TB363](#) "Guidelines for Handling and Processing Moisture Sensitive Surface Mount Devices (SMDs)"

## Pin Configurations (Note 1)

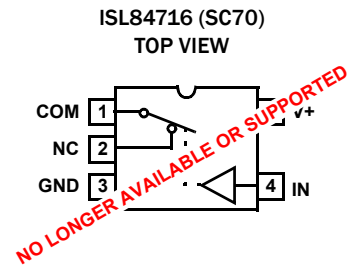
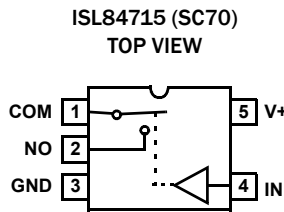

**NOTE:**

1. Switches Shown for Logic “0” Input.

## Truth Table

LOGIC	ISL84715	ISL84716
0	Off	On
1	On	Off

NOTE: Logic “0” ≤0.5V. Logic “1” ≥1.4V with a 3V supply.

## Pin Descriptions

PIN	FUNCTION
V+	System Power Supply Input (+1.65V to +3.6V)
GND	Ground Connection
IN	Digital Control Input
COM	Analog Switch Common Pin
NO	Analog Switch Normally Open Pin
NC	Analog Switch Normally Closed Pin

## Ordering Information

PART NUMBER (Notes 2, 3, 4)	PART MARKING (Note 5)	TEMP. RANGE (°C)	PACKAGE (RoHS Compliant)	PKG. DWG. #
ISL84715IHZ-T	CEA	-40 to +85	5 Ld SC70	P5.049
ISL84716IHZ-T (No longer available, recommended replacement: ISL84714IHZ-T)	CFA	-40 to +85	5 Ld SC70	P5.049

**NOTES:**

2. Please refer to [TB347](#) for details on reel specifications.
3. Intersil Pb-free products employ special Pb-free material sets; molding compounds/die attach materials and 100% matte tin plate termination finish, which are RoHS compliant and compatible with both SnPb and Pb-free soldering operations. Intersil Pb-free products are MSL classified at Pb-free peak reflow temperatures that meet or exceed the Pb-free requirements of IPC/JEDEC J STD-020C.
4. For Moisture Sensitivity Level (MSL), please see device information page for [ISL84715](#), [ISL84716](#). For more information on MSL please see tech brief [TB363](#).
5. The part marking is located on the bottom of the part.

## Absolute Maximum Ratings

V+ to GND	-0.3 to 4.8V
Input Voltages	
NO, NC, IN (Note 6)	-0.3 to ((V+) + 0.3V)
Output Voltages	
COM (Note 6)	-0.3 to ((V+) + 0.3V)
Continuous Current NO, NC, or COM	±300mA
Peak Current NO, NC, or COM (Pulsed 1ms, 10% Duty Cycle, Max)	±600mA
ESD Rating:	
Human Body Model	>4kV
Machine Model	>300V
Charged Device Model	>1000V

## Thermal Information

Thermal Resistance (Typical)	$\theta_{JA}$ (°C/W)
5 Ld SC70 Package (Note 7)	660
Maximum Junction Temperature (Plastic Package)	+150°C
Maximum Storage Temperature Range	-65°C to +150°C
Pb-Free Reflow Profile	see link below <a href="http://www.intersil.com/pbfree/Pb-FreeReflow.asp">http://www.intersil.com/pbfree/Pb-FreeReflow.asp</a>

## Operating Conditions

Temperature Range	
ISL8471XIHZ	-40°C to +85°C

**CAUTION:** Do not operate at or near the maximum ratings listed for extended periods of time. Exposure to such conditions may adversely impact product reliability and result in failures not covered by warranty

### NOTES:

- Signals on NC, NO, IN, or COM exceeding V+ or GND are clamped by internal diodes. Limit forward diode current to maximum current ratings.
- $\theta_{JA}$  is measured with the component mounted on a high effective thermal conductivity test board in free air. See Tech Brief [TB379](#) for details.

**Electrical Specifications - 3V Supply** Test Conditions: V+ = +2.7V to +3.6V, GND = 0V,  $V_{INH} = 1.4V$ ,  $V_{INL} = 0.5V$  (Notes 8, 10), unless otherwise specified. **Boldface limits apply over the operating temperature range, -40°C to +85°C.**

PARAMETER	TEST CONDITIONS	TEMP (°C)	MIN (Notes 9, 10)	TYP	MAX (Notes 9, 10)	UNITS
<b>ANALOG SWITCH CHARACTERISTICS</b>						
Analog Signal Range, $V_{ANALOG}$		Full	<b>0</b>	-	<b>V+</b>	V
ON Resistance, $R_{ON}$	V+ = 2.7V, $I_{COM} = 100mA$ , $V_{NO}$ or $V_{NC} = 1.5V$ (See Figure 4)	25	-	0.26	<b>0.4</b>	$\Omega$
		Full	-	-	<b>0.45</b>	$\Omega$
$R_{ON}$ Flatness, $R_{FLAT(ON)}$	V+ = 2.7V, $I_{COM} = 100mA$ , $V_{NO}$ or $V_{NC} = 0.6V, 1.5V, 2.1V$ (Note 11)	25	-	0.038	0.07	$\Omega$
		Full	-	-	<b>0.09</b>	$\Omega$
NO or NC OFF Leakage Current, $I_{NO(OFF)}$ or $I_{NC(OFF)}$	V+ = 3.3V, $V_{COM} = 0.3V, 3V$ , $V_{NO}$ or $V_{NC} = 3V, 0.3V$	25	-3	-	3	nA
		Full	<b>-20</b>	-	<b>20</b>	nA
COM OFF Leakage Current, $I_{COM(OFF)}$	V+ = 3.3V, $V_{COM} = 0.3V, 3V$ , $V_{NO}$ or $V_{NC} = 3V, 0.3V$	25	-3	-	3	nA
		Full	<b>-20</b>	-	<b>20</b>	nA
COM ON Leakage Current, $I_{COM(ON)}$	V+ = 3.3V, $V_{COM} = 0.3V, 3V$ , or $V_{NO}$ or $V_{NC} = 0.3V, 3V$ , or Floating	25	-3	-	3	nA
		Full	<b>-35</b>	-	<b>35</b>	nA
<b>DYNAMIC CHARACTERISTICS</b>						
Turn-ON Time, $t_{ON}$	V+ = 2.7V, $V_{NO}$ or $V_{NC} = 1.5V$ , $R_L = 50\Omega$ , $C_L = 35pF$ (See Figure 1)	25	-	9	<b>12</b>	ns
		Full	-	-	<b>15</b>	ns
Turn-OFF Time, $t_{OFF}$	V+ = 2.7V, $V_{NO}$ or $V_{NC} = 1.5V$ , $R_L = 50\Omega$ , $C_L = 35pF$ (See Figure 1)	25	-	5	<b>8</b>	ns
		Full	-	-	<b>11</b>	ns
Charge Injection, Q	$V_G = V+/2$ , $R_G = 0\Omega$ , $C_L = 1.0nF$ (See Figure 2)	25	-	70	-	pC
OFF Isolation	$R_L = 50\Omega$ , $C_L = 5pF$ , $f = 1MHz$ , $V_{COM} = 1V_{RMS}$ (See Figure 3)	25	-	-45	-	dB
Total Harmonic Distortion	$f = 20Hz$ to $20kHz$ , $V_{COM} = 2V_{P-P}$ , $R_L = 32\Omega$	25	-	0.003	-	%
NO or NC OFF Capacitance, $C_{OFF}$	$f = 1MHz$ , $V_{NO}$ or $V_{NC} = V_{COM} = 0V$ (See Figure 5)	25	-	68	-	pF
COM OFF Capacitance, $C_{COM(OFF)}$	$f = 1MHz$ , $V_{NO}$ or $V_{NC} = V_{COM} = 0V$ (See Figure 5)	25	-	68	-	pF
COM ON Capacitance, $C_{COM(ON)}$	$f = 1MHz$ , $V_{NO}$ or $V_{NC} = V_{COM} = 0V$ (See Figure 5)	25	-	160	-	pF

**Electrical Specifications - 3V Supply** Test Conditions:  $V_+ = +2.7V$  to  $+3.6V$ ,  $GND = 0V$ ,  $V_{INH} = 1.4V$ ,  $V_{INL} = 0.5V$  (Notes 8, 10), unless otherwise specified. **Boldface limits apply over the operating temperature range,  $-40^\circ C$  to  $+85^\circ C$ .** (Continued)

PARAMETER	TEST CONDITIONS	TEMP ( $^\circ C$ )	MIN (Notes 9, 10)	TYP	MAX (Notes 9, 10)	UNITS
<b>POWER SUPPLY CHARACTERISTICS</b>						
Power Supply Range		Full	<b>1.65</b>	-	<b>3.6</b>	V
Positive Supply Current, $I_+$	$V_+ = 3.6V$ , $V_{IN} = 0V$ or $V_+$	25	-	0.018	0.05	$\mu A$
		Full	-	-	<b>0.35</b>	$\mu A$
<b>DIGITAL INPUT CHARACTERISTICS</b>						
Input Voltage Low, $V_{INL}$		Full	-	-	<b>0.5</b>	V
Input Voltage High, $V_{INH}$		Full	<b>1.4</b>	-	-	V
Input Current, $I_{INH}$ , $I_{INL}$	$V_+ = 3.6V$ , $V_{IN} = 0V$ or $V_+$	Full	<b>-1</b>	-	<b>1</b>	$\mu A$

## NOTES:

8.  $V_{IN}$  = input voltage to perform proper function.
9. The algebraic convention, whereby the most negative value is a minimum and the most positive a maximum, is used in this data sheet.
10. Compliance to datasheet limits is assured by one or more methods: production test, characterization and/or design.
11. Flatness is defined as the difference between maximum and minimum value of on-resistance over the specified analog signal range.

**Electrical Specifications - 1.8V Supply** Test Conditions:  $V_+ = +1.8V$ ,  $GND = 0V$ ,  $V_{INH} = 1V$ ,  $V_{INL} = 0.4V$  (Notes 4, 6), unless otherwise specified. **Boldface limits apply over the operating temperature range,  $-40^\circ C$  to  $+85^\circ C$ .**

PARAMETER	TEST CONDITIONS	TEMP ( $^\circ C$ )	MIN (Notes 9, 10)	TYP	MAX (Notes 9, 10)	UNITS
<b>ANALOG SWITCH CHARACTERISTICS</b>						
Analog Signal Range, $V_{ANALOG}$		Full	<b>0</b>	-	<b><math>V_+</math></b>	V
ON Resistance, $R_{ON}$	$V_+ = 1.8V$ , $I_{COM} = 10mA$ , $V_{NO}$ or $V_{NC} = 0.9V$ (See Figure 4)	25	-	0.45	0.6	$\Omega$
		Full	-	-	<b>0.8</b>	$\Omega$
NO or NC OFF Leakage Current, $I_{NO(OFF)}$ or $I_{NC(OFF)}$	$V_+ = 1.8V$ , $V_{COM} = 0.3V$ , $1.5V$ , $V_{NO}$ or $V_{NC} = 1.5V$ , $0.3V$	25	-2	-	2	nA
		Full	<b>-20</b>	-	<b>20</b>	nA
COM OFF Leakage Current, $I_{COM(OFF)}$	$V_+ = 1.8V$ , $V_{COM} = 0.3V$ , $1.5V$ , $V_{NO}$ or $V_{NC} = 1.5V$ , $0.3V$	25	-2	-	2	nA
		Full	<b>-20</b>	-	<b>20</b>	nA
COM ON Leakage Current, $I_{COM(ON)}$	$V_+ = 1.8V$ , $V_{COM} = 0.3V$ , $1.5V$ , or $V_{NO}$ or $V_{NC} = 0.3V$ , $1.5V$ , or Floating	25	-1	-	1	nA
		Full	<b>-20</b>	-	<b>20</b>	nA
<b>DYNAMIC CHARACTERISTICS</b>						
Turn-ON Time, $t_{ON}$	$V_+ = 1.8V$ , $V_{NO}$ or $V_{NC} = 1.5V$ , $R_L = 50\Omega$ , $C_L = 35pF$ (See Figure 1)	25	-	17	22	ns
		Full	-	-	<b>24</b>	ns
Turn-OFF Time, $t_{OFF}$	$V_+ = 1.8V$ , $V_{NO}$ or $V_{NC} = 1.5V$ , $R_L = 50\Omega$ , $C_L = 35pF$ (See Figure 1)	25	-	7	11	ns
		Full	-	-	<b>14</b>	ns
Charge Injection, Q	$V_G = V_+/2$ , $R_G = 0\Omega$ , $C_L = 1.0nF$ (See Figure 2)	25	-	60	-	pC
<b>POWER SUPPLY CHARACTERISTICS</b>						
Positive Supply Current, $I_+$	$V_{IN} = 0V$ or $V_+$	25	-	0.018	0.05	$\mu A$
		Full	-	-	<b>0.35</b>	$\mu A$
<b>DIGITAL INPUT CHARACTERISTICS</b>						
Input Voltage Low, $V_{INL}$		Full	-	-	<b>0.4</b>	V
Input Voltage High, $V_{INH}$		Full	<b>1</b>	-	-	V
Input Current, $I_{INH}$ , $I_{INL}$	$V_{IN} = 0V$ or $V_+$	Full	<b>-1</b>	-	<b>1</b>	$\mu A$

## Test Circuits and Waveforms

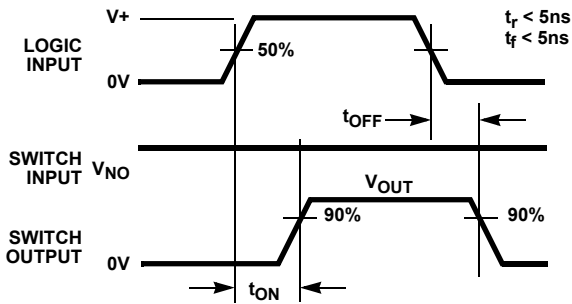

Logic input waveform is inverted for switches that have the opposite logic sense.

FIGURE 1A. MEASUREMENT POINTS

FIGURE 1. SWITCHING TIMES

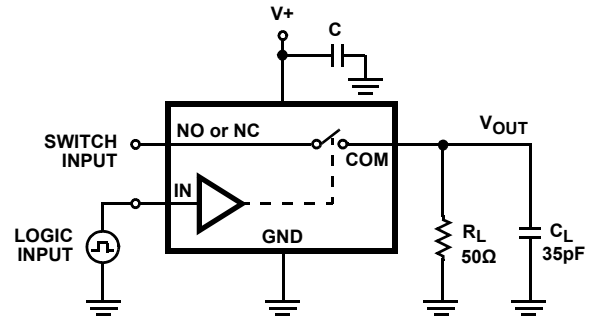

Repeat test for all switches.  $C_L$  includes fixture and stray capacitance.

$$V_{OUT} = V_{(NO \text{ or } NC)} \frac{R_L}{R_L + R_{(ON)}}$$

FIGURE 1B. TEST CIRCUIT

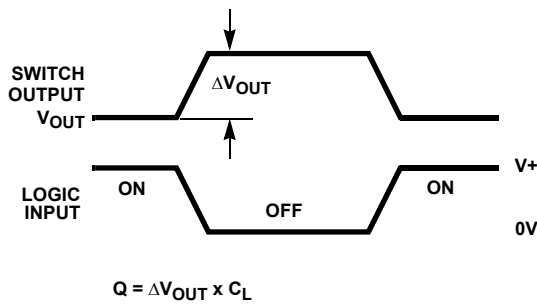

FIGURE 2A. MEASUREMENT POINTS

FIGURE 2. CHARGE INJECTION

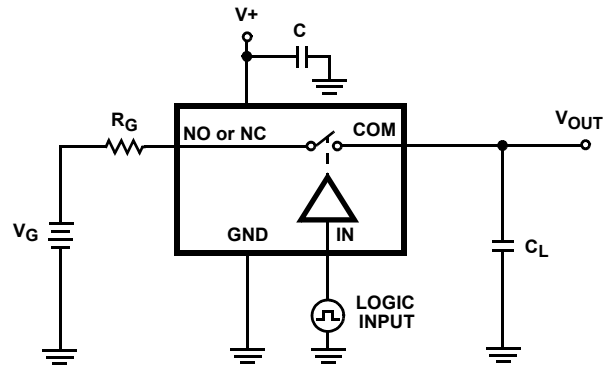

FIGURE 2B. TEST CIRCUIT

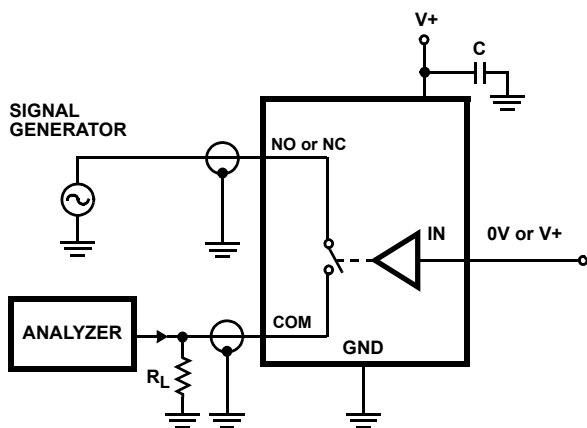

FIGURE 3. OFF ISOLATION TEST CIRCUIT

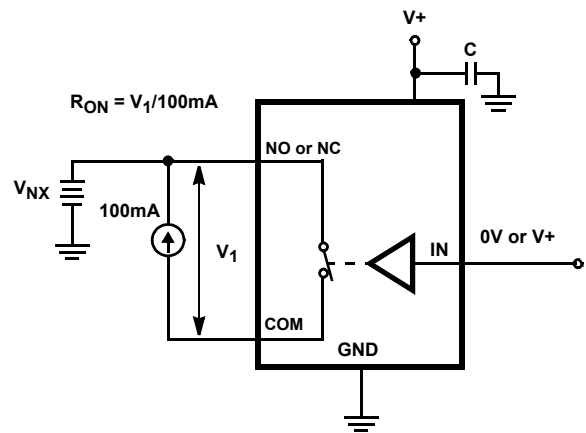

FIGURE 4. RON TEST CIRCUIT

## Test Circuits and Waveforms (Continued)

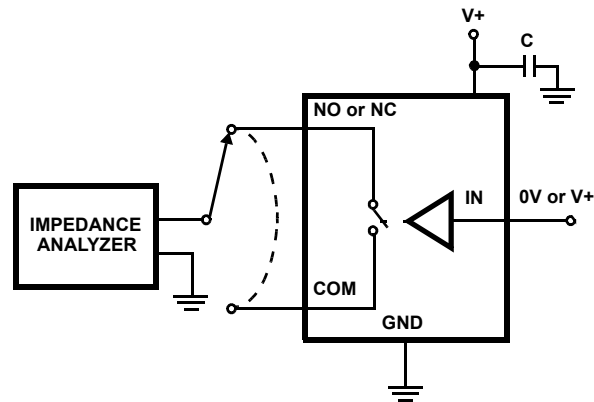

FIGURE 5. CAPACITANCE TEST CIRCUIT

## Detailed Description

The ISL84715 and ISL84716 are bidirectional, single pole/single throw (SPST) analog switches. They offer precise switching capability from a single 1.65V to 3.6V supply with ultra low on-resistance and high speed operation. With a single supply of 3V the typical on-resistance is only  $0.26\Omega$ , with a typical turn-on and turn-off time of:  $t_{ON} = 9\text{ns}$ ,  $t_{OFF} = 5\text{ns}$ . The devices are especially well suited for portable battery powered equipment due to its low operating supply voltage (1.65V), low power consumption ( $1.05\mu\text{W}$ ), low leakage currents (35nA max), and the tiny SC70 packaging.

The ISL84715 is a normally open (NO) SPST analog switch. The ISL84716 is a normally closed (NC) SPST analog switch.

## Supply Sequencing and Overvoltage Protection

With any CMOS device, proper power supply sequencing is required to protect the device from excessive input currents which might permanently damage the IC. All I/O pins contain ESD protection diodes from the pin to V+ and to GND (see Figure 6). To prevent forward biasing these diodes, V+ must be applied before any input signals, and the input signal voltages must remain between V+ and GND.

If these conditions cannot be guaranteed, then precautions must be implemented to prohibit the current and voltage at the logic pin and signal pins from exceeding the maximum ratings of the switch. The following two methods can be used to provide additional protection to limit the current in the event that the voltage at a signal pin or logic pin goes below ground or above the V+ rail.

Logic inputs can be protected by adding a  $1\text{k}\Omega$  resistor in series with the logic input (see Figure 6). The resistor limits the input current below the threshold that produces permanent damage, and the sub-microamp input current produces an insignificant voltage drop during normal operation.

This method is not acceptable for the signal path inputs. Adding a series resistor to the switch input defeats the purpose of using a low  $r_{ON}$  switch. Connecting Schottky diodes to the signal pins (as shown in Figure 6) will shunt the fault current to the supply or

to ground thereby protecting the switch. These Schottky diodes must be sized to handle the expected fault current.

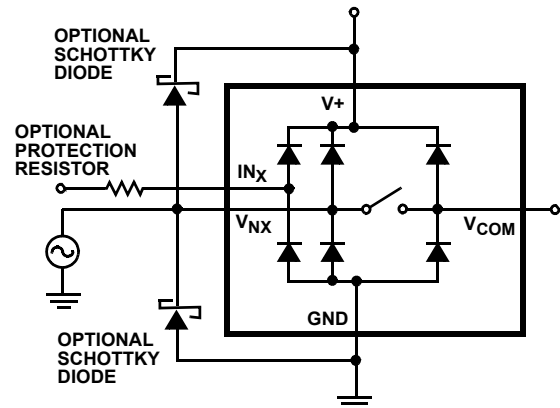

FIGURE 6. OVERVOLTAGE PROTECTION

## Power-Supply Considerations

The ISL8471X construction is typical of most single supply CMOS analog switches in that they have two supply pins: V+ and GND. V+ and GND drive the internal CMOS switches and set their analog voltage limits. Unlike switches with a 4V maximum supply voltage, the ISL84714 4.8V maximum supply voltage provides plenty of room for the 10% tolerance of 3.6V supplies, as well as room for overshoot and noise spikes.

The minimum recommended supply voltage is 3.6V but the part will operate with a supply below 1.5V. It is important to note that the input signal range, switching times, and on-resistance degrade at lower supply voltages. Refer to the electrical specification tables and *Typical Performance* curves for details.

V+ and GND also power the internal logic and level shifter. The level shifter converts the input logic levels to switched V+ and GND signals to drive the analog switch gate terminals.

This family of switches cannot be operated with bipolar supplies, because the input switching point becomes negative in this configuration.

### Logic-Level Thresholds

This switch family is 1.8V CMOS compatible (0.5V and 1.4V) over a supply range of 2V to 3.6V (see Figure 13). At 3.6V the  $V_{IH}$  level is about 1.1V. This is still below the 1.8V CMOS guaranteed high output minimum level of 1.4V, but noise margin is reduced.

The digital input stages draw supply current whenever the digital input voltage is not at one of the supply rails. Driving the digital input signals from GND to V+ with a fast transition time minimizes power dissipation.

### High-Frequency Performance

In 50Ω systems, signal response is reasonably flat even past 100MHz (See Figure 14). The frequency response is very consistent over a wide V+ range, and for varying analog signal levels.

An OFF switch acts like a capacitor and passes higher frequencies with less attenuation, resulting in signal feedthrough from a switch’s input to its output. Off Isolation is the resistance to this feedthrough. Figure 15 details the high Off Isolation rejection provided by this family. At 1MHz, Off Isolation is about 45dB in 50Ω systems, decreasing

approximately 20dB per decade as frequency increases. Higher load impedances decrease Off Isolation and Crosstalk rejection due to the voltage divider action of the switch OFF impedance and the load impedance.

### Leakage Considerations

Reverse ESD protection diodes are internally connected between each analog-signal pin and both V+ and GND. One of these diodes conducts if any analog signal exceeds V+ or GND.

Virtually all the analog leakage current comes from the ESD diodes to V+ or GND. Although the ESD diodes on a given signal pin are identical and therefore fairly well balanced, they are reverse biased differently. Each is biased by either V+ or GND and the analog signal. This means their leakages will vary as the signal varies. The difference in the two diode leakages to the V+ and GND pins constitutes the analog-signal-path leakage current. All analog leakage current flows between each pin and one of the supply terminals, not to the other switch terminal. This is why both sides of a given switch can show leakage currents of the same or opposite polarity. There is no connection between the analog signal paths and V+ or GND.

### Typical Performance Curves $T_A = +25^\circ\text{C}$ , unless otherwise specified

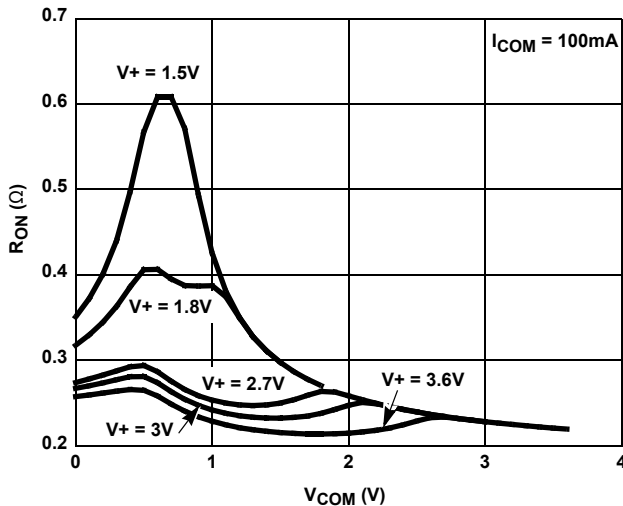

FIGURE 7. ON RESISTANCE vs SUPPLY VOLTAGE vs SWITCH VOLTAGE

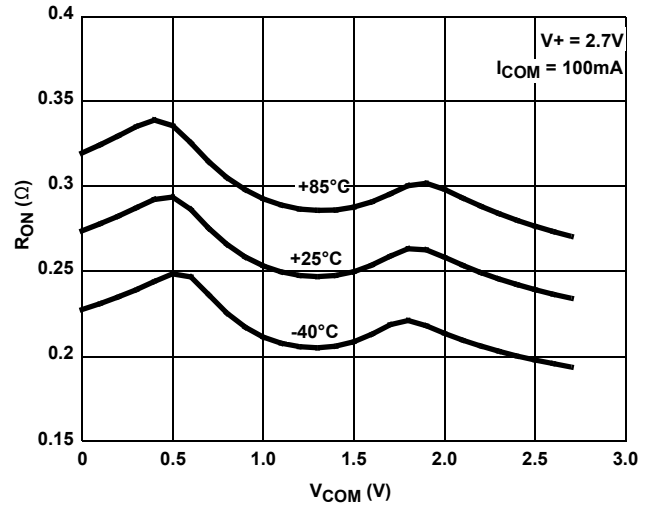

FIGURE 8. ON RESISTANCE vs SWITCH VOLTAGE

**Typical Performance Curves**  $T_A = +25^\circ\text{C}$ , unless otherwise specified **(Continued)**

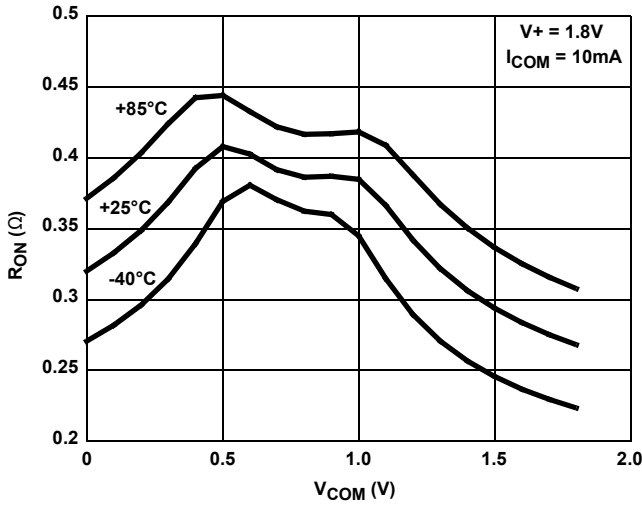

FIGURE 9. ON RESISTANCE vs SWITCH VOLTAGE

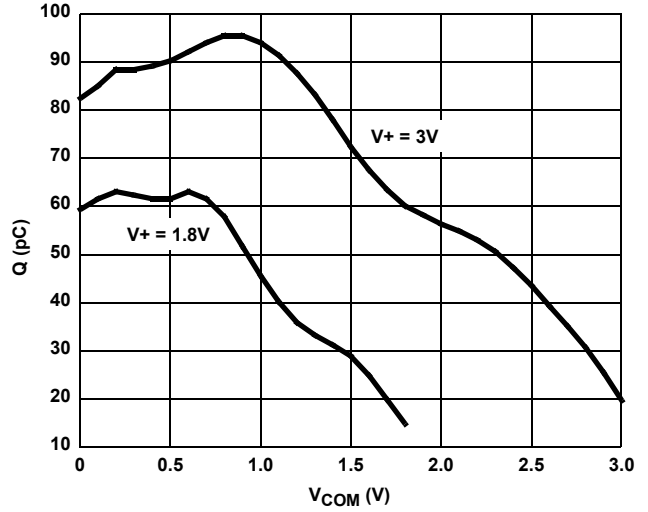

FIGURE 10. CHARGE INJECTION vs SWITCH VOLTAGE

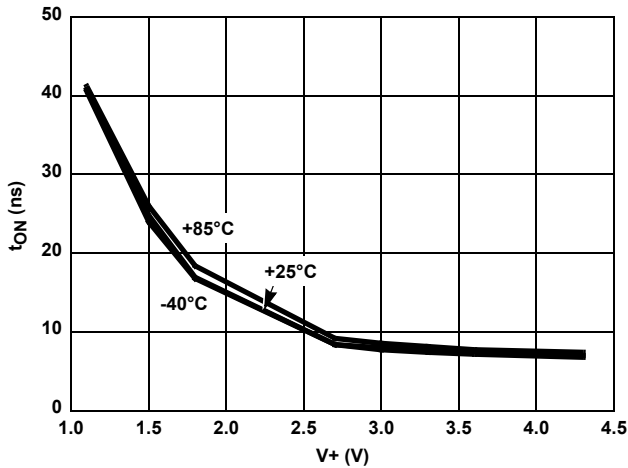

FIGURE 11. TURN - ON TIME vs SUPPLY VOLTAGE

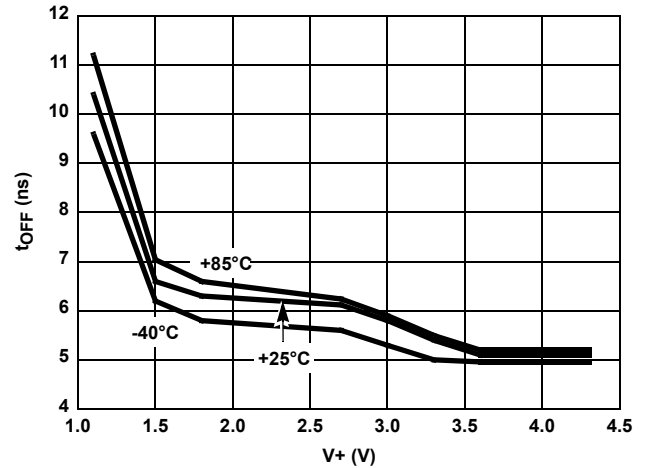

FIGURE 12. TURN - OFF TIME vs SUPPLY VOLTAGE

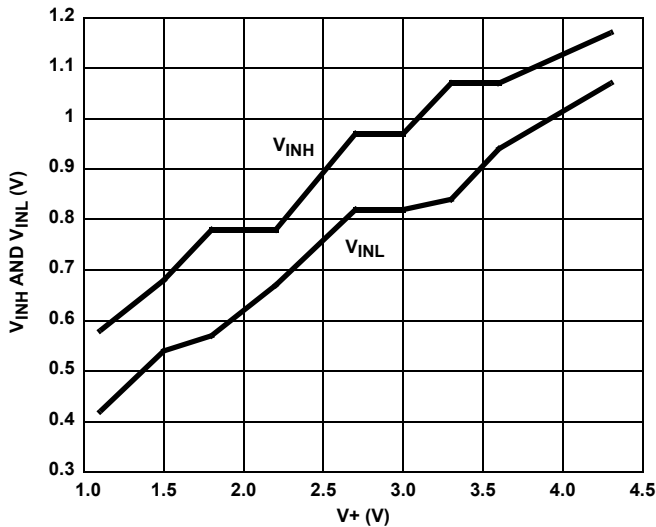

FIGURE 13. DIGITAL SWITCHING POINT vs SUPPLY VOLTAGE

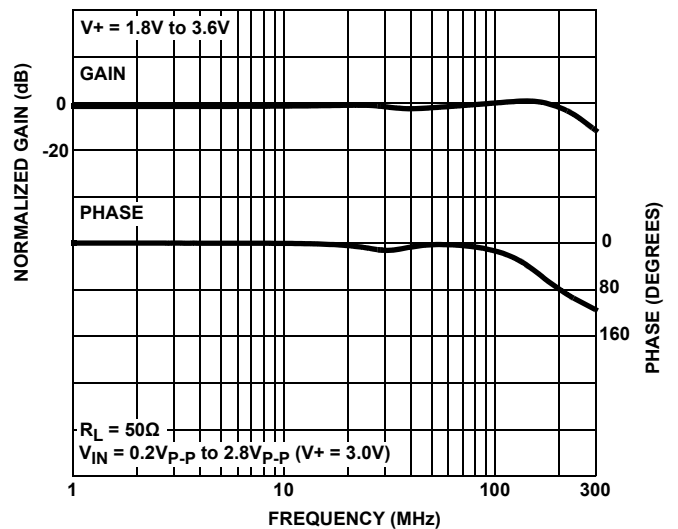
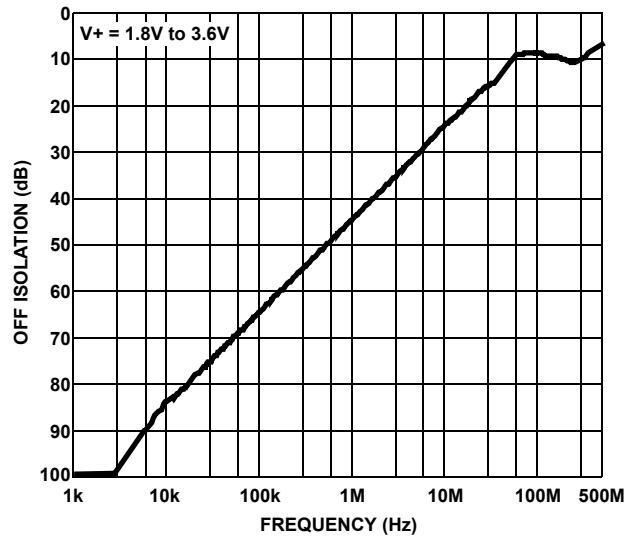

FIGURE 14. FREQUENCY RESPONSE

**Typical Performance Curves**  $T_A = +25^\circ\text{C}$ , unless otherwise specified **(Continued)**



**FIGURE 15. OFF ISOLATION**

**Die Characteristics**

**SUBSTRATE POTENTIAL (POWERED UP):**

GND

**TRANSISTOR COUNT: 57**

**PROCESS:**

Submicron CMOS

© Copyright Intersil Americas LLC 2004-2015. All Rights Reserved.  
 All trademarks and registered trademarks are the property of their respective owners.

For additional products, see [www.intersil.com/en/products.html](http://www.intersil.com/en/products.html)

Intersil products are manufactured, assembled and tested utilizing ISO9001 quality systems as noted in the quality certifications found at [www.intersil.com/en/support/qualandreliability.html](http://www.intersil.com/en/support/qualandreliability.html)

*Intersil products are sold by description only. Intersil may modify the circuit design and/or specifications of products at any time without notice, provided that such modification does not, in Intersil's sole judgment, affect the form, fit or function of the product. Accordingly, the reader is cautioned to verify that datasheets are current before placing orders. Information furnished by Intersil is believed to be accurate and reliable. However, no responsibility is assumed by Intersil or its subsidiaries for its use; nor for any infringements of patents or other rights of third parties which may result from its use. No license is granted by implication or otherwise under any patent or patent rights of Intersil or its subsidiaries.*

For information regarding Intersil Corporation and its products, see [www.intersil.com](http://www.intersil.com)

---

## Revision History

The revision history provided is for informational purposes only and is believed to be accurate, but not warranted. Please go to the web to make sure that you have the latest revision.

DATE	REVISION	CHANGE
August 18, 2015	FN6087.4	Updated the Ordering Information table on page 2. Added Revision History and About Intersil sections.

---

## About Intersil

Intersil Corporation is a leading provider of innovative power management and precision analog solutions. The company's products address some of the largest markets within the industrial and infrastructure, mobile computing and high-end consumer markets.

For the most updated datasheet, application notes, related documentation and related parts, please see the respective product information page found at [www.intersil.com](http://www.intersil.com).

You may report errors or suggestions for improving this datasheet by visiting [www.intersil.com/ask](http://www.intersil.com/ask).

Reliability reports are also available from our website at [www.intersil.com/support](http://www.intersil.com/support)

**Small Outline Transistor Plastic Packages (SC70-5)**

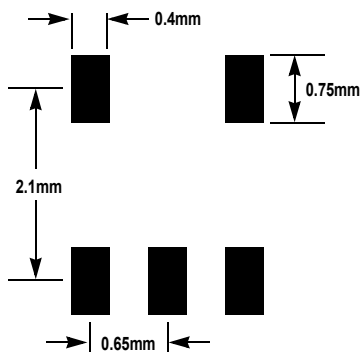
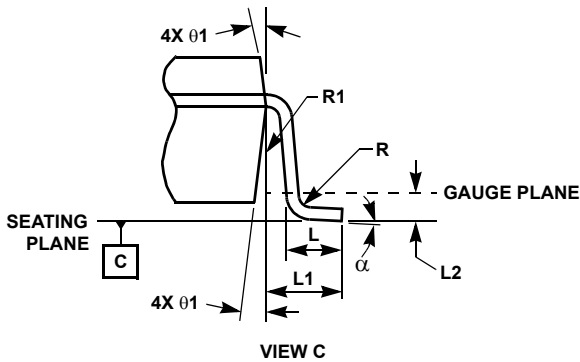
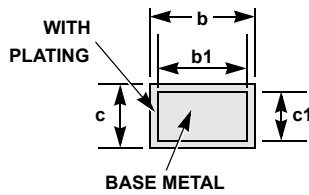
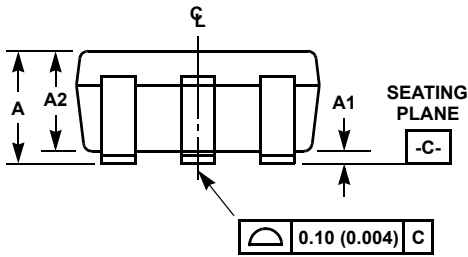
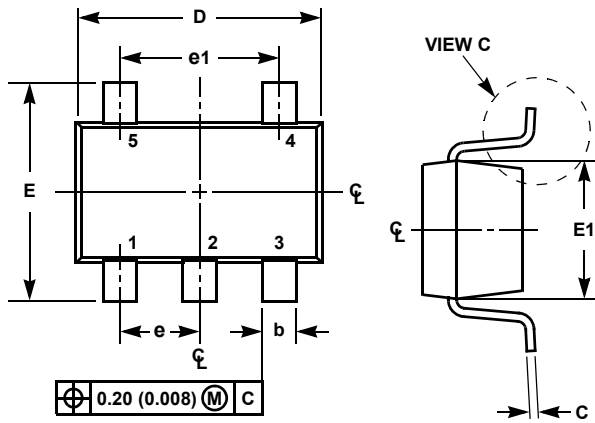

TYPICAL RECOMMENDED LAND PATTERN

**P5.049**

**5 LEAD SMALL OUTLINE TRANSISTOR PLASTIC PACKAGE**

SYMBOL	INCHES		MILLIMETERS		NOTES
	MIN	MAX	MIN	MAX	
A	0.031	0.043	0.80	1.10	-
A1	0.000	0.004	0.00	0.10	-
A2	0.031	0.039	0.80	1.00	-
b	0.006	0.012	0.15	0.30	-
b1	0.006	0.010	0.15	0.25	-
c	0.003	0.009	0.08	0.22	6
c1	0.003	0.009	0.08	0.20	6
D	0.073	0.085	1.85	2.15	3
E	0.071	0.094	1.80	2.40	-
E1	0.045	0.053	1.15	1.35	3
e	0.0256 Ref		0.65 Ref		-
e1	0.0512 Ref		1.30 Ref		-
L	0.010	0.018	0.26	0.46	4
L1	0.017 Ref.		0.420 Ref.		-
L2	0.006 BSC		0.15 BSC		-
α	0°	8°	0°	8°	-
N	5		5		5
R	0.004	-	0.10	-	-
R1	0.004	0.010	0.15	0.25	-

Rev. 3 7/07

**NOTES:**

1. Dimensioning and tolerances per ASME Y14.5M-1994.
2. Package conforms to EIAJ SC70 and JEDEC MO-203AA.
3. Dimensions D and E1 are exclusive of mold flash, protrusions, or gate burrs.
4. Footlength L measured at reference to gauge plane.
5. "N" is the number of terminal positions.
6. These Dimensions apply to the flat section of the lead between 0.08mm and 0.15mm from the lead tip.
7. Controlling dimension: MILLIMETER. Converted inch dimensions are for reference only.

## Looking for pricing, stock, or lifecycle information?

Click below to explore more details on WIN SOURCE:

 [View ISL84716IH-T on WIN SOURCE](#)

 [Intersil Information](#)

## Optimize Your Supply Chain with WIN SOURCE Solutions

-  Global Sourcing Solution
-  Obsolete Management
-  Cost Control Management
-  Shortage Management
-  Alternative Solution
-  Excess Inventory Management