



**THE DATASHEET OF  
ISL83220ECVZ**



## ISL83220E

±15kV ESD Protected, +3V to +5.5V, 1µA, 250kbps, RS-232 Transmitters/Receivers

The [ISL83220E](#) is a 3.0V to 5.5V powered RS-232 transmitter/receiver that meets EIA/TIA-232 and V.28/V.24 specifications, even at  $V_{CC} = 3.0V$ . It provides ±15kV ESD protection (IEC61000-4-2 Air Gap and Human Body Model) on transmitter outputs and receiver inputs (RS-232 pins). Targeted applications are PDAs, Palmtops, and notebook and laptop computers in which the low operational power consumption and even lower standby power consumption is critical. Efficient on-chip charge pumps, coupled with a manual powerdown function, reduce the standby supply current to a 1µA trickle. Small footprint packaging and the use of small, low value capacitors ensure board space savings. Data rates greater than 250kbps are ensured at worst case load conditions. The ISL83220E is fully compatible with 3.3V only systems, mixed 3.3V and 5.0V systems, and 5.0V only systems.

[Table 1](#) summarizes the features of the ISL83220E, and [Application Note AN9863](#) summarizes the features of each device in the ICL32xxE 3V family.

### Related Literature

For a full list of related documents, visit our website:

- [ISL83220E](#) device page

### Features

- Pb-free (RoHS compliant)
- ESD protection for RS-232 I/O pins to ±15kV (IEC61000)
- Drop-in replacement for SP3220E
- Meets EIA/TIA-232 and V.28/V.24 specifications at 3V
- RS-232 compatible outputs at 2.7V
- Latch-up free
- On-chip voltage converters require only four external 0.1µF capacitors
- Manual powerdown feature with receivers active
- Separate receiver enable pin
- $R_X$  and  $T_X$  hysteresis for improved noise immunity
- Ensured minimum data rate: 250kbps
- Ensured minimum slew rate: 6V/µs
- Wide power supply range: Single +3V to +5.5V
- Low supply current in powerdown state: 1µA

### Applications

- Any system requiring RS-232 communication ports
  - Battery powered, hand-held, and portable equipment
  - Laptop computers, notebooks, and Palmtops
  - Modems, printers and other peripherals
  - Digital cameras
  - Cellular and mobile phones

**Table 1. Summary of Features**

Part Number	No. of Tx.	No. of Rx.	No. of Monitor Rx. ( $R_{OUTB}$ )	Data Rate (kbps)	Rx. Enable Function?	Ready Output?	Manual Power-Down?	Automatic Powerdown Function?
ISL83220E	1	1	0	250	Yes	No	Yes	No

# 1. Overview

## 1.1 Typical Operating Circuit

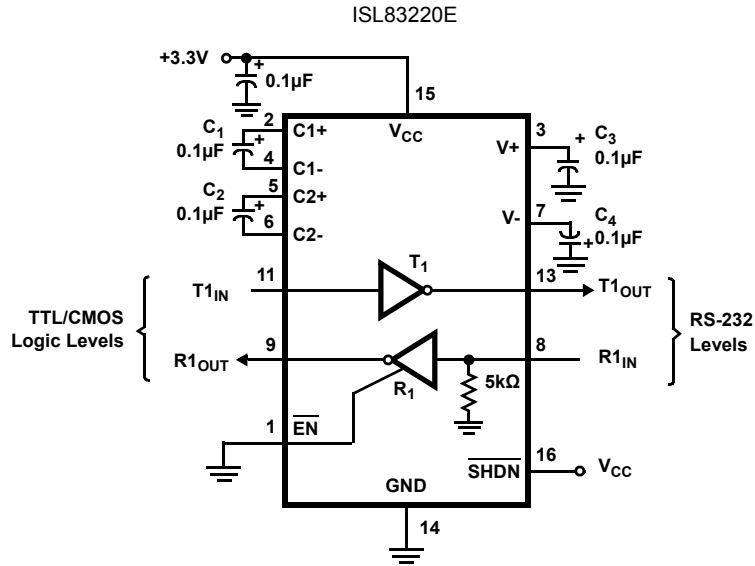

## 1.2 Ordering Information

Part Number (Notes 2, 3)	Part Marking	Temp. Range (°C)	Tape and Reel (Units) (Note 1)	Package (RoHS Compliant)	Pkg. Dwg. #
ISL83220ECVZ	83220ECVZ	0 to +70	-	16 Ld TSSOP	M16.173
ISL83220ECVZ-T	83220ECVZ	0 to +70	2.5k	16 Ld TSSOP	M16.173
ISL83220EIVZ	83220EIVZ	-40 to +85	-	16 Ld TSSOP	M16.173
ISL83220EIVZ-T	83220EIVZ	-40 to +85	2.5k	16 Ld TSSOP	M16.173

Notes:

1. See [TB347](#) for details about reel specifications.
2. These Pb-free plastic packaged products employ special Pb-free material sets, molding compounds/die attach materials, and 100% matte tin plate plus anneal (e3 termination finish, which is RoHS compliant and compatible with both SnPb and Pb-free soldering operations). Pb-free products are MSL classified at Pb-free peak reflow temperatures that meet or exceed the Pb-free requirements of IPC/JEDEC J-STD-020.
3. For Moisture Sensitivity Level (MSL), see the [ISL83220E](#) device page. For more information about MSL, see [TB363](#).

## 1.3 Pin Configuration

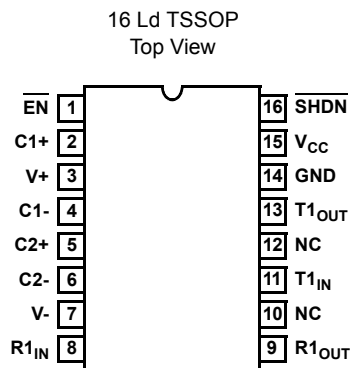

## 1.4 Pin Descriptions

Pin	Function
V <sub>CC</sub>	System power supply input (3.0V to 5.5V).
V+	Internally generated positive transmitter supply (+5.5V).
V-	Internally generated negative transmitter supply (-5.5V).
GND	Ground connection.
C1+	External capacitor (voltage doubler) is connected to this lead.
C1-	External capacitor (voltage doubler) is connected to this lead.
C2+	External capacitor (voltage inverter) is connected to this lead.
C2-	External capacitor (voltage inverter) is connected to this lead.
T1 <sub>IN</sub>	TTL/CMOS compatible transmitter inputs.
T1 <sub>OUT</sub>	±15kV ESD protected, RS-232 level (nominally ±5.5V) transmitter outputs.
R1 <sub>IN</sub>	±15kV ESD protected, RS-232 compatible receiver inputs.
R1 <sub>OUT</sub>	TTL/CMOS level receiver outputs.
$\overline{\text{EN}}$	Active low receiver enable control; does not disable R <sub>OUTB</sub> outputs.
$\overline{\text{SHDN}}$	Active low input that shuts down transmitters and on-board power supply to place the device in low power mode.
NC	No internal connection.

## 2. Specifications

### 2.1 Absolute Maximum Ratings

Parameter	Minimum	Maximum	Unit
V <sub>CC</sub> to GND	-0.3	6	V
V+ to GND	-0.3	7	V
V- to GND	+0.3	-7	V
V+ to V-		14	V
<b>Input Voltages</b>			
T <sub>IN</sub> , $\overline{\text{EN}}$ , $\overline{\text{SHDN}}$	-0.3	6	V
R <sub>IN</sub>		±25	V
<b>Output Voltages</b>			
T <sub>OUT</sub>		±13.2	V
R <sub>OUT</sub>	-0.3	V <sub>CC</sub> + 0.3	V
<b>Short-Circuit Duration</b>			
T <sub>OUT</sub>	Continuous		
<b>ESD Rating</b>	See <a href="#">ESD Performance</a>		

CAUTION: Do not operate at or near the maximum ratings listed for extended periods of time. Exposure to such conditions can adversely impact product reliability and result in failures not covered by warranty.

### 2.2 Thermal Information

Thermal Resistance (Typical) <a href="#">Note 4</a>	$\theta_{JA}$ (°C/W)
16 Ld TSSOP Package	145

Note:

- $\theta_{JA}$  is measured with the component mounted on a low-effective thermal conductivity test board in free air. See [TB379](#) for details.

Parameter	Minimum	Maximum	Unit
Maximum Junction Temperature (Plastic Package)		+150	°C
Maximum Storage Temperature Range	-65	+150	°C
Pb-Free Reflow Profile	see <a href="#">TB493</a>		

### 2.3 Recommended Operating Conditions

Parameter	Minimum	Maximum	Unit
Temperature Range	0°	+70	°C

### 2.4 Electrical Specifications

Test conditions: V<sub>CC</sub> = 3V to 5.5V, C<sub>1</sub> - C<sub>4</sub> = 0.1µF; unless otherwise specified. Typicals are at T<sub>A</sub> = 25°C

Parameter	Test Conditions	Temp (°C)	Min	Typ	Max	Unit
<b>DC Characteristics</b>						
Supply Current	All Outputs Unloaded, SHDN = V <sub>CC</sub>	V <sub>CC</sub> = 3.15V	25	-	0.3	1.0 mA
Supply Current, Powerdown	$\overline{\text{SHDN}}$ = GND		25	-	1.0	10 µA
<b>Logic and Transmitter Inputs and Receiver Outputs</b>						
Input Logic Threshold Low	T <sub>IN</sub> , $\overline{\text{EN}}$ , $\overline{\text{SHDN}}$	Full	-	-	0.8	V

Test conditions:  $V_{CC} = 3V$  to  $5.5V$ ,  $C_1 - C_4 = 0.1\mu F$ ; unless otherwise specified. Typicals are at  $T_A = 25^\circ C$  (Continued)

Parameter	Test Conditions	Temp ( $^\circ C$ )	Min	Typ	Max	Unit	
Input Logic Threshold High	$T_{IN}, \overline{EN}, \overline{SHDN}$	$V_{CC} = 3.3V$	Full	2.0	-	-	V
		$V_{CC} = 5.0V$	Full	2.4	-	-	V
Transmitter Input Hysteresis		25	-	0.3		V	
Input Leakage Current	$T_{IN}, \overline{EN}, \overline{SHDN}$	Full	-	$\pm 0.01$	$\pm 1.0$	$\mu A$	
Output Leakage Current	$\overline{EN} = V_{CC}$	Full	-	$\pm 0.05$	$\pm 10$	$\mu A$	
Output Voltage Low	$I_{OUT} = 1.6mA$	Full	-	-	0.4	V	
Output Voltage High	$I_{OUT} = -1.0mA$	Full	$V_{CC} - 0.6$	$V_{CC} - 0.1$	-	V	
<b>Transmitter Outputs</b>							
Output Voltage Swing	All Transmitter Outputs Loaded with $3k\Omega$ to Ground	Full	$\pm 5.0$	$\pm 5.4$	-	V	
Output Resistance	$V_{CC} = V_+ = V_- = 0V$ , Transmitter Output = $\pm 2V$	Full	300	10M	-	$\Omega$	
Output Short-Circuit Current	$V_{OUT} = 0V$	Full	-	$\pm 35$	$\pm 60$	mA	
Output Leakage Current	$V_{OUT} = \pm 12V$ , $V_{CC} = 0V$ or $3V$ to $5.5V$ , $\overline{SHDN} = GND$	Full	-	-	$\pm 25$	$\mu A$	
<b>Receiver Inputs</b>							
Input Voltage Range		Full	-25	-	25	V	
Input Threshold Low	$V_{CC} = 3.3V$	Full	0.6	1.2	-	V	
	$V_{CC} = 5.0V$	Full	0.8	1.5	-	V	
Input Threshold High	$V_{CC} = 3.3V$	Full	-	1.5	2.4	V	
	$V_{CC} = 5.0V$	Full	-	1.8	2.4	V	
Input Hysteresis		25	-	0.3	-	V	
Input Resistance		Full	3	5	7	$k\Omega$	
<b>Timing Characteristics</b>							
Maximum Data Rate	$R_L = 3k\Omega$ , $C_L = 1000pF$ , One Transmitter Switching	Full	250	500	-	kbps	
Transmitter Propagation Delay	Transmitter Input to Transmitter Output, $R_L = 3k\Omega$ , $C_L = 1000pF$	$t_{PHL}$	25	-	1.0	-	$\mu s$
		$t_{PLH}$	25	-	1.0	-	$\mu s$
Receiver Propagation Delay	Receiver Input to Receiver Output, $C_L = 150pF$	$t_{PHL}$	25	-	0.20	-	$\mu s$
		$t_{PLH}$	25	-	0.30	-	$\mu s$
Receiver Output Enable Time	Normal Operation	25	-	200	-	ns	
Receiver Output Disable Time	Normal Operation	25	-	200	-	ns	
Transmitter Skew	$t_{PHL} - t_{PLH}$ (Note 5)	25	-	100	500	ns	
Receiver Skew	$t_{PHL} - t_{PLH}$	Full	-	100	1000	ns	
Transition Region Slew Rate	$V_{CC} = 3.3V$ , $R_L = 3k\Omega$ to $7k\Omega$ , Measured From $3V$ to $-3V$ or $-3V$ to $3V$	$C_L = 150pF$ to $2500pF$	25	4	-	30	V/ $\mu s$
		$C_L = 150pF$ to $1000pF$	25	6	-	30	V/ $\mu s$
<b>ESD Performance</b>							
RS-232 Pins ( $T1_{OUT}$ , $R1_{IN}$ )	Human Body Model	25	-	$\pm 15$	-	kV	
	IEC61000-4-2 Contact Discharge	25	-	$\pm 8$	-	kV	
	IEC61000-4-2 Air Gap Discharge	25	-	$\pm 15$	-	kV	
All Other Pins	Human Body Model	25	-	$\pm 3$	-	kV	

Note:

5. Transmitter skew is measured at the transmitter zero crossing points.

### 3. Typical Performance Curves

$V_{CC} = 3.3V, T_A = 25^\circ C$

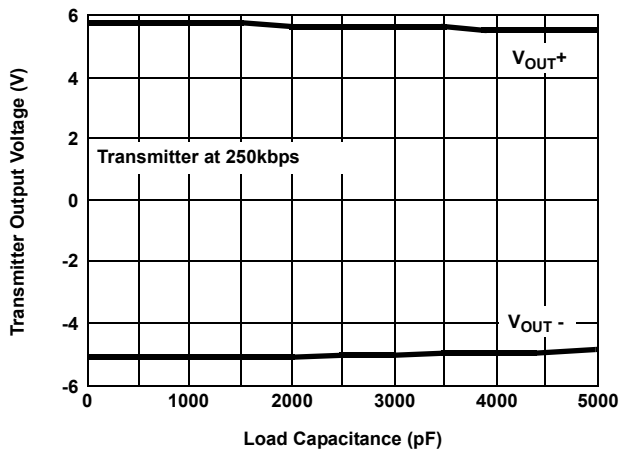

Figure 1. Transmitter Output Voltage vs Load Capacitance

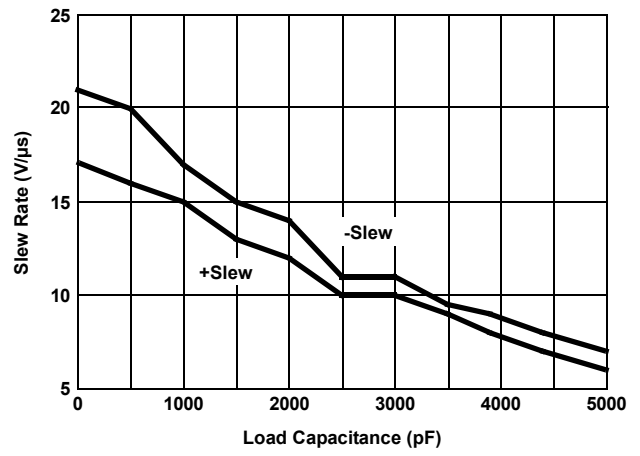

Figure 2. Slew Rate vs Load Capacitance

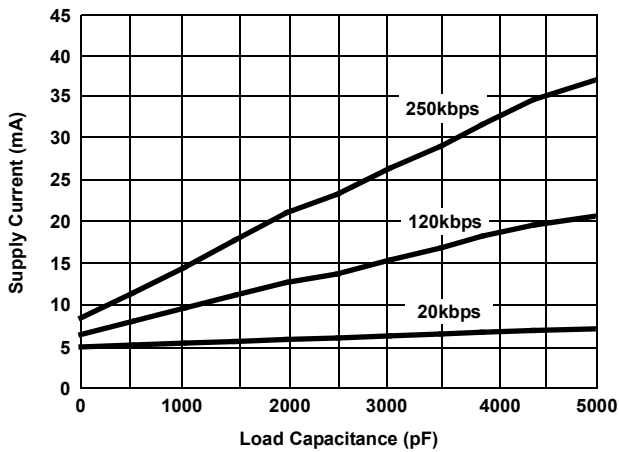

Figure 3. Supply Current vs Load Capacitance when Transmitting Data

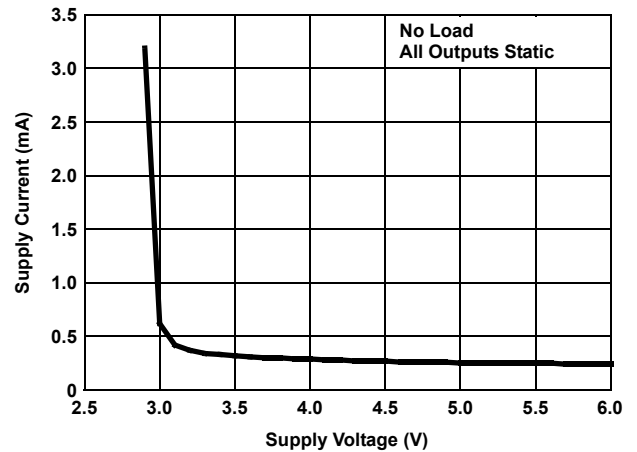

Figure 4. Supply Current vs Supply Voltage

## 4. Application Information

The ISL83220E operates from a single +3V to +5.5V supply, ensures a 250kbps minimum data rate, requires only four small external 0.1 $\mu$ F capacitors, features low power consumption, and meets all EIA RS-232C and V.28 specifications.

### 4.1 Charge Pump

The 3.3V ISL83220E uses regulated on-chip dual charge pumps as voltage doublers and voltage inverters to generate  $\pm 5.5$ V transmitter supplies from a  $V_{CC}$  supply as low as 3.0V. The charge pumps allow these devices to maintain RS-232 compliant output levels over the  $\pm 10\%$  tolerance range of 3.3V powered systems. The efficient on-chip power supplies require only four small, external 0.1 $\mu$ F capacitors for the voltage doubler and inverter functions, even at  $V_{CC} = 3.3$ V. The charge pumps operate discontinuously (turning off as soon as the V+ and V- supplies are pumped up to the nominal values) and provide significant power savings.

#### 4.1.1 Charge-Pump Abs Max Ratings

These 3V to 5V RS-232 transceivers have been fully characterized for 3.0V to 3.6V operation, and at critical points for 4.5V to 5.5V operation. Furthermore, load conditions were favorable using static logic states only.

The specified maximum values for V+ and V- are +7V and -7V, respectively. These limits apply for  $V_{CC}$  values set to 3.0V and 3.6V (see [Table 2](#)). For  $V_{CC}$  values set to 4.5V and 5.5V, the maximum values for V+ and V- can approach +9V and -7V, respectively ([Table 3 on page 8](#)). The breakdown characteristics for V+ and V- were measured with  $\pm 13$ V.

**Table 2. V+ and V- Values for  $V_{CC} = 3.0$ V to 3.6V**

C <sub>1</sub> ( $\mu$ F)	C <sub>2</sub> , C <sub>3</sub> , C <sub>4</sub> ( $\mu$ F)	Load	T1IN (Logic State)	V+ (V)		V- (V)	
				V <sub>CC</sub> = 3.0V	V <sub>CC</sub> = 3.6V	V <sub>CC</sub> = 3.0V	V <sub>CC</sub> = 3.6V
0.1	0.1	Open	H	5.80	6.56	-5.60	-5.88
			L	5.80	6.56	-5.60	-5.88
			2.4kbps	5.80	6.56	-5.60	-5.88
		3k $\Omega$ // 1000pF	H	5.88	6.60	-5.56	-5.92
			L	5.76	6.36	-5.56	-5.76
			2.4kbps	6.00	6.64	-5.64	-5.96
0.047	0.33	Open	H	5.68	6.00	-5.60	-5.60
			L	5.68	6.00	-5.60	-5.60
			2.4kbps	5.68	6.00	-5.60	-5.60
		3k $\Omega$ // 1000pF	H	5.76	6.08	-5.64	-5.64
			L	5.68	6.04	-5.60	-5.60
			2.4kbps	5.84	6.16	-5.64	-5.72
1	1	Open	H	5.88	6.24	-5.60	-5.60
			L	5.88	6.28	-5.60	-5.64
			2.4kbps	5.80	6.20	-5.60	-5.60
		3k $\Omega$ // 1000pF	H	5.88	6.44	-5.64	-5.72
			L	5.88	6.04	-5.64	-5.64
			2.4kbps	5.92	6.40	-5.64	-5.64

**Table 3. V+ and V- Values for  $V_{CC} = 4.5V$  to  $5.5V$** 

C <sub>1</sub> (μF)	C <sub>2</sub> , C <sub>3</sub> , C <sub>4</sub> (μF)	Load	T1IN (Logic State)	V+ (V)		V- (V)	
				V <sub>CC</sub> = 4.5V	V <sub>CC</sub> = 5.5V	V <sub>CC</sub> = 4.5V	V <sub>CC</sub> = 5.5V
0.1	0.1	Open	H	7.44	8.48	-6.16	-6.40
			L	7.44	8.48	-6.16	-6.44
			2.4kbps	7.44	8.48	-6.17	-6.44
		3kΩ // 1000pF	H	7.76	8.88	-6.36	-6.72
			L	7.08	8.00	-5.76	-5.76
			2.4kbps	7.76	8.84	-6.40	-6.64
0.047	0.33	Open	H	6.44	6.88	-5.80	-5.88
			L	6.48	6.88	-5.84	-5.88
			2.4kbps	6.44	6.88	-5.80	-5.88
		3kΩ // 1000pF	H	6.64	7.28	-5.92	-6.04
			L	6.24	6.60	-5.52	-5.52
			2.4kbps	6.72	7.16	-5.92	-5.96
1	1	Open	H	6.84	7.60	-5.76	-5.76
			L	6.88	7.60	-5.76	-5.76
			2.4kbps	6.92	7.56	-5.72	-5.76
		3kΩ // 1000pF	H	7.28	8.16	-5.80	-5.92
			L	6.44	6.84	-5.64	-6.84
			2.4kbps	7.08	7.76	-5.80	-5.80

The resulting new maximum voltages at V+ and V- are listed in [Table 4](#).

**Table 4. New Measured Withstanding Voltages**

V+, V- to Ground	±13V
V+ to V-	20V

## 4.2 Transmitters

The transmitters are proprietary, low dropout, inverting drivers that translate TTL/CMOS inputs to EIA/TIA-232 output levels. The transmitters are coupled with the on-chip ±5.5V supplies to deliver true RS-232 levels across a wide range of single supply system voltages.

The transmitter output disables and assumes a high impedance state when the device enters the powerdown mode (see [Table 5 on page 9](#)). The output can be driven to ±12V when disabled.

All devices ensure a 250kbps data rate for full load conditions (3kΩ and 1000pF),  $V_{CC} \geq 3.0V$ . Under more typical conditions of  $V_{CC} \geq 3.3V$ ,  $R_L = 3k\Omega$ , and  $C_L = 250pF$ , the ISL83220E easily operates at 900kbps.

**Note:** Transmitter inputs float if they remain unconnected and can increase  $I_{CC}$ .

## 4.3 Receivers

The ISL83220E contains a standard inverting receiver that tri-states from the  $\overline{EN}$  control line. Receivers convert RS-232 signals to CMOS output levels and accept inputs up to ±25V while presenting the required 3kΩ to 7kΩ input impedance (see [Figure 5 on page 9](#)) even if the power is off ( $V_{CC} = 0V$ ). The receiver's Schmitt trigger input stage uses hysteresis to increase noise immunity and decrease errors due to slow input signal transitions.

The ISL83220E receiver disables only when  $\overline{EN}$  is driven high (see [Table 5 on page 9](#)). This feature allows the receiver to monitor external devices such as a modem even when the ISL83220E is in its 1μA powerdown state.

Standard receivers driving powered down peripherals must be disabled to prevent current flow through the peripheral's protection diodes (see [Figure 6 on page 10](#)). The receivers cannot be used for wake up functions when they are disabled.

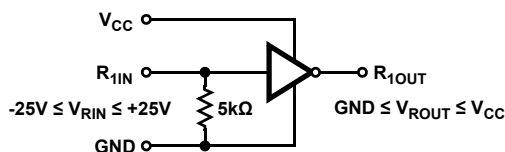

Figure 5. Inverting Receiver Connections

#### 4.4 Operation Down to 2.7V

The ISL83220E transmitter outputs meet RS-562 levels ( $\pm 3.7V$ ) at the full data rate with  $V_{CC}$  as low as 2.7V. RS-562 levels typically ensure interoperability with RS-232 devices.

#### 4.5 Powerdown Functionality

This 3V ISL83220E requires a nominal supply current of 0.3mA during normal operation (not in powerdown mode), which is considerably less than the 5mA to 11mA current required of 5V RS-232 devices. The already low current requirement drops significantly when the device enters powerdown mode. In powerdown, the supply current drops to  $1\mu A$  because the on-chip charge pump turns off ( $V+$  collapses to  $V_{CC}$ ,  $V-$  collapses to GND), and the transmitter outputs tri-state. This micro-power mode makes these devices ideal for battery powered and portable applications.

##### 4.5.1 Software Controlled (Manual) Powerdown

The ISL83220E's powerdown control is a simple shutdown ( $\overline{SHDN}$ ) pin. Driving this pin high enables normal operation. Driving the pin low forces the IC into its powerdown state. Connect  $\overline{SHDN}$  to  $V_{CC}$  if the powerdown function is not needed. **Note:** The receiver output remains enabled during shutdown (see [Table 5](#)). For the lowest power consumption during powerdown, disable the receiver by driving the  $\overline{EN}$  input high (see [Receiver ENABLE Control](#)). The time to recover from manual powerdown mode is typically 100 $\mu s$ .

Table 5. Powerdown and Enable Logic Truth Table

SHDN Input	$\overline{EN}$ Input	Transmitter Output	Receiver Output	Mode of Operation
L	L	High-Z	Active	Manual Powerdown
L	H	High-Z	High-Z	Manual Powerdown with Receiver Disabled
H	L	Active	Active	Normal Operation
H	H	Active	High-Z	Normal Operation with Receiver Disabled

#### 4.6 Receiver ENABLE Control

The ISL83220E's  $\overline{EN}$  input controls the receiver output. Driving  $\overline{EN}$  high disables the receiver output and places it in a high impedance state. Disabling the receiver output is useful for eliminating the supply current, due to a receiver output forward biasing the protection diode when driving the input of a powered down ( $V_{CC} = GND$ ) peripheral (see [Figure 6 on page 10](#)).

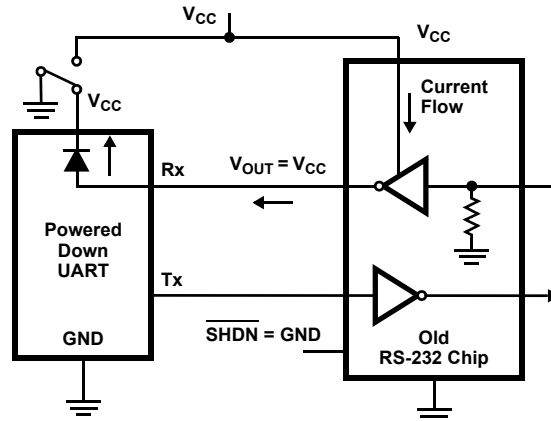

Figure 6. Power Drain Through Powered Down Peripheral

### 4.7 Capacitor Selection

The charge pumps require 0.1µF capacitors for 3.3V operation. Do not use values smaller than 0.1µF. Increasing the capacitor values (by a factor of 2) reduces ripple on the transmitter outputs and slightly reduces power consumption. When using minimum required capacitor values, make sure that capacitor values do not degrade excessively with temperature. If in doubt, use capacitors with a larger nominal value. The capacitor's Equivalent Series Resistance (ESR) usually rises at low temperatures and it influences the amount of ripple on V+ and V-.

### 4.8 Power Supply Decoupling

In most circumstances, a 0.1µF bypass capacitor is adequate. In applications that are particularly sensitive to power supply noise, decouple V<sub>CC</sub> to ground with a capacitor of the same value as the charge-pump capacitor C<sub>1</sub>. Connect the bypass capacitor as close as possible to the IC.

### 4.9 Transmitter Output when Exiting Powerdown

Figure 7 shows the response of the transmitter output when exiting powerdown mode. As the transmitter output activates, it properly goes to RS-232 levels with no glitching, ringing, or undesirable transients. The transmitter is loaded with 3kΩ in parallel with 2500pF. **Note:** The transmitter enables only when the magnitude of the supplies exceed approximately 3V.

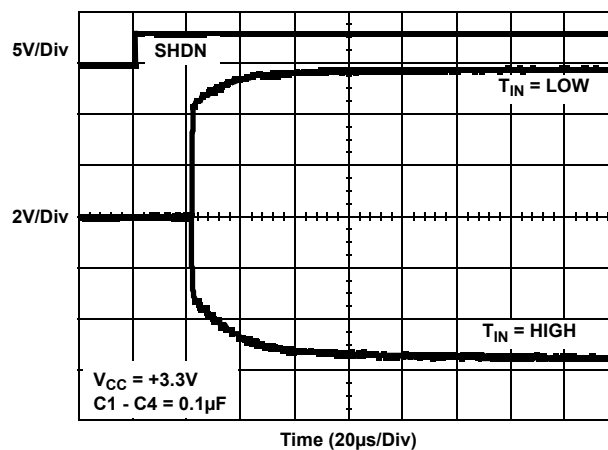

Figure 7. Transmitter Output when Exiting Powerdown

### 4.10 High Data Rates

The ISL83220E maintains the RS-232  $\pm 5V$  minimum transmitter output voltages, even at high data rates. [Figure 8](#) shows a transmitter loopback test circuit. [Figure 9](#) shows the loopback test result at 120kbps. For this test, the transmitter is driving an RS-232 load in parallel with 1000pF at 120kbps. [Figure 10](#) shows the loopback results for the transmitter driving 1000pF and an RS-232 load at 250kbps.

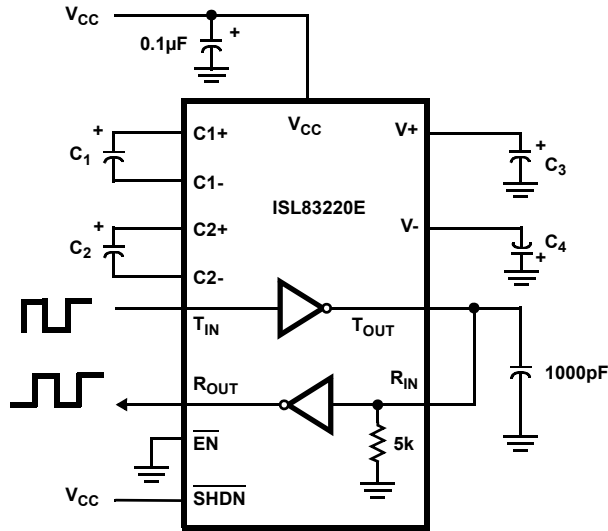

Figure 8. Transmitter Loopback Test Circuit

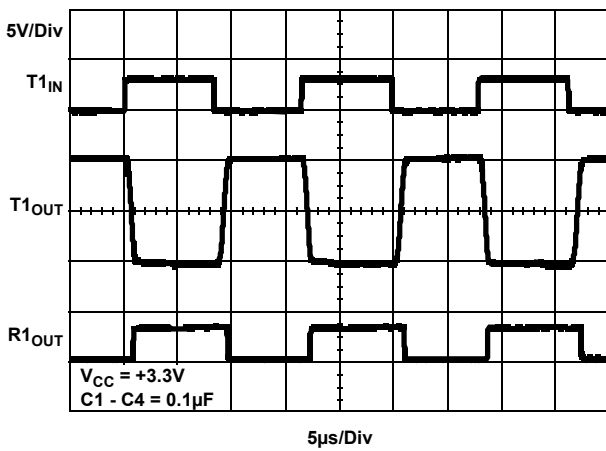

Figure 9. Loopback Test at 120kbps

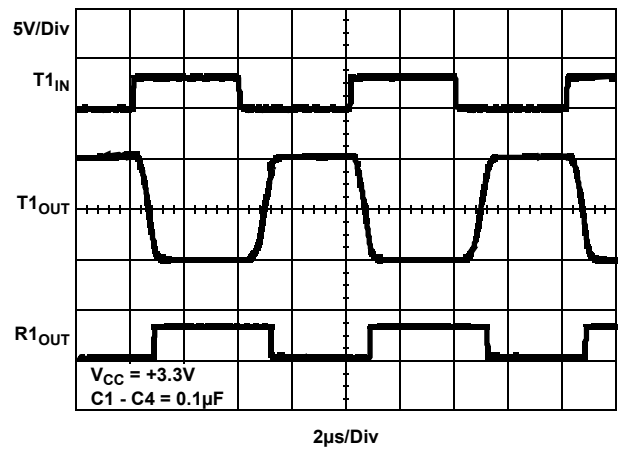

Figure 10. Loopback Test at 250kbps

#### 4.11 Interconnection with 3V and 5V Logic

The ISL83220E directly interfaces with 5V CMOS and TTL logic families. AC, HC, and CD4000 outputs can drive ISL83220E inputs with the device at 3.3V and the logic supply at 5V, but ISL83220E outputs do not reach the minimum  $V_{IH}$  for these logic families. See [Table 6](#) for more information.

**Table 6. Logic Family Compatibility with Various Supply Voltages**

System Power-Supply Voltage (V)	V <sub>CC</sub> Supply Voltage (V)	Compatibility
3.3	3.3	Compatible with all CMOS families.
5	5	Compatible with all TTL and CMOS logic families.
5	3.3	Compatible with ACT and HCT CMOS, and with TTL. ISL83220E outputs are incompatible with AC, HC, and CD4000 CMOS inputs.

## 5. ±15kV ESD Protection

All pins on the ISL8xxx devices include ESD protection structures, but the ISL8xxxE family incorporates advanced structures that allow the RS-232 pins (transmitter outputs and receiver inputs) to survive ESD events up to ±15kV. The RS-232 pins are particularly vulnerable to ESD damage because they typically connect to an exposed port on the exterior of the finished product. Touching the port pins or connecting a cable can cause an ESD event that might destroy unprotected ICs. The ESD structures protect the device whether or not it is powered up, protect without allowing any latchup mechanism to activate, and do not interfere with RS-232 signals as large as ±25V.

### 5.1 Human Body Model (HBM) Testing

The Human Body Model (HBM) test method emulates the ESD event delivered to an IC during human handling. The tester delivers the charge through a 1.5kΩ current limiting resistor and makes the test less severe than the IEC61000 test, which uses a 330Ω limiting resistor. The HBM method determines an IC's ability to withstand the ESD transients typically present during handling and manufacturing. Due to the random nature of these events, each pin is tested with respect to all other pins. The RS-232 pins on "E" family devices can withstand HBM ESD events to ±15kV.

### 5.2 IEC61000-4-2 Testing

The IEC61000 test method applies to finished equipment rather than to an individual IC. Therefore, the pins most likely to suffer an ESD event are those that are exposed to the outside world (the RS-232 pins in this case), and the IC is tested in its typical application configuration (power applied) rather than testing each pin-to-pin combination. The lower current limiting resistor coupled with the larger charge storage capacitor yields a test that is much more severe than the HBM test. The extra ESD protection built into this device's RS-232 pins allows the design of equipment that meets level 4 criteria without the need for additional board level protection on the RS-232 port.

### 5.3 Air-Gap Discharge Test Method

For the air-gap discharge test method, a charged probe tip moves toward the IC pin until the voltage arcs to it. The current waveform delivered to the IC pin depends on factors such as approach speed, humidity, temperature, so it is difficult to obtain repeatable results. The "E" device RS-232 pins withstand ±15kV air-gap discharges.

### 5.4 Contact Discharge Test Method

During the contact discharge test, the probe contacts the tested pin before the probe tip is energized and eliminates the variables associated with the air-gap discharge. The result is a more repeatable and predictable test, but equipment limits prevent testing devices at voltages higher than ±8kV. All "E" family devices survive ±8kV contact discharges on the RS-232 pins.

---

## 6. Die Characteristics

Substrate Potential (Powered Up)	GND
Transistor Count	286
Process	Si Gate CMOS

## 7. Revision History

Rev.	Date	Description
6.00	Apr.26.19	Updated Related Literature section. Ordering Information on page 2: Added Tape and Reel column Removed obsolete parts Added notes 1-3. Added Charge Pump Abs Max Ratings section starting on page 7. Updated package outline drawing to version 2. Convert to new POD format by moving dimensions from table onto drawing and adding land pattern. No dimension changes. Applied new template.

# 8. Package Outline Drawing

For the most recent package outline drawing, see [M16.173](#).

M16.173  
 16 Lead Thin Shrink Small Outline Package (TSSOP)  
 Rev 2, 5/10

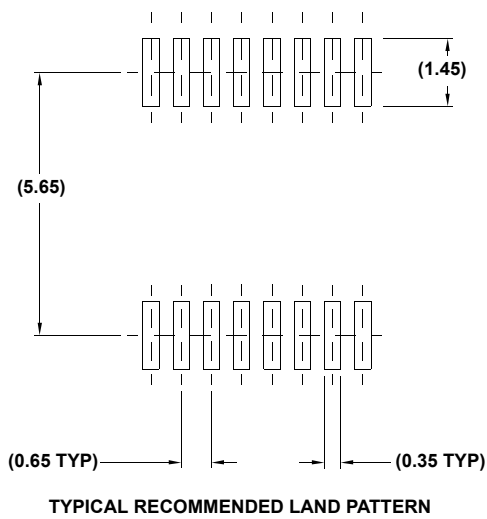
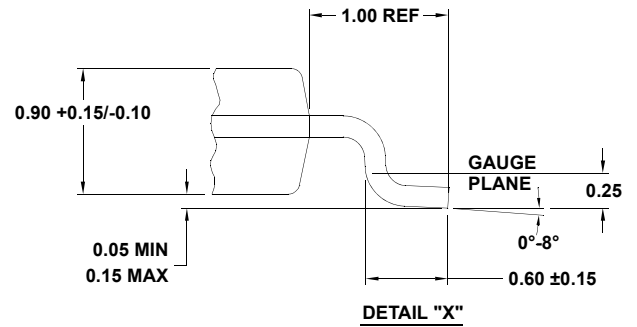
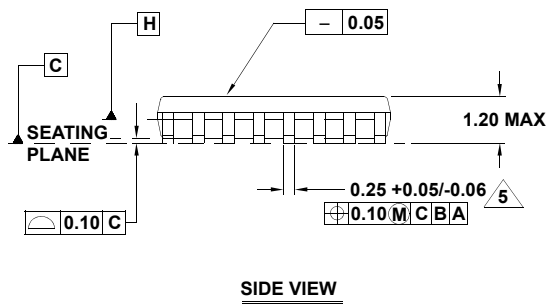
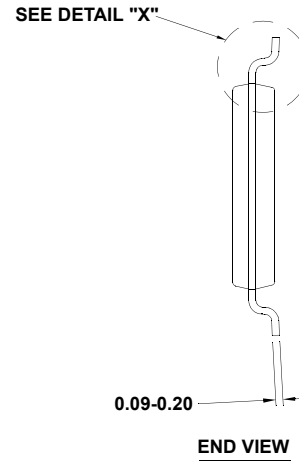
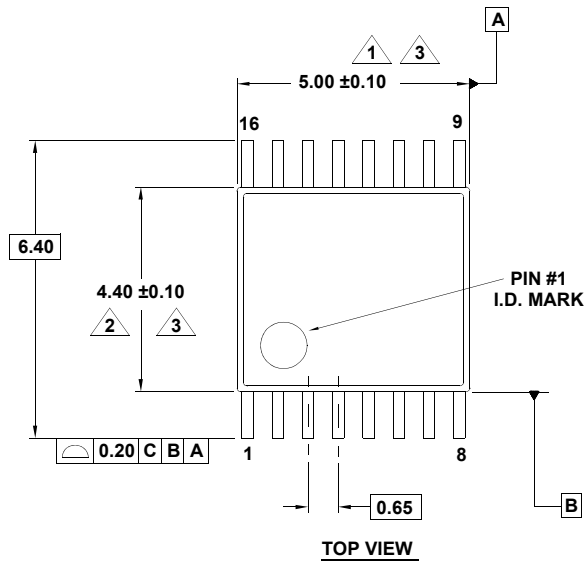

**NOTES:**

1. Dimension does not include mold flash, protrusions or gate burrs. Mold flash, protrusions or gate burrs shall not exceed 0.15 per side.
2. Dimension does not include interlead flash or protrusion. Interlead flash or protrusion shall not exceed 0.25 per side.
3. Dimensions are measured at datum plane H.
4. Dimensioning and tolerancing per ASME Y14.5M-1994.
5. Dimension does not include dambar protrusion. Allowable protrusion shall be 0.08mm total in excess of dimension at maximum material condition. Minimum space between protrusion and adjacent lead is 0.07mm.
6. Dimension in ( ) are for reference only.
7. Conforms to JEDEC MO-153.

## Notice

1. Descriptions of circuits, software and other related information in this document are provided only to illustrate the operation of semiconductor products and application examples. You are fully responsible for the incorporation or any other use of the circuits, software, and information in the design of your product or system. Renesas Electronics disclaims any and all liability for any losses and damages incurred by you or third parties arising from the use of these circuits, software, or information.
2. Renesas Electronics hereby expressly disclaims any warranties against and liability for infringement or any other claims involving patents, copyrights, or other intellectual property rights of third parties, by or arising from the use of Renesas Electronics products or technical information described in this document, including but not limited to, the product data, drawings, charts, programs, algorithms, and application examples.
3. No license, express, implied or otherwise, is granted hereby under any patents, copyrights or other intellectual property rights of Renesas Electronics or others.
4. You shall not alter, modify, copy, or reverse engineer any Renesas Electronics product, whether in whole or in part. Renesas Electronics disclaims any and all liability for any losses or damages incurred by you or third parties arising from such alteration, modification, copying or reverse engineering.
5. Renesas Electronics products are classified according to the following two quality grades: "Standard" and "High Quality". The intended applications for each Renesas Electronics product depends on the product's quality grade, as indicated below.
  - "Standard": Computers; office equipment; communications equipment; test and measurement equipment; audio and visual equipment; home electronic appliances; machine tools; personal electronic equipment; industrial robots; etc.
  - "High Quality": Transportation equipment (automobiles, trains, ships, etc.); traffic control (traffic lights); large-scale communication equipment; key financial terminal systems; safety control equipment; etc.Unless expressly designated as a high reliability product or a product for harsh environments in a Renesas Electronics data sheet or other Renesas Electronics document, Renesas Electronics products are not intended or authorized for use in products or systems that may pose a direct threat to human life or bodily injury (artificial life support devices or systems; surgical implantations; etc.), or may cause serious property damage (space system; undersea repeaters; nuclear power control systems; aircraft control systems; key plant systems; military equipment; etc.). Renesas Electronics disclaims any and all liability for any damages or losses incurred by you or any third parties arising from the use of any Renesas Electronics product that is inconsistent with any Renesas Electronics data sheet, user's manual or other Renesas Electronics document.
6. When using Renesas Electronics products, refer to the latest product information (data sheets, user's manuals, application notes, "General Notes for Handling and Using Semiconductor Devices" in the reliability handbook, etc.), and ensure that usage conditions are within the ranges specified by Renesas Electronics with respect to maximum ratings, operating power supply voltage range, heat dissipation characteristics, installation, etc. Renesas Electronics disclaims any and all liability for any malfunctions, failure or accident arising out of the use of Renesas Electronics products outside of such specified ranges.
7. Although Renesas Electronics endeavors to improve the quality and reliability of Renesas Electronics products, semiconductor products have specific characteristics, such as the occurrence of failure at a certain rate and malfunctions under certain use conditions. Unless designated as a high reliability product or a product for harsh environments in a Renesas Electronics data sheet or other Renesas Electronics document, Renesas Electronics products are not subject to radiation resistance design. You are responsible for implementing safety measures to guard against the possibility of bodily injury, injury or damage caused by fire, and/or danger to the public in the event of a failure or malfunction of Renesas Electronics products, such as safety design for hardware and software, including but not limited to redundancy, fire control and malfunction prevention, appropriate treatment for aging degradation or any other appropriate measures. Because the evaluation of microcomputer software alone is very difficult and impractical, you are responsible for evaluating the safety of the final products or systems manufactured by you.
8. Please contact a Renesas Electronics sales office for details as to environmental matters such as the environmental compatibility of each Renesas Electronics product. You are responsible for carefully and sufficiently investigating applicable laws and regulations that regulate the inclusion or use of controlled substances, including without limitation, the EU RoHS Directive, and using Renesas Electronics products in compliance with all these applicable laws and regulations. Renesas Electronics disclaims any and all liability for damages or losses occurring as a result of your noncompliance with applicable laws and regulations.
9. Renesas Electronics products and technologies shall not be used for or incorporated into any products or systems whose manufacture, use, or sale is prohibited under any applicable domestic or foreign laws or regulations. You shall comply with any applicable export control laws and regulations promulgated and administered by the governments of any countries asserting jurisdiction over the parties or transactions.
10. It is the responsibility of the buyer or distributor of Renesas Electronics products, or any other party who distributes, disposes of, or otherwise sells or transfers the product to a third party, to notify such third party in advance of the contents and conditions set forth in this document.
11. This document shall not be reprinted, reproduced or duplicated in any form, in whole or in part, without prior written consent of Renesas Electronics.
12. Please contact a Renesas Electronics sales office if you have any questions regarding the information contained in this document or Renesas Electronics products.

(Note1) "Renesas Electronics" as used in this document means Renesas Electronics Corporation and also includes its directly or indirectly controlled subsidiaries.

(Note2) "Renesas Electronics product(s)" means any product developed or manufactured by or for Renesas Electronics.

(Rev.4.0-1 November 2017)

## Corporate Headquarters

TOYOSU FORESIA, 3-2-24 Toyosu,  
Koto-ku, Tokyo 135-0061, Japan  
[www.renesas.com](http://www.renesas.com)

## Contact Information

For further information on a product, technology, the most up-to-date version of a document, or your nearest sales office, please visit:  
[www.renesas.com/contact/](http://www.renesas.com/contact/)

## Trademarks

Renesas and the Renesas logo are trademarks of Renesas Electronics Corporation. All trademarks and registered trademarks are the property of their respective owners.

## Looking for pricing, stock, or lifecycle information?

Click below to explore more details on WIN SOURCE:

 [View ISL83220ECVZ on WIN SOURCE](#)

 [Intersil Information](#)

## Optimize Your Supply Chain with WIN SOURCE Solutions

-  Global Sourcing Solution
-  Obsolete Management
-  Cost Control Management
-  Shortage Management
-  Alternative Solution
-  Excess Inventory Management