



**THE DATASHEET OF  
ISL81487EIPZ**



## ISL8487E, ISL81487L, ISL81487E

±15kV ESD Protected, 1/8 Unit Load, 5V, Low Power, High Speed or Slew Rate Limited RS-485/RS-422 Transceivers

FN6051  
Rev.8.00  
Sep 20, 2018

The [ISL8487E](#), [ISL81487L](#), and [ISL81487E](#) RS-485/RS-422 devices are ESD protected, fractional unit load (UL), BiCMOS, 5V powered, single transceivers that meet both the RS-485 and RS-422 standards for balanced communication. Each driver output/receiver input is protected against ±15kV ESD strikes without latch-up. Unlike competitive devices, this device family is specified for 10% tolerance supplies (4.5V to 5.5V).

All devices present a 1/8 unit load to the RS-485 bus, which allows up to 256 transceivers on the network for large node count systems (for example, process automation and remote meter reading systems). In a remote utility meter reading system, individual utility meter readings (in apartments, for example) are routed to a concentrator with an RS-485 network, so the high allowed node count minimizes the number of repeaters required to network all the meters. Data for all meters is then read out from the concentrator from a single access port or a wireless link.

Slew rate limited drivers on the ISL8487E and ISL81487L reduce EMI and minimize reflections from improperly terminated transmission lines or unterminated stubs in multidrop and multipoint applications. Data rates up to 250kbps are achievable with these devices.

Data rates up to 5Mbps are achievable by using the ISL81487E, which features higher slew rates.

The receiver (Rx) inputs feature a “fail-safe if open” design, which ensures a logic high Rx output if Rx inputs are floating.

The driver (Tx) outputs are short-circuit protected, even for voltages exceeding the power supply voltage. Additionally, on-chip thermal shutdown circuitry disables the Tx outputs to prevent damage if power dissipation becomes excessive.

The half duplex devices multiplex the Rx inputs and Tx outputs to allow transceivers with Rx and Tx disable functions in 8 lead packages.

### Related Literature

For a full list of related documents, visit our website:

- [ISL8487E](#), [ISL81487L](#), and [ISL81487E](#) product pages

### Features

- RS-485 I/O pin ESD protection . . . . . ±15kV HBM  
- Class 3 ESD level on all other pins . . . . . >7kV HBM
- Fractional unit load allows up to 256 devices on the bus
- Specified for 10% tolerance supplies
- High data rate version (ISL81487E). . . . . up to 5Mbps
- Slew rate limited versions for error free data transmission (ISL8487E, ISL81487L) . . . . up to 250kbps
- Low current shutdown mode (except ISL81487E) . . . 0.5µA
- Low quiescent supply current:  
- ISL8487E, ISL81487L . . . . . 145µA (maximum)  
- ISL81487E . . . . . 420µA (maximum)
- -7V to +12V common mode input voltage range
- Three state Rx and Tx outputs
- 30ns propagation delays, 5ns skew (ISL81487E)
- Half duplex pinouts
- Operate from a single +5V supply (10% tolerance)
- Current limiting and thermal shutdown for driver overload protection
- Pin compatible replacements for: MAX487E, (ISL8487E); LTC1487, ADM1487 (ISL81487L); MAX1487E, ST485ER (ISL81487E)
- Pb-free plus anneal available (RoHS compliant)

### Applications

- High node count networks
- Automated utility meter reading systems
- Factory automation
- Security networks
- Building environmental control systems
- Industrial/process control networks

TABLE 1. SUMMARY OF FEATURES

PART NUMBER	HALF/FULL DUPLEX	NO. OF DEVICES ALLOWED ON BUS	DATA RATE (Mbps)	SLEW RATE LIMITED?	RECEIVER/ DRIVER ENABLE?	QUIESCENT I <sub>CC</sub> (µA)	LOW POWER SHUTDOWN?	PIN COUNT
ISL8487E	Half	256	0.25	Yes	Yes	120	Yes	8
ISL81487L	Half	256	0.25	Yes	Yes	120	Yes	8
ISL81487E	Half	256	5	No	Yes	350	No	8

## Typical Operating Circuits

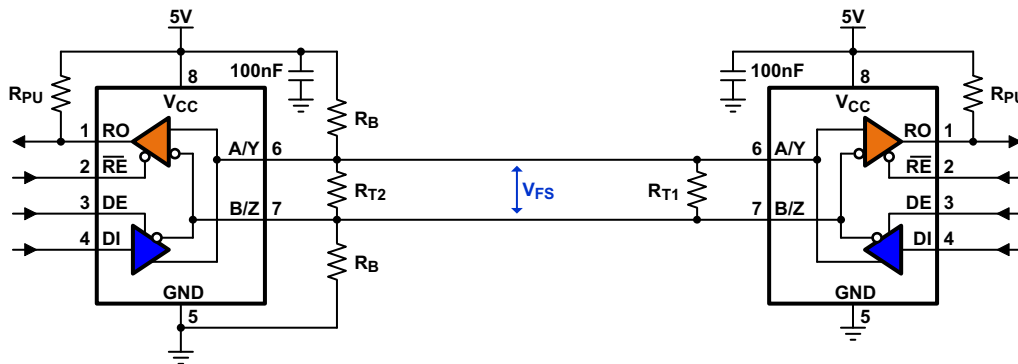

To calculate the resistor values, refer to [TB509](#).

## Ordering Information

PART NUMBER ( )	PART MARKING	TEMP. RANGE (°C)	TAPE AND REEL (UNITS) ( <a href="#">Note 1</a> )	PACKAGE	PKG. DWG. #
ISL8487EIBZ	8487EIBZ	-40 to +85	-	8 Ld SOIC (Pb-free)	M8.15
ISL8487EIBZ-T	8487EIBZ	-40 to +85	2.5k	8 Ld SOIC (Pb-free)	M8.15
ISL8487EIPZ (not recommended for new designs, recommended replacement ISL81487LIPZ)	8487EIPZ	-40 to +85	-	8 Ld PDIP (Pb-free, <a href="#">Note 4</a> )	E8.3
ISL81487LIBZ	81487LIBZ	-40 to +85	-	8 Ld SOIC (Pb-free)	M8.15
ISL81487LIBZ-T	81487LIBZ	-40 to +85	2.5k	8 Ld SOIC (Pb-free)	M8.15
ISL81487LIPZ	81487LIPZ	-40 to +85	-	8 Ld PDIP (Pb-free, <a href="#">Note 4</a> )	E8.3
ISL81487EIBZ	81487EIBZ	-40 to +85	-	8 Ld SOIC (Pb-free)	M8.15
ISL81487EIBZ-T	81487EIBZ	-40 to +85	2.5k	8 Ld SOIC (Pb-free)	M8.15
ISL81487EIPZ	ISL81487EIPZ	-40 to +85	-	8 Ld PDIP (Pb-free, <a href="#">Note 4</a> )	E8.3

### NOTES:

1. Refer to [TB347](#) for details about reel specifications.
2. Pb-free plus anneal products employ special Pb-free material sets; molding compounds/die attach materials and 100% matte tin plate termination finish, which are RoHS compliant and compatible with both SnPb and Pb-free soldering operations. Pb-free products are MSL classified at Pb-free peak reflow temperatures that meet or exceed the Pb-free requirements of IPC/JEDEC J STD-020
3. For Moisture Sensitivity Level (MSL), see the [ISL8487E](#), [ISL81487L](#), and [ISL81487E](#) product information pages. For more information about MSL, see [TB363](#).
4. Pb-free PDIPs can be used for through hole wave solder processing only. They are not intended for use in Reflow solder processing applications.

**Pinout**

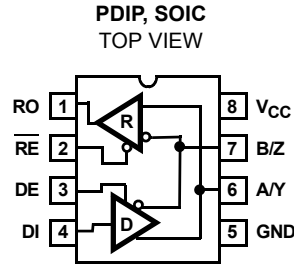

**Pin Descriptions**

PIN	FUNCTION
RO	Receiver output. RO is high if A > B by at least 0.2V; RO is low if A < B by 0.2V or more; RO is high if A and B are unconnected (floating).
$\overline{RE}$	Receiver output enable. RO is enabled when $\overline{RE}$ is low; RO is high impedance when $\overline{RE}$ is high.
DE	Driver output enable. The driver outputs Y and Z are enabled by bringing DE high. They are high impedance when DE is low.
DI	Driver input. A low on DI forces output Y low and output Z high. Similarly, a high on DI forces output Y high and output Z low.
GND	Ground connection.
A/Y	$\pm 15\text{kV}$ HBM ESD protected, RS-485/422 level, noninverting receiver input and noninverting driver output. Pin is an input (A) if DE = 0; pin is an output (Y) if DE = 1.
B/Z	$\pm 15\text{kV}$ HBM ESD protected, RS-485/422 level, inverting receiver input and inverting driver output. Pin is an input (B) if DE = 0; pin is an output (Z) if DE = 1.
V <sub>CC</sub>	System power supply input (4.5V to 5.5V).

**Truth Tables**

TRANSMITTING				
INPUTS			OUTPUTS	
$\overline{RE}$	DE	DI	Z	Y
X	1	1	0	1
X	1	0	1	0
0	0	X	High-Z	High-Z
1	0	X	High-Z <a href="#">(Note 12)</a>	High-Z <a href="#">(Note 12)</a>

RECEIVING			
INPUTS			OUTPUT
$\overline{RE}$	DE	A-B	RO
0	X	$\geq +0.2\text{V}$	1
0	X	$\leq -0.2\text{V}$	0
0	X	Inputs Open	1
1	X	X	High-Z <a href="#">(Note 12)</a>
1	0	X	High-Z

**Absolute Maximum Ratings**

V<sub>CC</sub> to Ground ..... 7V  
 Input Voltages  
 DI, DE, RE ..... -0.5V to (V<sub>CC</sub> +0.5V)  
 Input/Output Voltages  
 A/Y, B/Z ..... -8V to +12.5V  
 RO ..... -0.5V to (V<sub>CC</sub> +0.5V)  
 Short-Circuit Duration  
 Y, Z ..... Continuous  
 ESD Rating ..... See "Electrical Specifications"

**Thermal Information**

Thermal Resistance (Typical, [Note 5](#)) θ<sub>JA</sub> (°C/W)  
 8 Ld SOIC Package ..... 170  
 8 Ld PDIP Package ([Note 6](#)) ..... 140  
 Maximum Junction Temperature (Plastic Package) ..... 150°C  
 Maximum Storage Temperature Range ..... -65°C to 150°C  
 Maximum Lead Temperature (Soldering 10s) ..... 300°C  
 (SOIC - Lead Tips Only)

**Operating Conditions**

Temperature Range  
 ISL8XXXIX ..... -40°C to 85°C

*CAUTION: Stresses above those listed in "Absolute Maximum Ratings" can permanently damage the device. This is a stress only rating and operation of the device at these or any other conditions above those indicated in the operational sections of this specification is not implied.*

NOTES:

5. θ<sub>JA</sub> is measured with the component mounted on a low-effective thermal conductivity test board in free air. See [TB379](#) for details.
6. Pb-free PDIPs can be used for through hole wave solder processing only. They are not intended for use in Reflow solder processing applications.

**Electrical Specifications** Test Conditions: V<sub>CC</sub> = 4.5V to 5.5V; Unless Otherwise Specified. Typicals are at V<sub>CC</sub> = 5V, T<sub>A</sub> = +25°C, [Note 7](#)

PARAMETER	SYMBOL	TEST CONDITIONS	TEMP (°C)	MIN	TYP	MAX	UNIT	
<b>DC CHARACTERISTICS</b>								
Driver Differential V <sub>OUT</sub> (No Load)	V <sub>OD1</sub>		Full	-	-	V <sub>CC</sub>	V	
Driver Differential V <sub>OUT</sub> (with Load)	V <sub>OD2</sub>	R = 50Ω (RS-422), ( <a href="#">Figure 1</a> )	Full	2	3	-	V	
		R = 27Ω (RS-485), ( <a href="#">Figure 1</a> )	Full	1.5	2.3	5	V	
Change in Magnitude of Driver Differential V <sub>OUT</sub> for Complementary Output States	ΔV <sub>OD</sub>	R = 27Ω or 50Ω, ( <a href="#">Figure 1</a> )	Full	-	0.01	0.2	V	
Driver Common-Mode V <sub>OUT</sub>	V <sub>OC</sub>	R = 27Ω or 50Ω, ( <a href="#">Figure 1</a> )	Full	-	-	3	V	
Change in Magnitude of Driver Common-Mode V <sub>OUT</sub> for Complementary Output States	ΔV <sub>OC</sub>	R = 27Ω or 50Ω, ( <a href="#">Figure 1</a> )	Full	-	0.01	0.2	V	
Logic Input High Voltage	V <sub>IH</sub>	DE, DI, $\overline{RE}$	Full	2	-	-	V	
Logic Input Low Voltage	V <sub>IL</sub>	DE, DI, $\overline{RE}$	Full	-	-	0.8	V	
Logic Input Current	I <sub>IN1</sub>	DE, DI, $\overline{RE}$	Full	-2	-	2	μA	
Input Current (A/Y, B/Z), ( <a href="#">Note 15</a> )	I <sub>IN2</sub>	DE = 0V, V <sub>CC</sub> = 4.5 to 5.5V	V <sub>IN</sub> = 12V	Full	-	-	140	μA
			V <sub>IN</sub> = -7V	Full	-	-	-120	μA
	I <sub>IN2</sub>	DE = 0V, V <sub>CC</sub> = 0V	V <sub>IN</sub> = 12V	Full	-	-	180	μA
			V <sub>IN</sub> = -7V	Full	-	-	-100	μA
Receiver Differential Threshold Voltage	V <sub>TH</sub>	-7V ≤ V <sub>CM</sub> ≤ 12V	Full	-0.2	-	0.2	V	
Receiver Input Hysteresis	ΔV <sub>TH</sub>	V <sub>CM</sub> = 0V	25	-	70	-	mV	
Receiver Output High Voltage	V <sub>OH</sub>	I <sub>O</sub> = -4mA, V <sub>ID</sub> = 200mV	Full	3.5	-	-	V	
Receiver Output Low Voltage	V <sub>OL</sub>	I <sub>O</sub> = -4mA, V <sub>ID</sub> = 200mV	Full	-	-	0.4	V	
Three-State (High Impedance) Receiver Output Current	I <sub>OZR</sub>	0.4V ≤ V <sub>O</sub> ≤ 2.4V	Full	-	-	±1	μA	
Receiver Input Resistance	R <sub>IN</sub>	-7V ≤ V <sub>CM</sub> ≤ 12V	Full	96	-	-	kΩ	

**Electrical Specifications** Test Conditions:  $V_{CC} = 4.5V$  to  $5.5V$ ; Unless Otherwise Specified. Typical values are at  $V_{CC} = 5V$ ,  $T_A = +25^\circ C$ , [Note 7 \(Continued\)](#)

PARAMETER	SYMBOL	TEST CONDITIONS	TEMP (°C)	MIN	TYP	MAX	UNIT	
No-Load Supply Current, ( <a href="#">Note 8</a> )	$I_{CC}$	ISL81487E, DI, $\overline{RE} = 0V$ or $V_{CC}$	DE = $V_{CC}$	Full	-	400	500	$\mu A$
			DE = 0V	Full	-	350	420	$\mu A$
		ISL8487E, ISL81487L, DI, $\overline{RE} = 0V$ or $V_{CC}$	DE = $V_{CC}$	Full	-	160	200	$\mu A$
			DE = 0V	Full	-	120	145	$\mu A$
Shutdown Supply Current	$I_{SHDN}$	( <a href="#">Note 12</a> ), DE = 0V, $\overline{RE} = V_{CC}$ , DI = 0V or $V_{CC}$	Full	-	0.5	8	$\mu A$	
Driver Short-Circuit Current, $V_O =$ High or Low	$I_{OSD1}$	DE = $V_{CC}$ , $-7V \leq V_Y$ or $V_Z \leq 12V$ , ( <a href="#">Note 9</a> )	Full	35	-	250	mA	
Receiver Short-Circuit Current	$I_{OSR}$	$0V \leq V_O \leq V_{CC}$	Full	7	-	85	mA	
<b>SWITCHING CHARACTERISTICS (ISL81487E)</b>								
Driver Input to Output Delay	$t_{PLH}$ , $t_{PHL}$	$R_{DIFF} = 54\Omega$ , $C_L = 100pF$ , ( <a href="#">Figure 2</a> )	Full	15	24	50	ns	
Driver Output Skew	$t_{SKEW}$	$R_{DIFF} = 54\Omega$ , $C_L = 100pF$ , ( <a href="#">Figure 2</a> )	Full	-	3	10	ns	
Driver Differential Rise or Fall Time	$t_R$ , $t_F$	$R_{DIFF} = 54\Omega$ , $C_L = 100pF$ , ( <a href="#">Figure 2</a> )	Full	3	12	25	ns	
Driver Enable to Output High	$t_{ZH}$	$C_L = 100pF$ , SW = GND, ( <a href="#">Figure 2</a> )	Full	-	14	70	ns	
Driver Enable to Output Low	$t_{ZL}$	$C_L = 100pF$ , SW = $V_{CC}$ , ( <a href="#">Figure 2</a> )	Full	-	14	70	ns	
Driver Disable from Output High	$t_{HZ}$	$C_L = 15pF$ , SW = GND, ( <a href="#">Figure 2</a> )	Full	-	44	70	ns	
Driver Disable from Output Low	$t_{LZ}$	$C_L = 15pF$ , SW = $V_{CC}$ , ( <a href="#">Figure 2</a> )	Full	-	21	70	ns	
Receiver Input to Output Delay	$t_{PLH}$ , $t_{PHL}$	( <a href="#">Figure 4</a> )	Full	30	90	150	ns	
Receiver Skew   $t_{PLH} - t_{PHL}$	$t_{SKD}$	( <a href="#">Figure 4</a> )	25	-	5	-	ns	
Receiver Enable to Output High	$t_{ZH}$	$C_L = 15pF$ , SW = GND, ( <a href="#">Figure 5</a> )	Full	-	9	50	ns	
Receiver Enable to Output Low	$t_{ZL}$	$C_L = 15pF$ , SW = $V_{CC}$ , ( <a href="#">Figure 5</a> )	Full	-	9	50	ns	
Receiver Disable from Output High	$t_{HZ}$	$C_L = 15pF$ , SW = GND, ( <a href="#">Figure 5</a> )	Full	-	9	50	ns	
Receiver Disable from Output Low	$t_{LZ}$	$C_L = 15pF$ , SW = $V_{CC}$ , ( <a href="#">Figure 5</a> )	Full	-	9	50	ns	
Maximum Data Rate	$f_{MAX}$		Full	5	-	-	Mbps	
<b>SWITCHING CHARACTERISTICS (ISL8487E)</b>								
Driver Input to Output Delay	$t_{PLH}$ , $t_{PHL}$	$R_{DIFF} = 54\Omega$ , $C_L = 100pF$ , ( <a href="#">Figure 2</a> )	Full	250	650	2000	ns	
Driver Output Skew	$t_{SKEW}$	$R_{DIFF} = 54\Omega$ , $C_L = 100pF$ , ( <a href="#">Figure 2</a> )	Full	-	160	800	ns	
Driver Differential Rise or Fall Time	$t_R$ , $t_F$	$R_{DIFF} = 54\Omega$ , $C_L = 100pF$ , ( <a href="#">Figure 2</a> )	Full	250	900	2000	ns	
Driver Enable to Output High	$t_{ZH}$	$C_L = 100pF$ , SW = GND, ( <a href="#">Figure 3</a> , <a href="#">Note 10</a> )	Full	250	1000	2000	ns	
Driver Enable to Output Low	$t_{ZL}$	$C_L = 100pF$ , SW = $V_{CC}$ , ( <a href="#">Figure 3</a> , <a href="#">Note 10</a> )	Full	250	860	2000	ns	
Driver Disable from Output High	$t_{HZ}$	$C_L = 15pF$ , SW = GND, ( <a href="#">Figure 3</a> )	Full	300	660	3000	ns	
Driver Disable from Output Low	$t_{LZ}$	$C_L = 15pF$ , SW = $V_{CC}$ , ( <a href="#">Figure 3</a> )	Full	300	640	3000	ns	
Receiver Input to Output Delay	$t_{PLH}$ , $t_{PHL}$	( <a href="#">Figure 4</a> )	Full	250	500	2000	ns	
Receiver Skew   $t_{PLH} - t_{PHL}$	$t_{SKD}$	( <a href="#">Figure 4</a> )	25	-	60	-	ns	
Receiver Enable to Output High	$t_{ZH}$	$C_L = 15pF$ , SW = GND, ( <a href="#">Figure 5</a> , <a href="#">Note 11</a> )	Full	-	10	50	ns	
Receiver Enable to Output Low	$t_{ZL}$	$C_L = 15pF$ , SW = $V_{CC}$ , ( <a href="#">Figure 5</a> , <a href="#">Note 11</a> )	Full	-	10	50	ns	
Receiver Disable from Output High	$t_{HZ}$	$C_L = 15pF$ , SW = GND, ( <a href="#">Figure 5</a> )	Full	-	10	50	ns	
Receiver Disable from Output Low	$t_{LZ}$	$C_L = 15pF$ , SW = $V_{CC}$ , ( <a href="#">Figure 5</a> )	Full	-	10	50	ns	
Maximum Data Rate	$f_{MAX}$		Full	250	-	-	kbps	
Time to Shutdown	$t_{SHDN}$	( <a href="#">Note 12</a> )	Full	50	120	600	ns	
Driver Enable from Shutdown to Output High	$t_{ZH}(SHDN)$	$C_L = 100pF$ , SW = GND, ( <a href="#">Figure 3</a> , <a href="#">Notes 12</a> and <a href="#">13</a> )	Full	-	1000	2000	ns	
Driver Enable from Shutdown to Output Low	$t_{ZL}(SHDN)$	$C_L = 100pF$ , SW = $V_{CC}$ , ( <a href="#">Figure 3</a> , <a href="#">Notes 12</a> and <a href="#">13</a> )	Full	-	1000	2000	ns	

## Electrical Specifications

Test Conditions:  $V_{CC} = 4.5V$  to  $5.5V$ ; Unless Otherwise Specified. Typical values are at  $V_{CC} = 5V$ ,  $T_A = +25^\circ C$ , [Note 7 \(Continued\)](#)

PARAMETER	SYMBOL	TEST CONDITIONS	TEMP (°C)	MIN	TYP	MAX	UNIT
Receiver Enable from Shutdown to Output High	$t_{ZH}(SHDN)$	$C_L = 15pF$ , SW = GND, ( <a href="#">Figure 5</a> , <a href="#">Notes 12</a> and <a href="#">14</a> )	Full	-	800	2500	ns
Receiver Enable from Shutdown to Output Low	$t_{ZL}(SHDN)$	$C_L = 15pF$ , SW = $V_{CC}$ , ( <a href="#">Figure 5</a> , <a href="#">Notes 12</a> and <a href="#">14</a> )	Full	-	800	2500	ns
<b>SWITCHING CHARACTERISTICS (ISL81487L)</b>							
Driver Input to Output Delay	$t_{PLH}$ , $t_{PHL}$	$R_{DIFF} = 54\Omega$ , $C_L = 100pF$ , ( <a href="#">Figure 2</a> )	Full	150	650	1200	ns
Driver Output Skew	$t_{SKEW}$	$R_{DIFF} = 54\Omega$ , $C_L = 100pF$ , ( <a href="#">Figure 2</a> )	Full	-	160	600	ns
Driver Differential Rise or Fall Time	$t_R$ , $t_F$	$R_{DIFF} = 54\Omega$ , $C_L = 100pF$ , ( <a href="#">Figure 2</a> )	Full	250	900	1200	ns
Driver Enable to Output High	$t_{ZH}$	$C_L = 100pF$ , SW = GND, ( <a href="#">Figure 3</a> , <a href="#">Note 10</a> )	Full	100	1000	1500	ns
Driver Enable to Output Low	$t_{ZL}$	$C_L = 100pF$ , SW = $V_{CC}$ , ( <a href="#">Figure 3</a> , <a href="#">Note 10</a> )	Full	100	1000	1500	ns
Driver Disable from Output High	$t_{HZ}$	$C_L = 15pF$ , SW = GND, ( <a href="#">Figure 3</a> )	Full	150	750	1500	ns
Driver Disable from Output Low	$t_{LZ}$	$C_L = 15pF$ , SW = $V_{CC}$ , ( <a href="#">Figure 3</a> )	Full	150	750	1500	ns
Receiver Input to Output Delay	$t_{PLH}$ , $t_{PHL}$	( <a href="#">Figure 4</a> )	Full	30	175	250	ns
Receiver Skew   $t_{PLH} - t_{PHL}$	$t_{SKD}$	( <a href="#">Figure 4</a> )	25	-	13	-	ns
Receiver Enable to Output High	$t_{ZH}$	$C_L = 15pF$ , SW = GND, ( <a href="#">Figure 5</a> , <a href="#">Note 11</a> )	Full	-	10	50	ns
Receiver Enable to Output Low	$t_{ZL}$	$C_L = 15pF$ , SW = $V_{CC}$ , ( <a href="#">Figure 5</a> , <a href="#">Note 11</a> )	Full	-	10	50	ns
Receiver Disable from Output High	$t_{HZ}$	$C_L = 15pF$ , SW = GND, ( <a href="#">Figure 5</a> )	Full	-	10	50	ns
Receiver Disable from Output Low	$t_{LZ}$	$C_L = 15pF$ , SW = $V_{CC}$ , ( <a href="#">Figure 5</a> )	Full	-	10	50	ns
Maximum Data Rate	$f_{MAX}$		Full	250	-	-	kbps
Time to Shutdown	$t_{SHDN}$	( <a href="#">Note 12</a> )	Full	50	140	600	ns
Driver Enable from Shutdown to Output High	$t_{ZH}(SHDN)$	$C_L = 100pF$ , SW = GND, ( <a href="#">Figure 3</a> , <a href="#">Notes 12</a> and <a href="#">13</a> )	Full	-	1100	2000	ns
Driver Enable from Shutdown to Output Low	$t_{ZL}(SHDN)$	$C_L = 100pF$ , SW = $V_{CC}$ , ( <a href="#">Figure 3</a> , <a href="#">Notes 12</a> and <a href="#">13</a> )	Full	-	1000	2000	ns
Receiver Enable from Shutdown to Output High	$t_{ZH}(SHDN)$	$C_L = 15pF$ , SW = GND, ( <a href="#">Figure 3</a> , <a href="#">Notes 12</a> and <a href="#">14</a> )	Full	-	900	2000	ns
Receiver Enable from Shutdown to Output Low	$t_{ZL}(SHDN)$	$C_L = 15pF$ , SW = $V_{CC}$ , ( <a href="#">Figure 3</a> , <a href="#">Notes 12</a> and <a href="#">14</a> )	Full	-	900	2000	ns
<b>ESD PERFORMANCE</b>							
RS-485 Pins (A/Y, B/Z)		Human Body Model	25	-	$\pm 15$	-	kV
All Other Pins			25	-	$>\pm 7$	-	kV

## NOTES:

- Currents into device pins are positive; currents out of device pins are negative. Voltages are referenced to ground unless otherwise specified.
- Supply current specification is valid for loaded drivers when DE = 0V.
- Applies to peak current. See "[Typical Performance Curves](#)" for more information.
- When testing the ISL8487E and ISL81487L, keep  $\overline{RE} = 0$  to prevent the device from entering shutdown (SHDN).
- When testing the ISL8487E and ISL81487L, the  $\overline{RE}$  signal high time must be short enough (typically <200ns) to prevent the device from entering SHDN.
- The ISL8487E and ISL81487L go into SHDN by bringing  $\overline{RE}$  high and DE low. If the inputs are in this state for less than 50ns, the parts are specified not to enter SHDN. If the inputs are in this state for at least 600ns, the parts are specified to enter SHDN. See "[Low Power Shutdown Mode \(Excluding ISL81487E\)](#)" for more information.
- Keep  $\overline{RE} = V_{CC}$  and set the DE signal low time >600ns to ensure that the device enters SHDN.
- Set the  $\overline{RE}$  signal high time >600ns to ensure that the device enters SHDN.
- Devices meeting these limits are denoted as 1/8 unit load (1/8 UL) transceivers. The RS-485 standard allows up to 32 UL on the bus, so there can be 256 1/8 UL devices on a bus.

**Test Circuits and Waveforms**

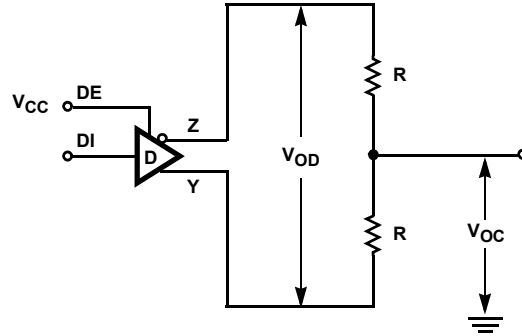

FIGURE 1. DRIVER  $V_{OD}$  AND  $V_{OC}$

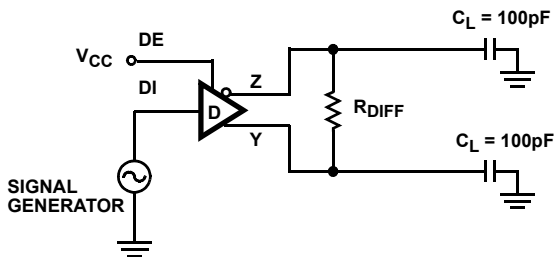
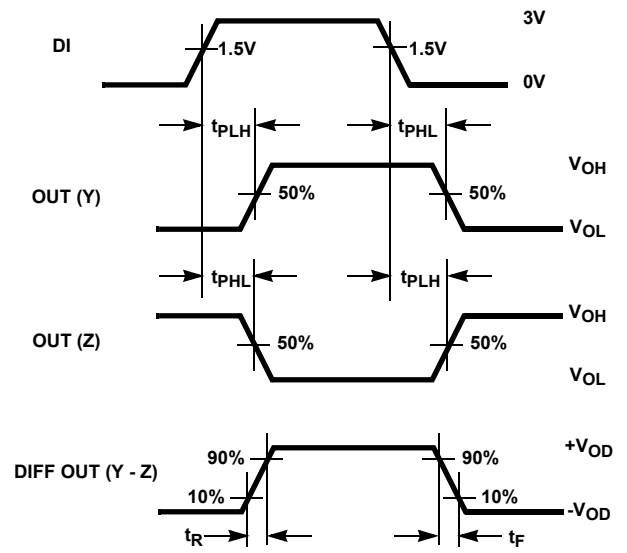

FIGURE 2A. TEST CIRCUIT



$$\text{SKEW} = |t_{PLH}(Y \text{ or } Z) - t_{PHL}(Z \text{ or } Y)|$$

FIGURE 2B. MEASUREMENT POINTS

FIGURE 2. DRIVER PROPAGATION DELAY AND DIFFERENTIAL TRANSITION TIMES

**Test Circuits and Waveforms** (Continued)

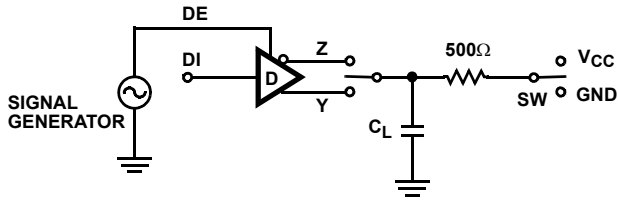

(SHDN) for ISL8487E and ISL81487L only.

PARAMETER	OUTPUT	RE	DI	SW	CL (pF)
$t_{HZ}$	Y/Z	X	1/0	GND	15
$t_{LZ}$	Y/Z	X	0/1	V <sub>CC</sub>	15
$t_{ZH}$	Y/Z	0 (Note 10)	1/0	GND	100
$t_{ZL}$	Y/Z	0 (Note 10)	0/1	V <sub>CC</sub>	100
$t_{ZH(SHDN)}$	Y/Z	1 (Note 12)	1/0	GND	100
$t_{ZL(SHDN)}$	Y/Z	1 (Note 12)	0/1	V <sub>CC</sub>	100

FIGURE 3A. TEST CIRCUIT

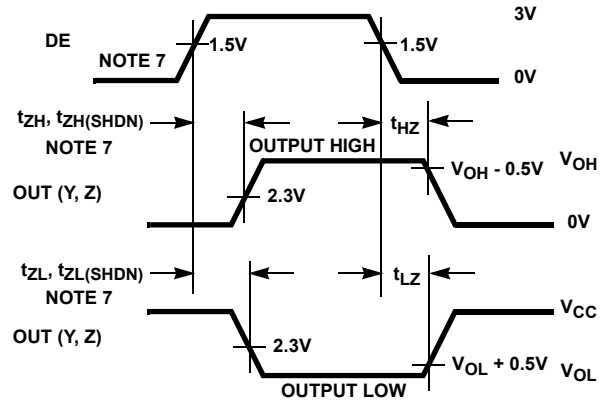

FIGURE 3B. MEASUREMENT POINTS

FIGURE 3. DRIVER ENABLE AND DISABLE TIMES

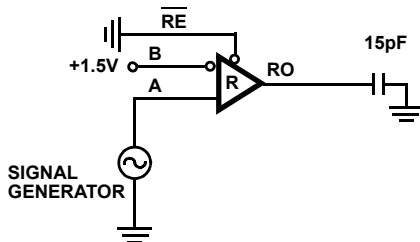

FIGURE 4A. TEST CIRCUIT

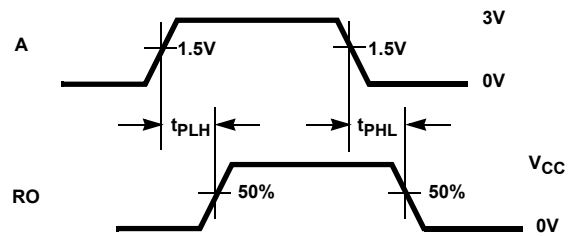
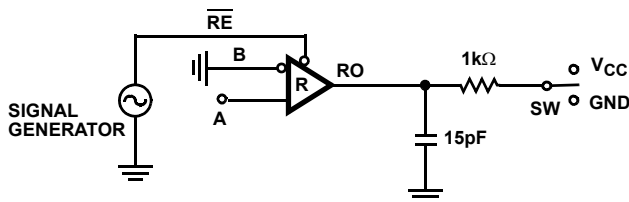

FIGURE 4B. MEASUREMENT POINTS

FIGURE 4. RECEIVER PROPAGATION DELAY



(SHDN) for ISL8487E and ISL81487L only.

PARAMETER	DE	A	SW
$t_{HZ}$	0	+1.5V	GND
$t_{LZ}$	0	-1.5V	V <sub>CC</sub>
$t_{ZH}$ (Note 11)	0	+1.5V	GND
$t_{ZL}$ (Note 11)	0	-1.5V	V <sub>CC</sub>
$t_{ZH(SHDN)}$ (Note 12)	0	+1.5V	GND
$t_{ZL(SHDN)}$ (Note 12)	0	-1.5V	V <sub>CC</sub>

FIGURE 5A. TEST CIRCUIT

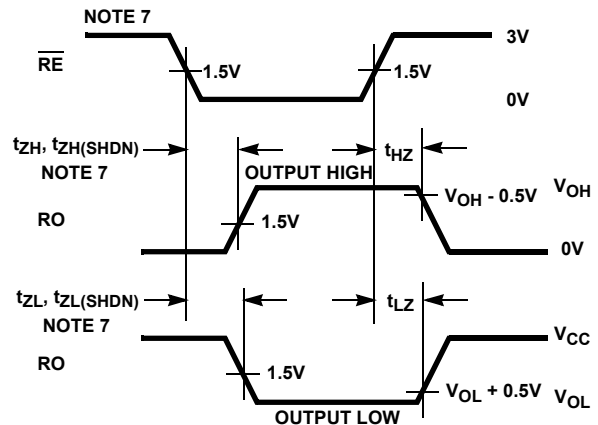

FIGURE 5B. MEASUREMENT POINTS

FIGURE 5. RECEIVER ENABLE AND DISABLE TIMES

## Application Information

RS-485 and RS-422 are differential (balanced) data transmission standards for use in long haul or noisy environments. RS-422 is a subset of RS-485, so RS-485 transceivers are also RS-422 compliant. RS-422 is a point-to-multipoint (multidrop) standard that allows only one driver and up to 10 receivers on each bus (assuming one unit load devices). RS-485 is a true multipoint standard that allows up to 32 one unit load devices (any combination of drivers and receivers) on each bus. To allow for multipoint operation, the RS-485 specification requires that drivers handle bus contention without sustaining any damage.

An important advantage of RS-485 is the extended Common-Mode Range (CMR), which specifies that the driver outputs and receiver inputs withstand signals ranging from +12V to -7V. RS-422 and RS-485 are intended for runs as long as 4000ft, so the wide CMR is necessary to handle ground potential differences and voltages induced in the cable by external fields.

### Receiver Features

These devices use a differential input receiver for maximum noise immunity and common-mode rejection. Input sensitivity is  $\pm 200\text{mV}$ , as required by the RS-422 and RS-485 specifications.

The receiver input resistance of  $96\text{k}\Omega$  surpasses the RS-422 specification of  $4\text{k}\Omega$  and is eight times the RS-485 Unit Load (UL) requirement of  $12\text{k}\Omega$  minimum. Thus, these products are known as one-eighth UL transceivers. A network can host up to 256 of these devices still complying with the RS-485 loading specification.

The receiver inputs function with common-mode voltages as great as  $\pm 7\text{V}$  outside the power supplies (that is, +12V and -7V), making them ideal for long networks in which induced voltages are a realistic concern.

All the receivers include a “fail-safe if open” function that guarantees a high level receiver output if the receiver inputs are unconnected (floating).

Receivers easily meet the data rates supported by the corresponding driver. The receiver outputs are three-statable using the active low  $\overline{\text{RE}}$  input.

### Driver Features

The RS-485/422 driver is a differential output device that delivers at least 1.5V across a  $54\Omega$  load (RS-485) and at least 2V across a  $100\Omega$  load (RS-422). The drivers feature low propagation delay skew to maximize bit width and to minimize EMI.

Driver outputs are three-statable using the active high DE input.

The ISL8487E and ISL81487L driver outputs are slew rate limited to minimize EMI and to minimize reflections in unterminated or improperly terminated networks. The

maximum data rate on these slew rate limited versions is 250kbps. The ISL81487E drivers are not limited, so faster output transition times allow data rates of at least 5Mbps.

### Data Rate, Cables, and Terminations

RS-485/422 are intended for network lengths up to 4000ft, but the maximum system data rate decreases as the transmission length increases. Devices operating at 5Mbps are limited to lengths less than a few hundred feet, while the 250kbps versions can operate at full data rates with lengths in excess of 1000ft.

Twisted pair cable is the cable of choice for RS-485/422 networks. Twisted pair cables tend to pick up noise and other electromagnetically induced voltages as common-mode signals that are effectively rejected by the differential receivers in these ICs.

Proper termination is imperative to minimize reflections when using the 5Mbps device. Short networks using the 250kbps versions do not need to be terminated, but terminations are recommended unless power dissipation is an overriding concern.

In point-to-point or point-to-multipoint (single driver on bus) networks, terminate the main cable in its characteristic impedance (typically  $120\Omega$ ) at the end farthest from the driver. In multi-receiver applications, keep stubs connecting receivers to the main cable as short as possible. In multipoint (multi-driver) systems, terminate the main cable in its characteristic impedance at both ends. Keep stubs connecting a transceiver to the main cable as short as possible.

### Built-In Driver Overload Protection

The RS-485 specification requires that drivers survive worst case bus contentions undamaged. These devices meet this requirement with driver output short-circuit current limits and on-chip thermal shutdown circuitry.

The driver output stages incorporate short-circuit current limiting circuitry that ensures the output current never exceeds the RS-485 specification, even at the common-mode voltage range extremes. These devices also use a foldback circuit that reduces the short-circuit current and as a result, the power dissipation when the contending voltage exceeds either supply.

In the event of a major short-circuit condition, the thermal shutdown feature disables the drivers when the die temperature becomes excessive. This eliminates the power dissipation, allowing the die to cool. The drivers automatically re-enable after the die temperature drops about  $15^{\circ}\text{C}$ . If the condition persists, the thermal shutdown/re-enable cycle repeats until the fault is cleared. Receivers stay operational during thermal shutdown.

**Low Power Shutdown Mode (Excluding ISL81487E)**

These CMOS transceivers all use a fraction of the power required by their bipolar counterparts, but the ISL8487E and ISL81487L include a shutdown feature that reduces the already low quiescent  $I_{CC}$  to a 500nA trickle. They enter shutdown whenever the receiver and driver are simultaneously disabled ( $\overline{RE} = V_{CC}$  and  $DE = GND$ ) for a period of at least 600ns. Disabling both the driver and the receiver for less than 50ns guarantees that shutdown is not entered.

Note that receiver and driver enable times increase when enabling from shutdown. Refer to [Note 10](#) through [14](#) at the end of the “[Electrical Specifications](#)” table for more information.

**ESD Protection**

All pins on the interface devices include Class 3 Human Body Model (HBM) ESD protection structures, but the RS-485 pins (driver outputs and receiver inputs) incorporate advanced structures allowing them to survive ESD events in excess of  $\pm 15kV$  HBM. The RS-485 pins are particularly vulnerable to

ESD damage because they typically connect to an exposed port on the exterior of the finished product. Touching the port pins or connecting a cable can cause an ESD event that destroys unprotected ICs. The ESD structures protect the device whether or not it is powered up, protect without allowing any latchup mechanism to activate, and without degrading the RS-485 common-mode range of -7V to +12V. This built-in ESD protection eliminates the need for board level protection structures (for example, transient suppression diodes), and the associated undesirable capacitive load they present.

**Human Body Model Testing**

This test method emulates the ESD event delivered to an IC during human handling. The tester delivers the charge stored on a 100pF capacitor through a 1.5k $\Omega$  current limiting resistor into the pin under test. The HBM method determines an IC’s ability to withstand the ESD events typically present during handling and manufacturing. The RS-485 pin survivability on this high ESD family has been characterized to be in excess of  $\pm 15kV$  for discharges to GND.

**Typical Performance Curves**

$V_{CC} = 5V, T_A = +25^\circ C, ISL8487E, ISL81487L, \text{ and } ISL81487E; \text{ unless otherwise specified}$

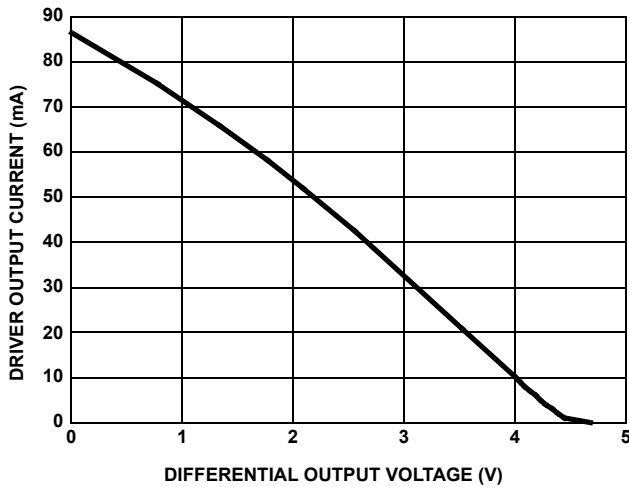

FIGURE 6. DRIVER OUTPUT CURRENT vs DIFFERENTIAL OUTPUT VOLTAGE

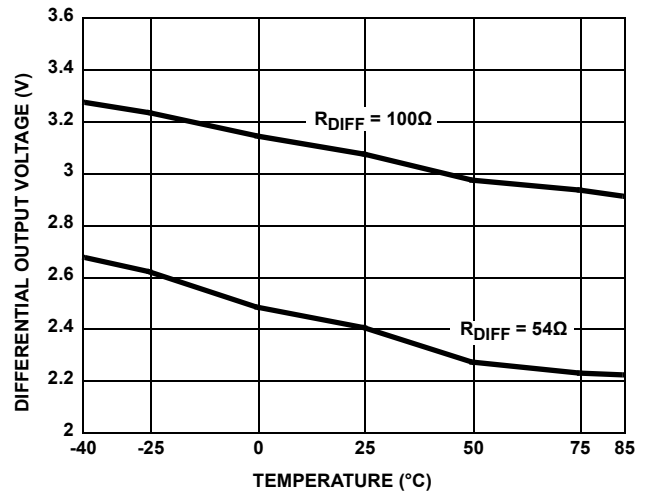

FIGURE 7. DRIVER DIFFERENTIAL OUTPUT VOLTAGE vs TEMPERATURE

**Typical Performance Curves**

$V_{CC} = 5V$ ,  $T_A = +25^{\circ}C$ , ISL8487E, ISL81487L, and ISL81487E; unless otherwise specified

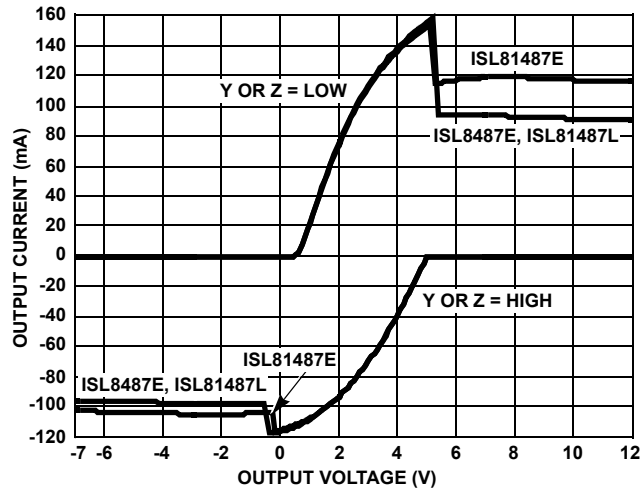

FIGURE 8. DRIVER OUTPUT CURRENT vs SHORT-CIRCUIT VOLTAGE

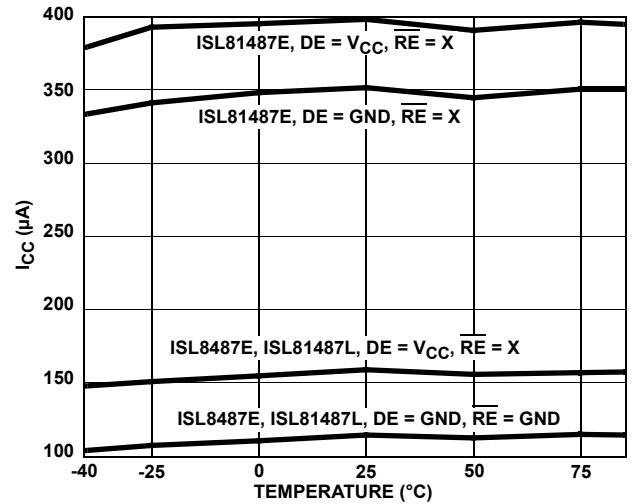

FIGURE 9. SUPPLY CURRENT vs TEMPERATURE

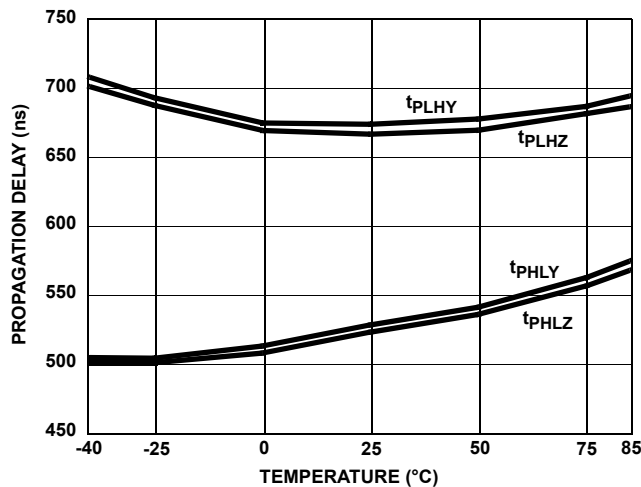

FIGURE 10. DRIVER PROPAGATION DELAY vs TEMPERATURE (ISL8487E and ISL81487L)

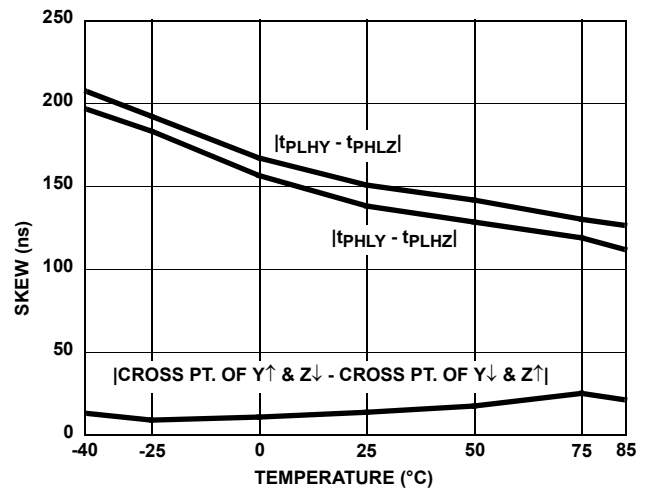

FIGURE 11. DRIVER SKEW vs TEMPERATURE (ISL8487E and ISL81487L)

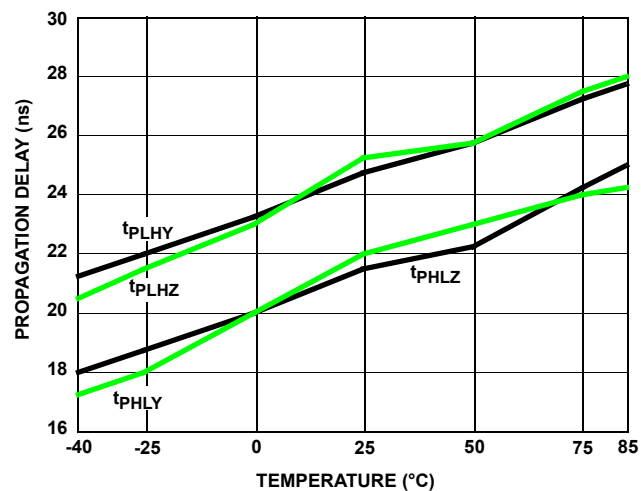

FIGURE 12. DRIVER PROPAGATION DELAY vs TEMPERATURE (ISL81487E)

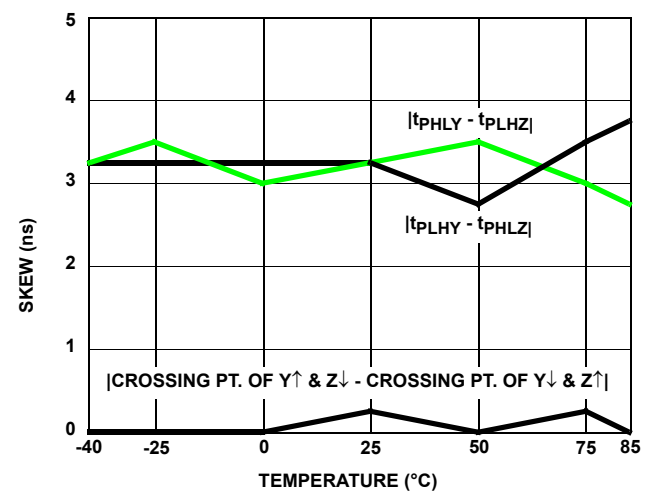

FIGURE 13. DRIVER SKEW vs TEMPERATURE (ISL81487E)

**Typical Performance Curves**  $V_{CC} = 5V$ ,  $T_A = +25^\circ C$ , ISL8487E, ISL81487L, and ISL81487E; unless otherwise specified

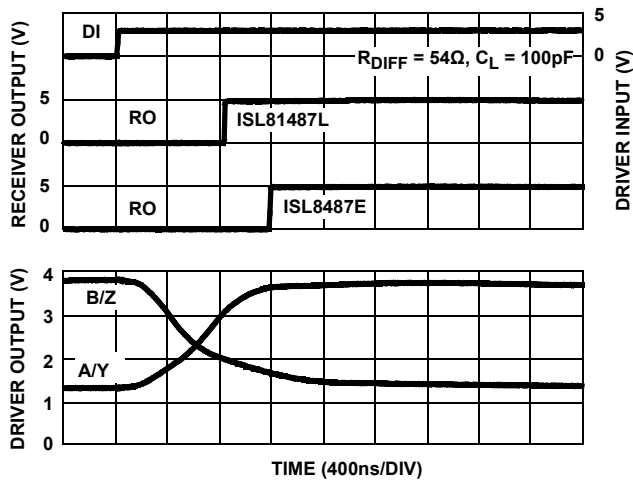

FIGURE 14. DRIVER AND RECEIVER WAVEFORMS, LOW TO HIGH (ISL8487E and ISL81487L)

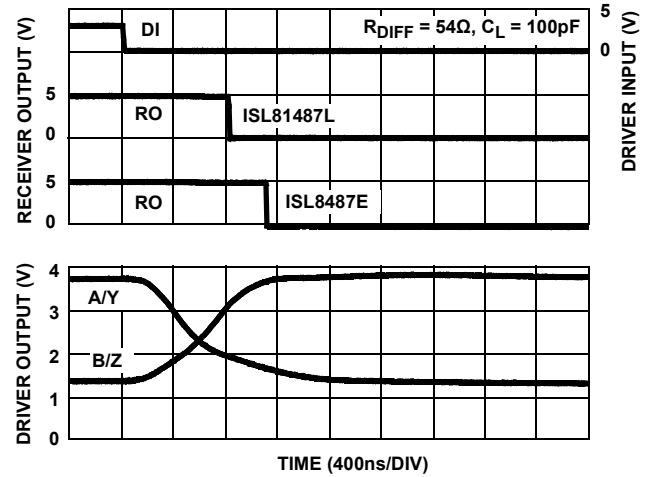

FIGURE 15. DRIVER AND RECEIVER WAVEFORMS, HIGH TO LOW (ISL8487E and ISL81487L)

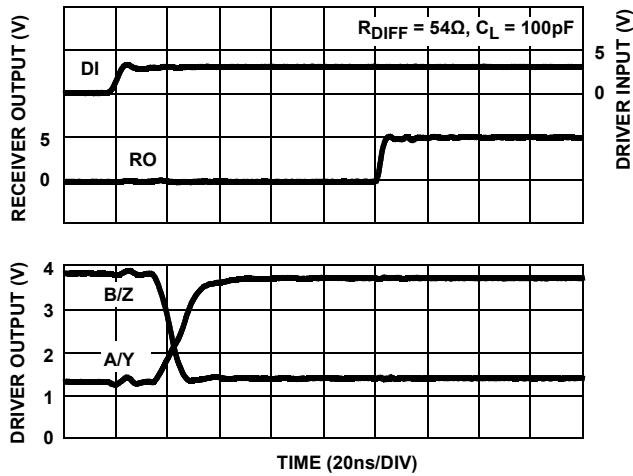

FIGURE 16. DRIVER AND RECEIVER WAVEFORMS, LOW TO HIGH (ISL81487E)

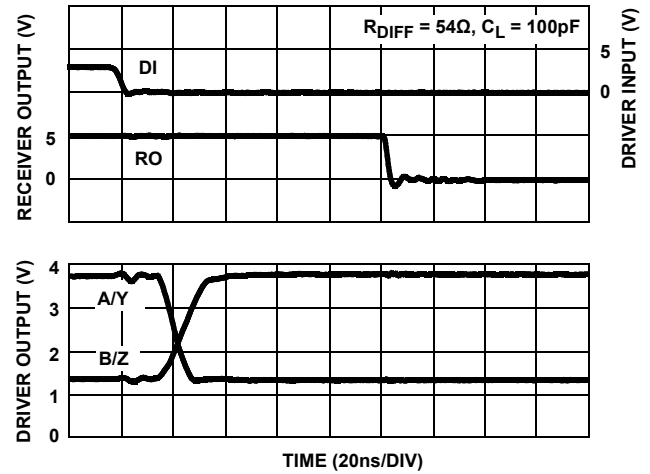

FIGURE 17. DRIVER AND RECEIVER WAVEFORMS, HIGH TO LOW (ISL81487E)

**Die Characteristics**

SUBSTRATE POTENTIAL (POWERED UP):

GND

TRANSISTOR COUNT:

518

PROCESS:

Si Gate CMOS

**Revision History** The revision history provided is for informational purposes only and is believed to be accurate, but not warranted. Please visit our website to make sure you have the latest revision.

DATE	REVISION	CHANGE
Sep 20, 2018	FN6051.8	Applied Renesas Header/Footer. Added Related Literature section. Updated Ordering Information table by removing retired parts ISL8487EIB, ISL81487LIB, ISL81487LIP, and ISL81487EIP, adding Notes 1 and 3, and adding tape and reel parts and column. Updated the Typical Operating Circuit diagram on page 2. Added Revision History section. Updated POD M8.15 to the latest revision. Changes are as follows: -Revision 1: Initial revision -Revision 1 to revision 2: Updated to new package outline drawing format by removing table, moving dimensions onto drawing, and adding land pattern -Revision 2 to revision 3: Changed the following values in Typical Recommended Landing Pattern: 2.41(0.095) to 2.20 (0.087) 0.76(0.030) to 0.60(0.023) 0.200 to 5.20(0.205) -Revision 3 to revision 4: Changed text in Note 1 from "1982" to "1994"

**Package Outline Drawings**

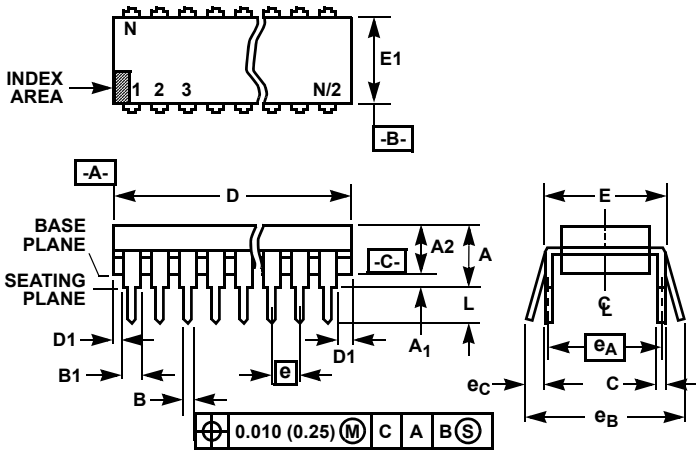

**NOTES:**

- Controlling Dimensions: INCH. In case of conflict between English and Metric dimensions, the inch dimensions control.
- Dimensioning and tolerancing per ANSI Y14.5M-1982.
- Symbols are defined in the "MO Series Symbol List" in Section 2.2 of Publication No. 95.
- Dimensions A, A1 and L are measured with the package seated in JEDEC seating plane gauge GS-3.
- D, D1, and E1 dimensions do not include mold flash or protrusions. Mold flash or protrusions shall not exceed 0.010 inch (0.25mm).
- E and  $e_A$  are measured with the leads constrained to be perpendicular to datum  $-C-$ .
- $e_B$  and  $e_C$  are measured at the lead tips with the leads unconstrained.  $e_C$  must be zero or greater.
- B1 maximum dimensions do not include dambar protrusions. Dambar protrusions shall not exceed 0.010 inch (0.25mm).
- N is the maximum number of terminal positions.
- Corner leads (1, N, N/2 and N/2 + 1) for E8.3, E16.3, E18.3, E28.3, E42.6 will have a B1 dimension of 0.030 - 0.045 inch (0.76 - 1.14mm).

**E8.3 (JEDEC MS-001-BA ISSUE D)  
8 LEAD DUAL-IN-LINE PLASTIC PACKAGE**

SYMBOL	INCHES		MILLIMETERS		NOTES
	MIN	MAX	MIN	MAX	
A	-	0.210	-	5.33	4
A1	0.015	-	0.39	-	4
A2	0.115	0.195	2.93	4.95	-
B	0.014	0.022	0.356	0.558	-
B1	0.045	0.070	1.15	1.77	8, 10
C	0.008	0.014	0.204	0.355	-
D	0.355	0.400	9.01	10.16	5
D1	0.005	-	0.13	-	5
E	0.300	0.325	7.62	8.25	6
E1	0.240	0.280	6.10	7.11	5
e	0.100 BSC		2.54 BSC		-
$e_A$	0.300 BSC		7.62 BSC		6
$e_B$	-	0.430	-	10.92	7
L	0.115	0.150	2.93	3.81	4
N	8		8		9

Rev. 0 12/93

For the most recent package outline drawing, see [E8.3](#).

**M8.15**  
**8 LEAD NARROW BODY SMALL OUTLINE PLASTIC PACKAGE**  
 Rev 4, 1/12

For the most recent package outline drawing, see [M8.15](#).

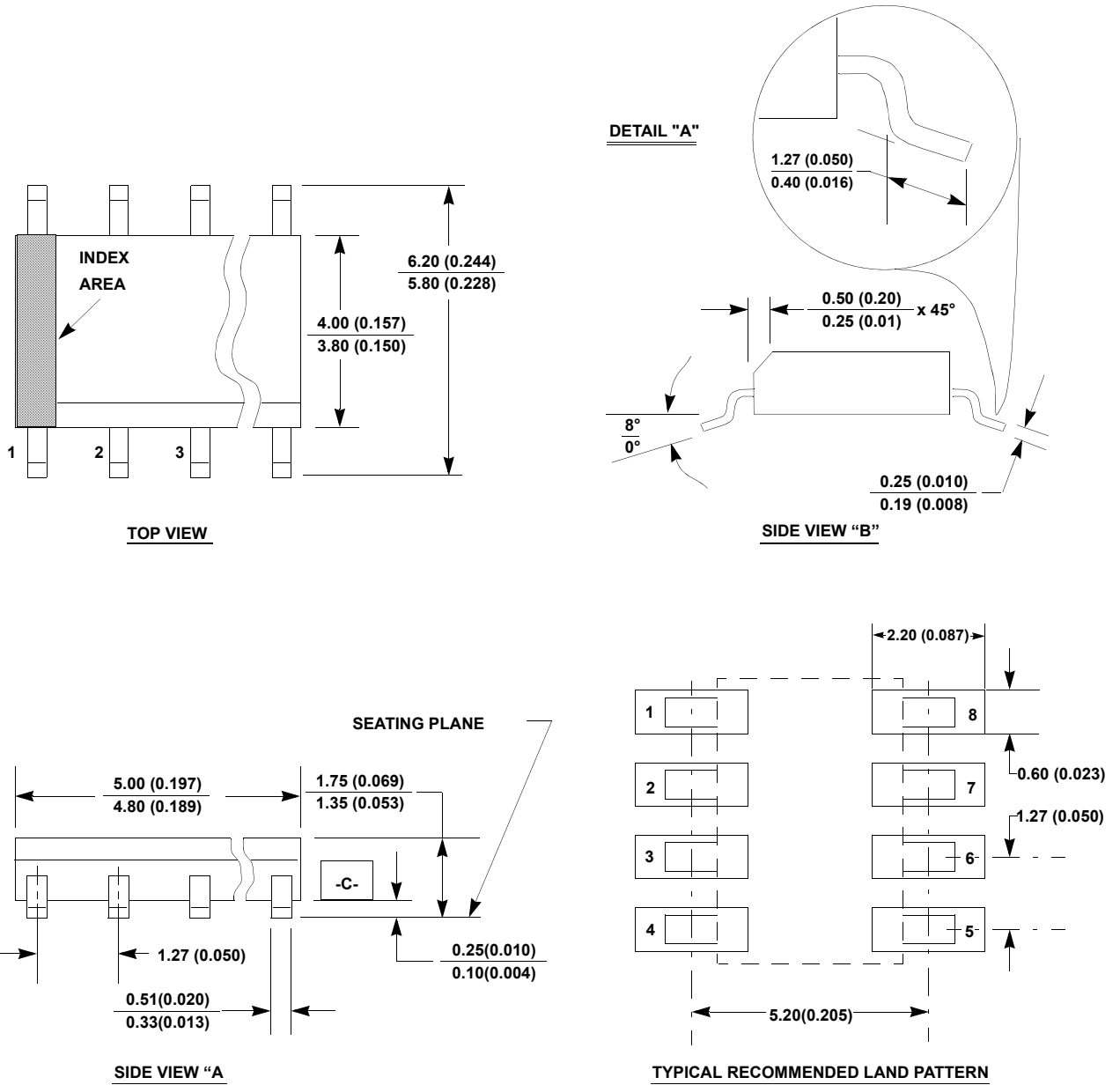

- NOTES:**
1. Dimensioning and tolerancing per ANSI Y14.5M-1994.
  2. Package length does not include mold flash, protrusions or gate burrs. Mold flash, protrusion and gate burrs shall not exceed 0.15mm (0.006 inch) per side.
  3. Package width does not include interlead flash or protrusions. Interlead flash and protrusions shall not exceed 0.25mm (0.010 inch) per side.
  4. The chamfer on the body is optional. If it is not present, a visual index feature must be located within the crosshatched area.
  5. Terminal numbers are shown for reference only.
  6. The lead width as measured 0.36mm (0.014 inch) or greater above the seating plane, shall not exceed a maximum value of 0.61mm (0.024 inch).
  7. Controlling dimension: MILLIMETER. Converted inch dimensions are not necessarily exact.
  8. This outline conforms to JEDEC publication MS-012-AA ISSUE C.

## Notice

1. Descriptions of circuits, software and other related information in this document are provided only to illustrate the operation of semiconductor products and application examples. You are fully responsible for the incorporation or any other use of the circuits, software, and information in the design of your product or system. Renesas Electronics disclaims any and all liability for any losses and damages incurred by you or third parties arising from the use of these circuits, software, or information.
2. Renesas Electronics hereby expressly disclaims any warranties against and liability for infringement or any other claims involving patents, copyrights, or other intellectual property rights of third parties, by or arising from the use of Renesas Electronics products or technical information described in this document, including but not limited to, the product data, drawings, charts, programs, algorithms, and application examples.
3. No license, express, implied or otherwise, is granted hereby under any patents, copyrights or other intellectual property rights of Renesas Electronics or others.
4. You shall not alter, modify, copy, or reverse engineer any Renesas Electronics product, whether in whole or in part. Renesas Electronics disclaims any and all liability for any losses or damages incurred by you or third parties arising from such alteration, modification, copying or reverse engineering.
5. Renesas Electronics products are classified according to the following two quality grades: "Standard" and "High Quality". The intended applications for each Renesas Electronics product depends on the product's quality grade, as indicated below.  
"Standard": Computers; office equipment; communications equipment; test and measurement equipment; audio and visual equipment; home electronic appliances; machine tools; personal electronic equipment; industrial robots; etc.  
"High Quality": Transportation equipment (automobiles, trains, ships, etc.); traffic control (traffic lights); large-scale communication equipment; key financial terminal systems; safety control equipment; etc.  
Unless expressly designated as a high reliability product or a product for harsh environments in a Renesas Electronics data sheet or other Renesas Electronics document, Renesas Electronics products are not intended or authorized for use in products or systems that may pose a direct threat to human life or bodily injury (artificial life support devices or systems; surgical implantations; etc.), or may cause serious property damage (space system; undersea repeaters; nuclear power control systems; aircraft control systems; key plant systems; military equipment; etc.). Renesas Electronics disclaims any and all liability for any damages or losses incurred by you or any third parties arising from the use of any Renesas Electronics product that is inconsistent with any Renesas Electronics data sheet, user's manual or other Renesas Electronics document.
6. When using Renesas Electronics products, refer to the latest product information (data sheets, user's manuals, application notes, "General Notes for Handling and Using Semiconductor Devices" in the reliability handbook, etc.), and ensure that usage conditions are within the ranges specified by Renesas Electronics with respect to maximum ratings, operating power supply voltage range, heat dissipation characteristics, installation, etc. Renesas Electronics disclaims any and all liability for any malfunctions, failure or accident arising out of the use of Renesas Electronics products outside of such specified ranges.
7. Although Renesas Electronics endeavors to improve the quality and reliability of Renesas Electronics products, semiconductor products have specific characteristics, such as the occurrence of failure at a certain rate and malfunctions under certain use conditions. Unless designated as a high reliability product or a product for harsh environments in a Renesas Electronics data sheet or other Renesas Electronics document, Renesas Electronics products are not subject to radiation resistance design. You are responsible for implementing safety measures to guard against the possibility of bodily injury, injury or damage caused by fire, and/or danger to the public in the event of a failure or malfunction of Renesas Electronics products, such as safety design for hardware and software, including but not limited to redundancy, fire control and malfunction prevention, appropriate treatment for aging degradation or any other appropriate measures. Because the evaluation of microcomputer software alone is very difficult and impractical, you are responsible for evaluating the safety of the final products or systems manufactured by you.
8. Please contact a Renesas Electronics sales office for details as to environmental matters such as the environmental compatibility of each Renesas Electronics product. You are responsible for carefully and sufficiently investigating applicable laws and regulations that regulate the inclusion or use of controlled substances, including without limitation, the EU RoHS Directive, and using Renesas Electronics products in compliance with all these applicable laws and regulations. Renesas Electronics disclaims any and all liability for damages or losses occurring as a result of your noncompliance with applicable laws and regulations.
9. Renesas Electronics products and technologies shall not be used for or incorporated into any products or systems whose manufacture, use, or sale is prohibited under any applicable domestic or foreign laws or regulations. You shall comply with any applicable export control laws and regulations promulgated and administered by the governments of any countries asserting jurisdiction over the parties or transactions.
10. It is the responsibility of the buyer or distributor of Renesas Electronics products, or any other party who distributes, disposes of, or otherwise sells or transfers the product to a third party, to notify such third party in advance of the contents and conditions set forth in this document.
11. This document shall not be reprinted, reproduced or duplicated in any form, in whole or in part, without prior written consent of Renesas Electronics.
12. Please contact a Renesas Electronics sales office if you have any questions regarding the information contained in this document or Renesas Electronics products.

(Note 1) "Renesas Electronics" as used in this document means Renesas Electronics Corporation and also includes its directly or indirectly controlled subsidiaries.

(Note 2) "Renesas Electronics product(s)" means any product developed or manufactured by or for Renesas Electronics.

(Rev.4.0-1 November 2017)



### SALES OFFICES

Renesas Electronics Corporation

<http://www.renesas.com>

Refer to "<http://www.renesas.com/>" for the latest and detailed information.

#### Renesas Electronics Corporation

TOYOSU FORESIA, 3-2-24 Toyosu, Koto-ku, Tokyo 135-0061, Japan

#### Renesas Electronics America Inc.

1001 Murphy Ranch Road, Milpitas, CA 95035, U.S.A.  
Tel: +1-408-432-8888, Fax: +1-408-434-5351

#### Renesas Electronics Canada Limited

9251 Yonge Street, Suite 8309 Richmond Hill, Ontario Canada L4C 9T3  
Tel: +1-905-237-2004

#### Renesas Electronics Europe Limited

Dukes Meadow, Millboard Road, Bourne End, Buckinghamshire, SL8 5FH, U.K  
Tel: +44-1628-651-700

#### Renesas Electronics Europe GmbH

Arcadiastrasse 10, 40472 Düsseldorf, Germany  
Tel: +49-211-6503-0, Fax: +49-211-6503-1327

#### Renesas Electronics (China) Co., Ltd.

Room 1709 Quantum Plaza, No.27 ZhichunLu, Haidian District, Beijing, 100191 P. R. China  
Tel: +86-10-8235-1155, Fax: +86-10-8235-7679

#### Renesas Electronics (Shanghai) Co., Ltd.

Unit 301, Tower A, Central Towers, 555 Langao Road, Putuo District, Shanghai, 200333 P. R. China  
Tel: +86-21-2226-0888, Fax: +86-21-2226-0999

#### Renesas Electronics Hong Kong Limited

Unit 1601-1611, 16/F., Tower 2, Grand Century Place, 193 Prince Edward Road West, Mongkok, Kowloon, Hong Kong  
Tel: +852-2265-6688, Fax: +852 2886-9022

#### Renesas Electronics Taiwan Co., Ltd.

13F, No. 363, Fu Shing North Road, Taipei 10543, Taiwan  
Tel: +886-2-8175-9600, Fax: +886 2-8175-9670

#### Renesas Electronics Singapore Pte. Ltd.

80 Bendemeer Road, Unit #06-02 Hyflux Innovation Centre, Singapore 339949  
Tel: +65-6213-0200, Fax: +65-6213-0300

#### Renesas Electronics Malaysia Sdn.Bhd.

Unit 1207, Block B, Menara Amcorp, Amcorp Trade Centre, No. 18, Jin Persiaran Barat, 46050 Petaling Jaya, Selangor Darul Ehsan, Malaysia  
Tel: +60-3-7955-9390, Fax: +60-3-7955-9510

#### Renesas Electronics India Pvt. Ltd.

No.777C, 100 Feet Road, HAL 2nd Stage, Indiranagar, Bangalore 560 038, India  
Tel: +91-80-67208700, Fax: +91-80-67208777

#### Renesas Electronics Korea Co., Ltd.

17F, KAMCO Yangjae Tower, 262, Gangnam-daero, Gangnam-gu, Seoul, 06265 Korea  
Tel: +82-2-558-3737, Fax: +82-2-558-5338

## Looking for pricing, stock, or lifecycle information?

Click below to explore more details on WIN SOURCE:

 [View ISL81487EIPZ on WIN SOURCE](#)

 [Intersil Information](#)

## Optimize Your Supply Chain with WIN SOURCE Solutions

-  Global Sourcing Solution
-  Obsolete Management
-  Cost Control Management
-  Shortage Management
-  Alternative Solution
-  Excess Inventory Management