



**THE DATASHEET OF
ISL6506BCBZ-T**



Multiple Linear Power Controller with ACPI Control Interface

The ISL6506 complements other power building blocks (voltage regulators) in ACPI-compliant designs for microprocessor and computer applications. The IC integrates the control of the 5V_{DUAL} and 3.3V_{DUAL} rails into an 8 Ld EPAD SOIC package. The ISL6506 operating mode (active outputs or sleep outputs) is selectable through two digital control pins; S3 and S5.

A completely integrated linear regulator generates the 3.3V_{DUAL} voltage plane from the ATX supply's 5V_{SB} output during sleep states (S3, S4/S5). In active states (during S0 and S1/S2), the ISL6506 uses an external N-Channel pass MOSFET to connect the outputs directly to the 3.3V input supplied by an ATX power supply, for minimal losses.

The ISL6506 powers up the 5V_{DUAL} plane by switching in the ATX 5V output through an NMOS transistor in active states, or by switching in the ATX 5V_{SB} through a PMOS (or PNP) transistor in S3 sleep state. In S4/S5 sleep states, the ISL6506 and ISL6506B 5V_{DUAL} output is shut down. In the ISL6506A, the 5V_{DUAL} output stays on during S4/S5 sleep states.

Functionally, the ISL6506 and ISL6506B are identical. The ISL6506B, however, features a 2A current limit on the internal 3.3V LDO while the ISL6506 has a 1A current limit. The ISL6506A has a 1A current limit on the internal 3.3V LDO.

Features

- Provides 2 ACPI-Controlled Voltages
 - 5V_{DUAL} USB/Keyboard/Mouse
 - 3.3V_{DUAL}/3.3V_{SB} PCI/Auxiliary/LAN
- Excellent 3.3V_{DUAL} Regulation in S3/S4/S5
 - ±2.0% Over-Temperature
 - 1A Capability on ISL6506 and ISL6506A
 - 2A Capability on ISL6506B
- Small Size; Very Low External Component Count
- Over-Temperature Shutdown
- Pb-Free Available (RoHS Compliant)

Applications

- ACPI-Compliant Power Regulation for Motherboards
 - ISL6506, ISL6506B: 5V_{DUAL} is shut down in S4/S5 sleep states
 - ISL6506A: 5V_{DUAL} stays on in S4/S5 sleep states

Pinout

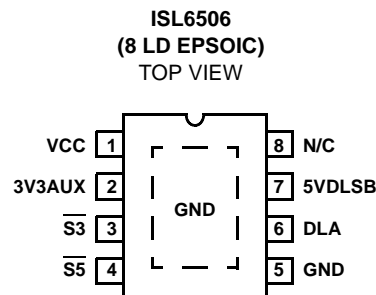

Ordering Information

PART NUMBER	PART MARKING	TEMP. RANGE (°C)	PACKAGE	PKG. DWG. #
ISL6506CB*	ISL 6506CB	0 to +70	8 Ld EPSONIC	M8.15C
ISL6506CBZ* (Note)	6506 CBZ	0 to +70	8 Ld EPSONIC (Pb-free)	M8.15C
ISL6506ACB*	6506 ACB	0 to +70	8 Ld EPSONIC	M8.15C
ISL6506ACBZ* (Note)	6506 ACBZ	0 to +70	8 Ld EPSONIC (Pb-free)	M8.15C
ISL6506BCB*	6506 BCB	0 to +70	8 Ld EPSONIC	M8.15C
ISL6506BCBZ* (Note)	6506 BCBZ	0 to +70	8 Ld EPSONIC (Pb-free)	M8.15C
ISL6506BCBZA* (Note)	6506 BCBZ	0 to +70	8 Ld EPSONIC (Pb-free)	M8.15C

*Add "-T" suffix for tape and reel. Please refer to TB347 for details on reel specifications.

NOTE: These Intersil Pb-free plastic packaged products employ special Pb-free material sets; molding compounds/die attach materials and 100% matte tin plate PLUS ANNEAL - e3 termination finish, which is RoHS compliant and compatible with both SnPb and Pb-free soldering operations. Intersil Pb-free products are MSL classified at Pb-free peak reflow temperatures that meet or exceed the Pb-free requirements of IPC/JEDEC J STD-020.

Block Diagram

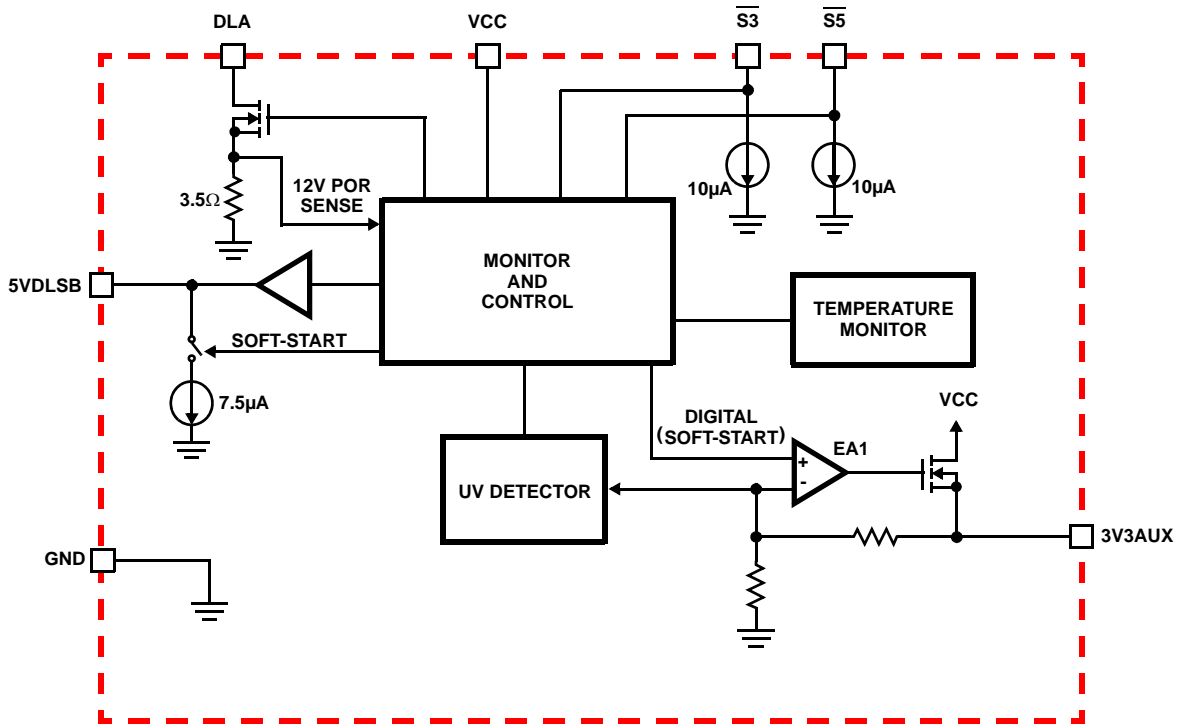

Typical Application

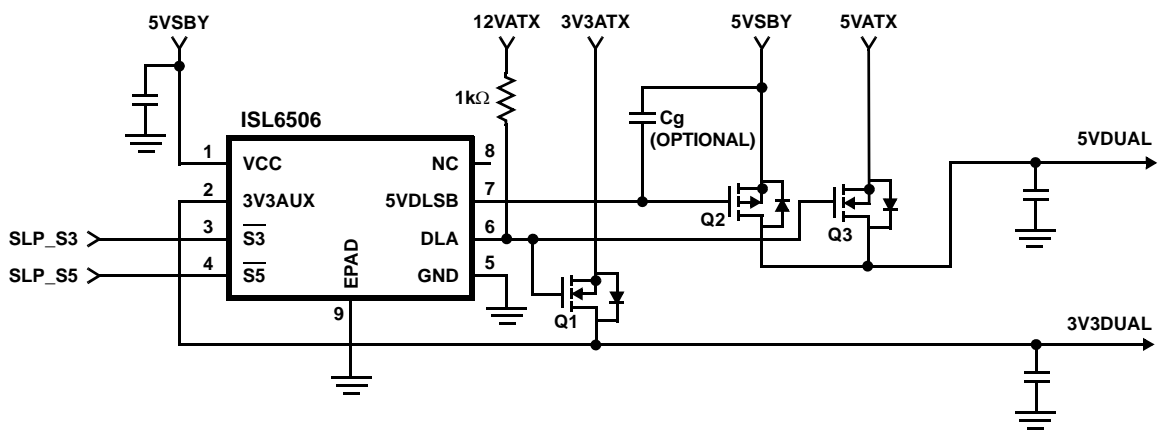

ISL6506, ISL6506A, ISL6506B

Absolute Maximum Ratings

Supply Voltage, V_{5VSB}	+7.0V
DLA	GND - 0.3V to +14.5V
All Other Pins	+7.0V
ESD Rating	
Human Body Model	4000V

Thermal Information

Thermal Resistance (Typical)	θ_{JA} (°C/W)	θ_{JC} (°C/W)
EPSON Package (Notes 1, 2)	40	3.5
Maximum Junction Temperature (Plastic Package)	+150°C	
Maximum Storage Temperature Range	-65°C to +150°C	
Pb-free reflow profile	see link below	
http://www.intersil.com/pbfree/Pb-FreeReflow.asp		

Recommended Operating Conditions

Supply Voltage, V_{5VSB}	+5V ±5%
Lowest 5VSB Supply Voltage Guaranteeing Parameters	+4.5V
Digital Inputs, $\overline{V_{Sx}}$	0 to +5.5V
Ambient Temperature Range	0°C to +70°C
Junction Temperature Range	0°C to +125°C

CAUTION: Do not operate at or near the maximum ratings listed for extended periods of time. Exposure to such conditions may adversely impact product reliability and result in failures not covered by warranty.

NOTES:

- θ_{JA} is measured in free air with the component mounted on a high effective thermal conductivity test board with “direct attach” features.
- For θ_{JC} , the “case temp” location is the center of the exposed metal pad on the package underside.
- Limits should be considered typical and are not production tested.

Electrical Specifications Recommended Operating Conditions; Parameters with MIN and/or MAX limits are 100% tested at +25°C, unless otherwise specified. Temperature limits established by characterization and are not production tested.

PARAMETER	SYMBOL	TEST CONDITIONS	MIN	TYP	MAX	UNITS
VCC SUPPLY CURRENT						
Nominal Supply Current	I_{5VSB}	$\overline{V_{S3}} = 5V, \overline{V_{S5}} = 5V$ (S0 State)	-	3.60	-	mA
		$\overline{V_{S3}} = 0V, \overline{V_{S5}} = 5V$ (S3 State)	-	4.60	-	mA
		$\overline{V_{S5}} = 0V$ (S5 State)	-	4.60	-	mA
POWER-ON RESET						
Rising 5VSB POR Threshold			-	-	4.5	V
Falling 5VSB POR Threshold			3.60	-	3.95	V
Rising 12V POR Threshold		1.00k Ω resistor between DLA and 12V Rail	8.9	9.8	10.8	V
3.3V_{AUX} LINEAR REGULATOR						
Regulation		$V_{5VSBY} = 5.0V, I_{3V3SB} = 0A$	-	-	2.0	%
3V3SB Nominal Voltage Level	V_{3V3SB}		-	3.3	-	V
3V3SB Undervoltage Threshold	V_{3V3SB_UV}		-	2.475	-	V
3V3SB Overcurrent Trip	I_{3V3SB_TRIP}	ISL6506, ISL6506A (Note 3)	-	-	1	A
		ISL6506B (Note 3)	-	-	2	A
5V_{DUAL} SWITCH CONTROLLER						
5VDLSB Output Drive Current	I_{5VDLSB}	$V_{5VDLSB} = 4V, V_{5VSB} = 5V$	20	-	35	mA
TIMING INTERVAL						
S0 to S3 Transition Delay			-	58	-	μs
SOFT-START						
Soft-start Interval	t_{SS}		6.55	8.2	9.85	ms
5VDLSB Soft-start Current Source			-	-7.5	-	μA
CONTROL I/O ($\overline{S3}, \overline{S5}$)						
High Level Input Threshold			-	-	2.2	V
Low Level Input Threshold			0.8	-	-	V
$\overline{S3}, \overline{S5}$ Internal Pull-down Current to GND			-	10	-	μA
TEMPERATURE MONITOR						
Shutdown-Level Threshold		(Note 3)	-	140	-	°C

Functional Pin Description

VCC (Pin 1)

Provide a very well decoupled 5V bias supply for the IC to this pin by connecting it to the ATX 5V_{SB} output. This pin provides all the bias for the IC as well as the input voltage for the internal standby 3V3AUX LDO. The voltage at this pin is monitored for power-on reset (POR) purposes.

GND (Pin 5, Pad)

Signal ground for the IC. These pins are also the ground return for the internal 3V3AUX LDO that is active in S3/S4/S5 sleep states. All voltage levels are measured with respect to these pins.

S3 and S5 (Pins 3 and 4)

These pins switch the IC's operating state from active (S0, S1/S2) to S3 and S4/S5 sleep states. These are digital inputs featuring internal 10µA pull-down current sources on each pin. Additional circuitry blocks illegal state transitions, such as S4/S5 to S3. Connect S3 and S5 to the computer system's SLP_S3 and SLP_S5 signals, respectively.

3V3AUX (Pin 2)

Connect this pin to the 3V3DUAL output. In sleep states, the voltage at this pin is regulated to 3.3V through an internal pass device powered from 5V_{SBY} through the VCC pin. In active states, ATX 3.3V output is delivered to this node through a fully-on NMOS transistor. During S3 and S4/S5 states, this pin is monitored for undervoltage events.

DLA (Pin 6)

This pin is an open-drain output. A 1kΩ resistor must be connected from this pin to the ATX 12V output. This resistor is used to pull the gates of suitable N-MOSFETs to 12V, which in active state, switch in the ATX 3.3V and 5V outputs into the 3.3V_{AUX} and 5V_{DUAL} outputs, respectively. This pin is also used to monitor the 12V rail during POR. If a resistor other than 1kΩ is used, the POR level will be affected.

5VDLSB (Pin 7)

Connect this pin to the gate of a suitable P-MOSFET.

ISL6506 and ISL6506B: In S3 sleep state, this transistor is switched on, connecting the ATX 5V_{SB} output to the 5V_{DUAL} regulator output.

ISL6506A: In S3 and S4/S5 sleep state, this transistor is switched on, connecting the ATX 5V_{SB} output to the 5V_{DUAL} regulator output.

Description

Operation

The ISL6506 controls 2 output voltages, 3.3V_{DUAL} and 5V_{DUAL}. It is designed for microprocessor computer applications requiring 3.3V, 5V, 5V_{SB}, and 12V bias input from an ATX power supply. The IC is composed of one linear

controller/regulator supplying the computer system's 3.3V_{DUAL} power, a dual switch controller supplying the 5V_{DUAL} voltage, as well as all the control and monitoring functions necessary for complete ACPI implementation.

Initialization

The ISL6506 automatically initializes upon receipt of input power. The Power-On Reset (POR) function continually monitors the 5V_{SB} input supply voltage. The ISL6506 also monitors the 12V rail to insure that the ATX rails are up before entering into the S0 state even if both SLP_S3 and SLP_S5 are both high.

Dual Outputs Operational Truth Table

Table 1 describes the truth combinations pertaining to the 3.3V_{DUAL} and 5V_{DUAL} outputs. The internal circuitry does not allow the transition from an S4/S5 state to an S3 state.

TABLE 1. 5V_{DUAL} OUTPUT TRUTH TABLE

S5	S3	3.3AUX	5VDL	COMMENTS
1	1	3.3V	5V	S0/S1/S2 States (Active)
1	0	3.3V	5V	S3
0	1	Note		Maintains Previous State
0	0	3.3V	0V	S4/S5 (ISL6506 and ISL6506B)
0	0	3.3V	5V	S4/S5 (ISL6506A)

NOTE: Combination Not Allowed.

Functional Timing Diagrams

Figures 1 (ISL6506, ISL6506B) and 2 (ISL6506A) are simplified timing diagrams, detailing the power-up/down sequences of all the outputs in response to the status of the sleep-state pins (S3, S5), as well as the status of the input ATX supply. Not shown in these diagrams is the deglitching feature used to protect against false sleep state tripping. Additionally, the ISL6506 features a 60µs delay in transitioning from S0 to S3 states. The transition from the S0 state to S4/S5 state is immediate.

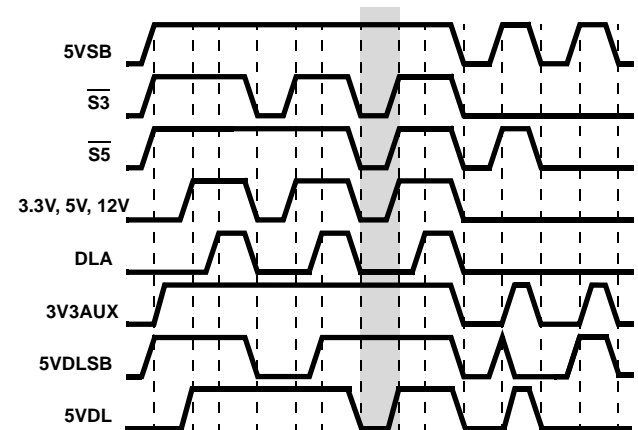

FIGURE 1. 5V_{DUAL} AND 3.3V_{AUX} TIMING DIAGRAM; ISL6506 AND ISL6506B

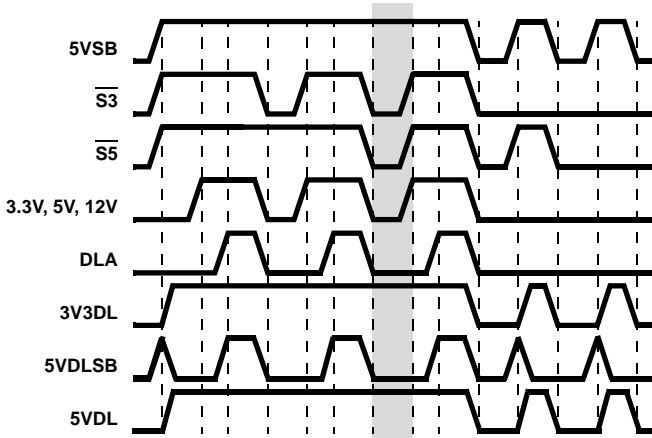

FIGURE 2. 5V_{DUAL} AND 3.3V_{AUX} TIMING DIAGRAM; ISL6506A

Soft-Start

Figures 3 and 4 show the soft-start sequence for the typical application start-up into a sleep state. At time t₀, 5V_{SB} (bias) is applied to the circuit. At time t₁, the 5V_{SB} surpasses POR level. Time t₂, one soft-start interval after t₁, denotes the initiation of soft-start. The 3.3V_{DUAL} rail is brought up through the internal standby LDO through an internal digital soft-start function. Figure 4 shows the 5V_{DUAL} rail initiating a soft-start at time t₂ as well. The ISL6506A will draw 7.5μA into the 5VDLSB for a duration of one soft-start period. This current will enhance the P-MOSFET (Q₂, refer to “Typical Application” on page 2) in a controlled manner. At time t₃, the 3.3V_{DUAL} is in regulation and the 5VDLSB pin is pulled down to ground. If the 5V_{DUAL} rail has not reached the level of the 5V_{SB} rail by time t₃, then the rail will experience a sudden step as the P-MOSFET gate is fully enhanced. The soft-start profile of the 5V_{DUAL} may be altered by placing a capacitor between the gate and drain of the P-MOSFET. Adding this capacitor will increase the gate capacitance and slow down the start of the 5V_{DUAL} rail.

At time t₄, the system has transitioned into S₀ state and the ATX supplies have begun to ramp-up. With the ISL6506, ISL6506B (Figure 3), the 5V_{DUAL} rail will begin to ramp-up from the 5V_{ATX} rail through the body diode of the N-MOSFET (Q₃). The ISL6506A will already have the 5V_{DUAL} rail in regulation (Figure 4). At time t₅, the 12V_{ATX} rail has surpassed the 12V POR level. Time t₆ is three soft-start cycles after the 12V POR level has been surpassed. At time t₆, three events occur simultaneously. The DLA pin is forced to a high impedance state which allows the 12V rail to enhance the two N-MOSFETs (Q₁ and Q₃) that connect the ATX rails to the 3.3V_{DUAL} and 5V_{DUAL} rails. The 5VDLSB pin is actively pulled high, which will turn the P-MOSFET (Q₂) off. Finally, the internal LDO which regulates the 3.3V_{AUX} rail in sleep states is put in standby mode.

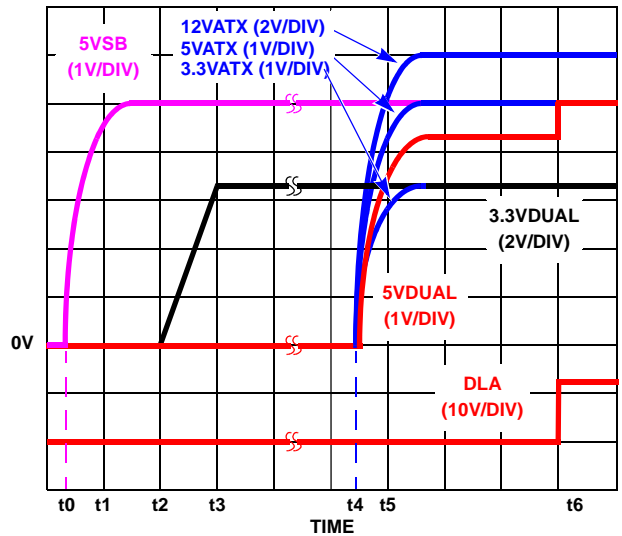

FIGURE 3. ISL6506 AND ISL6506B SOFT-START INTERVAL IN S₄/S₅ STATE AND S₅ TO S₀ TRANSITION

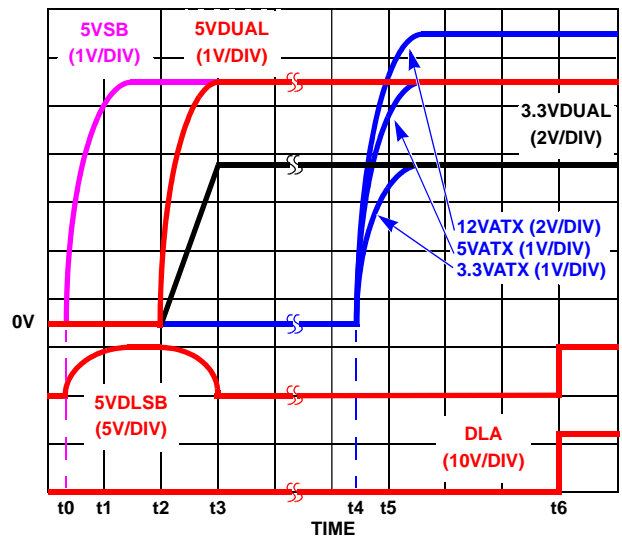

FIGURE 4. SOFT-START INTERVAL FOR ISL6506A IN S₄/S₅ AND S₅ TO S₀ TRANSITION FOR ISL6506 AND S₃ TO S₀ TRANSITION FOR ISL6506, ISL6506A, ISL6506B

Sleep to Wake State Transitions

Figures 3 and 4, starting at time t₄, depict the transitions from sleep states to the S₀ wake state. Figure 3 shows the transition of the ISL6506, ISL6506B from the S₄/S₅ state to the S₀ state. Figure 4 shows how the ISL6506, ISL6506B will transition from the S₃ sleep state into S₀ state. Figure 3 also shows how the ISL6506A transitions from either S₃ or S₄/S₅ in the S₀ state. For all transitions, t₄ depicts the system transition into the S₀ state. Here, the ATX supplies are enabled and begin to ramp up. At time t₅, the 12V_{ATX} rail has exceeded the POR threshold for the ISL6506, ISL6506B and ISL6506A. Three soft-start periods after time t₅, at time t₆, three events occur simultaneously. The DLA pin is forced

to a high impedance state, which allows the 12V rail to enhance the two N-MOSFETs (Q_1 and Q_3) that connect the ATX rails to the 3.3V_{DUAL} and 5V_{DUAL} rails. The 5V_{DL} pin is actively pulled high, which will turn the P-MOSFET (Q_2) off. Finally, the internal LDO which regulates the 3.3V_{DUAL} rail in sleep states is put in standby mode.

Internal Linear Regulator Undervoltage Protection

The undervoltage protection on the internal linear regulator is only active during sleep states and after the initial soft-start ramp of the 3.3V linear regulator. The undervoltage trip point is set at 25% below nominal, or 2.475V.

When an undervoltage is detected, the 3.3V linear regulator is disabled. One soft-start interval later, the 3.3V linear regulator is retried with a soft-start ramp. If the linear regulator is retried 3 times and a fourth undervoltage is detected, then the 3.3V linear regulator is disabled and can only be reset through a POR reset.

Internal Linear Regulator Overcurrent Protection

When an overcurrent condition is detected, the gate voltage to the internal NMOS pass element is reduced, which causes the output voltage of the linear regulator to be reduced. When the output voltage is reduced to the undervoltage trip point, the undervoltage protection is initiated and the output will shutdown.

Layout Considerations

The typical application employing an ISL6506 is a fairly straight forward implementation. Like with any other linear regulator, attention has to be paid to the few potentially sensitive small signal components, such as those connected to sensitive nodes or those supplying critical bypass current.

The power components (pass transistors) and the controller IC should be placed first. The controller should be placed in a central position on the motherboard, not excessively far from the 3.3V_{DUAL} island or the I/O circuitry. Ensure the 3V3AUX connection is properly sized to carry 1A without exhibiting significant resistive losses at the load end. Similarly, the input bias supply (5V_{SB}) carries a similar level of current (for best results, ensure it is connected to its respective source through an adequately sized trace and is properly decoupled). The pass transistors should be placed on pads capable of heatsinking matching the device's power dissipation. Where applicable, multiple via connections to a large internal plane can significantly lower localized device temperature rise.

Placement of the decoupling and bulk capacitors should reflect their purpose. As such, the high-frequency decoupling capacitors should be placed as close as possible to the load they are decoupling; the ones decoupling the controller close to the controller pins, the ones decoupling the load close to the load connector or the load itself (if embedded). Even though bulk capacitance (aluminum electrolytics or tantalum capacitors) placement is not as

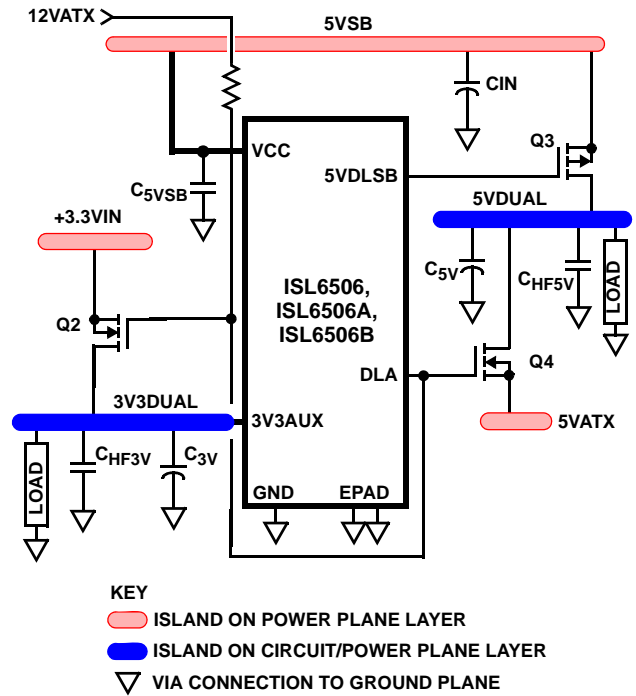

FIGURE 5. PRINTED CIRCUIT BOARD ISLANDS

critical as the high-frequency capacitor placement, having these capacitors close to the load they serve is preferable.

Locate all small signal components close to the respective pins of the control IC, and connect them to ground, if applicable, through a via placed close to the ground pad.

A multi-layer printed circuit board is recommended. Figure 5 shows the connections to most of the components in the circuit. Note that the individual capacitors shown each could represent numerous physical capacitors. Dedicate one solid layer for a ground plane and make all critical component ground connections through vias placed as close to the component terminal as possible. The EPAD should be tied to the ground plane with three to five vias for good thermal management. Dedicate another solid layer as a power plane and break this plane into smaller islands of common voltage levels. Ideally, the power plane should support both the input power and output power nodes. Use copper filled polygons on the top and bottom circuit layers to create power islands connecting the filtering components (output capacitors) and the loads. Use the remaining printed circuit layers for small signal wiring.

Component Selection Guidelines

Output Capacitors Selection

The output capacitors should be selected to allow the output voltage to meet the dynamic regulation requirements of active state operation (S0/S1). The load transient for the various microprocessor system's components may require high quality capacitors to supply the high slew rate (di/dt)

current demands. Thus, it is recommended that the output capacitors be selected for transient load regulation, paying attention to their parasitic components (ESR, ESL).

Also, during the transition between active and sleep states on the 5V_{DUAL} output, there is a short interval of time during which none of the power pass elements are conducting. During this time the output capacitors have to supply all the output current. The output voltage drop during this brief period of time can be easily approximated using Equation 1:

$$\Delta V_{OUT} = I_{OUT} \times \left(ESR_{OUT} + \frac{t_t}{C_{OUT}} \right) \quad (\text{EQ. 1})$$

where:

ΔV_{OUT} = output voltage drop

ESR_{OUT} = output capacitor bank ESR

I_{OUT} = output current during transition

C_{OUT} = output capacitor bank capacitance

t_t = active-to-sleep/sleep-to-active transition time (10 μ s typical)

The output voltage drop is heavily dependent on the ESR (equivalent series resistance) of the output capacitor bank, the choice of capacitors should be such as to maintain the output voltage above the lowest allowable regulation level.

Input Capacitors Selection

The input capacitors for an ISL6506, ISL6506A application must have a sufficiently low ESR so as not to allow the input voltage to dip excessively when energy is transferred to the output capacitors. If the ATX supply does not meet the specifications, certain imbalances between the ATX's outputs and the ISL6506, ISL6506A's regulation levels could have as a result a brisk transfer of energy from the input capacitors to the supplied outputs. At the transition between active and sleep states, such phenomena could be responsible for the 5V_{SB} voltage drooping excessively and affecting the output regulation. The solution to such a potential problem is using larger input capacitors with a lower total combined ESR.

Transistor Selection/Considerations

The ISL6506, ISL6506A usually requires one P-Channel and two N-Channel MOSFETs. All three of these MOSFETs are utilized as ON/OFF switching elements.

One important criteria for selection of transistors for all the switching elements is package selection for efficient removal of heat. The power dissipated in a switch element while on is shown in Equation 2:

$$P_{LOSS} = I_o^2 \times r_{DS(ON)} \quad (\text{EQ. 2})$$

Select a package and heatsink that maintains the junction temperature below the rating with the maximum expected ambient temperature.

Q1, Q3

These N-Channel MOSFETs are used to switch the 3.3V and 5V inputs provided by the ATX supply into the 3.3V_{AUX} and 5V_{DUAL} outputs while in active (S0, S1) state. The main criteria for the selection of these transistors is output voltage budgeting. The maximum $r_{DS(ON)}$ allowed at highest junction temperature can be expressed using Equation 3:

$$r_{DS(ON)max} = \frac{V_{INmin} - V_{OUTmin}}{I_{OUTmax}} \quad (\text{EQ. 3})$$

where:

V_{INmin} = minimum input voltage

V_{OUTmin} = minimum output voltage allowed

I_{OUTmax} = maximum output current

Q2

This is a P-Channel MOSFET used to switch the 5V_{SB} output of the ATX supply into the 5V_{DUAL} output during sleep states. The selection criteria of this device, as with the N-Channel MOSFETs, is proper voltage budgeting. The maximum $r_{DS(ON)}$, however, has to be achieved with only 4.5V of gate-to-source voltage, so a true logic level MOSFET needs to be selected.

Small Outline Exposed Pad Plastic Packages (EPSONIC)

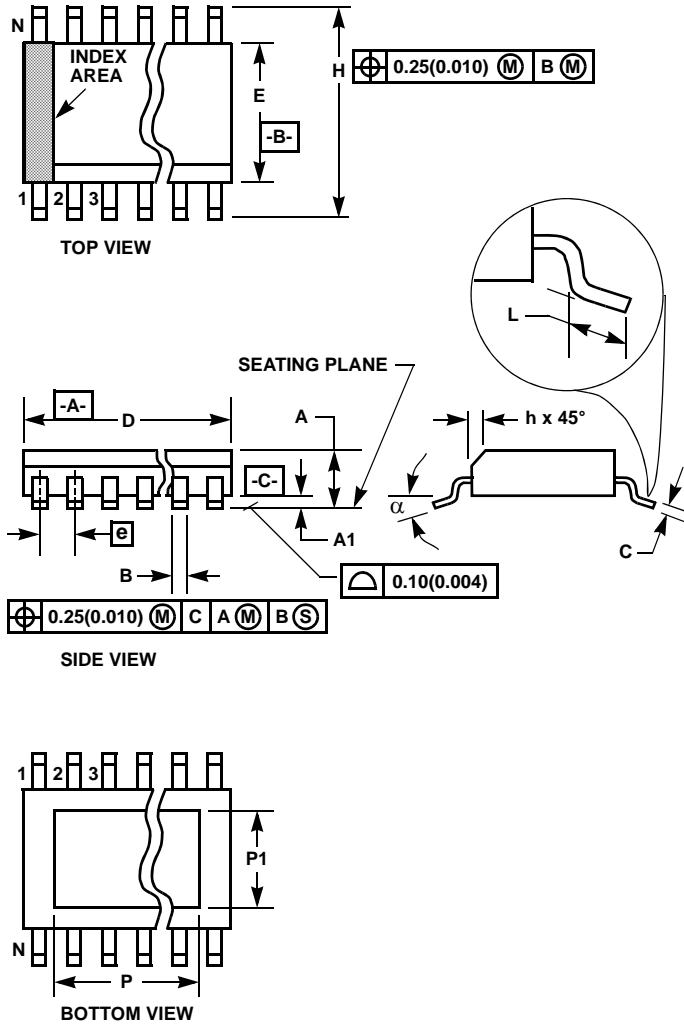

M8.15C
8 LEAD NARROW BODY SMALL OUTLINE EXPOSED PAD
PLASTIC PACKAGE

SYMBOL	INCHES		MILLIMETERS		NOTES
	MIN	MAX	MIN	MAX	
A	0.056	0.066	1.43	1.68	-
A1	0.001	0.005	0.03	0.13	-
B	0.0138	0.0192	0.35	0.49	9
C	0.0075	0.0098	0.19	0.25	-
D	0.189	0.196	4.80	4.98	3
E	0.150	0.157	3.811	3.99	4
e	0.050 BSC		1.27 BSC		-
H	0.230	0.244	5.84	6.20	-
h	0.010	0.016	0.25	0.41	5
L	0.016	0.035	0.41	0.89	6
N	8		8		7
α	0°	8°	0°	8°	-
P	-	0.126	-	3.200	11
P1	-	0.099	-	2.514	11

Rev. 1 6/05

NOTES:

1. Symbols are defined in the "MO Series Symbol List" in Section 2.2 of Publication Number 95.
2. Dimensioning and tolerancing per ANSI Y14.5M-1982.
3. Dimension "D" does not include mold flash, protrusions or gate burrs. Mold flash, protrusion and gate burrs shall not exceed 0.15mm (0.006 inch) per side.
4. Dimension "E" does not include interlead flash or protrusions. Interlead flash and protrusions shall not exceed 0.25mm (0.010 inch) per side.
5. The chamfer on the body is optional. If it is not present, a visual index feature must be located within the crosshatched area.
6. "L" is the length of terminal for soldering to a substrate.
7. "N" is the number of terminal positions.
8. Terminal numbers are shown for reference only.
9. The lead width "B", as measured 0.36mm (0.014 inch) or greater above the seating plane, shall not exceed a maximum value of 0.61mm (0.024 inch).
10. Controlling dimension: MILLIMETER. Converted inch dimensions are not necessarily exact.
11. Dimensions "P" and "P1" are thermal and/or electrical enhanced variations. Values shown are maximum size of exposed pad within lead count and body size.

All Intersil U.S. products are manufactured, assembled and tested utilizing ISO9000 quality systems. Intersil Corporation's quality certifications can be viewed at www.intersil.com/design/quality

Intersil products are sold by description only. Intersil Corporation reserves the right to make changes in circuit design, software and/or specifications at any time without notice. Accordingly, the reader is cautioned to verify that data sheets are current before placing orders. Information furnished by Intersil is believed to be accurate and reliable. However, no responsibility is assumed by Intersil or its subsidiaries for its use; nor for any infringements of patents or other rights of third parties which may result from its use. No license is granted by implication or otherwise under any patent or patent rights of Intersil or its subsidiaries.

For information regarding Intersil Corporation and its products, see www.intersil.com

Looking for pricing, stock, or lifecycle information?

Click below to explore more details on WIN SOURCE:

 [View ISL6506BCBZ-T on WIN SOURCE](#)

 [Intersil Information](#)

Optimize Your Supply Chain with WIN SOURCE Solutions

-  Global Sourcing Solution
-  Obsolete Management
-  Cost Control Management
-  Shortage Management
-  Alternative Solution
-  Excess Inventory Management