

ISL59482

Dual, 500MHz Triple, Multiplexing Amplifiers

FN6209
Rev 4.00
Aug 8, 2014

The ISL59482 contains two independent fixed gain of 2 triple 4:1 MUX amplifiers that feature high slew rate and excellent bandwidth for RGB video switching. Each RGB 4:1 MUX contains binary coded, channel select logic inputs (S0, S1), and separate logic inputs for High Impedance Output (HIZ) and power-down (\overline{EN}) modes. The HIZ state presents a high impedance at the output so that both RGB MUX outputs can be wired together to form an 8:1 RGB MUX amplifier or, they can be used in R-R, G-G, and B-B pairs to form a 4:1 differential input/output MUX. Separate power-down mode controls ($\overline{EN1}$, $\overline{EN2}$,) are included to turn off unneeded circuitry in power sensitive applications. With both \overline{EN} pins pulled high, the ISL59482 enters a standby power mode consuming just 34mW.

TABLE 1. CHANNEL SELECT LOGIC TABLE ISL59482

S1-1, 2	S0-1, 2	$\overline{EN1, 2}$	HIZ1, 2	OUTPUT1, 2
0	0	0	0	IN0 (A, B, C)
0	1	0	0	IN1 (A, B, C)
1	0	0	0	IN2 (A, B, C)
1	1	0	0	IN3 (A, B, C)
X	X	1	X	Power-down
X	X	0	1	High Z

Features

- Dual, triple 4:1 multiplexers for RGB
- 520MHz bandwidth into 500Ω load
- ± 1600 V/ μ s slew rate
- Externally configurable for various video MUX circuits including:
 - 8:1 RGB MUX
 - Two separate 4:1 RGB MUX
 - 4:1 differential RGB video MUX
- Internally fixed gain-of-2
- High impedance outputs (HIZ)
- Power-down mode (\overline{EN})
- ± 5 V operation
- Supply current 16mA/Ch maximum
- Pb-free (RoHS compliant)

Applications

- HDTV/DTV analog inputs
- Video projectors, computer monitors
- Set-top boxes
- Security video
- Broadcast video equipment

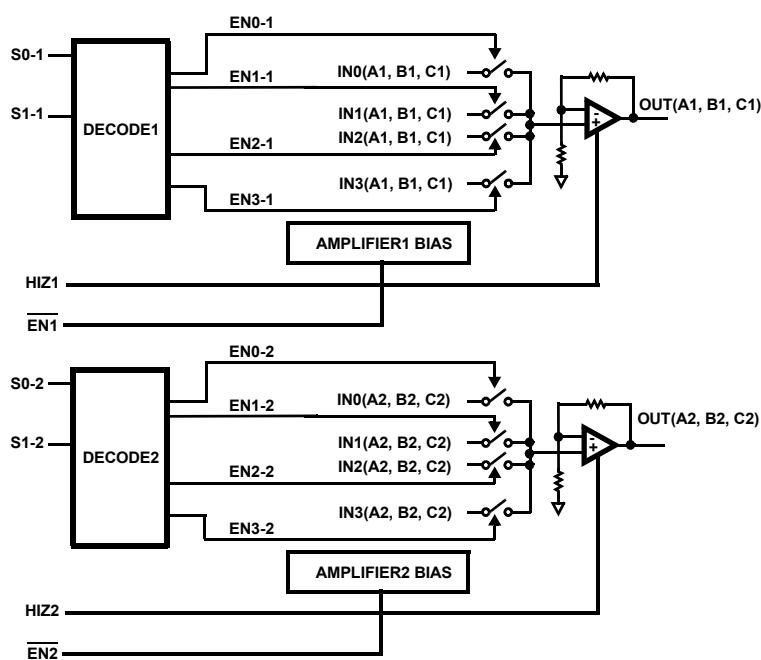

FIGURE 1. ISL59482 FUNCTIONAL DIAGRAM

Ordering Information

PART NUMBER (Notes 1, 2, 3)	PART MARKING	PACKAGE (Pb-Free)	PKG. DWG. #
ISL59482IRZ	ISL59482 IRZ	48 Ld Exposed Pad 7x7 QFN	L48.7x7B
ISL59482EVAL1Z	Evaluation Board		

NOTES:

1. Add "-T*" suffix for tape and reel. Please refer to [TB347](#) for details on reel specifications.
2. These Intersil Pb-free plastic packaged products employ special Pb-free material sets, molding compounds/die attach materials, and 100% matte tin plate plus anneal (e3 termination finish, which is RoHS compliant and compatible with both SnPb and Pb-free soldering operations). Intersil Pb-free products are MSL classified at Pb-free peak reflow temperatures that meet or exceed the Pb-free requirements of IPC/JEDEC J STD-020.
3. For Moisture Sensitivity Level (MSL), please see device information page for [ISL59482](#). For more information on MSL please see tech brief [TB363](#).

Pin Configuration

ISL59482
(48 LD QFN)
TOP VIEW

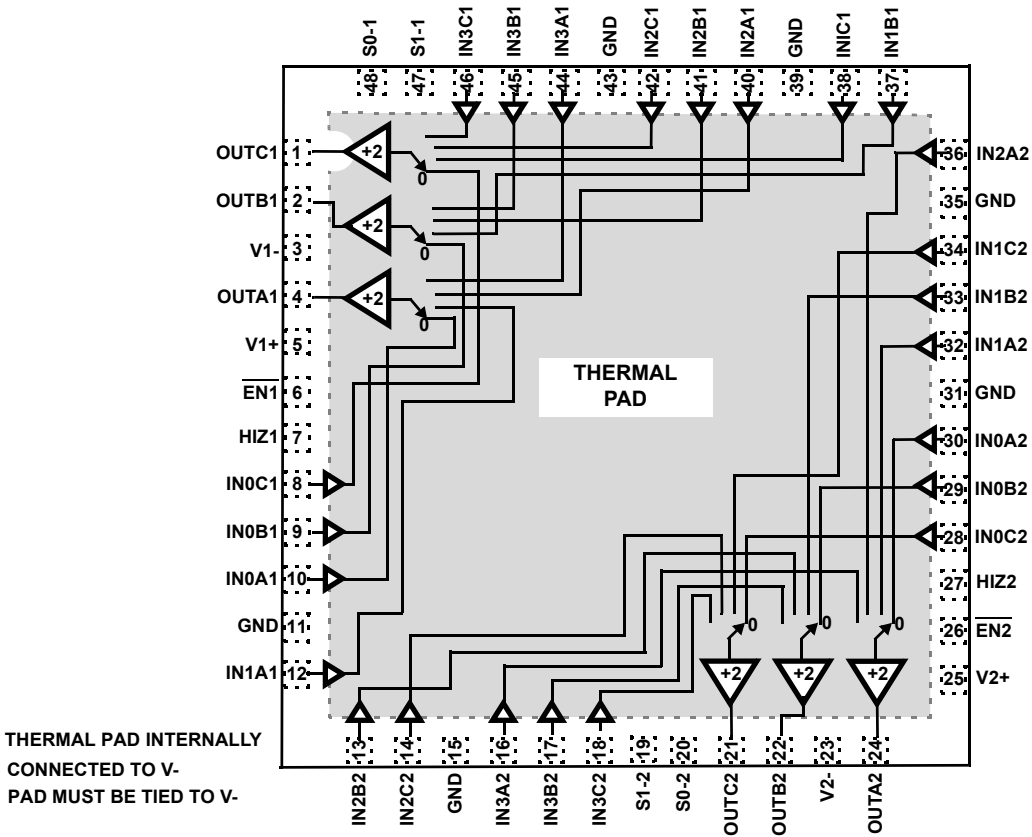

Pin Description

ISL59482 (48 LD QFN)	PIN NAME	EQUIVALENT CIRCUIT	DESCRIPTION
1	OUTC1	Circuit 3	Output of amplifier C1
2	OUTB1	Circuit 3	Output of amplifier B1
3, 23	V1-, V2-	Circuit 4A	Negative power supply #1 and #2
4	OUTA1	Circuit 3	Output of amplifier A1
5, 25	V1+, V2+	Circuit 4A	Positive Power Supply #1 and #2
6	$\overline{\text{EN1}}$	Circuit 2	Device enable (active low) w/internal pull-down resistor. A logic High puts device into power-down mode leaving the logic circuitry active. This state is not recommended for logic control where more than one MUX-amp share the same video output line.
26	$\overline{\text{EN2}}$		
7	HIZ1	Circuit 2	Output disable (active high) w/internal pull-down resistor. A logic high puts the output in a high impedance state. Use this state when more than one MUX-amp share the same video output line.
27	HIZ2		
8	INOC1	Circuit 1	Channel 0 input for amplifier C1
9	INOB1	Circuit 1	Channel 0 input for amplifier B1
10	INOA1	Circuit 1	Channel 0 input for amplifier A1
11	GND	Circuit 4A	Ground pin for amplifier A1
12	IN1A1	Circuit 1	Channel 1 input for amplifier A1
13	IN2B2	Circuit 1	Channel 2 input for amplifier B2
14	IN2C2	Circuit 1	Channel 2 input for amplifier C2
15	GND	Circuit 4B	Ground pin for amplifier C2
16	IN3A2	Circuit 1	Channel 3 input for amplifier A2
17	IN3B2	Circuit 1	Channel 3 input for amplifier B2
18	IN3C2	Circuit 1	Channel 3 input for amplifier C2
19, 47	S1-2, S1-1	Circuit 2	Channel select pin MSB (binary logic code) for amplifiers A2, B2, C2 (S1-2) and A1, B1, C1 (S1-1)
20, 48	S0-2, S0-1	Circuit 2	Channel select pin LSB (binary logic code) for amplifiers A2, B2, C2 (S0-2) and A1, B1, C1 (S0-1)
21	OUTC2	Circuit 2	Output of amplifier C2
22	OUTB2	Circuit 1	Output of amplifier B2
24	OUTA2	Circuit 1	Output of amplifier A2
28	INOC2	Circuit 1	Channel 0 input for amplifier A2
29	INOB2	Circuit 1	Channel 0 input for amplifier B2
30	INOA2	Circuit 1	Channel 0 input for amplifier C2
31	GND	Circuit 4B	Ground pin for amplifier A2
32	IN1A2	Circuit 1	Channel 1 input for amplifier A2
33	IN1B2	Circuit 1	Channel 1 input for amplifier B2
34	IN1C2	Circuit 1	Channel 1 input for amplifier C2
35	GND	Circuit 4B	Ground pin for amplifier B2
36	IN2A2	Circuit 1	Channel 2 input for amplifier A2
37	IN1B1	Circuit 1	Channel 1 input for amplifier B1
38	IN1C1	Circuit 1	Channel 1 input for amplifier C1
39	GND	Circuit 4A	Ground pin for amplifier B1
40	IN2A1	Circuit 1	Channel 2 input for amplifier A1
41	IN2B1	Circuit 1	Channel 2 input for amplifier B1
42	IN2C1	Circuit 1	Channel 2 input for amplifier C1
43	GND	Circuit 4A	Ground pin for amplifier C1
44	IN3A1	Circuit 1	Channel 3 input for amplifier A1
45	IN3B1	Circuit 1	Channel 3 input for amplifier B1
46	IN3C1	Circuit 1	Channel 3 input for amplifier C1

Absolute Maximum Ratings ($T_A = +25^\circ\text{C}$)

Supply Voltage (V+ to V-)	11V
Input Voltage	V- -0.5V, V+ +0.5V
Supply Turn-on Slew Rate	1V/ μs
Digital and Analog Input Current (Note 4)	50mA
Output Current (Continuous)	50mA
ESD Rating	
Human Body Model (Per MIL-STD-883 Method 3015.7)	2500V
Machine Model	300V

Thermal Information

Thermal Resistance (Typical)	θ_{JA} ($^\circ\text{C}/\text{W}$)	θ_{JC} ($^\circ\text{C}/\text{W}$)
48 Ld QFN Package (Notes 5, 6)	37	5
Storage Temperature Range	-65 $^\circ\text{C}$ to +150 $^\circ\text{C}$	
Ambient Operating Temperature	-40 $^\circ\text{C}$ to +85 $^\circ\text{C}$	
Operating Junction Temperature	-40 $^\circ\text{C}$ to +125 $^\circ\text{C}$	
Power Dissipation	see Figure 26	
Pb-Free Reflow Profile	see TB493	

CAUTION: Do not operate at or near the maximum ratings listed for extended periods of time. Exposure to such conditions may adversely impact product reliability and result in failures not covered by warranty.

NOTES:

- If an input signal is applied before the supplies are powered up, the input current must be limited to these maximum values.
- θ_{JA} is measured in free air with the component mounted on a high effective thermal conductivity test board with "direct attach" features. See Tech Brief TB379.
- For θ_{JC} , the "case temp" location is the center of the exposed metal pad on the package underside.

Electrical Specifications $V_{1+} = V_{2+} = +5\text{V}$, $V_{1-} = V_{2-} = -5\text{V}$, $\text{GND} = 0\text{V}$, $T_A = +25^\circ\text{C}$, Input Video = 0.5V_{P-P} and $R_L = 500\Omega$ to GND, $C_L = 5\text{pF}$ unless otherwise specified.

PARAMETER	DESCRIPTION	CONDITIONS	MIN (Note 7)	TYP	MAX (Note 7)	UNIT
GENERAL						
+I _S Enabled	Enabled Supply Current	No load, V _{IN} = 0V, EN1, EN2 Low	77	88	100	mA
-I _S Enabled	Enabled Supply Current	No load, V _{IN} = 0V, EN1, EN2 Low	-92	-82	-70	mA
+I _S Disabled	Disabled Supply Current	No load, V _{IN} = 0V, EN1, EN2 High	4	6.8	8	mA
-I _S Disabled	Disabled Supply Current	No load, V _{IN} = 0V, EN1, EN2 High	-80	-12		μA
V _{OUT}	Positive and Negative Output Swing	V _{IN} = $\pm 2.5\text{V}$, R _L = 500 Ω	± 3.8	± 4.0	± 4.2	V
I _{OUT}	Output Current	R _L = 10 Ω to GND	± 80	± 135	± 180	mA
V _{OS}	Output Offset Voltage		-60	-25	20	mV
I _b	Input Bias Current	V _{IN} = 0V	-10	-2	+10	μA
R _{OUT}	HIZ Output Resistance	HIZ = Logic High	700	1000	1300	Ω
R _{OUT}	Enabled Output Resistance	HIZ = Logic Low		0.1		Ω
R _{IN}	Input Resistance	V _{IN} = $\pm 1.75\text{V}$		10		M Ω
A _{CL} or A _V	Voltage Gain	V _{IN} = $\pm 0.75\text{V}$, R _L = 500 Ω	1.94	1.99	2.04	V/V
I _{HIZ}	Output Current in Three-state	V _{OUT} = 0V		15		μA
LOGIC						
V _{IH}	Input High Voltage (Logic Inputs)			2		V
V _{IL}	Input Low Voltage (Logic Inputs)			0.8		V
I _{IH}	Input High Current (Logic Inputs)	V _H = 5V	200	260	320	μA
I _{IL}	Input Low Current (Logic Inputs)	V _L = 0V	-10	-2	+10	μA
AC GENERAL						
PSRR	Power Supply Rejection Ratio	DC, PSRR V+ and V- combined V _{OUT} = 0dBm	45	53		dB
Xtalk	Channel-to-Channel Crosstalk	f = 10MHz, ChX-Ch Y-Talk V _{IN} = 1V _{P-P} ; C _L = 1.2pF		65		dB
Off - ISO	Off-state Isolation	f = 10MHz, Ch-Ch Off-Isolation V _{IN} = 1V _{P-P} ; C _L = 1.2pF		90		dB
dG	Differential Gain Error	NTC-7, R _L = 150, C _L = 1.2pF		0.008		%
dP	Differential Phase Error	NTC-7, R _L = 150, C _L = 1.2pF		0.01		$^\circ$

Electrical Specifications $V_{1+} = V_{2+} = +5V$, $V_{1-} = V_{2-} = -5V$, $GND = 0V$, $T_A = +25^\circ C$, Input Video = $0.5V_{P-P}$ and $R_L = 500\Omega$ to GND, $C_L = 5pF$ unless otherwise specified. (Continued)

PARAMETER	DESCRIPTION	CONDITIONS	MIN (Note 7)	TYP	MAX (Note 7)	UNIT
BW	Small Signal -3dB Bandwidth	$V_{OUT} = 0.2V_{P-P}$; $R_L = 500\Omega$, $C_L = 1.2pF$		520		MHz
		$V_{OUT} = 0.2V_{P-P}$; $R_L = 150\Omega$, $C_L = 1.2pF$		420		MHz
	Large Signal -3dB Bandwidth	$V_{OUT} = 2V_{P-P}$; $R_L = 500\Omega$, $C_L = 1.2pF$		250		MHz
		$V_{OUT} = 2V_{P-P}$; $R_L = 150\Omega$, $C_L = 1.2pF$		230		MHz
FBW	0.1dB Bandwidth	$V_{OUT} = 2V_{P-P}$; $R_L = 500\Omega$, $C_L = 1.2pF$		35		MHz
		$V_{OUT} = 2V_{P-P}$; $R_L = 150\Omega$, $C_L = 1.2pF$		90		MHz
SR	Slew Rate	25% to 75%, $R_L = 150\Omega$, Input Enabled, $C_L = 1.5pF$		1600		V/ μs
TRANSIENT RESPONSE						
t_r , t_f Large Signal	Large Signal Rise, Fall Times, t_r , t_f , 10% to 90%	$V_{OUT} = 2V_{P-P}$; $R_L = 500\Omega$, $C_L = 1.2pF$		1.2		ns
		$V_{OUT} = 2V_{P-P}$; $R_L = 150\Omega$, $C_L = 1.2pF$		1.2		ns
t_r , t_f Small Signal	Small Signal Rise, Fall Times, t_r , t_f , 10% to 90%	$V_{OUT} = 0.2V_{P-P}$; $R_L = 500\Omega$, $C_L = 1.2pF$		0.7		ns
		$V_{OUT} = 0.2V_{P-P}$; $R_L = 150\Omega$, $C_L = 1.2pF$		0.8		ns
t_s 0.1%	Settling Time to 0.1%	$V_{OUT} = 2V_{P-P}$; $R_L = 500\Omega$, $C_L = 1.2pF$		22		ns
		$V_{OUT} = 2V_{P-P}$; $R_L = 150\Omega$, $C_L = 1.2pF$		24		ns
t_s 1%	Settling Time to 1%	$V_{OUT} = 2V_{P-P}$; $R_L = 500\Omega$, $C_L = 1.2pF$		5		ns
		$V_{OUT} = 2V_{P-P}$; $R_L = 150\Omega$, $C_L = 1.2pF$		7		ns
SWITCHING CHARACTERISTICS						
V_{GLITCH}	Channel-to-Channel Switching Glitch	$V_{IN} = 0V$, $C_L = 1.2pF$		60		mV_{P-P}
	\overline{EN} Switching Glitch	$V_{IN} = 0V$, $C_L = 1.2pF$		200		mV_{P-P}
	HIZ Switching Glitch	$V_{IN} = 0V$, $C_L = 1.2pF$		300		mV_{P-P}
t_{SW-L-H}	Channel Switching Time Low-to-High	1.2V logic threshold to 10% movement of analog output		22		ns
t_{SW-H-L}	Channel Switching Time High-to-Low	1.2V logic threshold to 10% movement of analog output		25		ns
tpd	Propagation Delay	10% to 10%		0.9		ns

NOTE:

7. Compliance to datasheet limits is assured by one or more methods: production test, characterization and/or design.

Typical Performance Curves $V_S = \pm 5V, R_L = 500\Omega$ to GND, $T_A = +25^\circ C$, unless otherwise specified.

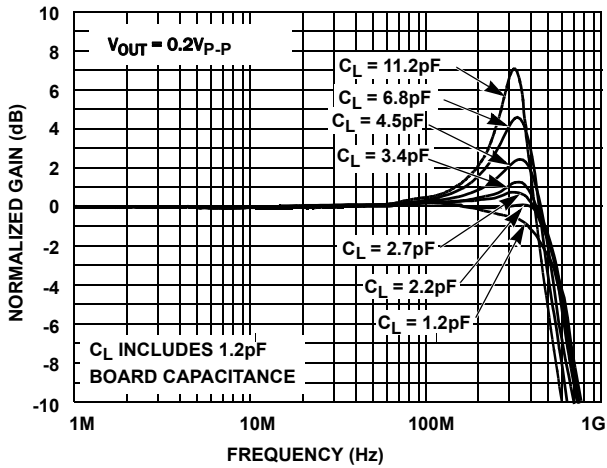

FIGURE 2. SMALL SIGNAL GAIN vs FREQUENCY vs C_L INTO 500Ω LOAD

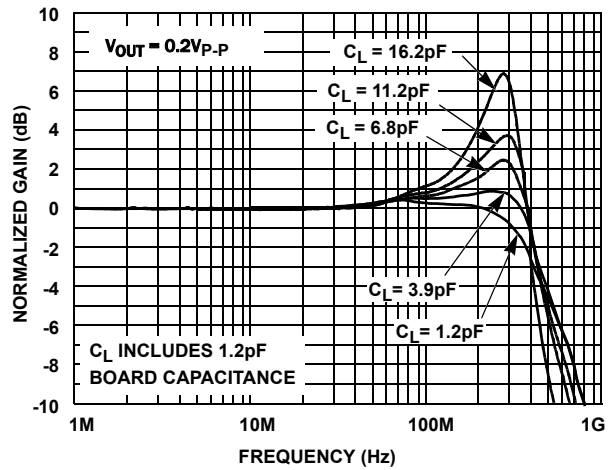

FIGURE 3. SMALL SIGNAL GAIN vs FREQUENCY vs C_L INTO 150Ω LOAD

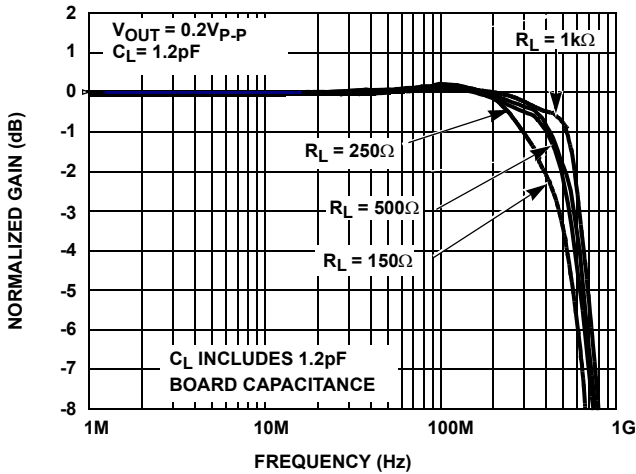

FIGURE 4. GAIN vs FREQUENCY vs R_L

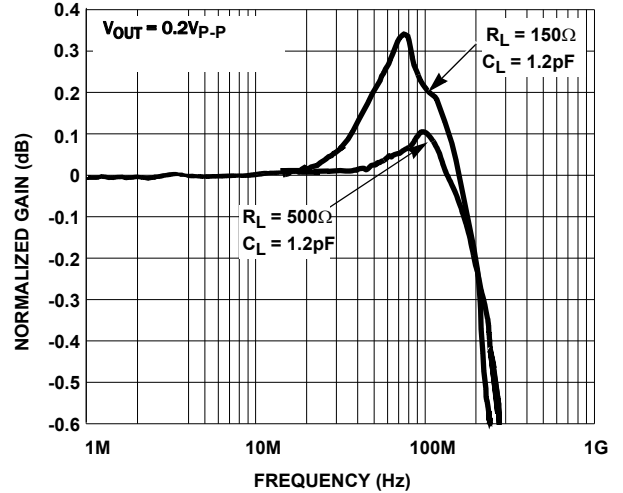

FIGURE 5. 0.1dB GAIN FLATNESS

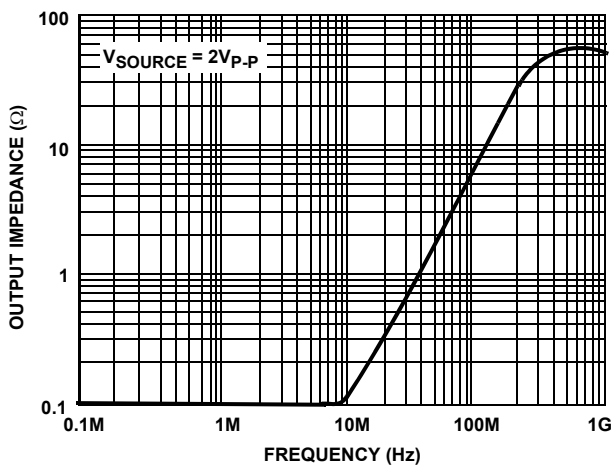

FIGURE 6. Z_{OUT} vs FREQUENCY - ENABLED

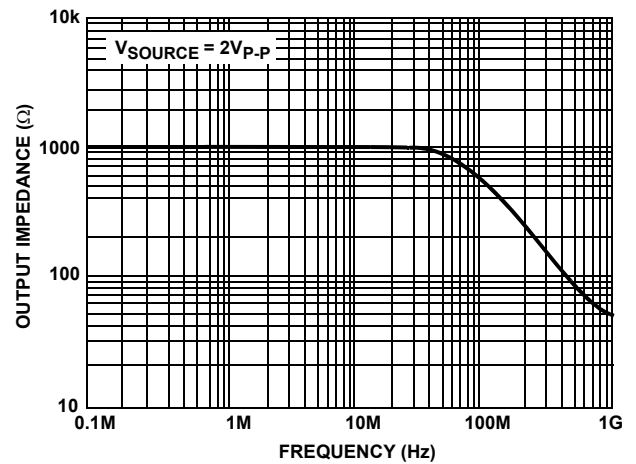

FIGURE 7. Z_{OUT} vs FREQUENCY - Hi-Z

Typical Performance Curves $V_S = \pm 5V$, $R_L = 500\Omega$ to GND, $T_A = +25^\circ C$, unless otherwise specified. (Continued)

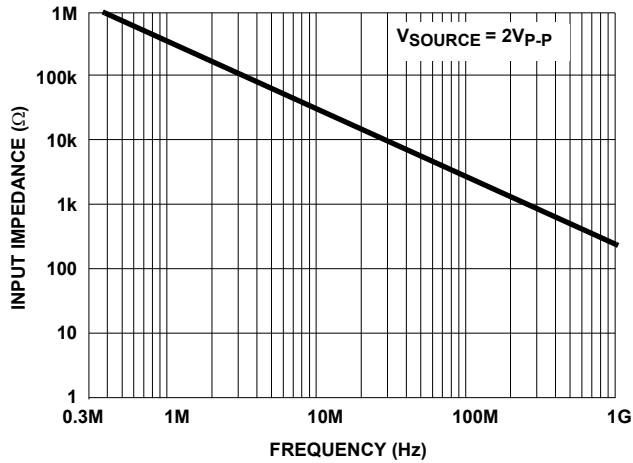

FIGURE 8. Z_{IN} vs FREQUENCY

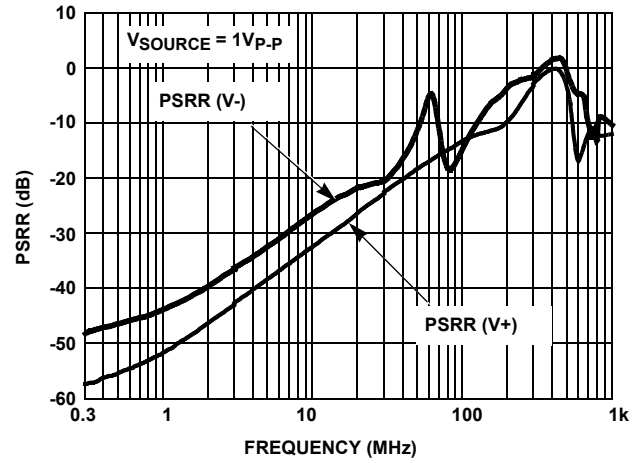

FIGURE 9. PSRR vs FREQUENCY

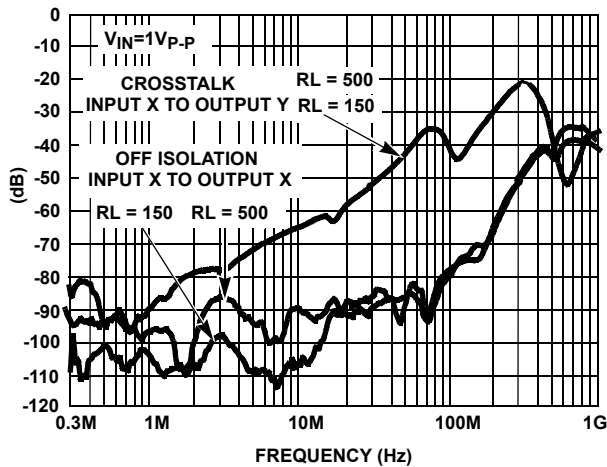

FIGURE 10. CROSSTALK AND OFF-ISOLATION

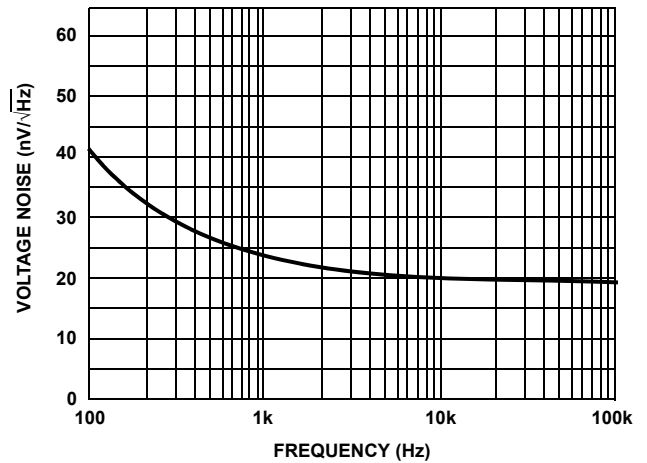

FIGURE 11. INPUT NOISE vs FREQUENCY

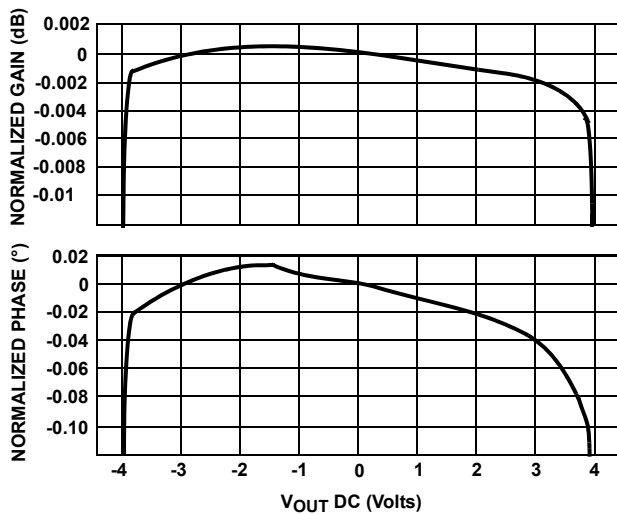

FIGURE 12. DIFFERENTIAL GAIN AND PHASE; $V_{OUT} = 0.2V_{P-P}$
 $F_0 = 3.58MHz$; $R_L = 500\Omega$

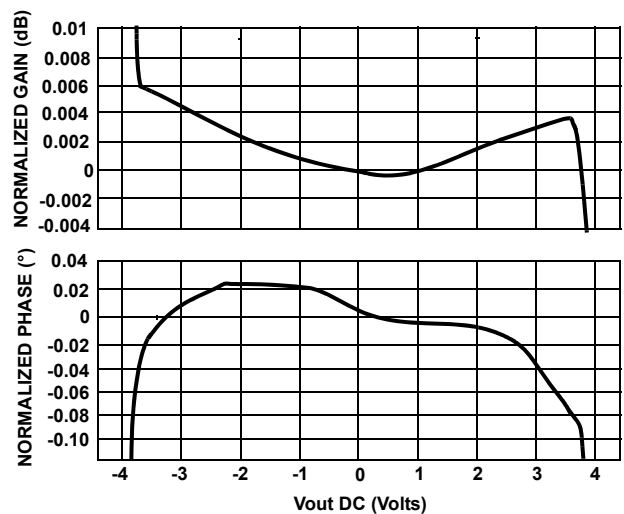

FIGURE 13. DIFFERENTIAL GAIN AND PHASE; $V_{OUT} = 0.2V_{P-P}$
 $F_0 = 3.58MHz$; $R_L = 150\Omega$

Typical Performance Curves $V_S = \pm 5V$, $R_L = 500\Omega$ to GND, $T_A = +25^\circ C$, unless otherwise specified. (Continued)



FIGURE 14. SMALL SIGNAL TRANSIENT RESPONSE; $R_L = 500\Omega$

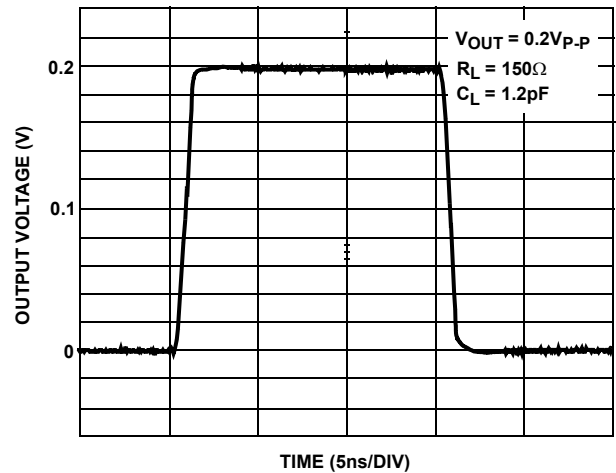

FIGURE 15. SMALL SIGNAL TRANSIENT RESPONSE; $R_L = 150\Omega$

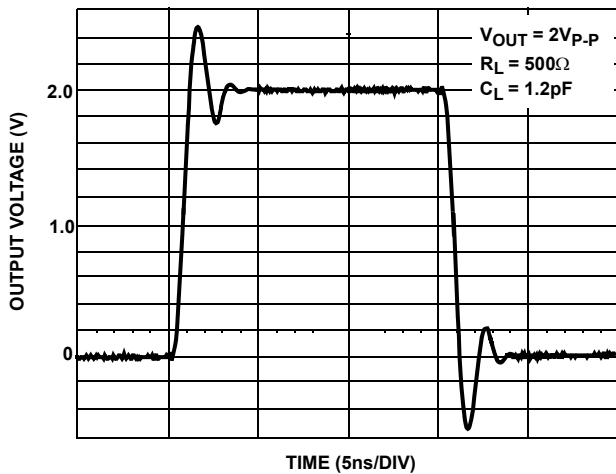

FIGURE 16. LARGE SIGNAL TRANSIENT RESPONSE; $R_L = 500\Omega$



FIGURE 17. LARGE SIGNAL TRANSIENT RESPONSE; $R_L = 150\Omega$

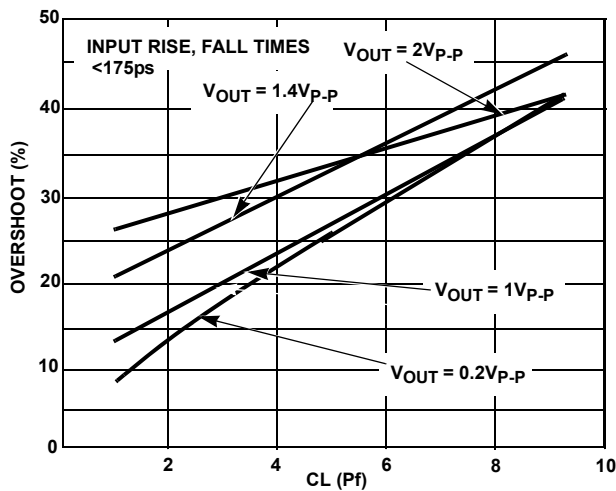

FIGURE 18. PULSE OVERSHOOT vs V_{OUT} , C_L ; $R_L = 500\Omega$

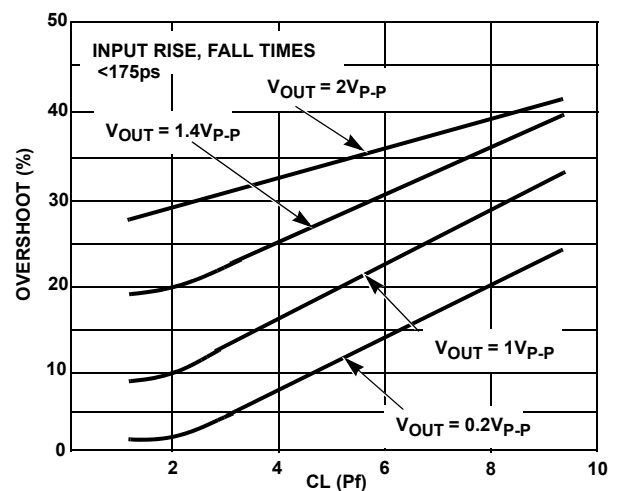

FIGURE 19. PULSE OVERSHOOT vs V_{OUT} , C_L ; $R_L = 150\Omega$

Typical Performance Curves $V_S = \pm 5V$, $R_L = 500\Omega$ to GND, $T_A = +25^\circ C$, unless otherwise specified. (Continued)

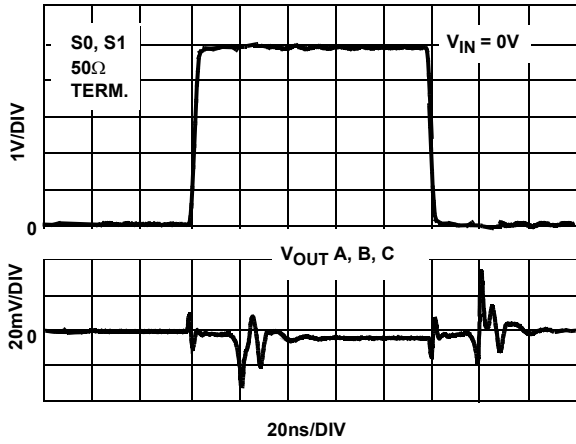

FIGURE 20. CHANNEL-TO-CHANNEL SWITCHING GLITCH $V_{IN} = 0V$

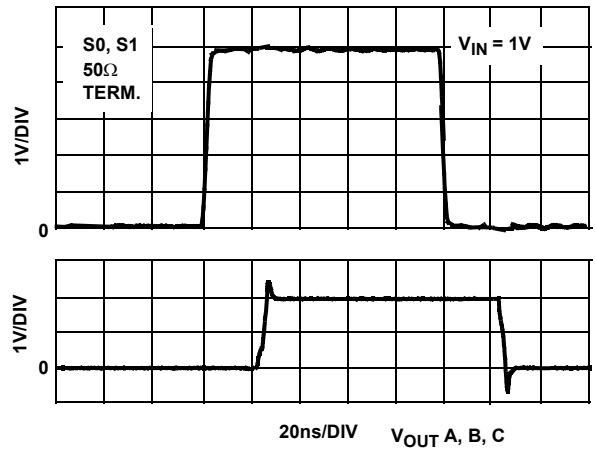

FIGURE 21. CHANNEL-TO-CHANNEL TRANSIENT RESPONSE $V_{IN} = 1V$

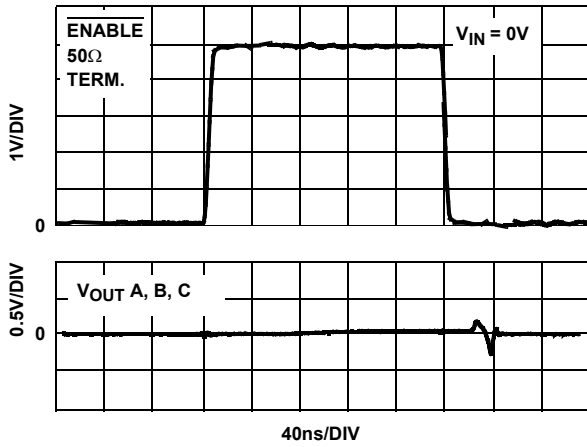

FIGURE 22. \overline{ENABLE} SWITCHING GLITCH $V_{IN} = 0V$

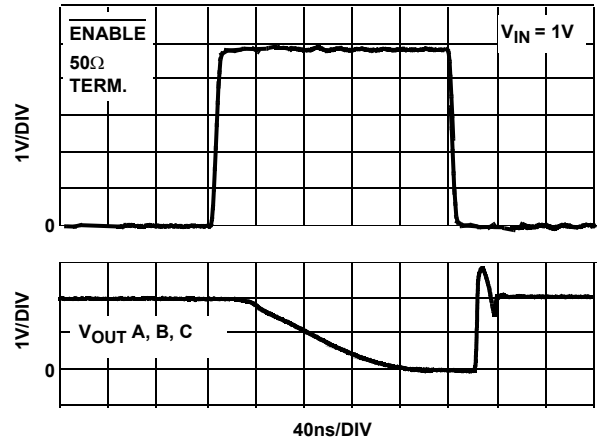

FIGURE 23. \overline{ENABLE} TRANSIENT RESPONSE $V_{IN} = 1V$

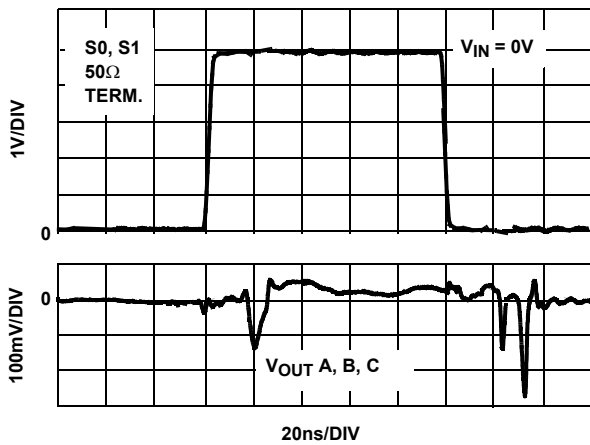

FIGURE 24. HIZ SWITCHING GLITCH $V_{IN} = 0V$

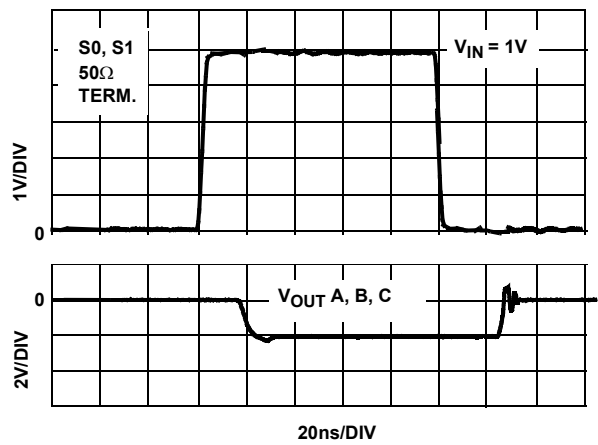

FIGURE 25. HIZ TRANSIENT RESPONSE $V_{IN} = 1V$

Typical Performance Curves $V_S = \pm 5V$, $R_L = 500\Omega$ to GND, $T_A = +25^\circ C$, unless otherwise specified. (Continued)

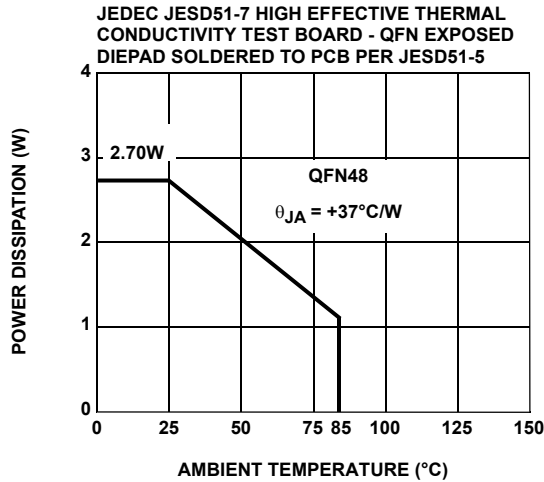
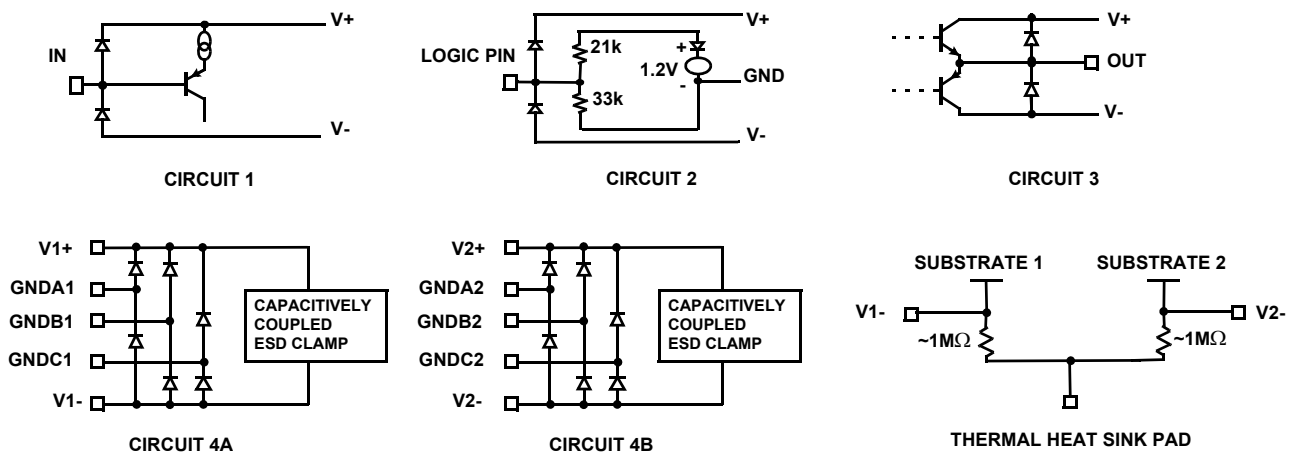

FIGURE 26. PACKAGE POWER DISSIPATION vs AMBIENT TEMPERATURE

Pin Equivalent Circuits



AC Test Circuits

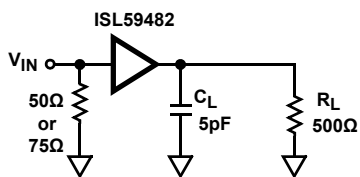

FIGURE 27A. TEST CIRCUIT WITH OPTIMAL OUTPUT LOAD

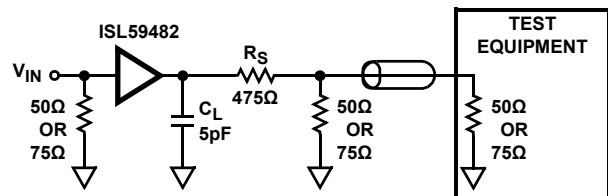

FIGURE 27B. TEST CIRCUIT FOR MEASURING WITH 50Ω OR 75Ω INPUT TERMINATED EQUIPMENT

AC Test Circuits (Continued)

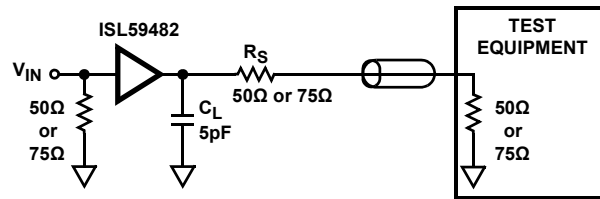

FIGURE 27C. BACKLOADED TEST CIRCUIT FOR VIDEO CABLE APPLICATION. BANDWIDTH AND LINEARITY FOR R_L LESS THAN 500Ω WILL BE DEGRADED.

FIGURE 27. TEST CIRCUITS

Figure 27A illustrates the optimum output load for testing AC performance. Figure 27B illustrates the optimum output load when connecting to a 50Ω input terminated equipment.

Application Information

General

The ISL59482 is ideal as the matrix element of high performance switchers and routers. Key features include internal fixed gain of 2, high impedance buffered analog inputs and excellent AC performance at output loads down to 150Ω for video cable-driving. The current feedback output amplifiers are stable operating into capacitive loads.

Ground Connections

For the best isolation and crosstalk rejection, all GND pins must connect to the GND plane.

Power-up Considerations

The ESD protection circuits use internal diodes from all pins the V+ and V- supplies. In addition, a dV/dt-triggered clamp is connected between the V+ and V- pins, as shown in the Equivalent Circuits 1 through 4 section of the "Pin Description" on page 3. The dV/dt triggered clamp imposes a maximum supply turn-on slew rate of 1V/μs. Damaging currents can flow for power supply rates-of-rise in excess of 1V/μs, such as during hot plugging. Under these conditions, additional methods should be employed to ensure the rate of rise is not exceeded.

Consideration must be given to the order in which power is applied to the V+ and V- pins, as well as analog and logic input pins. Schottky diodes (Motorola MBR0550T or equivalent) connected from V+ to ground and V- to ground (Figure 28) will shunt damaging currents away from the internal V+ and V- ESD diodes in the event that the V+ supply is applied to the device before the V- supply. One Schottky can be used to protect both V+ power supply pins, and a second for the protection of both V- pins.

If positive voltages are applied to the logic or analog video input pins before V+ is applied, current will flow through the internal

ESD diodes to the V+ pin. The presence of large decoupling capacitors and the loading effect of other circuits connected to V+, can result in damaging currents through the ESD diodes and other active circuits within the device. Therefore, adequate current limiting on the digital and analog inputs is needed to prevent damage during the time the voltages on these inputs are more positive than V+.

HIZ State

Each internal 4:1 triple MUX-amp has a three-state output control pin (HIZ1 and HIZ2). Each has an internal pull-down resistor to set the output to the enabled state with no connection to the HIZ pin. The HIZ state is established within approximately 20ns by placing a logic high (>2V) on the HIZ pin. If the HIZ state is selected, the output is a high impedance 1.4MΩ with approximately 1.5pF in parallel with a 10μA bias current from the output. When more than one MUX shares a common output, the high impedance state loading effect is minimized over the maximum output voltage swing and maintains its high Z even in the presence of high slew rates. The supply current during this state is the same as the active state.

EN and Power-down States

The EN pins are active low. An internal pull-down resistor ensures the device will be active with no connection to the \overline{EN} pins. The Power-down state is established within approximately 80ns, if a logic high (>2V) is placed on the \overline{EN} pins. In the Power-down state, supply current is reduced significantly by shutting the three amplifiers off. The output presents a high impedance to the output pin, however, there is a risk that the disabled amplifier output can be back-driven at signal voltage levels exceeding 2V_{P-P}. Under this condition, large incoming slew rates can cause fault currents of tens of mA. Therefore, the parallel connection of multiple outputs is not recommended unless the application can tolerate the limited power-down output impedance.

Limiting the Output Current

No output short circuit current limit exists on these parts. All applications need to limit the output current to less than 50mA. Adequate thermal heat sinking of the parts is also required.

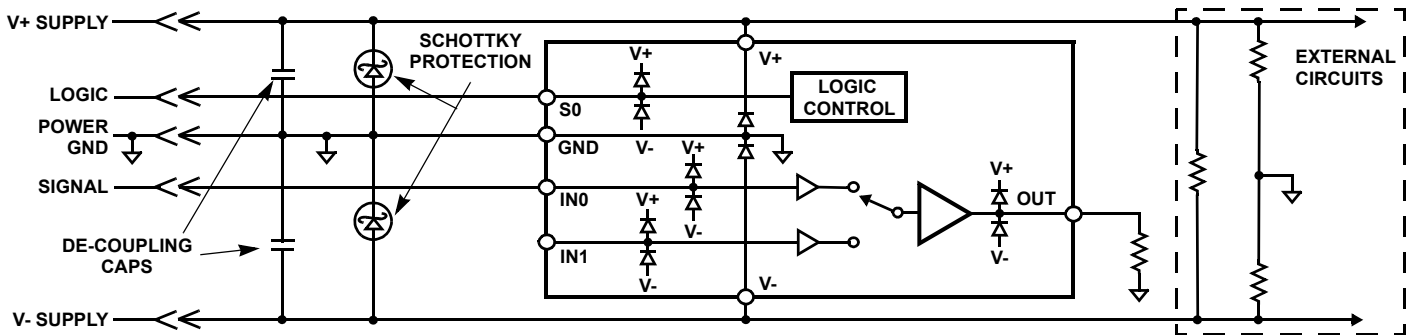

FIGURE 28. SCHOTTKY PROTECTION CIRCUIT

PC Board Layout

The AC performance of this circuit depends greatly on the care taken in designing the PC board. The following are recommendations to achieve optimum high frequency performance from your PC board.

- The use of low inductance components such as chip resistors and chip capacitors is strongly recommended.
- Minimize signal trace lengths. Trace inductance and capacitance can easily limit circuit performance. Avoid sharp corners, use rounded corners when possible. Vias in the signal lines add inductance at high frequency and should be avoided. PCB traces greater than 1" begin to exhibit transmission line characteristics with signal rise/fall times of 1ns or less. High frequency performance may be degraded for traces greater than one inch, unless strip line are used.
- Match channel-to-channel analog I/O trace lengths and layout symmetry. This will minimize propagation delay mismatches.
- Maximize use of AC decoupled PCB layers. All signal I/O lines should be routed over continuous ground planes (i.e. no split planes or PCB gaps under these lines). Avoid vias in the signal I/O lines.
- Use proper value and location of termination resistors. Termination resistors should be as close to the device as possible.
- When testing use good quality connectors and cables, matching cable types and keeping cable lengths to a minimum.
- Minimum of 2 power supply decoupling capacitors are recommended (1000pF, 0.01μF) as close to the devices as possible. Avoid vias between the cap and the device because vias add unwanted inductance. Larger caps can be farther away. When vias are required in a layout, they should be routed as far away from the device as possible.
- The NIC pins are placed on both sides of the input pins. These pins are not internally connected to the die. It is recommended these pins be tied to ground to minimize crosstalk.

The QFN Package Requires Additional PCB Layout Rules for the Thermal Pad

The thermal pad is electrically connected to V- supply through the high resistance IC substrate. Its primary function is to provide

heat sinking for the IC. However, because of the connection to the V1- and V2- supply pins through the substrate, the thermal pad must be tied to the V- supply to prevent unwanted current flow to the thermal pad. Do **not** tie this pin to GND as this could result in large back biased currents flowing between GND and the V- pins. Maximum AC performance is achieved if the thermal pad is attached to a dedicated decoupled layer in a mult-layered PC board. In cases where a dedicated layer is not possible, AC performance may be reduced at upper frequencies.

The thermal pad requirements are proportional to power dissipation and ambient temperature. A dedicated layer eliminates the need for individual thermal pad area. When a dedicated layer is not possible, an isolated thermal pad on another layer should be used. Pad area requirements should be evaluated on a case by case basis.

MUX Application Circuits

Each of the two 4:1 triple MUX amplifiers have their own binary coded, TTL compatible channel select logic inputs (S0-1, 2, and S1-1, 2). All three amplifiers are switched simultaneously from their respective inputs with S0-1 S1-1 controlling MUX-amp1, and S0-2, S1-2 controlling MUX-amp2.

The HIZ control inputs (HIZ1, HIZ2) and device enable control inputs (EN1 and EN2) control MUX-amp1 and MUX-amp2 in a similar fashion. The individual control for each 4:1 triple MUX enables external connections to configure the device for different MUX applications.

8:1 RGB Video MUX

For a triple input RGB 8:1 MUX (Figure 5), the RGB amplifier outputs of MUX-amp1 are parallel connected to the RGB amplifier outputs of MUX-amp2 to produce the single RGB video output. Input channels CH0 to CH3 are assigned to MUX-amp1, and channels CH4 through CH7 are assigned to MUX-amp2. Channels CH0 through CH3 are selected by setting HIZ1 low, HIZ2 high (enables MUX-amp1 and three-states MUX-amp2) and the appropriate channel select logic to S0-1, S1-1. Reversing the logic inputs of HIZ1, HIZ2 switches from MUX-amp1 to MUX-amp2 enabling the selection of channels CH4 through CH7. The channel select inputs are parallel connected (S0-1 to S0-2) and (S1-1 to S1-2) to form two logic controls S0, S1. A single S2 control is split into complimentary logic inputs for HIZ1 and HIZ2 to produce a chip select function for the MSB. The logic control truth table is shown in Figure 29.

4:1 RGB Differential Video MUX

Connecting the channel select pins in parallel (S0-1 to S0-2 and S1-1 to S1-2) converts the 8 individual RGB video inputs into 4 differential RGB input pairs. The amplifier RGB outputs are similarly paired resulting in a fully differential 4:1 RGB MUX amp

shown in [Figure 30](#). Connecting HIZ1 and HIZ2 to +5V disables the 4:1 differential MUX, and enables the connection of additional differential connected MUX amplifiers to the same outputs, thus allowing input expansion to 8:1 or more.

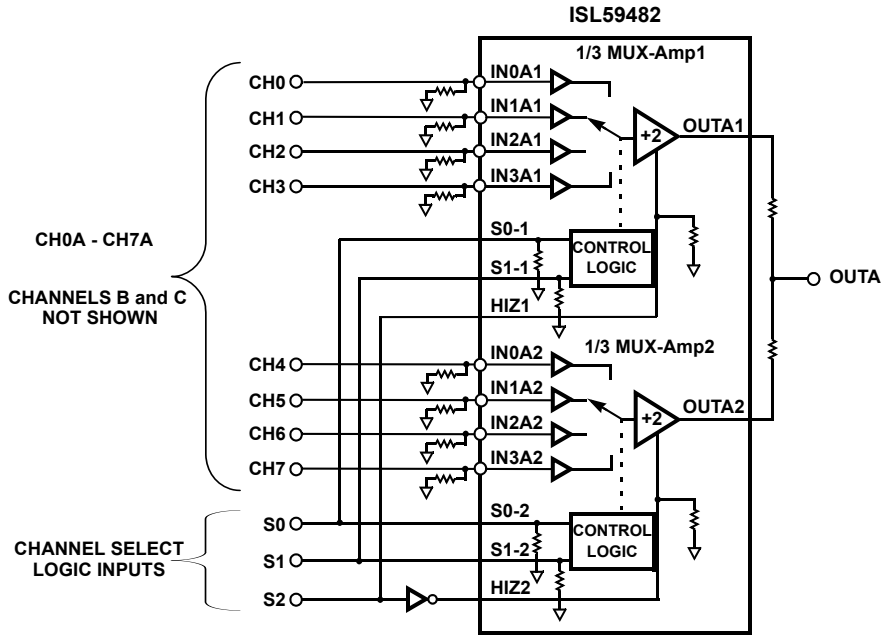

CHANNEL SELECT TRUTH TABLE
8:1 VIDEO MUX

S2	S1	S0	OUTA, B, C
0	0	0	CH0A, B, C
0	0	1	CH1A, B, C
0	1	0	CH2A, B, C
0	1	1	CH3A, B, C
1	0	0	CH4A, B, C
1	0	1	CH5A, B, C
1	1	0	CH6A, B, C
1	1	1	CH7A, B, C

FIGURE 29. APPLICATION CIRCUIT FOR 8:1 RGB VIDEO MUX

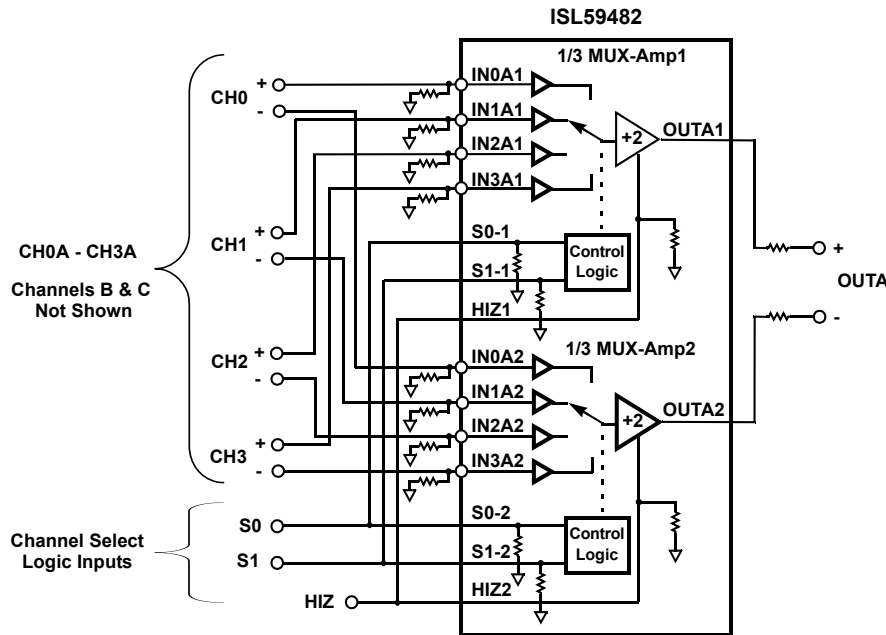

CHANNEL SELECT TRUTH TABLE
4:1 DIFFERENTIAL VIDEO MUX

S1	S0	OUTA, B, C
0	0	CH0A, B, C
0	1	CH1A, B, C
1	0	CH2A, B, C
1	1	CH3A, B, C

FIGURE 30. APPLICATION CIRCUIT FOR 4:1 RGB DIFFERENTIAL VIDEO MUX

Revision History

The revision history provided is for informational purposes only and is believed to be accurate, but not warranted. Please go to web to make sure you have the latest revision.

DATE	REVISION	CHANGE
August 8, 2014	FN6209.4	Removed Important Note above Electrical Spec Table. Min and Max Note is now in its place. Changed T _{ja} in Thermal Information from 23 to 37. Removed Low Effective Power Dissipation Curve and Updated High Effective Power Dissipation Curve on page 10 showing correction from 23 to 37. Changed "-Is Enabled" spec from -90mA to -92mA MIN, on page 4 of the datasheet.
June 20, 2012	FN6209.3	<ul style="list-style-type: none"> - Converted to New Intersil Template and following Intersil standards: - Updated Pb-free bullet in Features on page 1 - Updated Caution statement per legal's new verbiage on page 4. - Added Thermal Information, T_{ja} and respective notes, Pb-Free Reflow link to Abs Max Table on page 4. - Removed Tape & Reel column and part from Ordering Information on page 2 and added note which reads "Add "-T*" suffix for tape and reel." The "*" covers all possible tape and reel options. Added Eval board and MSL note and Added TB347 link. - Added on page 5 Compliance note in Min Max column of spec tables which reads "Compliance to datasheet limits is assured by one or more methods: production test, characterization and/or design." - Updated Intersil Trademark statement at bottom of page 1 per directive from Legal. - Added Revision History and Products Information on page 14. - Page 4, changed upper limit of "Enabled Supply Current" from: 96mA to: 100mA - Changed upper limit of "Disabled Supply Current" from: 7.6mA to: 8mA
December 22, 2006	FN6209.2	Page 4, Electrical Specs: General Parameter, I _b - changed MIN to -10μA and MAX to +10μA Logic Parameter, I _{lil} - changed MIN to -10μA and MAX to +10μA
December 15, 2006	FN6209.1	Changed spec table min/max values in +Is Enabled Min - from 80 to 77 and the -Is Enabled Max - from -74 to -70. Replaced POD page with most updated. No to the WEB until FGs are released. Changed PKG DWG from L48.7x7 to L48.7x7B. Changed PKG DWG in ordering information.
March 9, 2006	FN6209.0	Initial Release.

About Intersil

Intersil Corporation is a leading provider of innovative power management and precision analog solutions. The company's products address some of the largest markets within the industrial and infrastructure, mobile computing and high-end consumer markets.

For the most updated datasheet, application notes, related documentation and related parts, please see the respective product information page found at www.intersil.com.

You may report errors or suggestions for improving this datasheet by visiting www.intersil.com/ask.

Reliability reports are also available from our website at www.intersil.com/support

© Copyright Intersil Americas LLC 2006-2014. All Rights Reserved.

All trademarks and registered trademarks are the property of their respective owners.

For additional products, see www.intersil.com/en/products.html

Intersil products are manufactured, assembled and tested utilizing ISO9001 quality systems as noted in the quality certifications found at www.intersil.com/en/support/qualandreliability.html

Intersil products are sold by description only. Intersil may modify the circuit design and/or specifications of products at any time without notice, provided that such modification does not, in Intersil's sole judgment, affect the form, fit or function of the product. Accordingly, the reader is cautioned to verify that datasheets are current before placing orders. Information furnished by Intersil is believed to be accurate and reliable. However, no responsibility is assumed by Intersil or its subsidiaries for its use; nor for any infringements of patents or other rights of third parties which may result from its use. No license is granted by implication or otherwise under any patent or patent rights of Intersil or its subsidiaries.

For information regarding Intersil Corporation and its products, see www.intersil.com

Looking for pricing, stock, or lifecycle information?

Click below to explore more details on WIN SOURCE:

 [View ISL59482IRZ-T13 on WIN SOURCE](#)

 [Intersil Information](#)

Optimize Your Supply Chain with WIN SOURCE Solutions

-  Global Sourcing Solution
-  Obsolete Management
-  Cost Control Management
-  Shortage Management
-  Alternative Solution
-  Excess Inventory Management