

ISL54233

Wideband Differential 3:1 Multiplexer

FN7918
Rev.1.00
Dec 12, 2018

The [ISL54233](#) is a single supply differential 3 to 1 multiplexer that operates from a single supply in the range of 2.7V to 4.6V. It was designed to multiplex between three different differential data sources, allowing the multiplexing of USB 2.0 high speed data signals, UART data signals and digital video through a common headphone connector in Personal Media Players and other portable battery powered devices.

The switch channels have low ON capacitance and high bandwidth (1.6GHz) to pass USB high speed signals (480Mbps) and digital video signals with minimal edge and phase distortion and can swing rail-to-rail to pass UART and full-speed USB signals.

All channels of the multiplexer can be turned OFF (disabled) by driving the C0 and C1 logic pins to the low state.

The ISL54233 is available in a tiny 12 Ld 2.2mmx1.4mm ultra-thin QFN and 12 Ld 3mmx3mm TQFN package. It operates over a temperature range of -40°C to +85°C.

Related Literature

- Technical Brief [TB363](#) "Guidelines for Handling and Processing Moisture Sensitive Surface Mount Devices (SMDs)"

Features

- High Speed (480Mbps) and Full Speed (12Mbps) Signaling Capability per USB 2.0 on All Ports
- Digital Video Transmission
- COM Pins Allow Negative Swings to -2V
- All Switches OFF Mode
- Power OFF Protection
- COM Pins Overvoltage Tolerant to 5.5V
- Low ON Capacitance @ 240MHz 2.8pF
- -3dB Frequency..... 1.6GHz
- Single Supply Operation (V_{DD}) 2.7V to 4.6V
- Available 12 Ld UTQFN and 12 Ld TQFN Packages
- Compliant with USB 2.0 Short Circuit Requirements Without Additional External Components
- Pb-Free (RoHS Compliant)

Applications

- MP4 and Other Personal Media Players
- Mobile Phone/Smart Phone
- Tablets, Readers, GPS and MHL

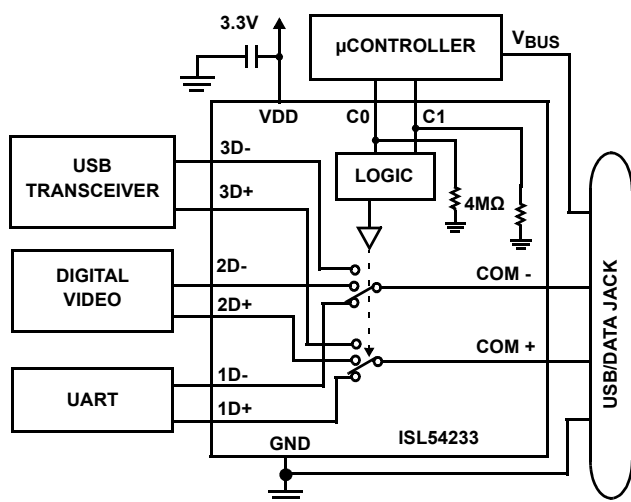

FIGURE 1. TYPICAL APPLICATION

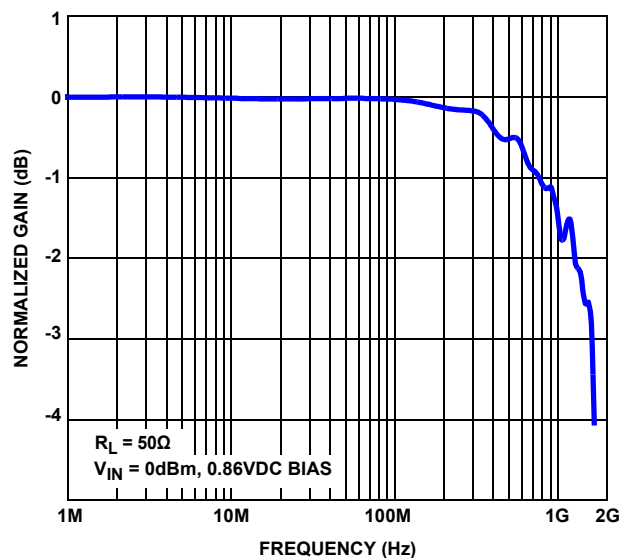
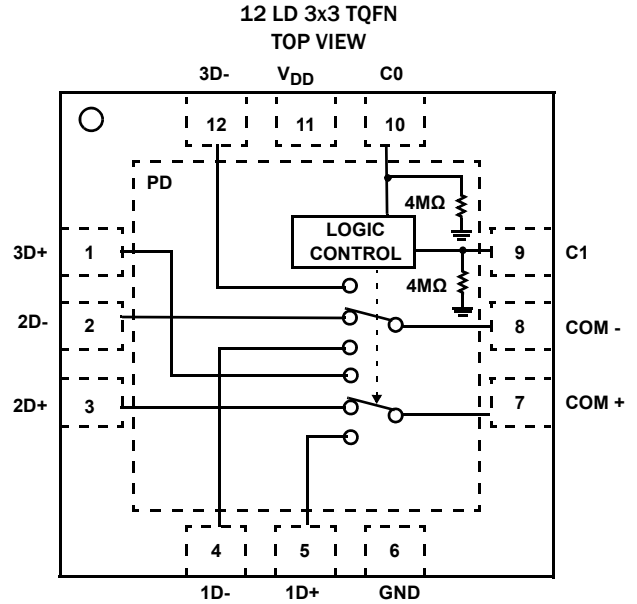
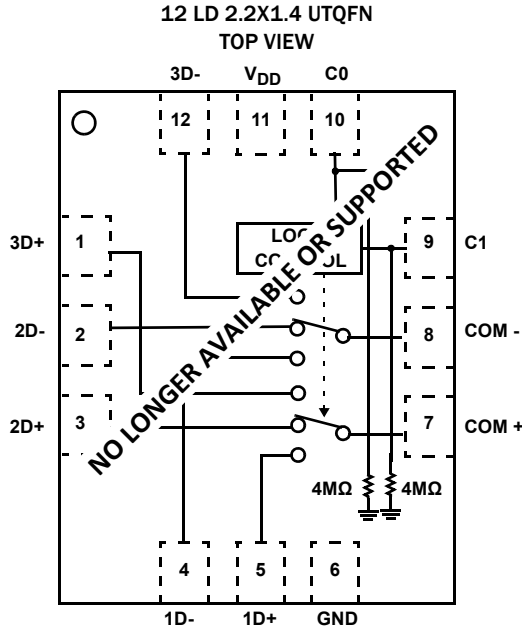

FIGURE 2. BANDWIDTH CHARACTERISTICS CURVE

Pin Configuration



NOTE:

1. ISL54233 switches shown for C1 = Logic "1" and C0 = Logic "0".

Pin Descriptions

UTQFN	TQFN	NAME	FUNCTION
1	1	3D+	USB3/DV Differential Input
2	2	2D-	USB2/DV Differential Input
3	3	2D+	USB2/DV Differential Input
4	4	1D-	USB1/DV Differential Input
5	5	1D+	USB1/DV Differential Input
6	6	GND	Ground Connection
7	7	COM+	Data Common Pin
8	8	COM-	Data Common Pin
9	9	C1	Digital Control Input
10	10	C0	Digital Control Input
11	11	V _{DD}	Power Supply
12	12	3D-	USB3/DV Differential Input
-	PAD	PAD	Thermal Pad. Tie to Ground or Float

Truth Table

C1	C0	MODE	COMMENTS
0	0	Wired-OR Audio	All switches open
0	1	USB/DV #1	1D- and 1D+ ON
1	0	USB/DV #2	2D- and 2D+ ON
1	1	USB/DV #3	3D- and 3D+ ON

C0, C1: Logic "0" when ≤ 0.5V or float, Logic "1" when ≥ 1.4V with V_{DD} in range of 2.7V to 3.6V.

Ordering Information

PART NUMBER	PART MARKING	TEMP. RANGE (°C)	PACKAGE (Pb-Free)	PKG. DWG. #
ISL54233IRUZ-T (Notes 2, 3) (No longer available or supported)	HM	-40 to +85	12 Ld 2.2mmx1.4mm UTQFN (Tape and Reel)	L12.2.2x1.4A
ISL54233IRTZ (Note 4)	4233	-40 to +85	12 Ld 3mmx3mm TQFN	L12.3x3A
ISL54233IRTZ-T (Note 2, 4)	4233	-40 to +85	12 Ld 3mmx3mm TQFN (Tape and Reel)	L12.3x3A

NOTES:

- Please refer to [TB347](#) for details on reel specifications.
- These Pb-free plastic packaged products employ special Pb-free material sets; molding compounds/die attach materials and NiPdAu plate - e4 termination finish, which is RoHS compliant and compatible with both SnPb and Pb-free soldering operations. Pb-free products are MSL classified at Pb-free peak reflow temperatures that meet or exceed the Pb-free requirements of IPC/JEDEC J STD-020.
- These Pb-free plastic packaged products employ special Pb-free material sets, molding compounds/die attach materials, and 100% matte tin plate plus anneal (e3 termination finish, which is RoHS compliant and compatible with both SnPb and Pb-free soldering operations). Pb-free products are MSL classified at Pb-free peak reflow temperatures that meet or exceed the Pb-free requirements of IPC/JEDEC J STD-020.
- For Moisture Sensitivity Level (MSL), please see device information page for [ISL54233](#). For more information on MSL please see techbrief [TB363](#).

Absolute Maximum Ratings

V_{DD} to GND	-0.3V to 5.5V
Input Voltages	
1D+, 1D-, 2D+, 2D-, 3D+, 3D-	-2V to 5.5V
C0, C1 (Note 6)	-0.3V to 5.5V
Output Voltages	
COM-, COM+	-2V to 5.5V
Continuous Current (1D-, 1D+, 2D-, 2D+, 3D-, 3D+)	±40mA
Peak Current (1D-, 1D+, 2D-, 2D+, 3D-, 3D+)	
(Pulsed 1ms, 10% Duty Cycle, Max)	±100mA
ESD Rating:	
Human Body Model (Tested per JESD22-A114F)	>5kV
Machine Model (Tested per JESD22-A115B)	>400V
Charged Device Model (Tested per JESD22-C110D)	>2kV
Latch-up (Tested per JESD-78B; Class 2, Level A)	at +85°C

Thermal Information

Thermal Resistance (Typical)	θ_{JA} (°C/W)	θ_{JC} (°C/W)
12 Ld UTQFN Package (Notes 7, 10)	155	90
12 Ld TQFN Package (Notes 8, 9)	58	1.0
Maximum Junction Temperature (Plastic Package)	+150°C	
Maximum Storage Temperature Range	-65°C to +150°C	
Pb-Free Reflow Profile	see TB493	

Operating Conditions

Temperature Range	-40°C to +85°C
Supply Voltage Range	2.7V to 4.6V

CAUTION: Do not operate at or near the maximum ratings listed for extended periods of time. Exposure to such conditions may adversely impact product reliability and result in failures not covered by warranty.

NOTES:

- Signals on C1 and C0 exceeding GND by specified amount are clamped. Limit current to maximum current ratings.
- θ_{JA} is measured with the component mounted on a high effective thermal conductivity test board in free air. See Tech Brief [TB379](#) for details.
- θ_{JA} is measured in free air with the component mounted on a high effective thermal conductivity test board with "direct attach" features. See Tech Brief [TB379](#).
- For θ_{JC} , the "case temp" location is the center of the exposed metal pad on the package underside.
- For θ_{JC} , the "case temp" location is taken at the package top center.

Electrical Specifications - 2.7V to 3.6V Supply Test Conditions: $V_{DD} = +3.0V$, $GND = 0V$, V_{COH} , $V_{C1H} = 1.4V$, V_{C0L} , $V_{C1L} = 0.5V$, (Note 11), **Unless Otherwise Specified. Boldface limits apply over the operating temperature range, -40°C to +85°C.**

PARAMETER	TEST CONDITIONS	TEMP (°C)	MIN (Notes 12, 13)	TYP	MAX (Notes 12, 13)	UNITS
ANALOG SWITCH CHARACTERISTICS						
Analog Signal Range, V_{ANALOG}	$V_{DD} = 2.7V$ to 4.6V	Full	-1	-	V_{DD}	V
ON-Resistance, r_{ON}	$V_{DD} = 2.7V$, $I_{COMx} = 17mA$, V_{D+} or $V_{D-} = 0V$ to 400mV (see Figure 5, Note 15)	25	-	6	8	Ω
r_{ON} Matching Between Channels, Δr_{ON}	$V_{DD} = 2.7V$, $I_{COMx} = 17mA$, V_{D+} or $V_{D-} =$ Voltage at max r_{ON} , (Notes 15, 16)	25	-	0.07	0.5	Ω
		Full	-	-	0.55	Ω
r_{ON} Flatness, $r_{FLAT(ON)}$	$V_{DD} = 2.7V$, $I_{COMx} = 17mA$, V_{D+} or $V_{D-} = 0V$ to 400mV, (Notes 14, 15)	25	-	0.32	0.8	Ω
		Full	-	-	1.2	Ω
ON-Resistance, r_{ON}	$V_{DD} = 3.3V$, $I_{COMx} = 17mA$, V_{D+} or $V_{D-} = 3.3V$ (see Figure 5, Note 15)	+25	-	9.5	15	Ω
		Full	-	-	20	Ω
OFF Leakage Current, $I_{XD+(OFF)}$ or $I_{XD-(OFF)}$, $I_{COMX(OFF)}$	$V_{DD} = 4.6V$, All OFF Mode (C0 = 0.5V, C1 = 0.5V), V_{COM-} or $V_{COM+} = 0.3V$, 3.3V, V_{XD+} or $V_{XD-} = 3.3V$, 0.3V	25	-15	-	15	nA
		Full	-20	-	20	nA
ON Leakage Current, $I_{XD+(ON)}$ or $I_{XD-(ON)}$, $I_{COMX(ON)}$	$V_{DD} = 4.6V$, V_{XD+} or $V_{XD-} = 0.3V$, 3.3V, V_{COM-} or $V_{COM+} = 0.3V$, 3.3V	25	-20	-	20	nA
		Full	-25	-	25	nA
DPDT DYNAMIC CHARACTERISTICS						
All OFF to ON or ON to All OFF Address Transition Time, t_{TRANS}	$V_{DD} = 2.7V$, $R_L = 50\Omega$, $C_L = 10pF$, (see Figure 3)	25	-	125	-	ns
Data Channel to Data Channel Address Transition Time, t_{TRANS}	$V_{DD} = 2.7V$, $R_L = 50\Omega$, $C_L = 10pF$, (see Figure 3)	25	-	125	-	ns
Break-Before-Make Time Delay, t_D	$V_{DD} = 3.6V$, $R_L = 50\Omega$, $C_L = 10pF$, (see Figure 4)	25	-	30	-	ns
Skew, ($t_{SKEWOUT} - t_{SKEWIN}$)	$V_{DD} = 3.0V$, $R_L = 45\Omega$, $C_L = 10pF$, $t_R = t_F = 500ps$ at 480Mbps, (Duty Cycle = 50%) (see Figure 8)	25	-	75	-	ps
Total Jitter, t_j	$V_{DD} = 3.0V$, $R_L = 50\Omega$, $C_L = 10pF$, $t_R = t_F = 500ps$ at 480Mbps	25	-	210	-	ps

Electrical Specifications - 2.7V to 3.6V Supply Test Conditions: $V_{DD} = +3.0V$, $GND = 0V$, V_{COH} , $V_{C1H} = 1.4V$, V_{COL} , $V_{C1L} = 0.5V$, (Note 11), Unless Otherwise Specified. Boldface limits apply over the operating temperature range, $-40^{\circ}C$ to $+85^{\circ}C$. (Continued)

PARAMETER	TEST CONDITIONS	TEMP (°C)	MIN (Notes 12, 13)	TYP	MAX (Notes 12, 13)	UNITS
Rise/Fall Degradation (Propagation Delay), t_{PD}	$V_{DD} = 3.0V$, $R_L = 45\Omega$, $C_L = 10pF$, (see Figure 8)	25	-	250	-	ps
Crosstalk	$V_{DD} = 3.0V$, $R_L = 50\Omega$, $f = 240MHz$	25	-	-36	-	dB
OFF-Isolation	$V_{DD} = 3.0V$, $R_L = 50\Omega$, $f = 240MHz$	25	-	-32	-	dB
-3dB Bandwidth	Signal = 0dBm, 0.2VDC offset, $R_L = 50\Omega$	25	-	1.6	-	GHz
OFF Capacitance, C_{XD+OFF} , C_{XD-OFF}	$f = 1MHz$, $V_{DD} = 3.0V$ (see Figure 6)	25	-	3	-	pF
COM ON Capacitance, $C_{COM-(ON)}$, $C_{COM+(ON)}$	$f = 1MHz$, $V_{DD} = 3.0V$ (see Figure 6)	25	-	6	-	pF
COM ON Capacitance, $C_{COM-(ON)}$, $C_{COM+(ON)}$	$f = 240MHz$, $V_{DD} = 3.0V$	25	-	2.8	-	pF
POWER SUPPLY CHARACTERISTICS						
Power Supply Range, V_{DD}		Full	2.7		4.6	V
Positive Supply Current, I_{DD} (ALL OFF Mode)	$V_{DD} = 3.6V$, $C1 = GND$, $C0 = GND$	25	-	6.5	8	μA
		Full	-	-	15	μA
Positive Supply Current, I_{DD} (USB1 Mode)	$V_{DD} = 3.6V$, $C1 = GND$, $C0 = V_{DD}$	25	-	6.5	8	μA
		Full	-	-	15	μA
Positive Supply Current, I_{DD} (USB2 Mode)	$V_{DD} = 3.6V$, $C1 = V_{DD}$, $C0 = GND$	25	-	6.5	8	μA
		Full	-	-	15	μA
Positive Supply Current, I_{DD} (USB3 Mode)	$V_{DD} = 3.6V$, $C0 = C1 = V_{DD}$	25	-	6.5	8	μA
		Full	-	-	15	μA
Power OFF COMx Current, I_{COMx}	$V_{DD} = 0V$, $C0 = C1 = Float$, $COMx = 5.25V$	25	-	-	1	μA
Power OFF Logic Current, I_{C0} , I_{C1}	$V_{DD} = 0V$, $C0 = C1 = 5.25V$	25	-	11	-	μA
Power OFF D+/D- Current, I_{XD+} , I_{XD-}	$V_{DD} = 0V$, $C0 = C1 = Float$, $XD- = XD+ = 5.25V$	25	-	5	-	μA
DIGITAL INPUT CHARACTERISTICS						
C0, C1 Voltage Low, V_{COL} , V_{C1L}	$V_{DD} = 2.7V$ to $3.6V$	Full	-	-	0.5	V
C0, C1 Voltage High, V_{COH} , V_{C1H}	$V_{DD} = 2.7V$ to $3.6V$	Full	1.4	-	5.25	V
C0, C1 Input Current, I_{C0L} , I_{C1L}	$V_{DD} = 3.6V$, $C0 = C1 = 0V$ or Float	Full	-50	6.2	50	nA
C0, C1 Input Current, I_{C0H} , I_{C1H}	$V_{DD} = 3.6V$, $C0 = C1 = 3.6V$	Full	-2	1.6	2	μA
C0, C1 Pull-Down Resistor, R_{Cx}	$V_{DD} = 3.6V$, $C0 = C1 = 3.6V$, Measure current into C0 or C1 pin and calculate resistance value.	Full	-	4	-	M Ω

NOTES:

- V_{logic} = Input voltage to perform proper function.
- The algebraic convention, whereby the most negative value is a minimum and the most positive a maximum, is used in this data sheet.
- Parameters with MIN and/or MAX limits are 100% tested at $+25^{\circ}C$, unless otherwise specified. Temperature limits established by characterization and are not production tested.
- Flatness is defined as the difference between maximum and minimum value of ON-resistance over the specified analog signal range.
- Limits established by characterization and are not production tested.
- r_{ON} matching between channels is calculated by subtracting the channel with the highest max r_{ON} value from the channel with lowest max r_{ON} value, between 1D+ and 1D- or between 2D+ and 2D- or between 3D+ and 3D-.

Test Circuits and Waveforms

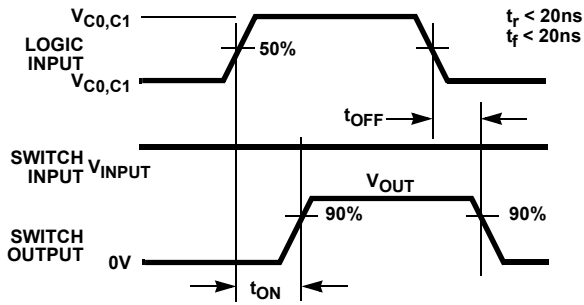

Logic input waveform is inverted for switches that have the opposite logic sense.

FIGURE 3A. ADDRESS t_{TRANS} MEASUREMENT POINTS

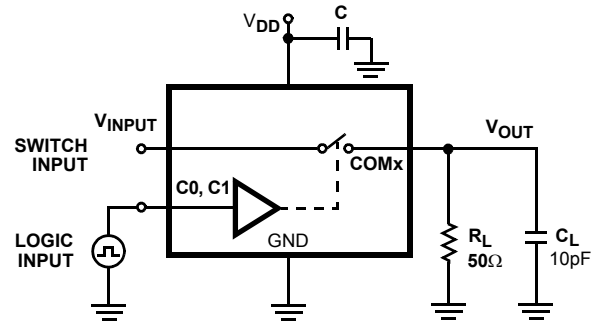

Repeat test for all switches. C_L includes fixture and stray capacitance.

$$V_{\text{OUT}} = V_{\text{(INPUT)}} \frac{R_L}{R_L + r_{\text{ON}}}$$

FIGURE 3B. ADDRESS t_{TRANS} TEST CIRCUIT

FIGURE 3. SWITCHING TIMES

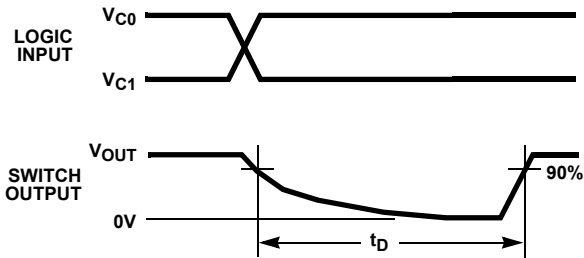
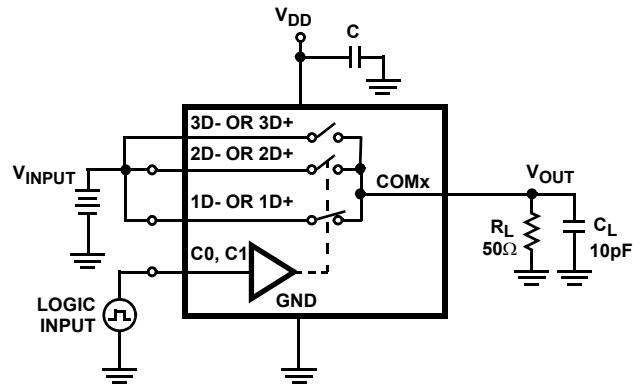

FIGURE 4A. MEASUREMENT POINTS



Repeat test for all switches. C_L includes fixture and stray capacitance.

FIGURE 4B. TEST CIRCUIT

FIGURE 4. BREAK-BEFORE-MAKE TIME

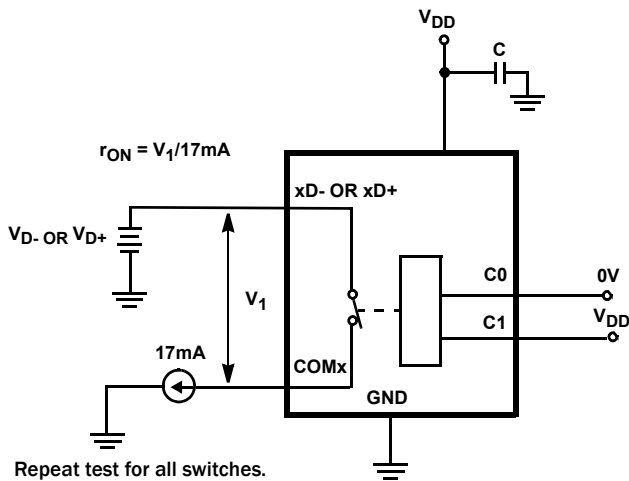

Repeat test for all switches.

FIGURE 5. r_{ON} TEST CIRCUIT

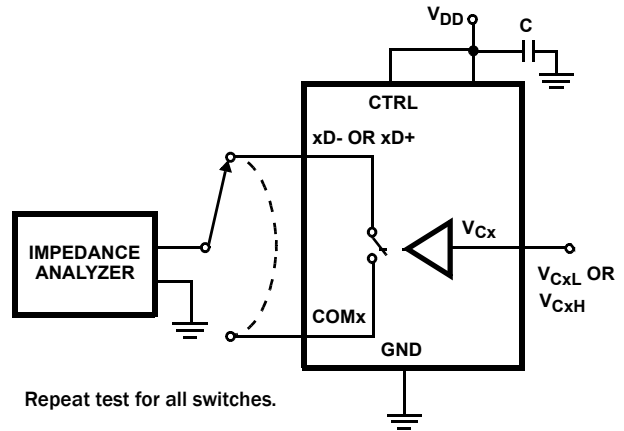

Repeat test for all switches.

FIGURE 6. CAPACITANCE TEST CIRCUIT

Test Circuits and Waveforms (Continued)

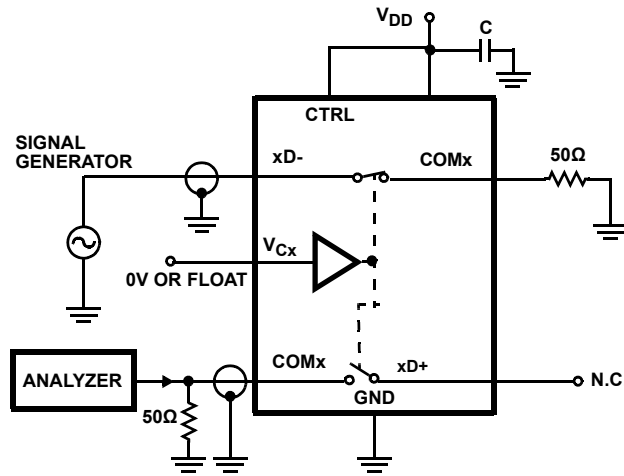

FIGURE 7. CROSTALK TEST CIRCUIT

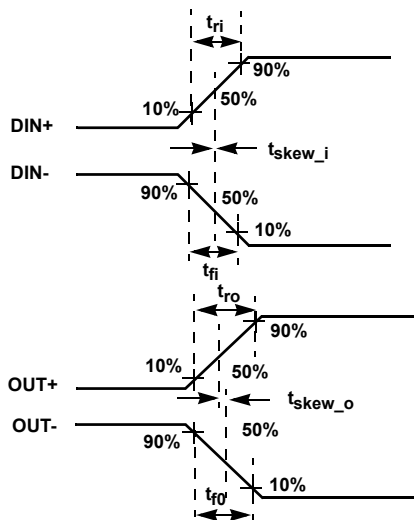
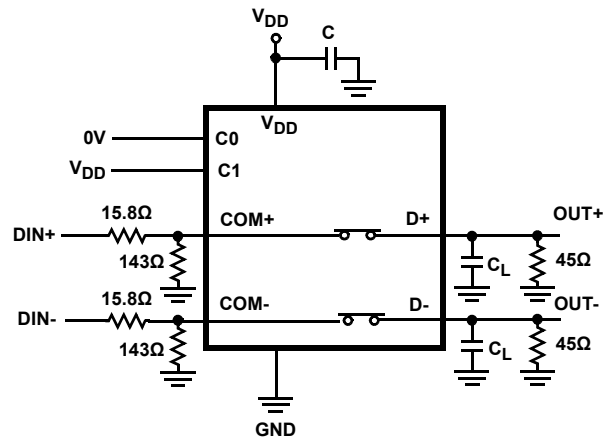

FIGURE 8A. MEASUREMENT POINTS



$|t_{ro} - t_{ri}|$ Delay Due to Switch for Rising Input and Rising Output Signals
 $|t_{fo} - t_{fi}|$ Delay Due to Switch for Falling Input and Falling Output Signals
 $|t_{skew_o}|$ Change in Skew through the Switch for Output Signals
 $|t_{skew_i}|$ Change in Skew through the Switch for Input Signals

FIGURE 8B. TEST CIRCUIT

FIGURE 8. SKEW TEST

Application Block Diagram

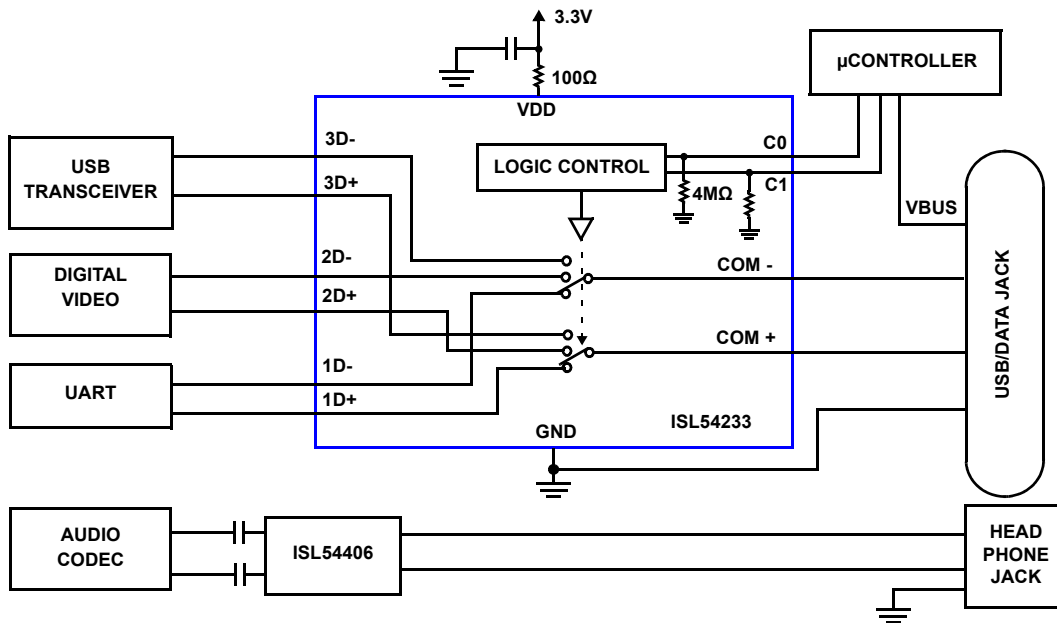

Detailed Description

The ISL54233 device consists of dual SP3T (single pole/triple throw) analog switches. It operates from a single DC power supply in the range of 2.7V to 4.6V. It was designed to function as a differential 3 to 1 multiplexer to select between three different differential data signals. It is offered in tiny UTQFN and TQFN packages for use in MP3 players, PDAs, cellphones, and other personal media players.

The device consists of six 6Ω data switches. It was designed to pass high-speed USB differential data and digital video signals with minimal edge and phase distortion. It can swing rail-to-rail to pass UART and full-speed USB signals.

The COM pins can accept signals that swing below ground by as much as -2V. This allows an audio source to be wired-OR connected at the COM pins.

The ISL54233 was specifically designed for MP3 players, personal media players and cellphone applications that need to combine three differential data channels into a single shared connector, thereby saving space and component cost. This functionality is shown in the Typical Application Block Diagram on page 1.

A detailed description of the switches is provided in the following sections.

Data Switches

The six data switches (1D+, 1D-, 2D+, 2D-, 3D+, 3D-) are 6Ω bidirectional switches that were specifically designed to pass high-speed USB differential data signals in the range of 0V to 400mV. The switches have low capacitance and high bandwidth to pass USB high-speed signals (480Mbps) with minimum edge and phase distortion to meet USB 2.0 signal quality specifications. See Figures 15 and 16 for high-speed Eye Pattern taken with the switch in the signal path.

These switches can also swing rail-to-rail and pass USB full-speed (12Mbps) and UART signals with minimal distortion. See Figure 17 for USB full-speed Eye Pattern taken with the switch in the signal path.

The maximum normal operating signal range for the USB switches is from -1V to V_{DD} . The signal voltage at D- and D+ should not be allowed to exceed the V_{DD} voltage rail or go below ground by more than -1V for normal operation.

Fault Protection and Power-Off Protection

However, in the event that the USB 5.25V V_{BUS} voltage were shorted to one or both of the COM pins, the ISL54233 has fault protection circuitry to prevent damage to the ISL54233 part. The fault circuitry allows the signal pins (COM-, COM+, 1D-, 1D+, 2D-, 2D+, 3D-, 3D+) to be driven up to 5.25V while the V_{DD} supply voltage is in the range of 0V to 4.6V. This fault condition causes no stress to the IC.

In addition, when V_{DD} is at 0V (ground) all switches are OFF and the fault voltage is isolated from the other side of the switch (Power-Off Protection).

When V_{DD} is in the range of 2.7V to 4.6V, the fault voltage will pass through to the output of an active switch channel. Note: During the fault condition, normal operation is not guaranteed until the fault condition is removed.

ISL54233 Operation

The discussion that follows will discuss using the ISL54233 in the "Application Block Diagram" on page 8.

POWER

The power supply connected at V_{DD} (pin 11) provides power to the ISL54233 part. Its voltage should be kept in the range of 2.7V to 4.6V. In a typical application, V_{DD} will be in the range of 2.7V to 4.3V and will be connected to the battery or LDO of the MP3 player or cellphone.

A 0.01 μ F or 0.1 μ F decoupling capacitor should be connected from the V_{DD} pin to ground to filter out any power supply noise from entering the part. The capacitor should be located as close to the V_{DD} pin as possible.

LOGIC CONTROL

The state of the ISL54233 device is determined by the voltage at the C1 pin (pin 9) and the C0 pin (pin 10). Refer to the "Truth Table" on page 2.

The C1 pin and C0 pin are internally pulled low through 4M Ω resistors to ground and can be tri-stated or left floating.

The C1 pin and C0 pin can be driven with a voltage that is higher than the V_{DD} supply voltage. They can be driven up to 5.25V with the V_{DD} supply in the range of 2.7V to 4.6V. Driving the logic higher than the supply rail will cause the logic current to increase. With $V_{DD} = 2.7V$ and $V_{LOGIC} = 5.25V$, I_{LOGIC} current is approximately 5.5 μ A.

Logic Control Voltage Levels

With V_{DD} in the range of 2.7V to 3.6V the logic levels are: C1, C0 = Logic "0" (Low) when $\leq 0.5V$ or Floating. C1, C0 = Logic "1" (High) when $\geq 1.4V$.

ALL SWITCHES OFF Mode

If the C1 pin = Logic "0" and C0 pin = Logic "0" the part will be in the ALL SWITCHES OFF mode. In this mode, the 3D- and 3D+ data switches, the 2D- and 2D+ data switches, and the 1D- and 1D+ data switches will be OFF (high impedance).

The COM pins can accommodate signals that swing below ground by as much as -2V. This allows an audio CODEC to be connected to the COM pins when the device is in the all off state.

USB/DV 1 Mode

If the C1 pin = Logic "0" and C0 pin = Logic "1" the part will go into USB/DV1 mode. The 1D- and 1D+ switches are ON and the 2D- and 2D+ switches and 3D- and 3D+ will be OFF (high impedance).

USB/DV 2 Mode

If the C1 = Logic "1" and C0 pin = Logic "0" the part will be in the USB/DV2 mode. The 2D- and 2D+ switches will be ON and the 1D- and 1D+ switches and the 3D- and 3D+ will be OFF (high impedance).

USB/DV 3 Mode

If the C1 pin = Logic "1" and C0 pin = Logic "1" the part will be in the USB/DV3 mode. The 3D- and 3D+ switches are ON, and the 1D- and 1D+ switches and 2D- and 2D+ switches will be OFF (high impedance).

Printed Circuit Board Design for High Frequency Performance

In 50 Ω systems, the ISL54233 has a -3dB bandwidth of 1.6GHz (see Figure 19).

To achieve this high bandwidth requires careful design and layout of the PCB board. Signal traces must be designed to minimize reflections and reduce parasitic resistance, inductance and capacitance that degrade the frequency response performance.

Figure 9 shows a picture of the engineering board used to measure the frequency response of the ISL54233 part. The board was specifically design for taking high frequency bandwidth measurements. The board was made with special materials and was carefully layed out using RF board techniques to maximize it for high frequency operation.

The next section, "Board Layout Guidelines", will provide a list of the PCB board requirements needed to get the maximum bandwidth from the ISL54233 part when tested with a 50 Ω Network Analyzer.

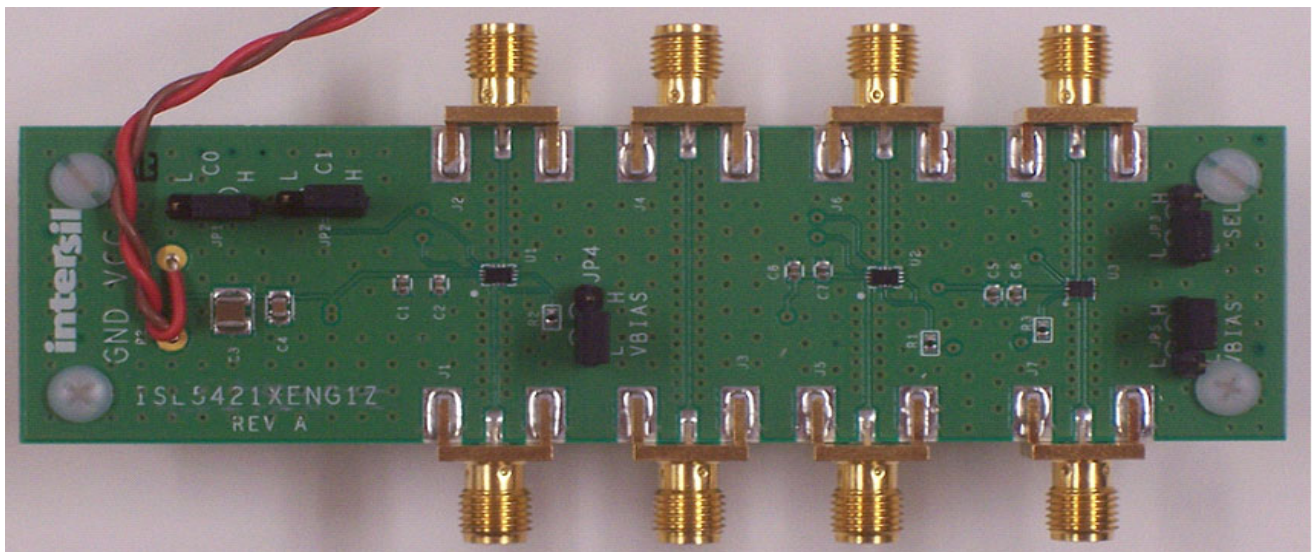

FIGURE 9. RF HIGH FREQUENCY BOARD

BOARD LAYOUT GUIDELINES

- The ISL54233 device must be soldered directly onto the PCB board. No IC sockets can be used. Their parasitic impedance will degrade the frequency performance.
- The signal traces (1D+, 1D-, 2D+, 2D-, 3D+, 3D-, COM- and COM+) must have a controlled (characteristic) impedance of $50\Omega \pm 5\%$. Tight control on trace width and dielectric thickness must be followed to get 50Ω lines. Impedance tests results for controlled lines should be requested from the board fabrication house.
- A four layer PCB board: Signal (top layer), Thin-Dielectric, GND (2nd layer), Thick-Dielectric, GND (3rd layer), Thin-Dielectric, Signal (Bottom layer) is required to achieve 50Ω traces. The top and bottom thin-dielectric are Nelco 4000-13 or Rogers 4350 core type material. The center thick-dielectric is FR4 pre-preg material. Figure 10 illustrates the material and sequencing of the layers. The dimensions called out are those required to achieve 50Ω microstrip for the signal traces.

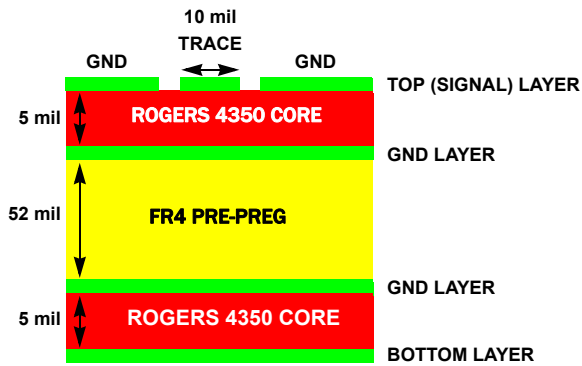

FIGURE 10. FOUR LAYER BOARD STACK-UP

- Route all controlled impedance signal lines on the top (signal) layer with no vias or through holes. Vias or through holes make it difficult to maintain a controlled impedance and tend to generate reflections.
- The signal trace lengths should be as short (<1 inch from SMA connector to the switch pin) and straight as possible. If it becomes necessary to turn 90° , use two 45° turns or an arc instead of making a single 90° turn. This reduces reflections on the signal by minimizing impedance discontinuities.
- Use Edge - Launch SMA connectors for all signal lines. The SMA connector terminal should be tapered to the signal trace.
- Ground stitching should be done along signal traces and around SMA ground connectors. This helps to isolate the trace in a ground conduit. This reduces capacitive coupling between traces and provides a good return path for the signal.
- Use dry film solder mask. Clear the solder mask from signal trace.
- Power and/or logic lines can be run on the bottom layer. Logic lines should be routed away from the signal lines. This will minimize capacitive coupling from the logic lines.
- A $4.7\mu\text{F}$ capacitor is placed from V_{CC} to GND where the power is brought onto the board. It keeps any low frequency noise from getting on the board. Since a bulk capacitor will look inductive at higher frequencies, an additional $0.1\mu\text{F}$ capacitor is placed across the supply lines. A $0.01\mu\text{F}$ decoupling capacitor needs to be connected from the V_{DD} pin to ground of the ISL54233 part to filter out any power supply noise from entering the part. The capacitor should be a RF type chip capacitor and should be located as close to the V_{DD} pin as possible. Note: RF type capacitors have a smaller foot-print than regular capacitors.

Typical Performance Curves $T_A = +25^\circ\text{C}$, Unless Otherwise Specified.

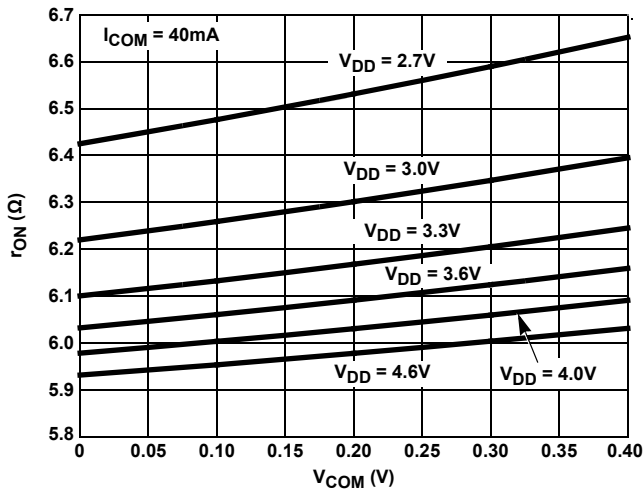

FIGURE 11. ON-RESISTANCE vs SUPPLY VOLTAGE vs SWITCH VOLTAGE

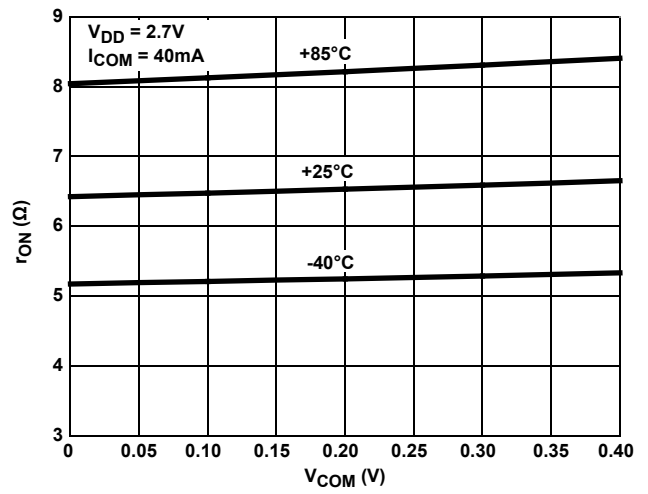

FIGURE 12. ON-RESISTANCE vs SWITCH VOLTAGE vs TEMPERATURE

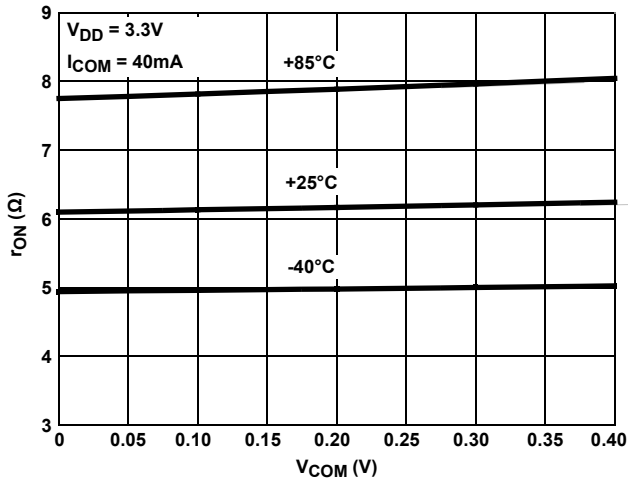

FIGURE 13. ON-RESISTANCE vs SWITCH VOLTAGE vs TEMPERATURE

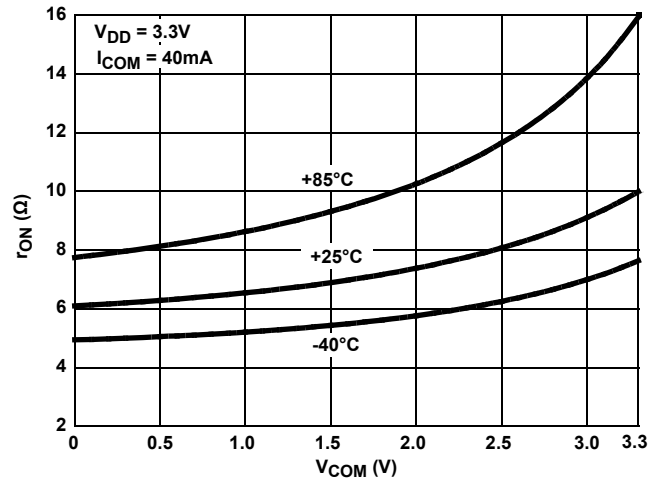

FIGURE 14. ON-RESISTANCE vs SWITCH VOLTAGE vs TEMPERATURE

Typical Performance Curves $T_A = +25^\circ\text{C}$, Unless Otherwise Specified. (Continued)

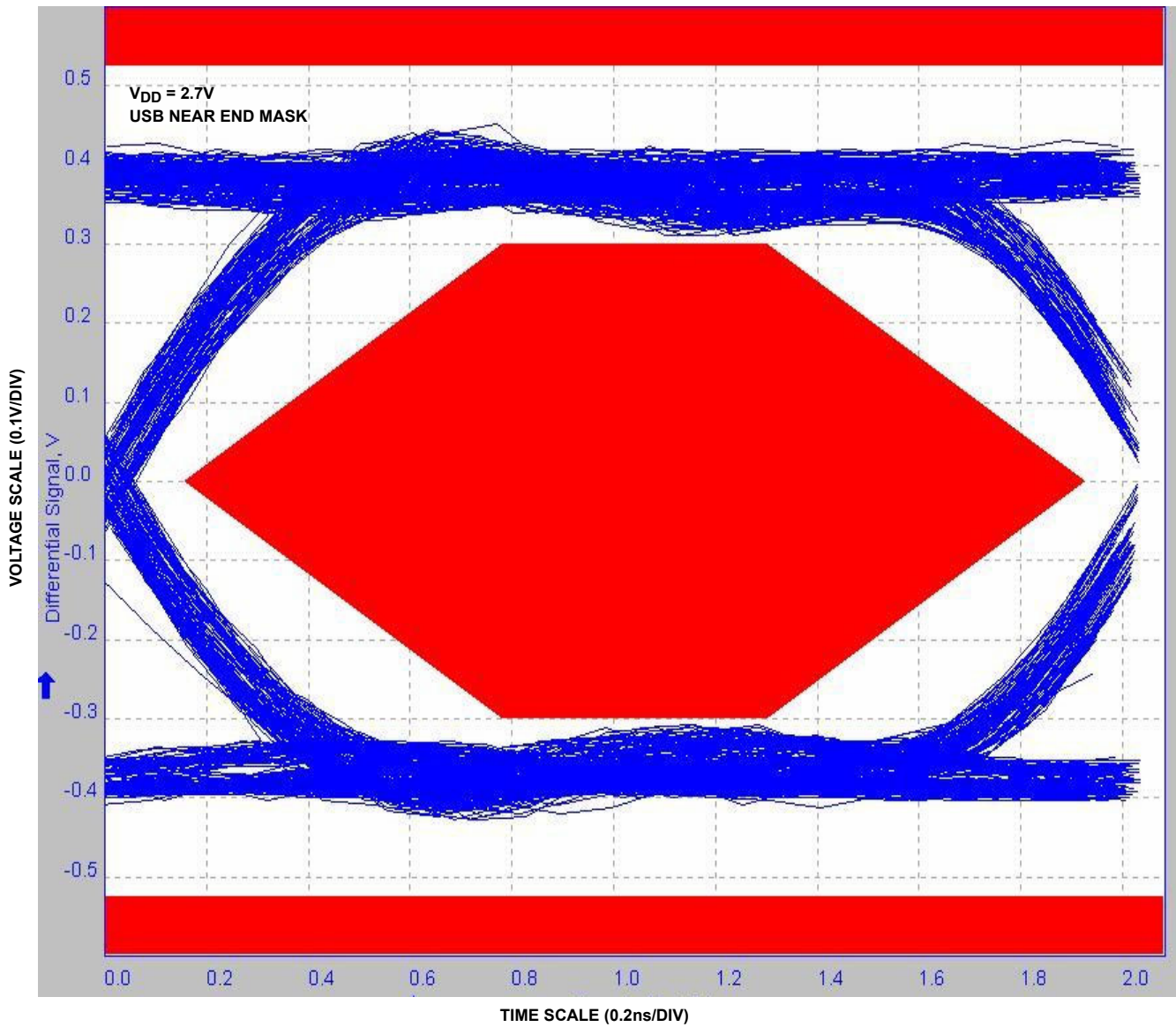

FIGURE 15. EYE PATTERN: 480Mbps WITH USB SWITCHES IN THE SIGNAL PATH

Typical Performance Curves $T_A = +25^\circ\text{C}$, Unless Otherwise Specified. (Continued)

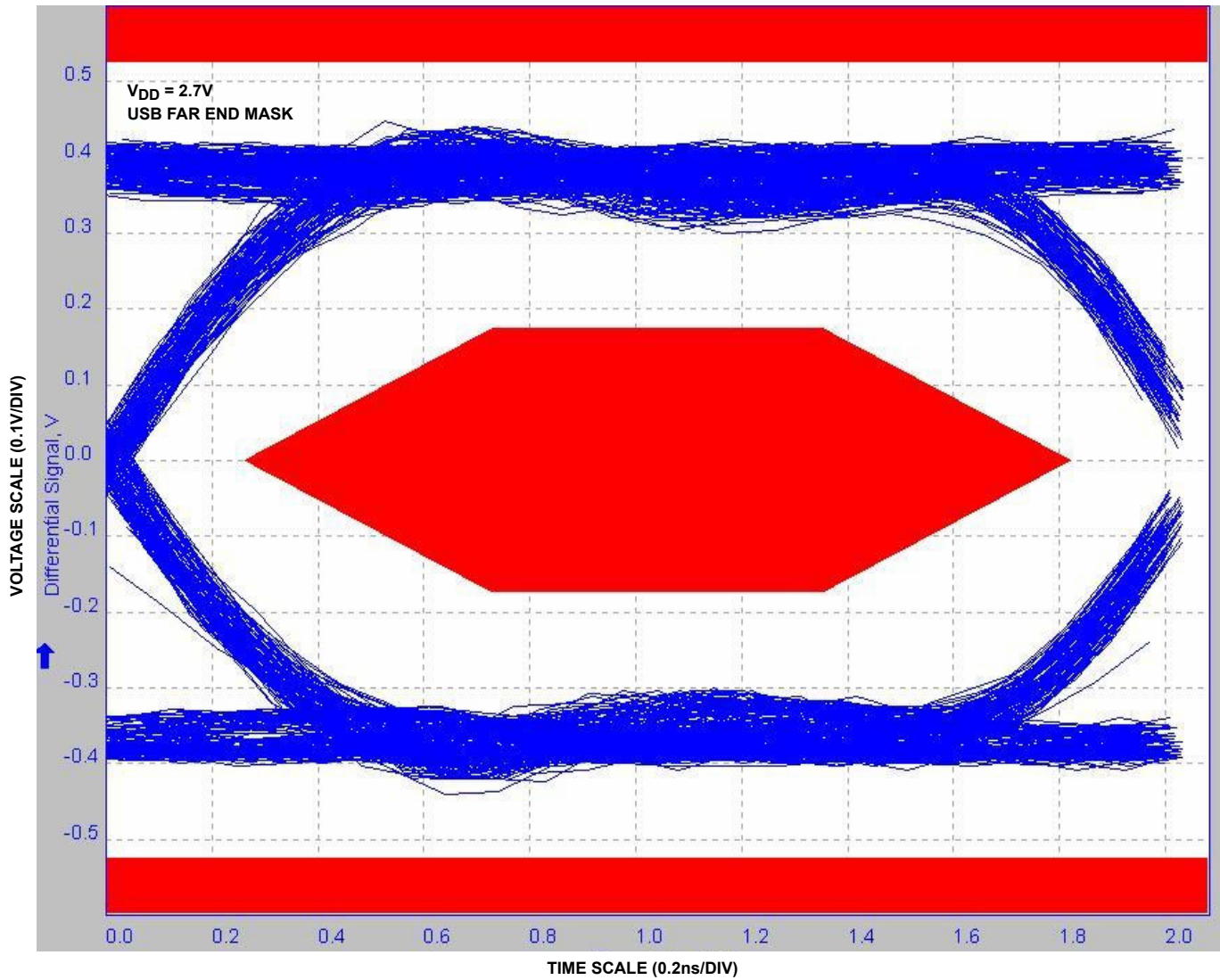

FIGURE 16. EYE PATTERN: 480Mbps WITH USB SWITCHES IN THE SIGNAL PATH

Typical Performance Curves $T_A = +25^\circ\text{C}$, Unless Otherwise Specified. (Continued)

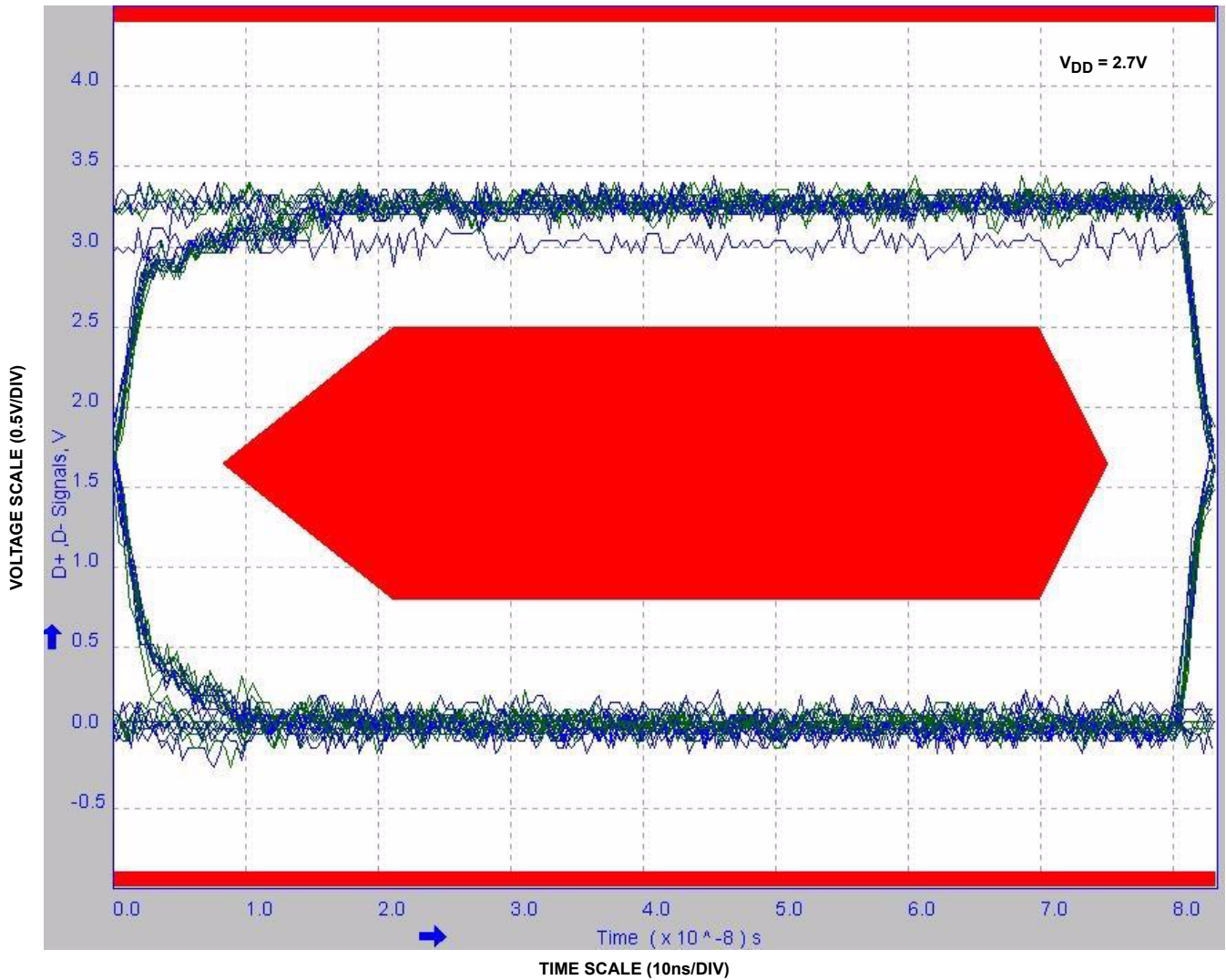

FIGURE 17. EYE PATTERN: 12Mbps USB SIGNAL WITH USB SWITCHES IN THE SIGNAL PATH

Typical Performance Curves $T_A = +25^\circ\text{C}$, Unless Otherwise Specified. (Continued)

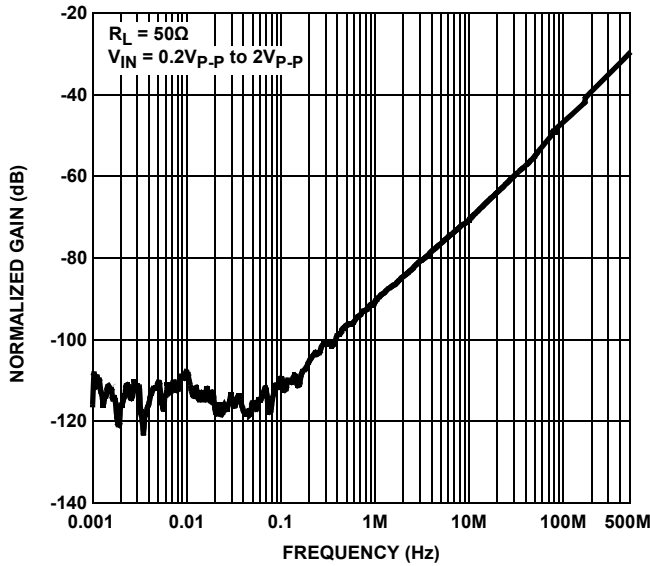

FIGURE 18. OFF-ISOLATION USB SWITCHES

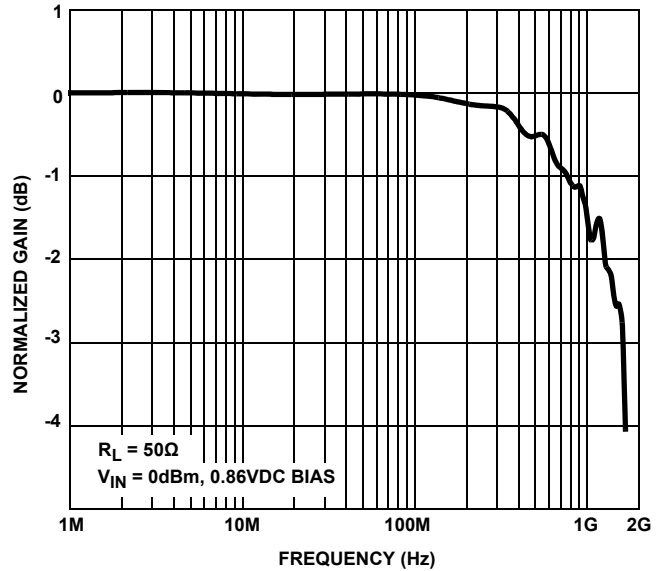

FIGURE 19. FREQUENCY RESPONSE

Die Characteristics

SUBSTRATE AND TQFN THERMAL PAD POTENTIAL (POWERED UP):

GND

TRANSISTOR COUNT:

837

PROCESS:

Submicron CMOS

Revision History

DATE	REVISION	CHANGE
Dec 12, 2018	FN7918.1	Updated ordering information table. Removed Products section. Updated disclaimer.
Dec 21, 2011	FN7918.0	Initial Release.

Package Outline Drawings

For the most recent package outline drawing, see [L12.3x3A](#).

L12.3x3A

12 LEAD THIN QUAD FLAT NO LEAD PLASTIC PACKAGE

Rev 0, 09/07

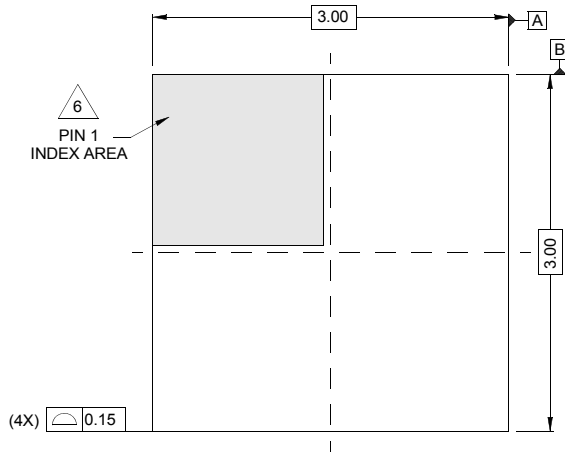

TOP VIEW

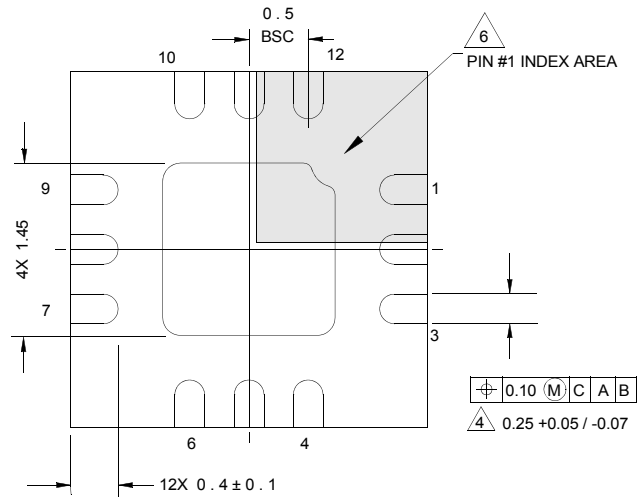

BOTTOM VIEW

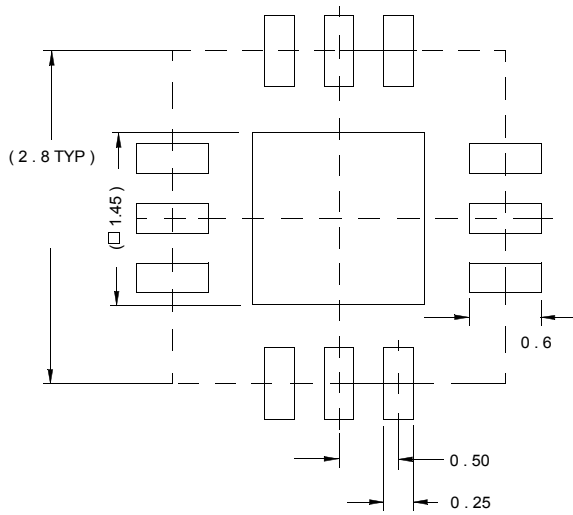

TYPICAL RECOMMENDED LAND PATTERN

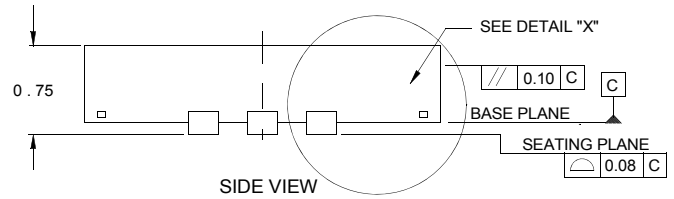

SIDE VIEW

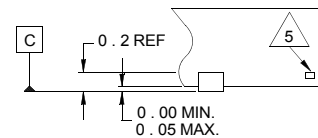

DETAIL "X"

NOTES:

1. Dimensions are in millimeters.
Dimensions in () for Reference Only.
2. Dimensioning and tolerancing conform to AMSE Y14.5m-1994.
3. Unless otherwise specified, tolerance : Decimal ± 0.05
4. Dimension b applies to the metallized terminal and is measured between 0.18mm and 0.30mm from the terminal tip.
5. Tiebar shown (if present) is a non-functional feature.
6. The configuration of the pin #1 identifier is optional, but must be located within the zone indicated. The pin #1 identifier may be either a mold or mark feature.

L12.2.2x1.4A

12 LEAD ULTRA THIN QUAD FLAT NO-LEAD PLASTIC PACKAGE (UTQFN)

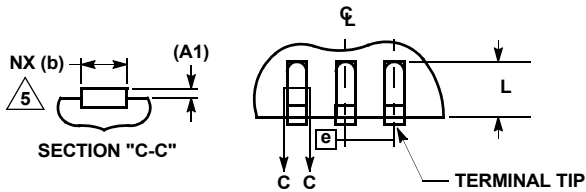
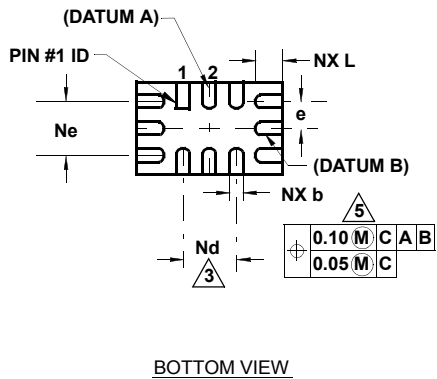
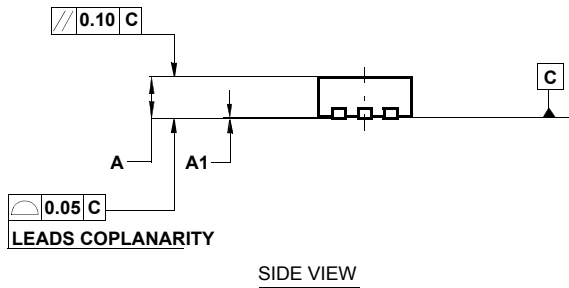
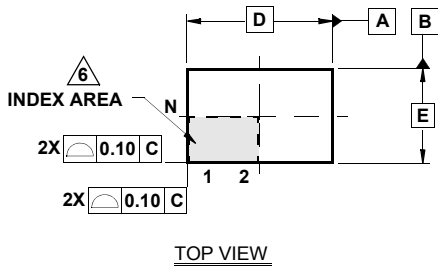

SYMBOL	MILLIMETERS			NOTES
	MIN	NOMINAL	MAX	
A	0.45	0.50	0.55	-
A1	-	-	0.05	-
A3	0.127 REF			-
b	0.15	0.20	0.25	5
D	2.15	2.20	2.25	-
E	1.35	1.40	1.45	-
e	0.40 BSC			-
k	0.20	-	-	-
L	0.35	0.40	0.45	-
N	12			2
Nd	3			3
Ne	3			3
θ	0	-	12	4

Rev. 0 12/06

NOTES:

1. Dimensioning and tolerancing conform to ASME Y14.5-1994.
2. N is the number of terminals.
3. Nd and Ne refer to the number of terminals on D and E side, respectively.
4. All dimensions are in millimeters. Angles are in degrees.
5. Dimension b applies to the metallized terminal and is measured between 0.15mm and 0.30mm from the terminal tip.
6. The configuration of the pin #1 identifier is optional, but must be located within the zone indicated. The pin #1 identifier may be either a mold or mark feature.
7. Maximum package warpage is 0.05mm.
8. Maximum allowable burrs is 0.076mm in all directions.
9. Same as JEDEC MO-255UABD except:
No lead-pull-back, "A" MIN dimension = 0.45 not 0.50mm
"L" MAX dimension = 0.45 not 0.42mm.
10. For additional information, to assist with the PCB Land Pattern Design effort, see Intersil Technical Brief TB389.

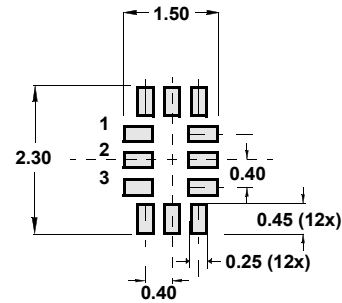

Notice

1. Descriptions of circuits, software and other related information in this document are provided only to illustrate the operation of semiconductor products and application examples. You are fully responsible for the incorporation or any other use of the circuits, software, and information in the design of your product or system. Renesas Electronics disclaims any and all liability for any losses and damages incurred by you or third parties arising from the use of these circuits, software, or information.
2. Renesas Electronics hereby expressly disclaims any warranties against and liability for infringement or any other claims involving patents, copyrights, or other intellectual property rights of third parties, by or arising from the use of Renesas Electronics products or technical information described in this document, including but not limited to, the product data, drawings, charts, programs, algorithms, and application examples.
3. No license, express, implied or otherwise, is granted hereby under any patents, copyrights or other intellectual property rights of Renesas Electronics or others.
4. You shall not alter, modify, copy, or reverse engineer any Renesas Electronics product, whether in whole or in part. Renesas Electronics disclaims any and all liability for any losses or damages incurred by you or third parties arising from such alteration, modification, copying or reverse engineering.
5. Renesas Electronics products are classified according to the following two quality grades: "Standard" and "High Quality". The intended applications for each Renesas Electronics product depends on the product's quality grade, as indicated below.
"Standard": Computers; office equipment; communications equipment; test and measurement equipment; audio and visual equipment; home electronic appliances; machine tools; personal electronic equipment; industrial robots; etc.
"High Quality": Transportation equipment (automobiles, trains, ships, etc.); traffic control (traffic lights); large-scale communication equipment; key financial terminal systems; safety control equipment; etc.
Unless expressly designated as a high reliability product or a product for harsh environments in a Renesas Electronics data sheet or other Renesas Electronics document, Renesas Electronics products are not intended or authorized for use in products or systems that may pose a direct threat to human life or bodily injury (artificial life support devices or systems; surgical implantations; etc.), or may cause serious property damage (space system; undersea repeaters; nuclear power control systems; aircraft control systems; key plant systems; military equipment; etc.). Renesas Electronics disclaims any and all liability for any damages or losses incurred by you or any third parties arising from the use of any Renesas Electronics product that is inconsistent with any Renesas Electronics data sheet, user's manual or other Renesas Electronics document.
6. When using Renesas Electronics products, refer to the latest product information (data sheets, user's manuals, application notes, "General Notes for Handling and Using Semiconductor Devices" in the reliability handbook, etc.), and ensure that usage conditions are within the ranges specified by Renesas Electronics with respect to maximum ratings, operating power supply voltage range, heat dissipation characteristics, installation, etc. Renesas Electronics disclaims any and all liability for any malfunctions, failure or accident arising out of the use of Renesas Electronics products outside of such specified ranges.
7. Although Renesas Electronics endeavors to improve the quality and reliability of Renesas Electronics products, semiconductor products have specific characteristics, such as the occurrence of failure at a certain rate and malfunctions under certain use conditions. Unless designated as a high reliability product or a product for harsh environments in a Renesas Electronics data sheet or other Renesas Electronics document, Renesas Electronics products are not subject to radiation resistance design. You are responsible for implementing safety measures to guard against the possibility of bodily injury, injury or damage caused by fire, and/or danger to the public in the event of a failure or malfunction of Renesas Electronics products, such as safety design for hardware and software, including but not limited to redundancy, fire control and malfunction prevention, appropriate treatment for aging degradation or any other appropriate measures. Because the evaluation of microcomputer software alone is very difficult and impractical, you are responsible for evaluating the safety of the final products or systems manufactured by you.
8. Please contact a Renesas Electronics sales office for details as to environmental matters such as the environmental compatibility of each Renesas Electronics product. You are responsible for carefully and sufficiently investigating applicable laws and regulations that regulate the inclusion or use of controlled substances, including without limitation, the EU RoHS Directive, and using Renesas Electronics products in compliance with all these applicable laws and regulations. Renesas Electronics disclaims any and all liability for damages or losses occurring as a result of your noncompliance with applicable laws and regulations.
9. Renesas Electronics products and technologies shall not be used for or incorporated into any products or systems whose manufacture, use, or sale is prohibited under any applicable domestic or foreign laws or regulations. You shall comply with any applicable export control laws and regulations promulgated and administered by the governments of any countries asserting jurisdiction over the parties or transactions.
10. It is the responsibility of the buyer or distributor of Renesas Electronics products, or any other party who distributes, disposes of, or otherwise sells or transfers the product to a third party, to notify such third party in advance of the contents and conditions set forth in this document.
11. This document shall not be reprinted, reproduced or duplicated in any form, in whole or in part, without prior written consent of Renesas Electronics.
12. Please contact a Renesas Electronics sales office if you have any questions regarding the information contained in this document or Renesas Electronics products.

(Note 1) "Renesas Electronics" as used in this document means Renesas Electronics Corporation and also includes its directly or indirectly controlled subsidiaries.

(Note 2) "Renesas Electronics product(s)" means any product developed or manufactured by or for Renesas Electronics.

(Rev.4.0-1 November 2017)



SALES OFFICES

Renesas Electronics Corporation

<http://www.renesas.com>

Refer to "<http://www.renesas.com>" for the latest and detailed information.

Renesas Electronics Corporation

TOYOSU FORESIA, 3-2-24 Toyosu, Koto-ku, Tokyo 135-0061, Japan

Renesas Electronics America Inc.

1001 Murphy Ranch Road, Milpitas, CA 95035, U.S.A.
Tel: +1-408-432-8888, Fax: +1-408-434-5351

Renesas Electronics Canada Limited

9251 Yonge Street, Suite 8309 Richmond Hill, Ontario Canada L4C 9T3
Tel: +1-905-237-2004

Renesas Electronics Europe Limited

Dukes Meadow, Millboard Road, Bourne End, Buckinghamshire, SL8 5FH, U.K
Tel: +44-1628-651-700

Renesas Electronics Europe GmbH

Arcadiastrasse 10, 40472 Düsseldorf, Germany
Tel: +49-211-6503-0, Fax: +49-211-6503-1327

Renesas Electronics (China) Co., Ltd.

Room 1709 Quantum Plaza, No.27 ZhichunLu, Haidian District, Beijing, 100191 P. R. China
Tel: +86-10-8235-1155, Fax: +86-10-8235-7679

Renesas Electronics (Shanghai) Co., Ltd.

Unit 301, Tower A, Central Towers, 555 Langao Road, Putuo District, Shanghai, 200333 P. R. China
Tel: +86-21-2226-0888, Fax: +86-21-2226-0999

Renesas Electronics Hong Kong Limited

Unit 1601-1611, 16/F., Tower 2, Grand Century Place, 193 Prince Edward Road West, Mongkok, Kowloon, Hong Kong
Tel: +852-2265-6688, Fax: +852 2886-9022

Renesas Electronics Taiwan Co., Ltd.

13F, No. 363, Fu Shing North Road, Taipei 10543, Taiwan
Tel: +886-2-8175-9600, Fax: +886 2-8175-9670

Renesas Electronics Singapore Pte. Ltd.

80 Bendemeer Road, Unit #06-02 Hyflux Innovation Centre, Singapore 339949
Tel: +65-6213-0200, Fax: +65-6213-0300

Renesas Electronics Malaysia Sdn.Bhd.

Unit 1207, Block B, Menara Amcorp, Amcorp Trade Centre, No. 18, Jin Persiaran Barat, 46050 Petaling Jaya, Selangor Darul Ehsan, Malaysia
Tel: +60-3-7955-9390, Fax: +60-3-7955-9510

Renesas Electronics India Pvt. Ltd.

No.777C, 100 Feet Road, HAL 2nd Stage, Indiranagar, Bangalore 560 038, India
Tel: +91-80-67208700, Fax: +91-80-67208777

Renesas Electronics Korea Co., Ltd.

17F, KAMCO Yangjae Tower, 262, Gangnam-daero, Gangnam-gu, Seoul, 06265 Korea
Tel: +82-2-558-3737, Fax: +82-2-558-5338

Looking for pricing, stock, or lifecycle information?

Click below to explore more details on WIN SOURCE:

 [View ISL54233IRTZ-T on WIN SOURCE](#)

 [Intersil Information](#)

Optimize Your Supply Chain with WIN SOURCE Solutions

-  Global Sourcing Solution
-  Obsolete Management
-  Cost Control Management
-  Shortage Management
-  Alternative Solution
-  Excess Inventory Management