



**THE DATASHEET OF
ISL54220IUZ-T**



ISL54220

High-Speed USB 2.0 (480Mbps) Multiplexer

FN6819
Rev 1.00
February 4, 2010

The Intersil ISL54220 is a single supply dual 2:1 multiplexer that can operate from a single 2.7V to 5.5V supply. It contains two SPDT (Single Pole/Double Throw) switches configured as a DPDT. The part was designed for switching or routing of USB High-Speed signals and/or USB Full-speed signals in portable battery powered products.

The 6Ω switches can swing rail-to-rail and were specifically designed to pass USB full speed data signals that range from 0V to 3.3V and USB high speed data signals that range from 0V to 400mV. They have high bandwidth and low capacitance to pass USB high-speed data signals with minimal distortion.

The digital logic inputs are 1.8V logic compatible when operated with a 2.7V to 3.6V supply. The ISL54220 has an output enable pin to open all the switches.

The ISL54220 is available in 10 Ld 1.8mmx1.4mm μTQFN, 10 Ld TDFN and 10 Ld MSOP packages. It operates over a temperature range of -40 to +85°C.

Related Literature

- Technical Brief [TB363](#) "Guidelines for Handling and Processing Moisture Sensitive Surface Mount Devices (SMDs)"
- Application Note [AN1449](#) "ISL54220IRUEVAL1Z Evaluation Board User's Manual"

Features

- High-Speed (480Mbps) and Full-Speed (12Mbps) Signaling Capability per USB 2.0
- 1.8V Logic Compatible (2.7V to +3.6V supply)
- Enable Pin to Open all Switches
- Power OFF Protection
- D-/D+ Pins Overvoltage Tolerant to 5.5V
- -3dB Frequency 742MHz
- Low ON Capacitance @ 240MHz 4.2pF
- Low ON-Resistance @ VDD = 5.5V 4.5Ω
- Low ON-Resistance @ VDD = 3.3V 6.0Ω
- Single Supply Operation (V_{DD}) 2.7V to 5.5V
- Available in μTQFN, TDFN, and MSOP Packages
- Pb-Free (RoHS Compliant)
- Compliant with USB 2.0 Short Circuit and Overvoltage Requirements Without Additional External Components

Applications* (see page 15)

- MP3 and other Personal Media Players
- Cellular/Mobile Phones
- PDA's
- Digital Cameras and Camcorders
- USB Switching

Application Block Diagram

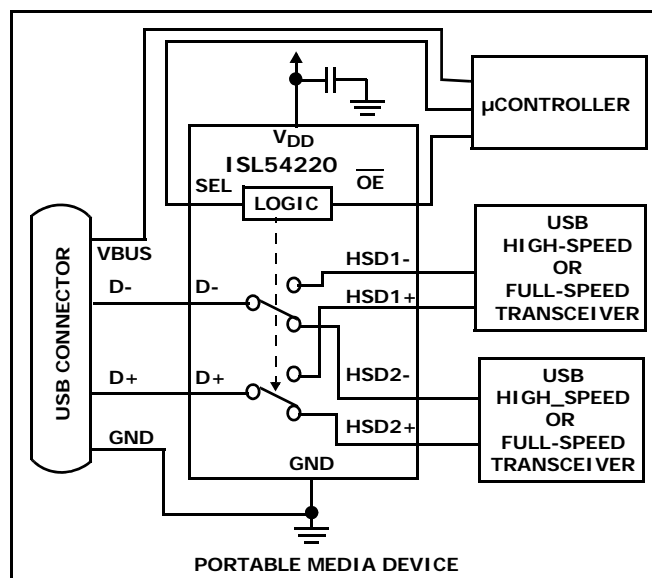

USB 2.0 HS Eye Pattern With Switches In The Signal Path

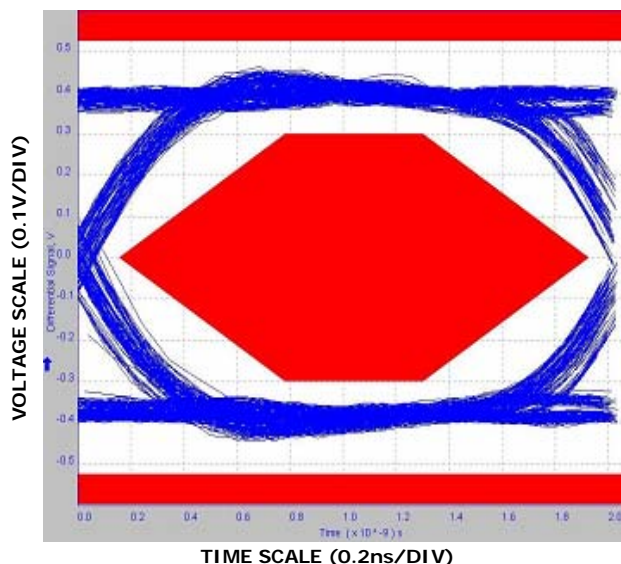

Pin Configurations

ISL54220
(10 LD 3.0X3.0 TDFN)
TOP VIEW

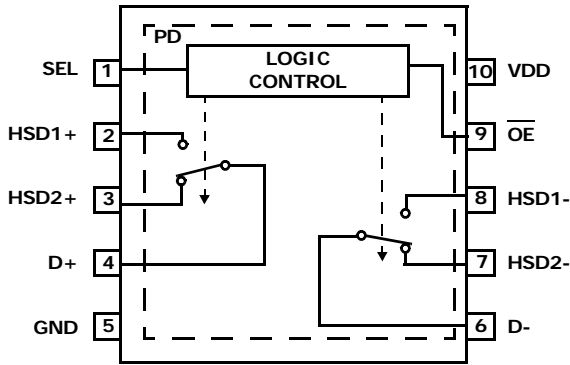

ISL54220
(10 LD MSOP)
TOP VIEW

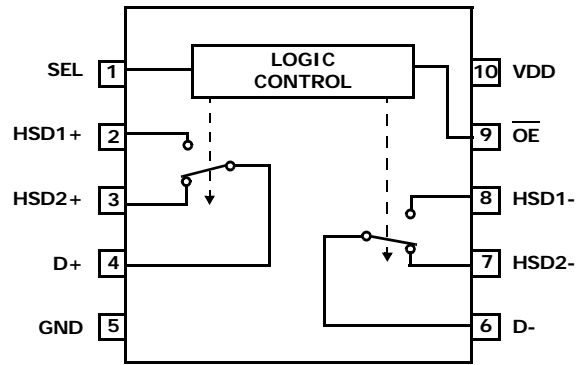

ISL54220
(10 LD 1.8X1.4 μTQFN)
TOP VIEW

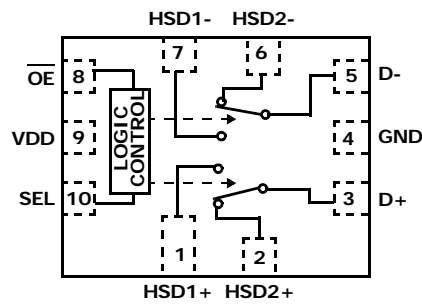

NOTE:

1. Switches Shown for SEL = Logic "1" and OE = Logic "0".

Truth Table

OE	SEL	HSD1-, HSD1+	HSD2-, HSD2+
0	0	ON	OFF
0	1	OFF	ON
1	X	OFF	OFF

Logic "0" when $\leq 0.5V$, Logic "1" when $\geq 1.4V$ with a 2.7V to 3.6V Supply.

Pin Descriptions

TDFN	MSOP	μTQFN	NAME	FUNCTION
10	10	9	VDD	Power Supply (2.7V to 5.5V)
1	1	10	SEL	Select Logic Control Input
2	2	1	HSD1+	USB Data Port (Channel 1 Positive Input)
3	3	2	HSD2+	USB Data Port (Channel 2 Positive Input)
4	4	3	D+	USB Data Common Positive Port
5	5	4	GND	Ground Connection
6	6	5	D-	USB Data Common Negative Port
7	7	6	HSD2-	USB Data Port (Channel 2 Negative Input)
8	8	7	HSD1-	USB Data Port (Channel 1 Negative Input)
9	9	8	OE	Bus Switch Enable
PD	-	-	PD	Thermal Pad. Tie to Ground or Float

Ordering Information

PART NUMBER (Note 5)	PART MARKING	TEMP. RANGE (°C)	PACKAGE (Pb-Free)	PKG. DWG. #
ISL54220IRUZ-T (Notes 2, 4)	H	-40 to +85	10 Ld 1.8mmx1.4mm μ TQFN (Tape and Reel)	L10.1.8x1.4A
ISL54220IRTZ (Note 3)	4220	-40 to +85	10 Ld 3x3 TDFN	L10.3x3A
ISL54220IRTZ-T (Notes 2, 3)	4220	-40 to +85	10 Ld 3x3 TDFN (Tape and Reel)	L10.3x3A
ISL54220IUZ (Note 3)	54220	-40 to +85	10 Ld MSOP	M10.118
ISL54220IUZ-T (Notes 2, 3)	54220	-40 to +85	10 Ld MSOP (Tape and Reel)	M10.118
ISL54220IRUEVAL1Z	Evaluation Board			

NOTES:

- Please refer to [TB347](#) for details on reel specifications.
- These Intersil Pb-free plastic packaged products employ special Pb-free material sets, molding compounds/die attach materials, and 100% matte tin plate plus anneal (e3 termination finish, which is RoHS compliant and compatible with both SnPb and Pb-free soldering operations). Intersil Pb-free products are MSL classified at Pb-free peak reflow temperatures that meet or exceed the Pb-free requirements of IPC/JEDEC J STD-020.
- These Intersil Pb-free plastic packaged products employ special Pb-free material sets; molding compounds/die attach materials and NiPdAu plate - e4 termination finish, which is RoHS compliant and compatible with both SnPb and Pb-free soldering operations. Intersil Pb-free products are MSL classified at Pb-free peak reflow temperatures that meet or exceed the Pb-free requirements of IPC/JEDEC J STD-020.
- For Moisture Sensitivity Level (MSL), please see device information page for [ISL54220](#). For more information on MSL please see techbrief [TB363](#).

Absolute Maximum Ratings

VDD to GND	-0.3 to 6.5V
Input Voltages	
HSD2x, HSD1x (Note 6)	- 0.3V to 6.5V
SEL, OE (Note 6)	-0.3 to ((VDD) + 0.3V)
Output Voltages	
D+, D- (Note 6)	-0.3V to 6.5V
Continuous Current (HSD2x, HSD1x)	±40mA
Peak Current (HSD2x, HSD1x)	
(Pulsed 1ms, 10% Duty Cycle, Max)	±100mA
ESD Rating	
Human Body Model	>6kV
Machine Model	>500V
Charged Device Model	>2kV
Latch-up Tested per JEDEC; Class II Level A	at +85°C

Thermal Information

Thermal Resistance (Typical)	θ_{JA} (°C/W)	θ_{JC} (°C/W)
10 Ld μ TQFN (Notes 8, 10)	160	105
10 Ld TDFN (Notes 8, 9)	55	18
10 Ld MSOP (Note 7, 10)	165	65
Maximum Junction Temperature (Plastic Package)	+150°C	
Maximum Storage Temperature Range	-65°C to +150°C	
Pb-Free Reflow Profile	see link below	
	http://www.intersil.com/pbfree/Pb-FreeReflow.asp	

Operating Conditions

Temperature Range	-40°C to +85°C
VDD Supply Voltage Range	2.7V to 5.5V
Logic Control Input Voltage	0V to VDD
Analog Signal Range	0V to VDD

CAUTION: Do not operate at or near the maximum ratings listed for extended periods of time. Exposure to such conditions may adversely impact product reliability and result in failures not covered by warranty.

NOTES:

- Signals on HSD1x, HSD2x, D+, D- exceeding GND by specified amount are clamped. Signals on OE and SEL exceeding VDD or GND by specified amount are clamped. Limit current to maximum current ratings.
- θ_{JA} is measured with the component mounted on a high effective thermal conductivity test board in free air. See Tech Brief TB379 for details.
- θ_{JA} is measured in free air with the component mounted on a high effective thermal conductivity test board with "direct attach" features. See Tech Brief TB379.
- For θ_{JC} , the "case temp" location is the center of the exposed metal pad on the package underside.
- For θ_{JC} , the "case temp" location is the center of the package top.

Electrical Specifications - 2.7V to 5.5V Supply

Test Conditions: VDD = +3.3V, GND = 0V, VSELH = 1.4V, VSELL = 0.5V, VOEH = 1.4V, VOEL = 0.5V, (Note 11), Unless Otherwise Specified.
Boldface limits apply over the operating temperature range, -40°C to +85°C.

PARAMETER	TEST CONDITIONS	TEMP (°C)	MIN (Notes 12, 13)	TYP	MAX (Notes 12, 13)	UNITS
ANALOG SWITCH CHARACTERISTICS						
Analog Signal Range, VANALOG	VDD = VDD, SEL = 0V or VDD, OE = 0V	Full	0	-	VDD	V
ON-Resistance, rON (High-Speed)	VDD = 2.7V, SEL = 0.5V or 1.4V, OE = 0.5V, IDX = 40mA, VHSD1x or VHSD2x = 0V to 400mV (see Figure 3, Note 16)	25	-	6.7	8	Ω
		Full	-	-	10	Ω
rON Matching Between Channels, Δr_{ON} (High-Speed)	VDD = 2.7V, SEL = 0.5V or 1.4V, OE = 0.5V, IDX = 40mA, VHSD1x or VHSD2x = Voltage at max rON, (Notes 15, 16)	25	-	0.117	0.45	Ω
		Full	-	-	0.55	Ω
rON Flatness, RFLAT(ON) (High-Speed)	VDD = 2.7V, SEL = 0.5V or 1.4V, OE = 0.5V, IDX = 40mA, VHSD1x or VHSD2x = 0V to 400mV, (Notes 14, 16)	25	-	0.94	1.2	Ω
		Full	-	-	1.3	Ω
OFF Leakage Current, IHSD1x(OFF)	VDD = 5.5V, SEL = VDD and OE = 0V or OE = VDD, VDx = 0.3V, 3.3V, VHSD1x = 3.3V, 0.3V, VHSD2x = 0.3V, 3.3V	25	-15	0.31	15	nA
		Full	-20	-	20	nA
ON Leakage Current, IHSD1x(ON)	VDD = 5.5V, SEL = OE = 0V, VDx = 0.3V, 3.3V, VHSD1x = 0.3V, 3.3V, VHSD2x = 3.3V, 0.3V	25	-20	2.2	20	nA
		Full	-25	-	25	nA
OFF Leakage Current, IHSD2x(OFF)	VDD = 5.5V, SEL = OE = 0V or OE = VDD, VDx = 3.3V, 0.3V, VHSD2x = 0.3V, 3.3V, VHSD1x = 3.3V, 0.3V	25	-15	0.26	15	nA
		Full	-20	-	20	nA

Electrical Specifications - 2.7V to 5.5V Supply

Test Conditions: $V_{DD} = +3.3V$, $GND = 0V$, $V_{SELH} = 1.4V$, $V_{SELL} = 0.5V$,
 $V_{OE H} = 1.4V$, $V_{OE L} = 0.5V$, (Note 11), Unless Otherwise Specified.
Boldface limits apply over the operating temperature range,
-40°C to +85°C. (Continued)

PARAMETER	TEST CONDITIONS	TEMP (°C)	MIN (Notes 12, 13)	TYP	MAX (Notes 12, 13)	UNITS
ON Leakage Current, $I_{HSD2x(ON)}$	$V_{DD} = 5.5V$, $SEL = V_{DD}$, $\overline{OE} = 0V$, $V_{Dx} = 0.3V, 3.3V$, $V_{HSD2x} = 0.3V, 3.3V$, $V_{HSD1x} = 3.3V, 0.3V$	25	-20	2.1	20	nA
		Full	-25	-	25	nA
Power OFF Leakage Current, I_{D+} , I_{D-}	$V_{DD} = 0V$, $V_{D+} = 0V$ to $5.25V$, $V_{D-} = 0V$ to $5.25V$, $SEL = \overline{OE} = V_{DD}$	25	-	0.0047	0.025	μA
		Full	-	-	0.40	μA
DYNAMIC CHARACTERISTICS						
Turn-ON Time, t_{ON}	$V_{DD} = 3.3V$, $R_L = 50\Omega$, $C_L = 10pF$ (see Figure 1)	25	-	35	-	ns
Turn-OFF Time, t_{OFF}	$V_{DD} = 3.3V$, $R_L = 50\Omega$, $C_L = 10pF$ (see Figure 1)	25	-	27	-	ns
Break-Before-Make Time Delay, t_D	$V_{DD} = 3.3V$, $R_L = 50\Omega$, $C_L = 10pF$ (see Figure 2)	25	-	10	-	ns
Skew, ($t_{SKEWOUT} - t_{SKEWIN}$)	$V_{DD} = 3.3V$, $SEL = 0V$ or $3.3V$, $\overline{OE} = 0V$, $R_L = 45\Omega$, $C_L = 10pF$, $t_R = t_F = 500ps$ at 480Mbps, (Duty Cycle = 50%) (see Figure 6)	25	-	50	-	ps
Rise/Fall Degradation (Propagation Delay), t_{PD}	$V_{DD} = 3.3V$, $SEL = 0V$ or $3.3V$, $\overline{OE} = 0V$, $R_L = 45\Omega$, $C_L = 10pF$, (see Figure 6)	25	-	250	-	ps
Crosstalk	$V_{DD} = 3.3V$, $R_L = 50\Omega$, $f = 240MHz$ (see Figure 5)	25	-	-36	-	dB
OFF-Isolation	$V_{DD} = 3.3V$, $\overline{OE} = 3.3V$, $R_L = 50\Omega$, $f = 240MHz$	25	-	-32	-	dB
-3dB Bandwidth	Signal = 0dBm, 0.2VDC offset, $R_L = 50\Omega$	25	-	742	-	MHz
OFF Capacitance, C_{HSxOFF}	$f = 1MHz$, $V_{DD} = 3.3V$, $SEL = 0V$, $\overline{OE} = 3.3V$, V_{HSD1x} or $V_{HSD2x} = V_{Dx} = 0V$ (see Figure 4)	25	-	2.8	-	pF
COM ON Capacitance, $C_{DX(ON)}$	$f = 1MHz$, $V_{DD} = 3.3V$, $SEL = 0V$ or $3.3V$, $\overline{OE} = 0V$, V_{HSD1x} or $V_{HSD2x} = V_{Dx} = 0V$ (see Figure 4)	25	-	7.4	-	pF
COM ON Capacitance, $C_{DX(ON)}$	$f = 240MHz$, $V_{DD} = 3.3V$, $SEL = 0V$ or $3.3V$, $\overline{OE} = 0V$, V_{HSD1x} or $V_{HSD2x} = V_{Dx}$ $= 0V$ (see Figure 4)	25	-	4.2	-	pF
POWER SUPPLY CHARACTERISTICS						
Power Supply Range, V_{DD}		Full	2.7		5.5	V
Positive Supply Current, I_{DD}	$V_{DD} = 5.5V$, $SEL = 0V$ or V_{DD} , $\overline{OE} = 0V$ or V_{DD}	25	-	0.009	0.03	μA
		Full	-	-	1	μA
Positive Supply Current, I_{DD}	$V_{DD} = 4.3V$, $SEL = 2.6V$, $\overline{OE} = 0V$ or $2.6V$	25	-	0.159	0.6	μA
		Full	-	-	1.6	μA
Positive Supply Current, I_{DD}	$V_{DD} = 3.6V$, $SEL = 1.4V$, $\overline{OE} = 0V$ or $1.4V$	25	-	6.6	10	μA
		Full	-	-	12	μA
DIGITAL INPUT CHARACTERISTICS						
Input Voltage Low, V_{SELL} , V_{OEL}	$V_{DD} = 2.7V$ to $3.6V$	Full	-	-	0.5	V
Input Voltage High, V_{SELH} , $V_{OE H}$	$V_{DD} = 2.7V$ to $3.6V$	Full	1.4	-	-	V
Input Voltage Low, V_{SELL} , V_{OEL}	$V_{DD} = 4.3V$ to $5.5V$	Full	-	-	0.8	V

Electrical Specifications - 2.7V to 5.5V Supply

Test Conditions: $V_{DD} = +3.3V$, $GND = 0V$, $V_{SELH} = 1.4V$, $V_{SELL} = 0.5V$, $V_{OE\overline{H}} = 1.4V$, $V_{OE\overline{L}} = 0.5V$, (Note 11), Unless Otherwise Specified.
Boldface limits apply over the operating temperature range, -40°C to +85°C. (Continued)

PARAMETER	TEST CONDITIONS	TEMP (°C)	MIN (Notes 12, 13)	TYP	MAX (Notes 12, 13)	UNITS
Input Voltage High, V_{SELH} , $V_{OE\overline{H}}$	$V_{DD} = 4.3V$ to $5.5V$	Full	2.0	-	-	V
Input Current, I_{SELL} , $I_{OE\overline{L}}$	$V_{DD} = 5.5V$, $SEL = 0V$, $\overline{OE} = 0V$	Full	-	3.3	-	nA
Input Current, I_{SELH}	$V_{DD} = 5.5V$, $SEL = 5.5V$	Full	-	-3.6	-	nA
Input Current, $I_{OE\overline{H}}$	$V_{DD} = 5.5V$, $\overline{OE} = 5.5V$	Full	-	-8.2	-	nA

NOTES:

- V_{LOGIC} = Input voltage to perform proper function.
- The algebraic convention, whereby the most negative value is a minimum and the most positive a maximum, is used in this data sheet.
- Parameters with MIN and/or MAX limits are 100% tested at +25°C, unless otherwise specified. Temperature limits established by characterization and are not production tested.
- Flatness is defined as the difference between maximum and minimum value of ON-resistance over the specified analog signal range.
- r_{ON} matching between channels is calculated by subtracting the channel with the highest max r_{ON} value from the channel with lowest max r_{ON} value, between HSD2+ and HSD2- or between HSD1+ and HSD1-.
- Limits established by characterization and are not production tested.

Test Circuits and Waveforms

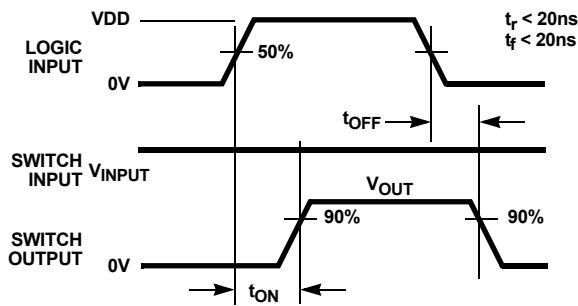

Logic input waveform is inverted for switches that have the opposite logic sense.

FIGURE 1A. MEASUREMENT POINTS

FIGURE 1. SWITCHING TIMES

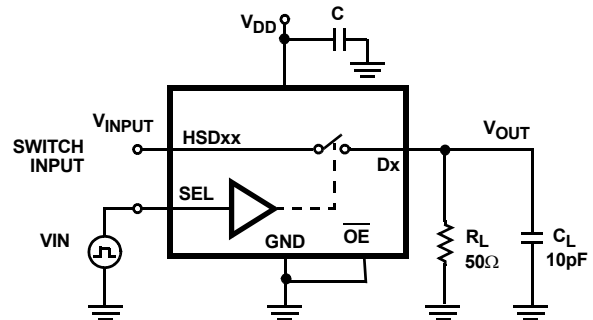

Repeat test for all switches. C_L includes fixture and stray capacitance.

$$V_{OUT} = V_{(INPUT)} \frac{R_L}{R_L + r_{ON}}$$

FIGURE 1B. TEST CIRCUIT

Test Circuits and Waveforms (Continued)

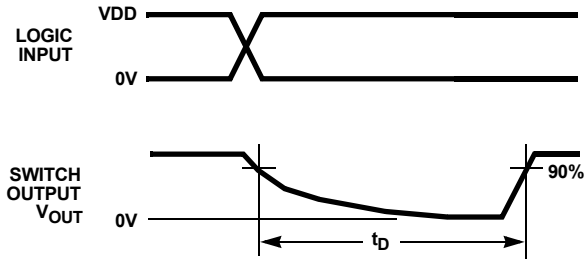
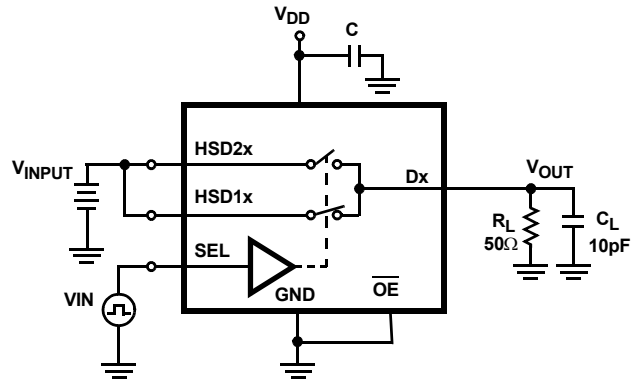

FIGURE 2A. MEASUREMENT POINTS



Repeat test for all switches. C_L includes fixture and stray capacitance.

FIGURE 2B. TEST CIRCUIT

FIGURE 2. BREAK-BEFORE-MAKE TIME

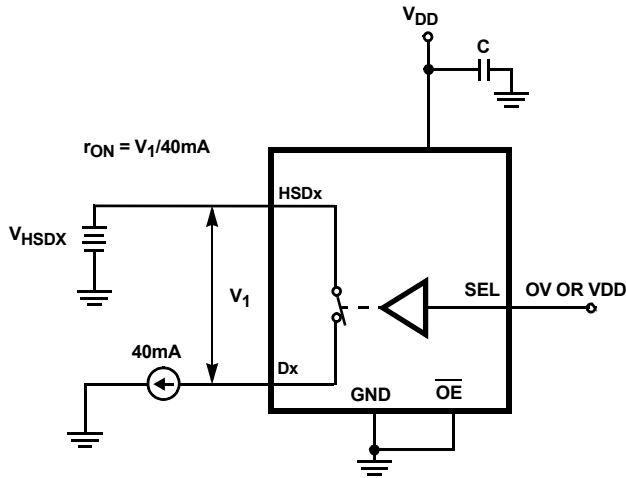

Repeat test for all switches.

FIGURE 3. r_{ON} TEST CIRCUIT

Test Circuits and Waveforms (Continued)

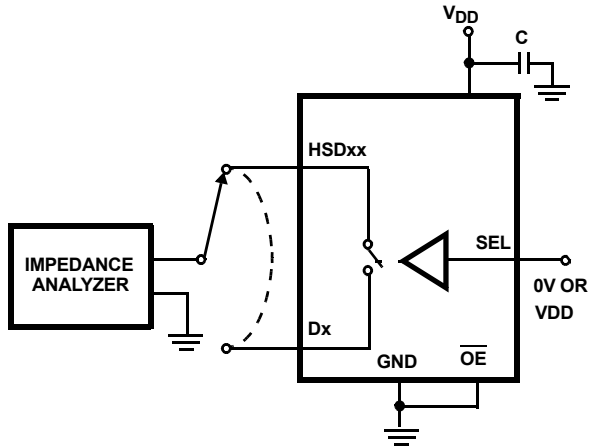

Repeat test for all switches.

FIGURE 4. CAPACITANCE TEST CIRCUIT

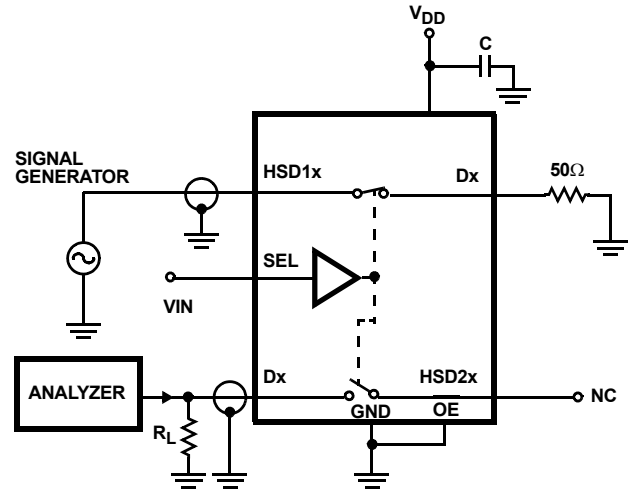

Signal direction through switch is reversed, worst case values are recorded. Repeat test for all switches.

FIGURE 5. CROSSTALK TEST CIRCUIT

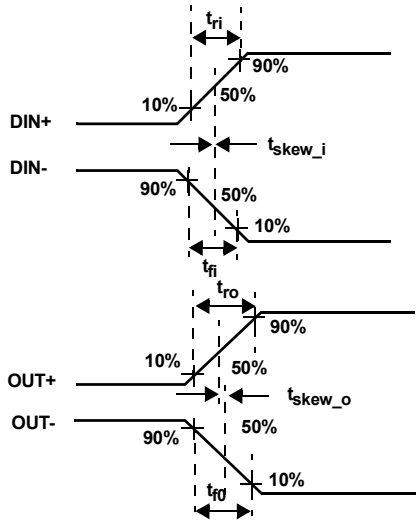
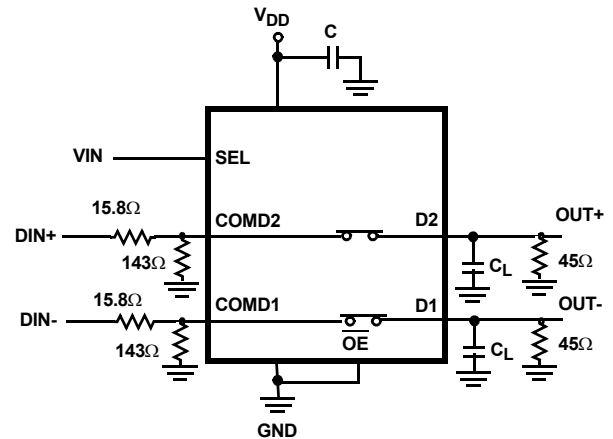

FIGURE 6A. MEASUREMENT POINTS



$|t_{ro} - t_{ri}|$ Delay Due to Switch for Rising Input and Rising Output Signals.
 $|t_{fo} - t_{fi}|$ Delay Due to Switch for Falling Input and Falling Output Signals.
 $|t_{skew_o}|$ Change in Skew through the Switch for Output Signals.
 $|t_{skew_i}|$ Change in Skew through the Switch for Input Signals.

FIGURE 6B. TEST CIRCUIT

FIGURE 6. SKEW TEST

Application Block Diagram

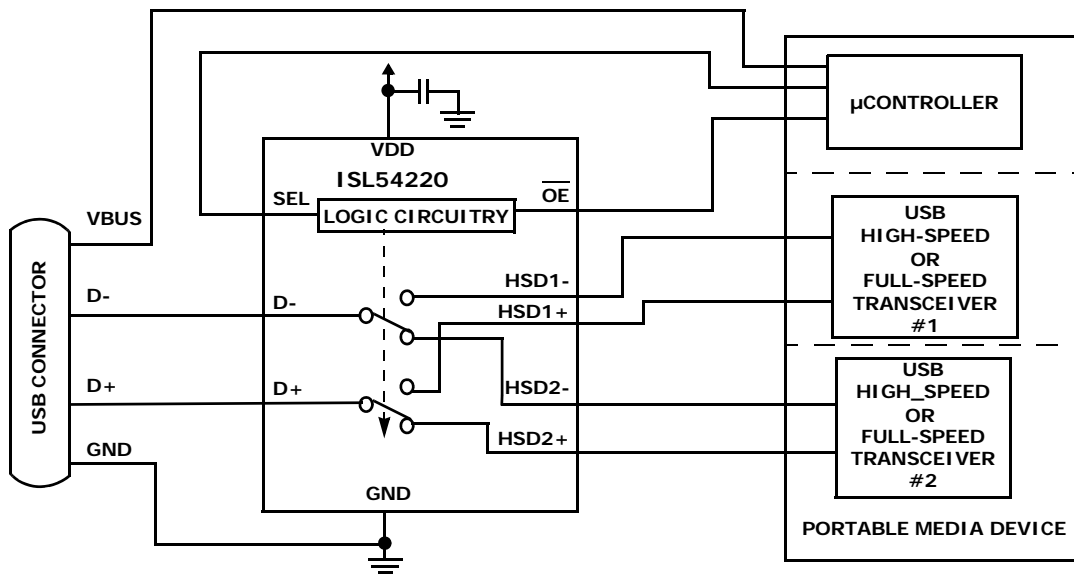

Detailed Description

The ISL54220 device is a dual single pole/double throw (SPDT) analog switch configured as a DPDT that operates from a single DC power supply in the range of 2.7V to 5.5V.

It was designed to function as a dual 2-to-1 multiplexer to select between two USB high-speed differential data signals in portable battery powered products. It is offered in a TDFN, MSOP, and a small μ TQFN packages for use in MP3 players, cameras, PDAs, cell phones, and other personal media players. The device has an enable pin to open all switches.

The part consists of four 6Ω high speed (HSx) switches. These switches have high bandwidth and low capacitance to pass USB high-speed (480Mbps) differential data signals with minimal edge and phase distortion. They can also swing from 0V to V_{DD} to pass USB full speed (12Mbps) differential data signals with minimal distortion.

The ISL54220 was designed for MP3 players, cameras, cell phones, and other personal media player applications that have multiple high-speed or full-speed transceivers sections and need to multiplex between these USB sources to a single USB host (computer). A typical application block diagram of this is shown on page 9.

A detailed description of the HS switches is provided in the following section.

High-Speed (HSx) Switches

The HSx switches (HSD1-, HSD1+, HSD2-, HSD2+) are bi-directional switches that can pass rail-to-rail signals. When powered with a 3.3V supply, these switches have a nominal r_{ON} of 6Ω over the signal range of 0V to 400mV with a r_{ON} flatness of 0.94Ω . The r_{ON} matching between

the HSD1 and HSD2 switches over this signal range is only 0.12Ω , ensuring minimal impact by the switches to USB high speed signal transitions. As the signal level increases, the r_{ON} switch resistance increases. At signal level of 3.3V, the switch resistance is nominally 129Ω . See Figures 7, 8, 9, 10 in the "Typical Performance Curves" beginning on page 11.

The HSx switches were specifically designed to pass USB 2.0 high-speed (480Mbps) differential signals in the range of 0V to 400mV. They have low capacitance and high bandwidth to pass the USB high-speed signals with minimum edge and phase distortion to meet USB 2.0 high speed signal quality specifications. See Figure 11 in the "Typical Performance Curves" on page 12 for USB High-speed Eye Pattern taken with switch in the signal path.

The HSx switches can also pass USB full-speed signals (12Mbps) with minimal distortion and meet all the USB requirements for USB 2.0 full-speed signaling. See Figure 12 in the "Typical Performance Curves" on page 13 for USB Full-speed Eye Pattern taken with switch in the signal path.

The maximum normal operating signal range for the HSx switches is from 0V to V_{DD} . The signal voltage should not be allowed to exceed the V_{DD} voltage rail or go below ground by more than $-0.3V$ for normal operation.

However, in the event that the USB 5.25V V_{BUS} voltage gets shorted to one or both of the D-/D+ pins, the ISL54220 has special fault protection circuitry to prevent damage to the ISL54220 part. The fault circuitry allows the signal pins (D-, D+, HS1D-, HS1D+, HS2D-, HS2D+) to be driven up to 5.5V while the V_{DD} supply voltage is in the range of 0V to 5.5V. In this condition the part draws $< 500\mu A$ of current and causes no stress to the IC. In addition when V_{DD} is at 0V (ground) all switches are OFF

and the fault voltage is isolated from the other side of the switch. When V_{DD} is in the range of 2.7V to 5.5V the fault voltage will pass through to the output of an active switch channel.

The HS1 channel switches are active (turned ON) whenever the SEL voltage is logic "0" (Low) and the \overline{OE} voltage is logic "0" (Low).

The HS2 channel switches are active (turned ON) whenever the SEL voltage is logic "1" (High) and the \overline{OE} voltage is logic "0" (Low).

ISL54220 Operation

The following will discuss using the ISL54220 shown in the "Application Block Diagram" on page 9.

POWER

The power supply connected at the VDD pin provides the DC bias voltage required by the ISL54220 part for proper operation. The ISL54220 can be operated with a VDD voltage in the range of 2.7V to 5.5V. When used in a USB application, the VDD voltage should be kept in the range of 3.0V to 5.5V to ensure you get the proper signal levels for good signal quality.

A 0.01 μ F or 0.1 μ F decoupling capacitor should be connected from the VDD pin to ground to filter out any power supply noise from entering the part. The capacitor should be located as close to the VDD pin as possible.

In a typical application, V_{DD} will be in the range of 2.8V to 4.3V and will be connected to the battery or LDO of the portable media device.

LOGIC CONTROL

The state of the ISL54220 device is determined by the voltage at the SEL pin and the \overline{OE} pin. SEL is only active when the \overline{OE} pin is logic "0" (Low). Refer to "Truth Table" on page 2.

The ISL54220 logic pins are designed to minimize current consumption when the logic control voltage is lower than the V_{DD} supply voltage. With $V_{DD} = 3.6V$ and logic pins at 1.4V the part typically draws only 6.6 μ A. With $V_{DD} = 4.3V$ and logic pins at 2.6V, the part typically draws only 0.2 μ A. Driving the logic pins to the V_{DD} supply rail minimizes power consumption.

The logic pins must be held High or Low and must not float.

Logic Control Voltage Levels

With V_{DD} supply voltage in the range of 2.7V to 3.6V the logic levels are:

$\overline{OE} = \text{Logic "0" (Low) when } V_{\overline{OE}} \leq 0.5V$
 $\overline{OE} = \text{Logic "1" (High) when } V_{\overline{OE}} \geq 1.4V$
 $SEL = \text{Logic "0" (Low) when } V_{SEL} \leq 0.5V$
 $SEL = \text{Logic "1" (High) when } V_{SEL} \geq 1.4V$

With V_{DD} supply voltage in the range of 4.3V to 5.5V the logic levels are:

$\overline{OE} = \text{Logic "0" (Low) when } V_{\overline{OE}} \leq 0.8V$
 $\overline{OE} = \text{Logic "1" (High) when } V_{\overline{OE}} \geq 2.0V$
 $SEL = \text{Logic "0" (Low) when } V_{SEL} \leq 0.8V$
 $SEL = \text{Logic "1" (High) when } V_{SEL} \geq 2.0V$

HSD1 USB Channel

If the SEL pin = Logic "0" and the \overline{OE} pin = Logic "0", high-speed Channel 1 will be ON. The HSD1- and HSD1+ switches are ON and the HSD2- and HSD2+ switches are OFF (high impedance).

When a computer or USB hub is plugged into the common USB connector and channel one is active, a link will be established between the USB 1 driver section of the media player and the computer. The device will be able to transmit and receive data from the computer at a data rate of 480Mbps.

HSD2 USB Channel

If the SEL pin = Logic "1" and the \overline{OE} pin = Logic "0", high-speed Channel 2 will be ON. The HSD2- and HSD2+ switches are ON and the HSD1- and HSD1+ switches are OFF (high impedance).

When a USB cable from a computer or USB hub is connected at the common USB connector and the part has Channel 2 active, a link will be established between the USB 2 driver section of the media player and the computer. The device will be able to transmit and receive data from the computer at a data rate of 480Mbps.

All Switches OFF Mode

If the SEL pin = Logic "0" or Logic "1" and the \overline{OE} pin = Logic "1", all of the switches will turn OFF (high impedance).

The all OFF state can be used to switch between the two USB sections of the media player. When disconnecting from one USB device to the other USB device, you can momentarily put the ISL54220 switch in the "all off" state in order to get the computer to disconnect from the one device so it can properly connect to the other USB device when that channel is turned ON.

USB 2.0 V_{BUS} Short Requirements

The USB specification in section 7.1.1 states a USB device must be able to withstand a V_{BUS} short to the D+ or D- signal lines when the device is either powered off or powered on for at least 24 hours. The ISL54220 part has special fault protection circuitry to meet these short circuit requirements.

The fault protection circuitry allows the signal pins (D-, D+, HS1D-, HS1D+, HS2D-, HS2D+) to be driven up to 5.5V while the V_{DD} supply voltage is in the range of 0V to 5.5V. In this overvoltage condition the part draws <500 μ A of current and causes no stress/damage to the IC.

In addition when V_{DD} is at 0V (ground), all switches are OFF and the shorted V_{BUS} voltage is isolated from the other side of the switch.

When V_{DD} is in the range of 2.7V to 5.5V, the shorted V_{BUS} voltage will pass through to the output of an active (turned ON) switch channel but not through a turned OFF channel. Any components connected on the active

channel must be able to withstand the overvoltage condition.

Note: During the fault condition normal operation of the USB channel is not guaranteed until the fault condition is removed.

Typical Performance Curves $T_A = +25^\circ\text{C}$, Unless Otherwise Specified

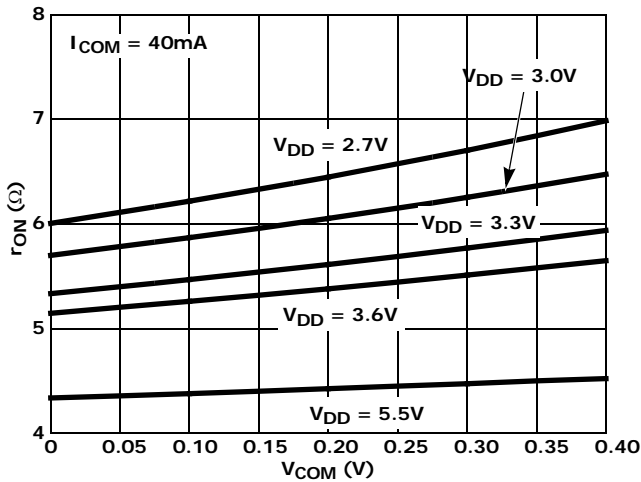

FIGURE 7. ON-RESISTANCE vs SUPPLY VOLTAGE vs SWITCH VOLTAGE

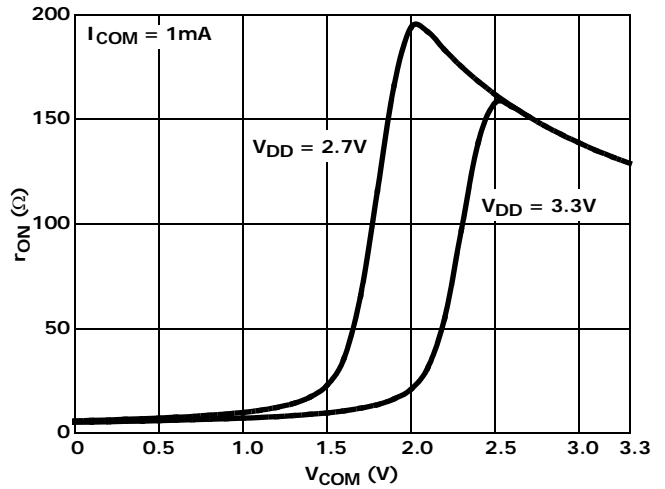

FIGURE 8. ON-RESISTANCE vs SUPPLY VOLTAGE vs SWITCH VOLTAGE

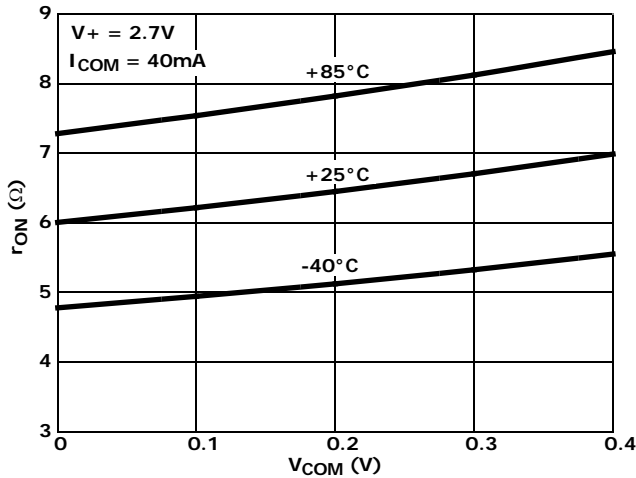

FIGURE 9. ON-RESISTANCE vs SWITCH VOLTAGE

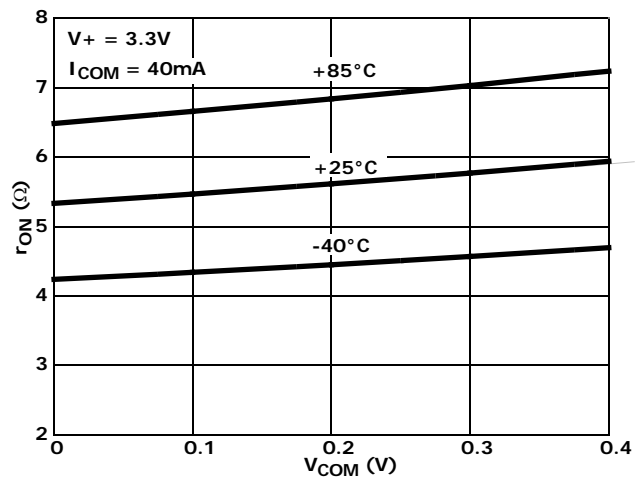

FIGURE 10. ON-RESISTANCE vs SWITCH VOLTAGE

Typical Performance Curves $T_A = +25^\circ\text{C}$, Unless Otherwise Specified (Continued)

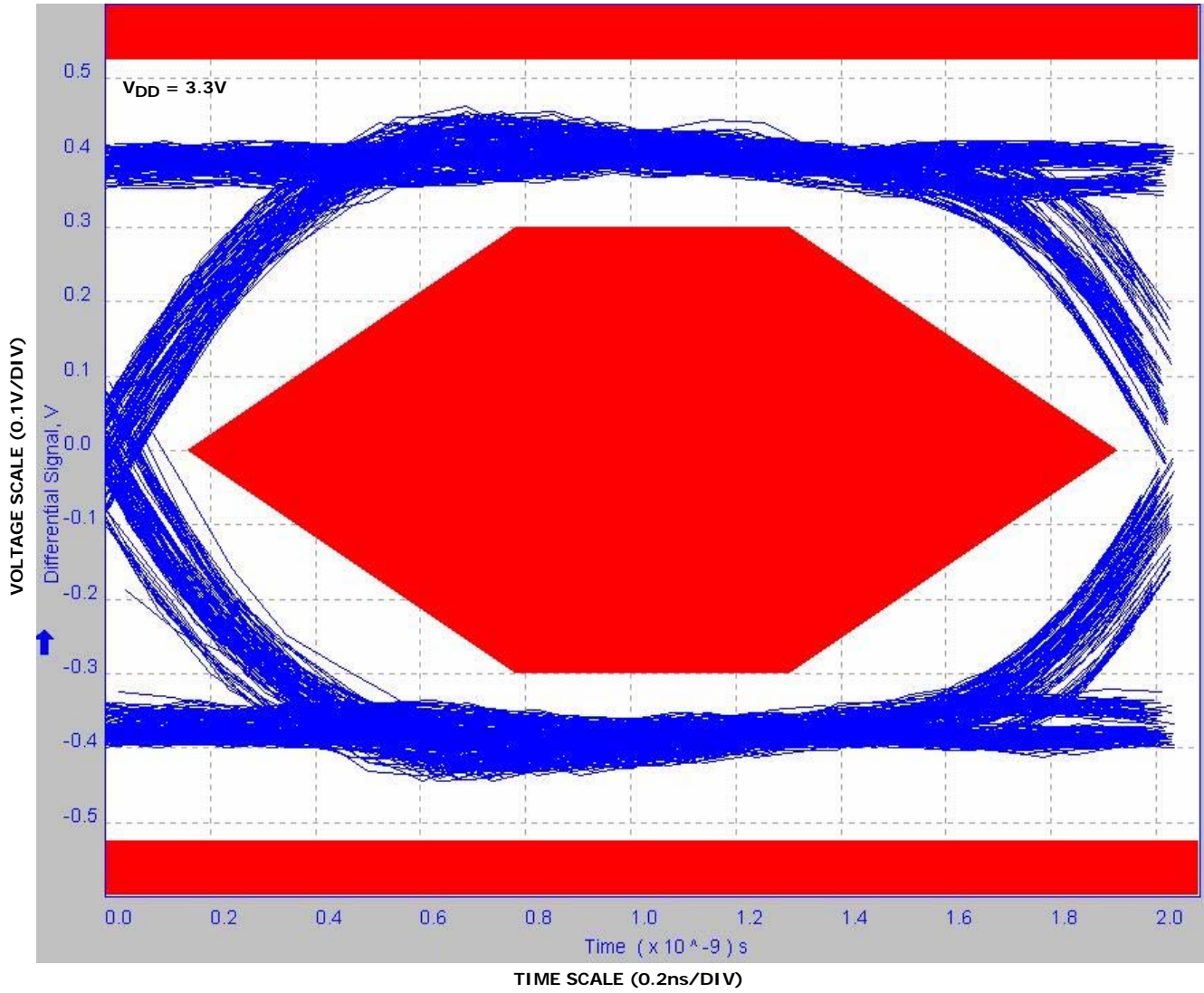

FIGURE 11. EYE PATTERN: 480Mbps WITH USB SWITCHES IN THE SIGNAL PATH

Typical Performance Curves $T_A = +25^\circ\text{C}$, Unless Otherwise Specified (Continued)

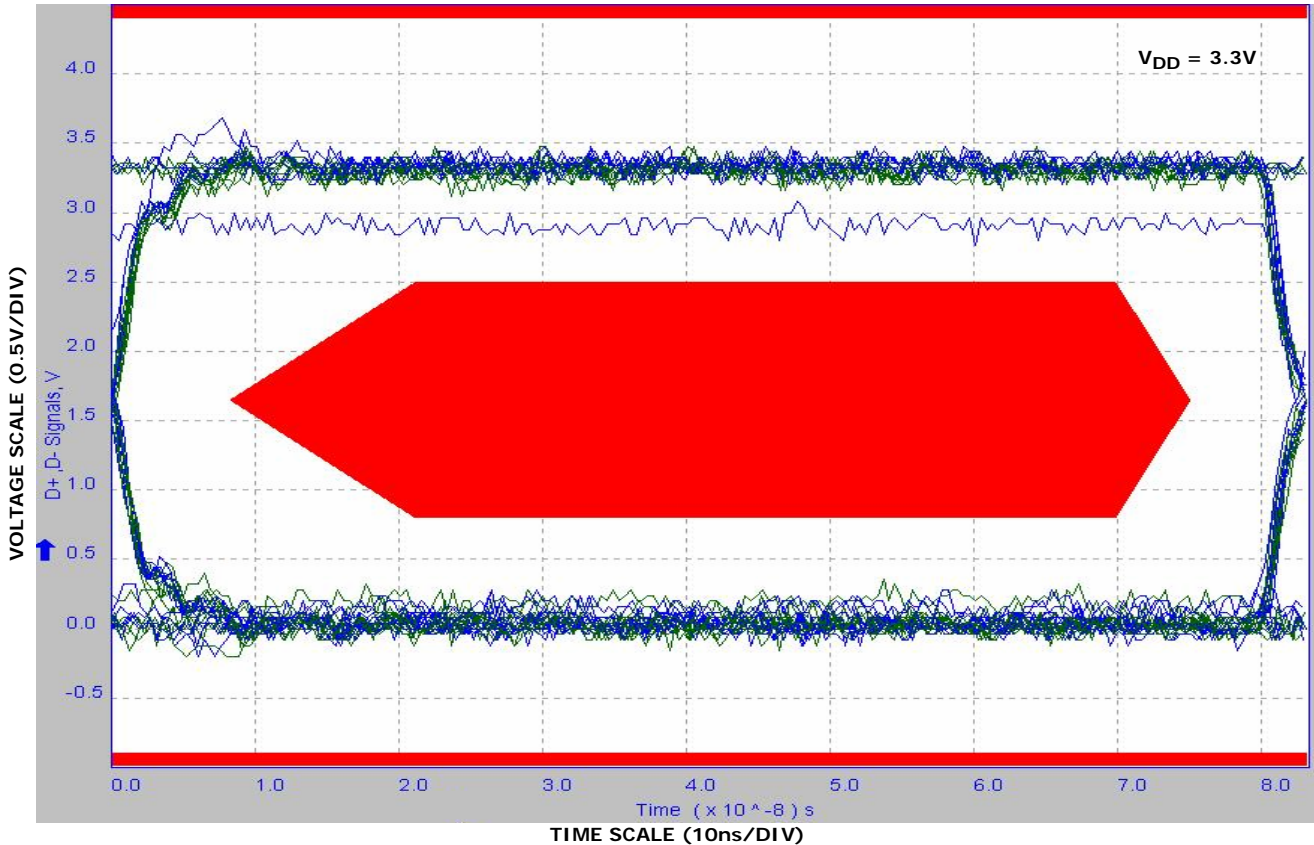

FIGURE 12. EYE PATTERN: 12Mbps WITH USB SWITCHES IN THE SIGNAL PATH

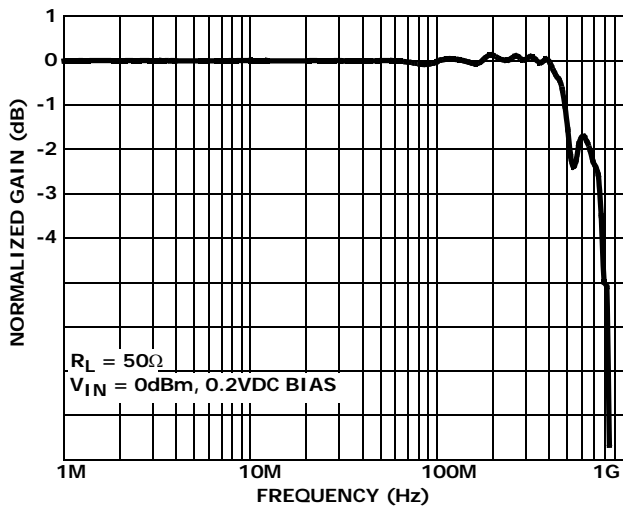

FIGURE 13. FREQUENCY RESPONSE

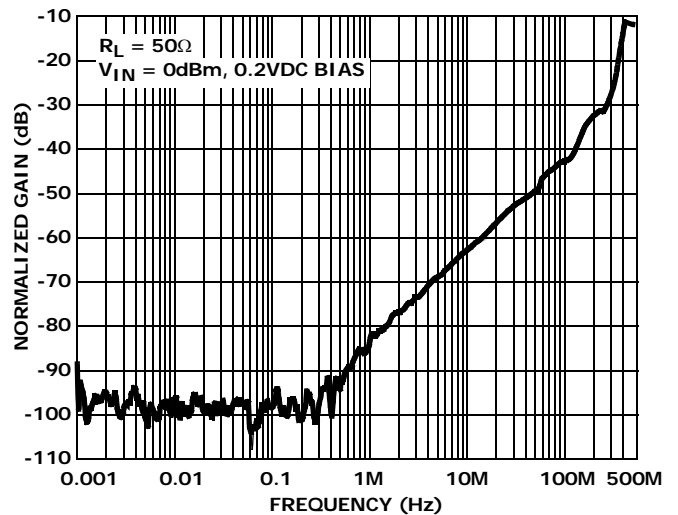

FIGURE 14. OFF-ISOLATION

Typical Performance Curves $T_A = +25^\circ\text{C}$, Unless Otherwise Specified (Continued)

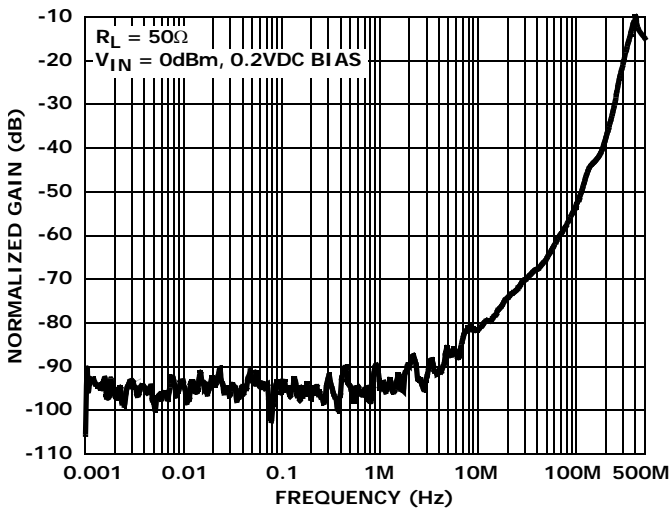

FIGURE 15. CROSSTALK

Die Characteristics

SUBSTRATE AND TDFN THERMAL PAD POTENTIAL (POWERED UP):

GND

TRANSISTOR COUNT:

325

PROCESS:

Submicron CMOS

Revision History

The revision history provided is for informational purposes only and is believed to be accurate, but not warranted. Please go to web to make sure you have the latest Rev.

DATE	REVISION	CHANGE
2/4/10	FN6819.1	<p>Updated to new Intersil data sheet format.</p> <p>Page 1 Updated with Related Literature and Marketing graphics.</p> <p>In Pin Configurations on page 2: 10 Ld MSOP and 10 Ld TDFN used to have same Pinout. Made separate pinout for the 10 Ld TDFN</p> <p>Updated Pin Description Table on page 2 to new format by adding pin number and package type columns.</p> <p>Added MSL note to Ordering information on page 3.</p> <p>Added Latchup to "Absolute Maximum Ratings" on page 4.</p> <p>"Thermal Information" on page 4: Added Theta JC value of 105 and applicable Theta JC note for the 10 Ld μTQFN. Added Theta JC value of 65 and applicable Theta JC note for 10 Ld MSOP.</p> <p>10 Ld μTQFN Theta JA note changed from:</p> <p>"θ_{JA} is measured with the component mounted on a high effective thermal conductivity test board in free air. See Tech Brief TB379 for details."</p> <p>to:</p> <p>θ_{JA} is measured in free air with the component mounted on a high effective thermal conductivity test board with "direct attach" features. See Tech Brief TB379."</p> <p>Updated package outline drawings L10.1.8x1.4A and L10.3x3A to most recent revisions.</p> <p>Changes to L10.1.8x1.4A were to add solder footprint. Changes to L10.3x3A were to change tolerance in top view from 0.15 to 0.10. Changes to L10.1.8x1.4A were to add solder footprint. Changes to L10.3x3A were to change tolerance in top view from 0.15 to 0.10.</p> <p>On"" on page 1 in Features section changed On Capacitance from 7.4pF to 4.2pF at 240MHz.</p> <p>Page 1 in Features section changed from:</p> <ul style="list-style-type: none"> • Low ON-Resistance 6.7Ω <p>to:</p> <ul style="list-style-type: none"> • Low ON-Resistance @ VDD = 5.5V 4.5Ω • Low ON-Resistance @ VDD = 3.3V 6.0Ω <p>Page 5 in Electrical Specification table added COM ON Capacitance, $C_{DX(ON)}$ at f = 240MHz</p>
12/16/08	FN6819.0	Initial Release.

Products

Intersil Corporation is a leader in the design and manufacture of high-performance analog semiconductors. The Company's products address some of the industry's fastest growing markets, such as, flat panel displays, cell phones, handheld products, and notebooks. Intersil's product families address power management and analog signal processing functions. Go to www.intersil.com/products for a complete list of Intersil product families.

*For a complete listing of Applications, Related Documentation and Related Parts, please see the respective device information page on intersil.com: [ISL54220](http://www.intersil.com/ISL54220)

To report errors or suggestions for this datasheet, please go to www.intersil.com/askourstaff

FITs are available from our website at <http://rel.intersil.com/reports/search.php>

© Copyright Intersil Americas LLC 2008-2010. All Rights Reserved.
All trademarks and registered trademarks are the property of their respective owners.

For additional products, see www.intersil.com/en/products.html

Intersil products are manufactured, assembled and tested utilizing ISO9001 quality systems as noted in the quality certifications found at www.intersil.com/en/support/qualandreliability.html

Intersil products are sold by description only. Intersil may modify the circuit design and/or specifications of products at any time without notice, provided that such modification does not, in Intersil's sole judgment, affect the form, fit or function of the product. Accordingly, the reader is cautioned to verify that datasheets are current before placing orders. Information furnished by Intersil is believed to be accurate and reliable. However, no responsibility is assumed by Intersil or its subsidiaries for its use; nor for any infringements of patents or other rights of third parties which may result from its use. No license is granted by implication or otherwise under any patent or patent rights of Intersil or its subsidiaries.

For information regarding Intersil Corporation and its products, see www.intersil.com

Thin Dual Flat No-Lead Plastic Package (TDFN)

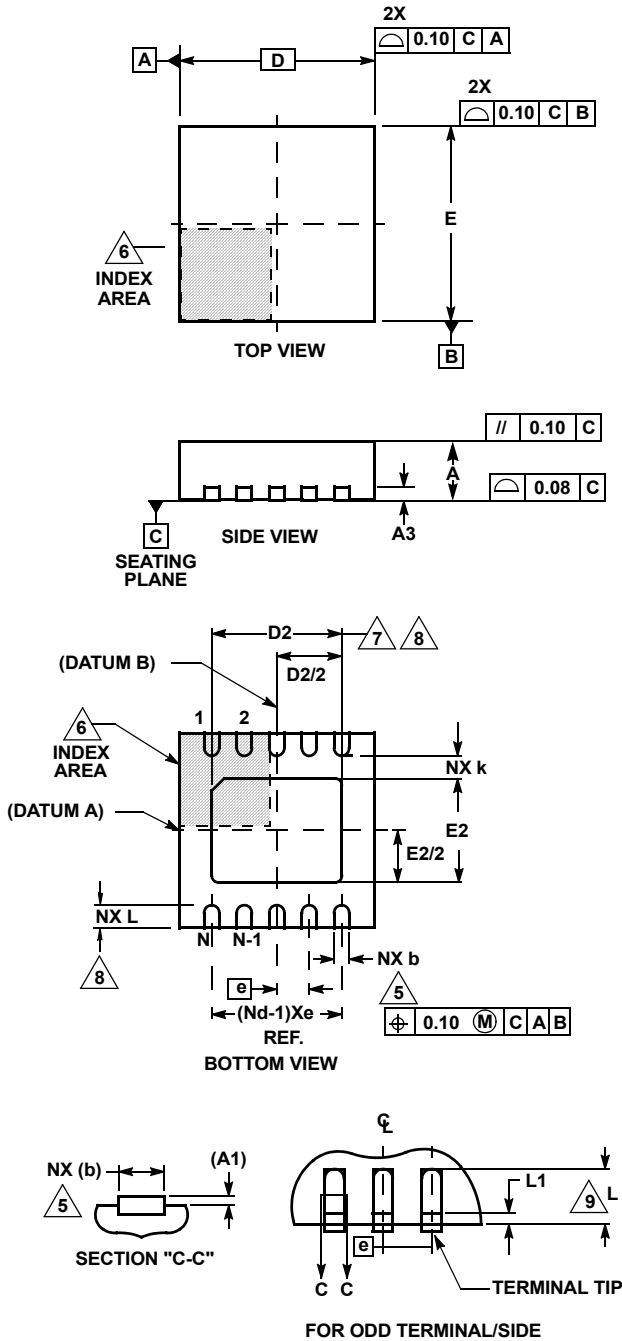

L10.3x3A

10 LEAD THIN DUAL FLAT NO-LEAD PLASTIC PACKAGE

SYMBOL	MILLIMETERS			NOTES
	MIN	NOMINAL	MAX	
A	0.70	0.75	0.80	-
A1	-	-	0.05	-
A3	0.20 REF			-
b	0.20	0.25	0.30	5, 8
D	2.95	3.0	3.05	-
D2	2.25	2.30	2.35	7, 8
E	2.95	3.0	3.05	-
E2	1.45	1.50	1.55	7, 8
e	0.50 BSC			-
k	0.25	-	-	-
L	0.25	0.30	0.35	8
N	10			2
Nd	5			3

Rev. 4 8/09

NOTES:

1. Dimensioning and tolerancing conform to ASME Y14.5-1994.
2. N is the number of terminals.
3. Nd refers to the number of terminals on D.
4. All dimensions are in millimeters. Angles are in degrees.
5. Dimension b applies to the metallized terminal and is measured between 0.15mm and 0.30mm from the terminal tip.
6. The configuration of the pin #1 identifier is optional, but must be located within the zone indicated. The pin #1 identifier may be either a mold or mark feature.
7. Dimensions D2 and E2 are for the exposed pads which provide improved electrical and thermal performance.
8. Nominal dimensions are provided to assist with PCB Land Pattern Design efforts, see Intersil Technical Brief TB389.
9. Compliant to JEDEC MO-229-WEED-3 except for D2 dimensions.

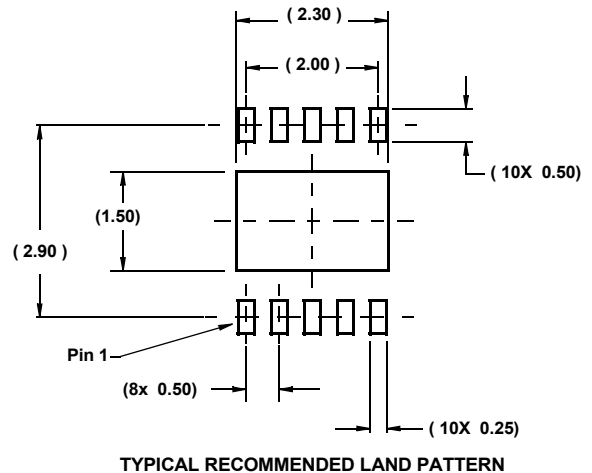

Mini Small Outline Plastic Packages (MSOP)

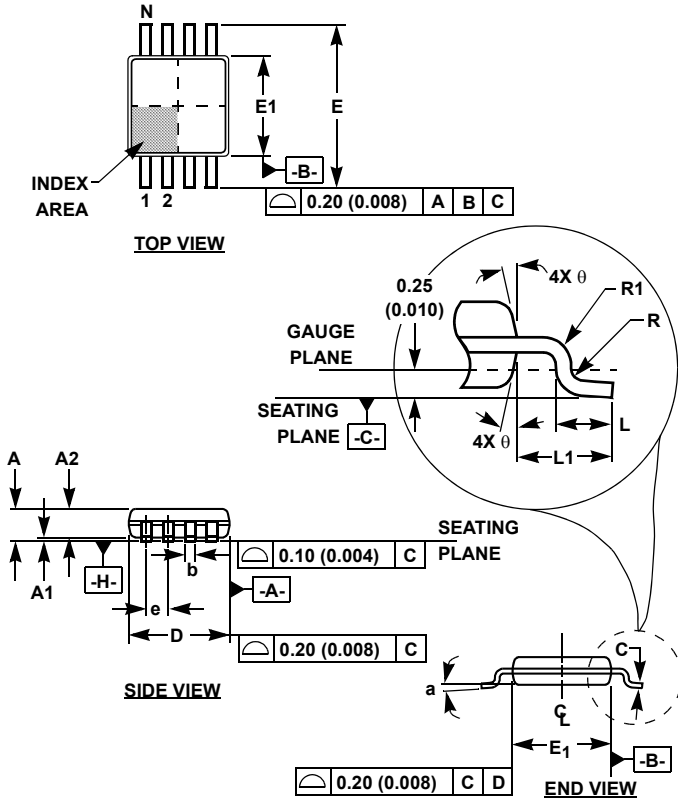

M10.118 (JEDEC MO-187BA)
10 LEAD MINI SMALL OUTLINE PLASTIC PACKAGE

SYMBOL	INCHES		MILLIMETERS		NOTES
	MIN	MAX	MIN	MAX	
A	0.037	0.043	0.94	1.10	-
A1	0.002	0.006	0.05	0.15	-
A2	0.030	0.037	0.75	0.95	-
b	0.007	0.011	0.18	0.27	9
c	0.004	0.008	0.09	0.20	-
D	0.116	0.120	2.95	3.05	3
E1	0.116	0.120	2.95	3.05	4
e	0.020 BSC		0.50 BSC		-
E	0.187	0.199	4.75	5.05	-
L	0.016	0.028	0.40	0.70	6
L1	0.037 REF		0.95 REF		-
N	10		10		7
R	0.003	-	0.07	-	-
R1	0.003	-	0.07	-	-
θ	5°	15°	5°	15°	-
α	0°	6°	0°	6°	-

Rev. 0 12/02

NOTES:

1. These package dimensions are within allowable dimensions of JEDEC MO-187BA.
2. Dimensioning and tolerancing per ANSI Y14.5M-1994.
3. Dimension "D" does not include mold flash, protrusions or gate burrs and are measured at Datum Plane. Mold flash, protrusion and gate burrs shall not exceed 0.15mm (0.006 inch) per side.
4. Dimension "E1" does not include interlead flash or protrusions and are measured at Datum Plane. [-H-] Interlead flash and protrusions shall not exceed 0.15mm (0.006 inch) per side.
5. Formed leads shall be planar with respect to one another within 0.10mm (.004) at seating Plane.
6. "L" is the length of terminal for soldering to a substrate.
7. "N" is the number of terminal positions.
8. Terminal numbers are shown for reference only.
9. Dimension "b" does not include dambar protrusion. Allowable dambar protrusion shall be 0.08mm (0.003 inch) total in excess of "b" dimension at maximum material condition. Minimum space between protrusion and adjacent lead is 0.07mm (0.0027 inch).
10. Datums [-A-] and [-B-] to be determined at Datum plane [-H-].
11. Controlling dimension: MILLIMETER. Converted inch dimensions are for reference only

Looking for pricing, stock, or lifecycle information?

Click below to explore more details on WIN SOURCE:

 [View ISL54220IUZ-T on WIN SOURCE](#)

 [Intersil Information](#)

Optimize Your Supply Chain with WIN SOURCE Solutions

-  Global Sourcing Solution
-  Obsolete Management
-  Cost Control Management
-  Shortage Management
-  Alternative Solution
-  Excess Inventory Management