



**THE DATASHEET OF  
ISL54056IRUZ-T**



**NOT RECOMMENDED FOR NEW DESIGNS  
RECOMMENDED REPLACEMENT PART  
ISL54050**

## ISL54056

Ultra Low ON-Resistance, +1.65V to +4.5V, Single Supply, Quad SPDT (Dual DPDT) Analog Switch

FN6357  
Rev 4.00  
Aug 15, 2007

The Intersil ISL54056 device is a low ON-resistance, low voltage, bidirectional, Quad SPDT (Dual DPDT) analog switch designed to operate from a single +1.65V to +4.5V supply. Targeted applications include battery powered equipment that benefit from low  $r_{ON}$  (0.39 $\Omega$ ) and fast switching speeds ( $t_{ON} = 30ns$ ,  $t_{OFF} = 16ns$ ). The digital logic input is 1.8V logic-compatible when using a single +3V supply. With a supply voltage of 4.2V and logic high voltage of 2.85V at both logic inputs, the part draws only 12 $\mu$ A max of ICC current.

Cell phones, for example, often face ASIC functionality limitations. The number of analog input or GPIO pins may be limited and digital geometries are not well suited to analog switch performance. This part may be used to “mux-in” additional functionality while reducing ASIC design risk. The ISL54056 is offered in small form factor package, alleviating board space limitations.

The ISL54056 consists of four SPDT switches. It is configured as a dual double-pole/double-throw (DPDT) device with two logic control inputs that control two SPDT switches each. The configuration can be used as a dual differential 2-to-1 multiplexer/demultiplexer. The ISL54056 is pin compatible with the NLAS3799 and NLAS3799L.

**TABLE 1. FEATURES AT A GLANCE**

	ISL54056
<b>Number of Switches</b>	4
<b>SW</b>	Quad SPDT (Dual DPDT)
<b>4.3V <math>r_{ON}</math></b>	0.39 $\Omega$
<b>4.3V <math>t_{ON}/t_{OFF}</math></b>	30ns/16ns
<b>3.0V <math>r_{ON}</math></b>	0.45 $\Omega$
<b>3.0V <math>t_{ON}/t_{OFF}</math></b>	34ns/18ns
<b>1.8V <math>r_{ON}</math></b>	0.65 $\Omega$
<b>1.8V <math>t_{ON}/t_{OFF}</math></b>	48ns/23ns
<b>Package</b>	16 Ld 2.6x1.8x0.5mm $\mu$ TQFN

### Features

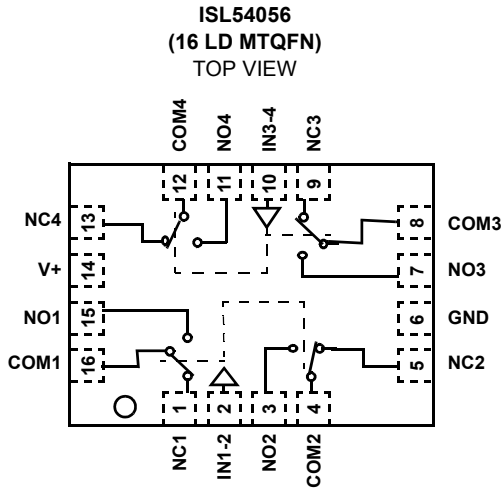
- Pin Compatible Replacement for the NLAS3799 and NLAS3799L
- ON-Resistance ( $r_{ON}$ )
  - V+ = +4.3V ..... 0.39 $\Omega$
  - V+ = +3.0V ..... 0.45 $\Omega$
  - V+ = +1.8V ..... 0.65 $\Omega$
- $r_{ON}$  Matching between Channels ..... 0.05 $\Omega$
- $r_{ON}$  Flatness Across Signal Range ..... 0.05 $\Omega$
- Single Supply Operation. .... +1.65V to +4.5V
- Low Power Consumption (PD). .... <0.68 $\mu$ W
- Fast Switching Action (V+ = +4.3V)
  - $t_{ON}$  ..... 30ns
  - $t_{OFF}$  ..... 16ns
- Break-Before-Make
- 1.8V Logic Compatible (+3V supply)
- Low ICC Current when VinH is not at the V+ Rail
- Available in 16 Ld 2.6mmx1.8mmx0.5mm  $\mu$ TQFN
- ESD HBM Rating
  - COM Pins ..... 9kV
  - All Other Pins ..... 6kV
- Pb-Free Available (RoHS Compliant)

### Applications

- Battery Powered, Handheld, and Portable Equipment
  - Cellular/Mobile Phones
  - Pagers
  - Laptops, Notebooks, Palmtops
- Portable Test and Measurement
- Medical Equipment
- Audio and Video Switching

### Related Literature

- Technical Brief TB363 “Guidelines for Handling and Processing Moisture Sensitive Surface Mount Devices (SMDs)”
- Application Note AN557 “Recommended Test Procedures for Analog Switches”

**Pinouts** (Note 1)

NOTE:

1. Switches Shown for Logic "0" Input.

**Truth Table**

LOGIC	NC SW	NO SW
0	ON	OFF
1	OFF	ON

NOTE: Logic "0"  $\leq 0.5V$ . Logic "1"  $\geq 1.4V$  with a 3V supply.**Pin Descriptions**

PIN	FUNCTION
V+	System Power Supply Input (+1.65V to +4.5V)
GND	Ground Connection
IN	Digital Control Input
COM	Analog Switch Common Pin
NO	Analog Switch Normally Open Pin
NC	Analog Switch Normally Closed Pin

**Ordering Information**

PART NUMBER	PART MARKING	TEMP. RANGE (°C)	PACKAGE	PKG. DWG. #
ISL54056IRUZ-T* (Note)	GAA	-40 to +85	16 Ld $\mu$ TQFN Tape and Reel (Pb-free)	L16.2.6x1.8A

\*Please refer to TB347 for details on reel specifications.

NOTE: These Intersil Pb-free plastic packaged products employ special Pb-free material sets; molding compounds/die attach materials and NiPdAu plate - e4 termination finish, which is RoHS compliant and compatible with both SnPb and Pb-free soldering operations. Intersil Pb-free products are MSL classified at Pb-free peak reflow temperatures that meet or exceed the Pb-free requirements of IPC/JEDEC J STD-020.

© Copyright Intersil Americas LLC 2006-2007. All Rights Reserved.  
All trademarks and registered trademarks are the property of their respective owners.

For additional products, see [www.intersil.com/en/products.html](http://www.intersil.com/en/products.html)

Intersil products are manufactured, assembled and tested utilizing ISO9001 quality systems as noted  
in the quality certifications found at [www.intersil.com/en/support/qualandreliability.html](http://www.intersil.com/en/support/qualandreliability.html)

*Intersil products are sold by description only. Intersil may modify the circuit design and/or specifications of products at any time without notice, provided that such modification does not, in Intersil's sole judgment, affect the form, fit or function of the product. Accordingly, the reader is cautioned to verify that datasheets are current before placing orders. Information furnished by Intersil is believed to be accurate and reliable. However, no responsibility is assumed by Intersil or its subsidiaries for its use; nor for any infringements of patents or other rights of third parties which may result from its use. No license is granted by implication or otherwise under any patent or patent rights of Intersil or its subsidiaries.*

For information regarding Intersil Corporation and its products, see [www.intersil.com](http://www.intersil.com)

**Absolute Maximum Ratings**

V+ to GND	-0.5 to 5.5V
Input Voltages	
NO, NC, IN (Note 2)	-0.5 to ((V+) + 0.5V)
Output Voltages	
COM (Note 2)	-0.5 to ((V+) + 0.5V)
Continuous Current NO, NC, or COM	±300mA
Peak Current NO, NC, or COM	
(Pulsed 1ms, 10% Duty Cycle, Max)	±500mA
ESD Rating	
Human Body Model (COM <sub>X</sub> )	>9kV
Human Body Model (NO <sub>X</sub> , NC <sub>X</sub> , IN <sub>X</sub> , V+, GND)	>6kV
Machine Model (COM <sub>X</sub> )	>700V
Machine Model (NO <sub>X</sub> , NC <sub>X</sub> , IN <sub>X</sub> , V+, GND)	>300V
Charged Device Model	>1kV

**Thermal Information**

Thermal Resistance (Typical)	$\theta_{JA}$ (°C/W)
$\mu$ TQFN Package (Note 3)	93
Maximum Junction Temperature (Plastic Package)	+150°C
Maximum Storage Temperature Range	-65°C to +150°C
Pb-free reflow profile	see link below
	<a href="http://www.intersil.com/pbfree/Pb-FreeReflow.asp">http://www.intersil.com/pbfree/Pb-FreeReflow.asp</a>

**Operating Conditions**

Temperature Range	
ISL54056IRUZ	-40°C to +85°C

**CAUTION:** Do not operate at or near the maximum ratings listed for extended periods of time. Exposure to such conditions may adversely impact product reliability and result in failures not covered by warranty.

**NOTES:**

- Signals on NC, NO, IN, or COM exceeding V+ or GND are clamped by internal diodes. Limit forward diode current to maximum current ratings.
- $\theta_{JA}$  is measured with the component mounted on a high effective thermal conductivity test board in free air. See Tech Brief TB379 for details.

**Electrical Specifications - 4.3V Supply**

Test Conditions: V+ = +3.9V to +4.5V, GND = 0V, V<sub>INH</sub> = 1.6V, V<sub>INL</sub> = 0.5V (Note 4), Unless Otherwise Specified.

PARAMETER	TEST CONDITIONS	TEMP (°C)	MIN (Notes 5, 8)	TYP	MAX (Notes 5, 8)	UNITS
<b>ANALOG SWITCH CHARACTERISTICS</b>						
Analog Signal Range, V <sub>ANALOG</sub>		Full	0		V+	V
ON-Resistance, r <sub>ON</sub>	V+ = 3.9V, I <sub>COM</sub> = 100mA, V <sub>NO</sub> or V <sub>NC</sub> = 0V to V+	25		0.4	0.55	Ω
	(See Figure 5)	Full		0.45	0.65	Ω
r <sub>ON</sub> Matching Between Channels, Δr <sub>ON</sub>	V+ = 3.9V, I <sub>COM</sub> = 100mA, V <sub>NO</sub> or V <sub>NC</sub> = Voltage at max r <sub>ON</sub> (Note 7)	25		0.05	0.12	Ω
		Full		0.06	0.15	Ω
r <sub>ON</sub> Flatness, r <sub>FLAT(ON)</sub>	V+ = 3.9V, I <sub>COM</sub> = 100mA, V <sub>NO</sub> or V <sub>NC</sub> = 0V to V+	25		0.05	0.15	Ω
	(Note 6)	Full		0.05	0.15	Ω
NO or NC OFF Leakage Current, I <sub>NO(OFF)</sub> or I <sub>NC(OFF)</sub>	V+ = 4.5V, V <sub>COM</sub> = 0.3V, 3V, V <sub>NO</sub> or V <sub>NC</sub> = 3V, 0.3V	25	-70		70	nA
		Full	-165		165	nA
COM ON Leakage Current, I <sub>COM(ON)</sub>	V+ = 4.5V, V <sub>COM</sub> = 0.3V, 3V, or V <sub>NO</sub> or V <sub>NC</sub> = 0.3V, 3V	25	-70		70	nA
		Full	-165		165	nA
<b>DYNAMIC CHARACTERISTICS</b>						
Turn-ON Time, t <sub>ON</sub>	V+ = 3.9V, V <sub>NO</sub> or V <sub>NC</sub> = 3.0V, R <sub>L</sub> = 50Ω, C <sub>L</sub> = 35pF (See Figure 1)	25		33		ns
		Full		38		ns
Turn-OFF Time, t <sub>OFF</sub>	V+ = 3.9V, V <sub>NO</sub> or V <sub>NC</sub> = 3.0V, R <sub>L</sub> = 50Ω, C <sub>L</sub> = 35pF (See Figure 1)	25		16		ns
		Full		21		ns
Break-Before-Make Time Delay, t <sub>D</sub>	V+ = 4.5V, V <sub>NO</sub> or V <sub>NC</sub> = 3.0V, R <sub>L</sub> = 50Ω, C <sub>L</sub> = 35pF (See Figure 3)	Full		3		ns
Charge Injection, Q	C <sub>L</sub> = 1.0nF, V <sub>G</sub> = 0V, R <sub>G</sub> = 0Ω (See Figure 2)	25		248		pC
OFF Isolation	R <sub>L</sub> = 50Ω, C <sub>L</sub> = 5pF, f = 100kHz, V <sub>COM</sub> = 1V <sub>RMS</sub> (See Figure 4)	25		65		dB
Crosstalk (Channel-to-Channel)	R <sub>L</sub> = 50Ω, C <sub>L</sub> = 5pF, f = 100kHz, V <sub>COM</sub> = 1V <sub>RMS</sub> (See Figure 6)	25		-85		dB
Total Harmonic Distortion	f = 20Hz to 20kHz, V <sub>COM</sub> = 2V <sub>P-P</sub> , R <sub>L</sub> = 600Ω	25		0.008		%

**Electrical Specifications - 4.3V Supply**

Test Conditions:  $V_+ = +3.9V$  to  $+4.5V$ ,  $GND = 0V$ ,  $V_{INH} = 1.6V$ ,  $V_{INL} = 0.5V$  (Note 4), Unless Otherwise Specified. **(Continued)**

PARAMETER	TEST CONDITIONS	TEMP (°C)	MIN (Notes 5, 8)	TYP	MAX (Notes 5, 8)	UNITS
NO or NC OFF Capacitance, $C_{OFF}$	$f = 1MHz$ , $V_{NO}$ or $V_{NC} = V_{COM} = 0V$ (See Figure 7)	25		38		pF
COM ON Capacitance, $C_{COM(ON)}$	$f = 1MHz$ , $V_{NO}$ or $V_{NC} = V_{COM} = 0V$ (See Figure 7)	25		102		pF
<b>POWER SUPPLY CHARACTERISTICS</b>						
Power Supply Range		Full	1.65		4.5	V
Positive Supply Current, $I_+$	$V_+ = +4.5V$ , $V_{IN} = 0V$ or $V_+$	25			0.15	$\mu A$
		Full			1.4	$\mu A$
Positive Supply Current, $I_+$	$V_+ = +4.2V$ , $V_{IN} = 2.85V$	25			12	$\mu A$
<b>DIGITAL INPUT CHARACTERISTICS</b>						
Input Voltage Low, $V_{INL}$		Full			0.5	V
Input Voltage High, $V_{INH}$		Full	1.6			V
Input Current, $I_{INH}$ , $I_{INL}$	$V_+ = 4.5V$ , $V_{IN} = 0V$ or $V_+$	Full	-0.5		0.5	$\mu A$

**Electrical Specifications - 3V Supply**

Test Conditions:  $V_+ = +2.7V$  to  $+3.3V$ ,  $GND = 0V$ ,  $V_{INH} = 1.4V$ ,  $V_{INL} = 0.5V$  (Note 4), Unless Otherwise Specified.

PARAMETER	TEST CONDITIONS	TEMP (°C)	MIN (Notes 5, 8)	TYP	MAX (Notes 5, 8)	UNITS
<b>ANALOG SWITCH CHARACTERISTICS</b>						
Analog Signal Range, $V_{ANALOG}$		Full	0		$V_+$	V
ON-Resistance, $r_{ON}$	$V_+ = 2.7V$ , $I_{COM} = 100mA$ , $V_{NO}$ or $V_{NC} = 0V$ to $V_+$ (See Figure 5)	25		0.45	0.55	$\Omega$
		Full			0.65	$\Omega$
$r_{ON}$ Matching Between Channels, $\Delta r_{ON}$	$V_+ = 2.7V$ , $I_{COM} = 100mA$ , $V_{NO}$ or $V_{NC} =$ Voltage at max $r_{ON}$ (Note 7)	25		0.05	0.12	$\Omega$
		Full			0.15	$\Omega$
$r_{ON}$ Flatness, $r_{FLAT(ON)}$	$V_+ = 2.7V$ , $I_{COM} = 100mA$ , $V_{NO}$ or $V_{NC} = 0V$ to $V_+$ (Note 6)	25		0.07	0.15	$\Omega$
		Full			0.15	$\Omega$
NO or NC OFF Leakage Current, $I_{NO(OFF)}$ or $I_{NC(OFF)}$	$V_+ = 3.3V$ , $V_{COM} = 0.3V, 3V$ , $V_{NO}$ or $V_{NC} = 3V, 0.3V$	25		1.1		nA
		Full		30		nA
COM ON Leakage Current, $I_{COM(ON)}$	$V_+ = 3.3V$ , $V_{COM} = 0.3V, 3V$ , or $V_{NO}$ or $V_{NC} = 0.3V, 3V$ , or Floating	25		1.5		nA
		Full		45		nA
<b>DYNAMIC CHARACTERISTICS</b>						
Turn-ON Time, $t_{ON}$	$V_+ = 2.7V$ , $V_{NO}$ or $V_{NC} = 1.5V$ , $R_L = 50\Omega$ , $C_L = 35pF$ (See Figure 1)	25		34		ns
		Full		39		ns
Turn-OFF Time, $t_{OFF}$	$V_+ = 2.7V$ , $V_{NO}$ or $V_{NC} = 1.5V$ , $R_L = 50\Omega$ , $C_L = 35pF$ (See Figure 1)	25		18		ns
		Full		23		ns
Break-Before-Make Time Delay, $t_D$	$V_+ = 3.3V$ , $V_{NO}$ or $V_{NC} = 1.5V$ , $R_L = 50\Omega$ , $C_L = 35pF$ (See Figure 3)	Full		3		ns
Charge Injection, $Q$	$C_L = 1.0nF$ , $V_G = 0V$ , $R_G = 0\Omega$ (See Figure 2)	25		126		pC
OFF Isolation	$R_L = 50\Omega$ , $C_L = 5pF$ , $f = 100kHz$ , $V_{COM} = 1V_{RMS}$ (See Figure 4)	25		65		dB
Crosstalk (Channel-to-Channel)	$R_L = 50\Omega$ , $C_L = 5pF$ , $f = 100kHz$ , $V_{COM} = 1V_{RMS}$ (See Figure 6)	25		-85		dB
Total Harmonic Distortion	$f = 20Hz$ to $20kHz$ , $V_{COM} = 2V_{P-P}$ , $R_L = 600\Omega$	25		0.012		%

**Electrical Specifications - 3V Supply**

Test Conditions:  $V_+ = +2.7V$  to  $+3.3V$ ,  $GND = 0V$ ,  $V_{INH} = 1.4V$ ,  $V_{INL} = 0.5V$  (Note 4), Unless Otherwise Specified. **(Continued)**

PARAMETER	TEST CONDITIONS	TEMP (°C)	MIN (Notes 5, 8)	TYP	MAX (Notes 5, 8)	UNITS
NO or NC OFF Capacitance, $C_{OFF}$	$f = 1MHz$ , $V_{NO}$ or $V_{NC} = V_{COM} = 0V$ (See Figure 7)	25		38		pF
COM ON Capacitance, $C_{COM(ON)}$	$f = 1MHz$ , $V_{NO}$ or $V_{NC} = V_{COM} = 0V$ (See Figure 7)	25		102		pF
<b>POWER SUPPLY CHARACTERISTICS</b>						
Positive Supply Current, $I_+$	$V_+ = 3.6V$ , $V_{IN} = 0V$ or $V_+$	25		0.021		$\mu A$
		Full		0.72		$\mu A$
<b>DIGITAL INPUT CHARACTERISTICS</b>						
Input Voltage Low, $V_{INL}$		Full			0.5	V
Input Voltage High, $V_{INH}$		Full	1.4			V
Input Current, $I_{INH}$ , $I_{INL}$	$V_+ = 3.6V$ , $V_{IN} = 0V$ or $V_+$	Full	-0.5		0.5	$\mu A$

**Electrical Specifications - 1.8V Supply**

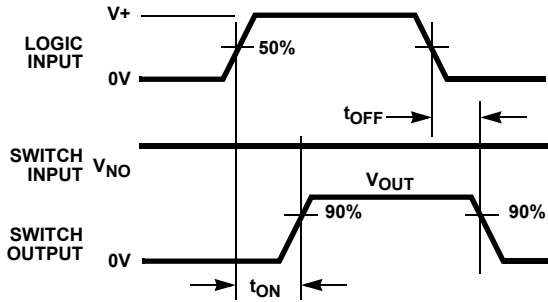
Test Conditions:  $V_+ = +1.65V$  to  $+2V$ ,  $GND = 0V$ ,  $V_{INH} = 1.0V$ ,  $V_{INL} = 0.4V$  (Note 4), Unless Otherwise Specified.

PARAMETER	TEST CONDITIONS	TEMP (°C)	MIN (Notes 5, 8)	TYP	MAX (Notes 5, 8)	UNITS
<b>ANALOG SWITCH CHARACTERISTICS</b>						
Analog Signal Range, $V_{ANALOG}$		Full	0		$V_+$	V
ON-Resistance, $r_{ON}$	$V_+ = 1.8V$ , $I_{COM} = 100mA$ , $V_{NO}$ or $V_{NC} = 0V$ to $V_+$ (See Figure 5)	25		0.65	0.8	$\Omega$
		Full			0.85	$\Omega$
<b>DYNAMIC CHARACTERISTICS</b>						
Turn-ON Time, $t_{ON}$	$V_+ = 1.65V$ , $V_{NO}$ or $V_{NC} = 1.0V$ , $R_L = 50\Omega$ , $C_L = 35pF$ (See Figure 1)	25		50		ns
		Full		55		ns
Turn-OFF Time, $t_{OFF}$	$V_+ = 1.65V$ , $V_{NO}$ or $V_{NC} = 1.0V$ , $R_L = 50\Omega$ , $C_L = 35pF$ (See Figure 1)	25		25		ns
		Full		30		ns
Break-Before-Make Time Delay, $t_D$	$V_+ = 2.0V$ , $V_{NO}$ or $V_{NC} = 1.0V$ , $R_L = 50\Omega$ , $C_L = 35pF$ (See Figure 3)	Full		8		ns
Charge Injection, $Q$	$C_L = 1.0nF$ , $V_G = 0V$ , $R_G = 0\Omega$ (See Figure 2)	25		48		pC
<b>DIGITAL INPUT CHARACTERISTICS</b>						
Input Voltage Low, $V_{INL}$		Full			0.4	V
Input Voltage High, $V_{INH}$		Full	1.0			V
Input Current, $I_{INH}$ , $I_{INL}$	$V_+ = 2.0V$ , $V_{IN} = 0V$ or $V_+$	Full	-0.5		0.5	$\mu A$

## NOTES:

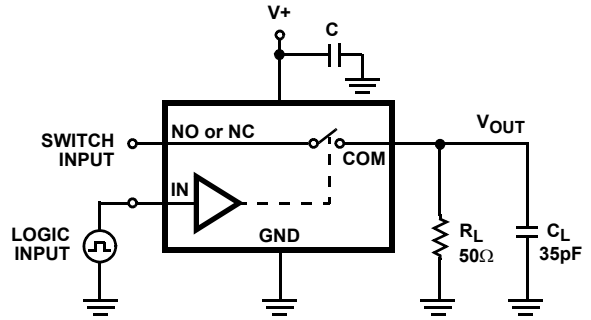
- $V_{IN}$  = input voltage to perform proper function.
- The algebraic convention, whereby the most negative value is a minimum and the most positive a maximum, is used in this data sheet.
- Flatness is defined as the difference between maximum and minimum value of ON-resistance over the specified analog signal range.
- $r_{ON}$  matching between channels is calculated by subtracting the channel with the highest max  $r_{ON}$  value from the channel with lowest max  $r_{ON}$  value, between NC1 and NC2, NC3 and NC4 or between NO1 and NO2, NO3 and NO4.
- Parts are 100% tested at  $+25^\circ C$ . Over-temperature limits established by characterization and are not production tested.

**Test Circuits and Waveforms**



Logic input waveform is inverted for switches that have the opposite logic sense.

FIGURE 1A. MEASUREMENT POINTS



Repeat test for all switches.  $C_L$  includes fixture and stray capacitance.

$$V_{OUT} = V_{(NO \text{ or } NC)} \frac{R_L}{R_L + r_{ON}}$$

FIGURE 1B. TEST CIRCUIT

FIGURE 1. SWITCHING TIMES

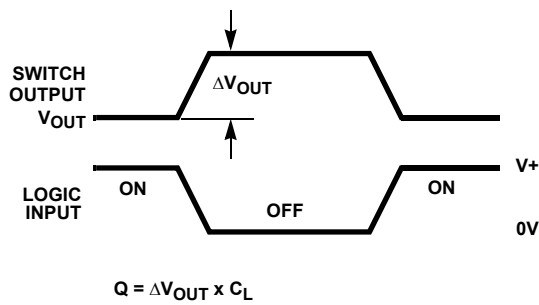


FIGURE 2A. MEASUREMENT POINTS

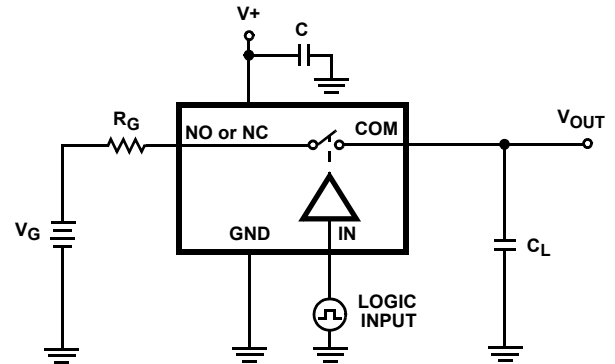


FIGURE 2B. TEST CIRCUIT

FIGURE 2. CHARGE INJECTION

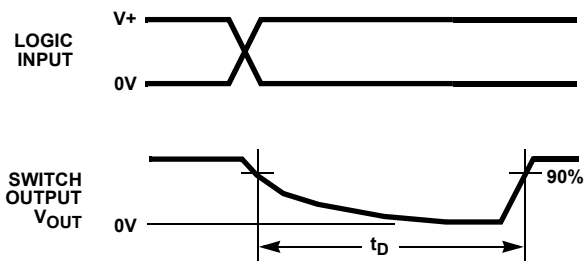
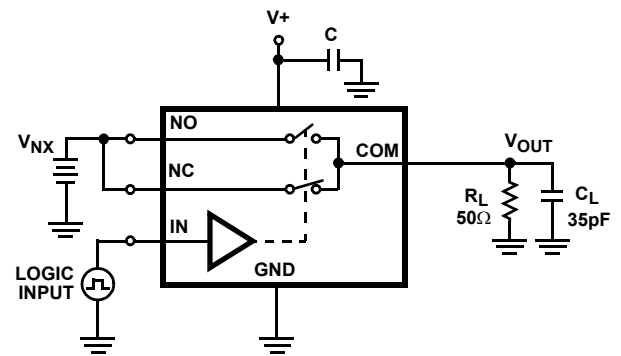


FIGURE 3A. MEASUREMENT POINTS



$C_L$  includes fixture and stray capacitance.

FIGURE 3B. TEST CIRCUIT

FIGURE 3. BREAK-BEFORE-MAKE TIME

## Test Circuits and Waveforms (Continued)

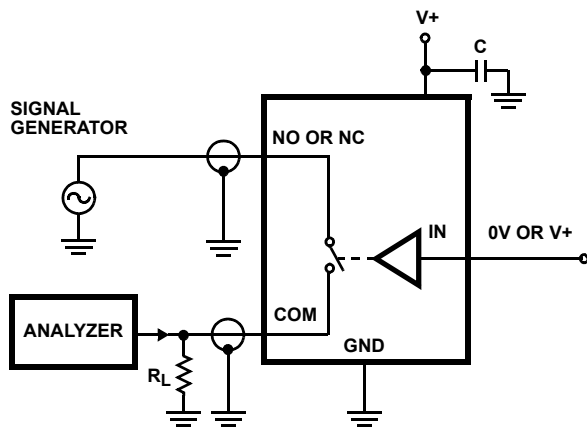


FIGURE 4. OFF ISOLATION TEST CIRCUIT

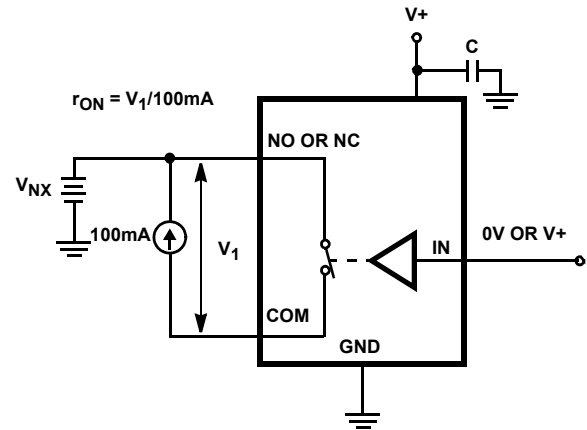
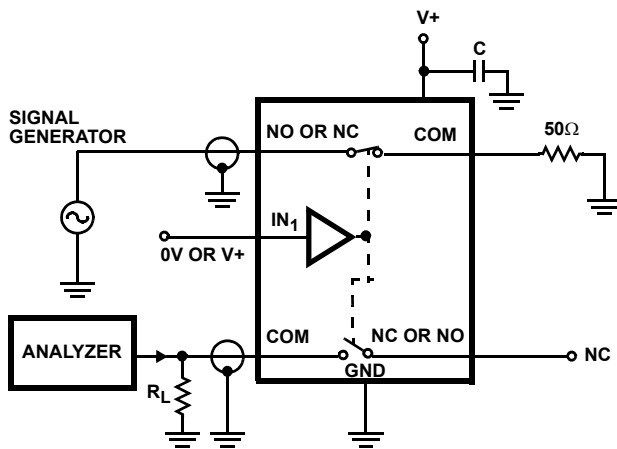
FIGURE 5.  $r_{ON}$  TEST CIRCUIT

FIGURE 6. CROSSTALK TEST CIRCUIT

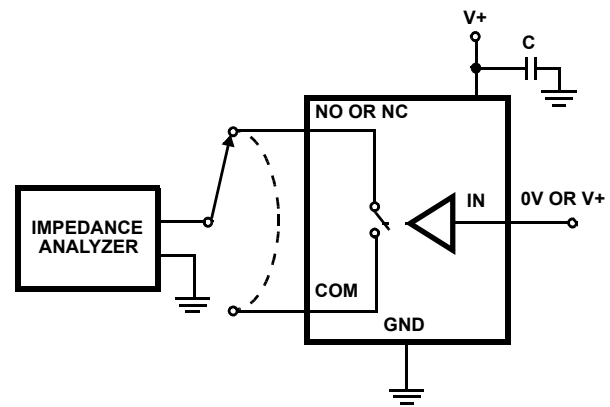


FIGURE 7. CAPACITANCE TEST CIRCUIT

### Detailed Description

The ISL54056 is a bidirectional, quad single pole/double throw (SPDT) analog switch that offers precise switching capability from a single 1.65V to 4.5V supply with low ON-resistance ( $0.39\Omega$ ) and high speed operation ( $t_{ON} = 30\text{ns}$ ,  $t_{OFF} = 16\text{ns}$ ). The device is especially well suited for portable battery powered equipment due to its low operating supply voltage (1.65V), low power consumption ( $6.3\mu\text{W}$  max), low leakage currents (165nA max), and the tiny  $\mu\text{TQFN}$  package. The ultra low ON-resistance and  $r_{ON}$  flatness provide very low insertion loss and distortion to applications that require signal reproduction.

### External V+ Series Resistor

For improved ESD and latch-up immunity, Intersil recommends adding a  $100\Omega$  resistor in series with the V+ power supply pin of the ISL54056 IC (see Figure 8).

During an overvoltage transient event, such as occurs during system level IEC 61000 ESD testing, substrate currents can be generated in the IC that can trigger parasitic SCR structures to turn ON, creating a low impedance path from the V+ power supply to ground. This will result in a significant amount of current flow in the IC, which can potentially create a latch-up state or permanently damage the IC. The external V+ resistor limits the current during this over-stress situation and has been found to prevent latch-up or destructive damage for many overvoltage transient events.

Under normal operation the sub-microamp  $I_{DD}$  current of the IC produces an insignificant voltage drop across the  $100\Omega$  series resistor resulting in no impact to switch operation or performance.

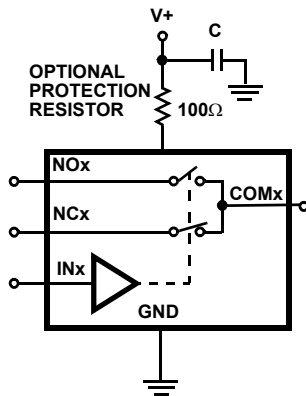


FIGURE 8. V+ SERIES RESISTOR FOR ENHANCED ESD AND LATCH-UP IMMUNITY

### Supply Sequencing and Overvoltage Protection

With any CMOS device, proper power supply sequencing is required to protect the device from excessive input currents which might permanently damage the IC. All I/O pins contain ESD protection diodes from the pin to V+ and to GND (see Figure 9). To prevent forward biasing these diodes, V+ must be applied before any input signals, and the input signal voltages must remain between V+ and GND.

If these conditions cannot be guaranteed, then precautions must be implemented to prohibit the current and voltage at the logic pin and signal pins from exceeding the maximum ratings of the switch. The following two methods can be used to provide additional protection to limit the current in the event that the voltage at a signal pin or logic pin goes below ground or above the V+ rail.

Logic inputs can be protected by adding a 1kΩ resistor in series with the logic input (see Figure 9). The resistor limits the input current below the threshold that produces permanent damage, and the sub-microamp input current produces an insignificant voltage drop during normal operation.

This method is not acceptable for the signal path inputs. Adding a series resistor to the switch input defeats the purpose of using a low  $r_{ON}$  switch. Connecting Schottky diodes to the signal pins as shown in Figure 9 will shunt the fault current to the supply or to ground thereby protecting the switch. These Schottky diodes must be sized to handle the expected fault current.

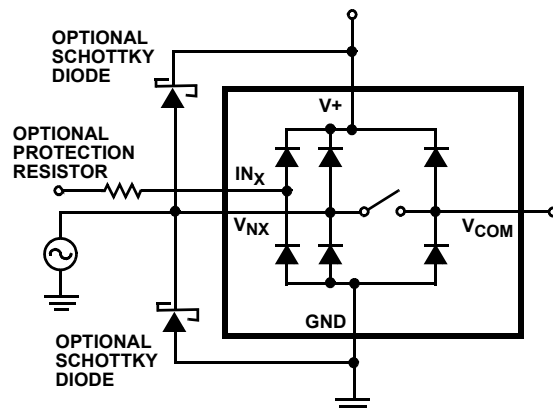


FIGURE 9. OVERVOLTAGE PROTECTION

### Power-Supply Considerations

The ISL54056 construction is typical of most single supply CMOS analog switches, in that they have two supply pins: V+ and GND. V+ and GND drive the internal CMOS switches and set their analog voltage limits. Unlike switches with a 4.7V maximum supply voltage, the ISL54056 5.5V maximum supply voltage provides plenty of room for the 10% tolerance of 4.3V supplies, as well as room for overshoot and noise spikes.

The minimum recommended supply voltage is 1.65V. It is important to note that the input signal range, switching times, and ON-resistance degrade at lower supply voltages. Refer to the “Electrical Specifications” table on page 5 and “Typical Performance Curves” on page 9 for details.

V+ and GND also power the internal logic and level shifters. The level shifters convert the input logic levels to switched V+ and GND signals to drive the analog switch gate terminals.

This family of switches cannot be operated with bipolar supplies, because the input switching point becomes negative in this configuration.

### Logic-Level Thresholds

This switch family is 1.8V CMOS compatible (0.5V and 1.4V) over a supply range of 3.0V to 4.5V (see Figure 19). At 3.0V the  $V_{IL}$  level is about 0.53V. This is still above the 1.8V CMOS guaranteed low output maximum level of 0.5V, but noise margin is reduced.

The digital input stages draw supply current whenever the digital input voltage is not at one of the supply rails. Driving the digital input signals from GND to V+ with a fast transition time minimizes power dissipation.

The ISL54056 has been designed to minimize the supply current whenever the digital input voltage is not driven to the supply rails (0V to V+). For example driving the device with 2.85V logic (0V to 2.85V) while operating with a 4.2V supply the device draws only 12μA of current (see Figure 17 for  $V_{IN} = 2.85V$ ).

**High-Frequency Performance**

In 50Ω systems, the ISL54056 has a -3dB bandwidth of 104MHz (see Figure 22). The frequency response is very consistent over a wide V+ range, and for varying analog signal levels.

An OFF switch acts like a capacitor and passes higher frequencies with less attenuation, resulting in signal feedthrough from a switch’s input to its output. Off isolation is the resistance to this feedthrough, while crosstalk indicates the amount of feedthrough from one switch to another. Figure 23 details the high off isolation and crosstalk rejection provided by this part. At 100kHz, off isolation is about 65dB in 50Ω systems, decreasing approximately 20dB per decade as frequency increases. Higher load impedances decrease off isolation and crosstalk rejection due to the voltage divider action of the switch OFF impedance and the load impedance.

**Leakage Considerations**

Reverse ESD protection diodes are internally connected between each analog-signal pin and both V+ and GND. One of these diodes conducts if any analog signal exceeds V+ or GND.

Virtually all the analog leakage current comes from the ESD diodes to V+ or GND. Although the ESD diodes on a given signal pin are identical and therefore fairly well balanced, they are reverse biased differently. Each is biased by either V+ or GND and the analog signal. This means their leakages will vary as the signal varies. The difference in the two diode leakages to the V+ and GND pins constitutes the analog signal path leakage current. All analog leakage current flows between each pin and one of the supply terminals, not to the other switch terminal. This is why both sides of a given switch can show leakage currents of the same or opposite polarity. There is no connection between the analog signal paths and V+ or GND.

**Typical Performance Curves**  $T_A = +25^\circ\text{C}$ , unless otherwise specified

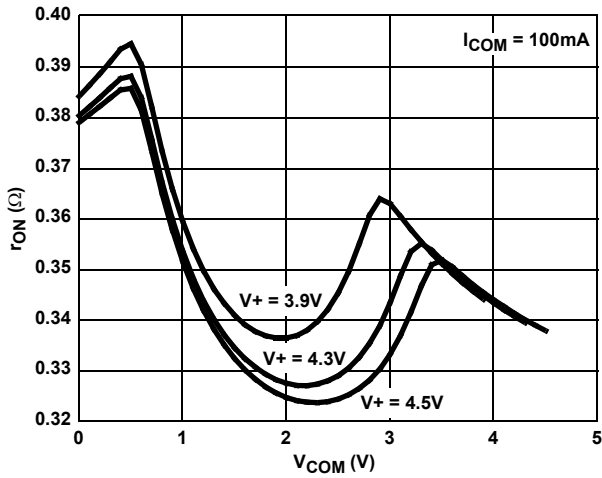


FIGURE 10. ON-RESISTANCE vs SUPPLY VOLTAGE vs SWITCH VOLTAGE

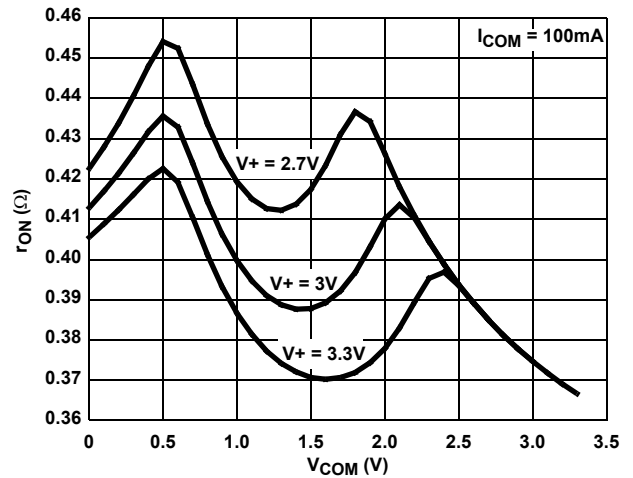


FIGURE 11. ON-RESISTANCE vs SUPPLY VOLTAGE vs SWITCH VOLTAGE

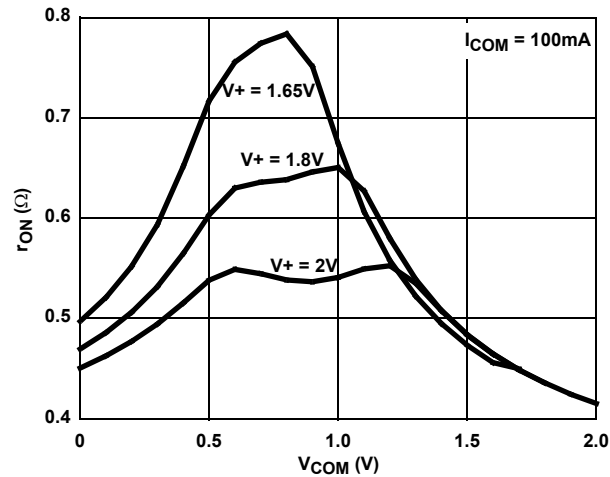


FIGURE 12. ON-RESISTANCE vs SUPPLY VOLTAGE vs SWITCH VOLTAGE

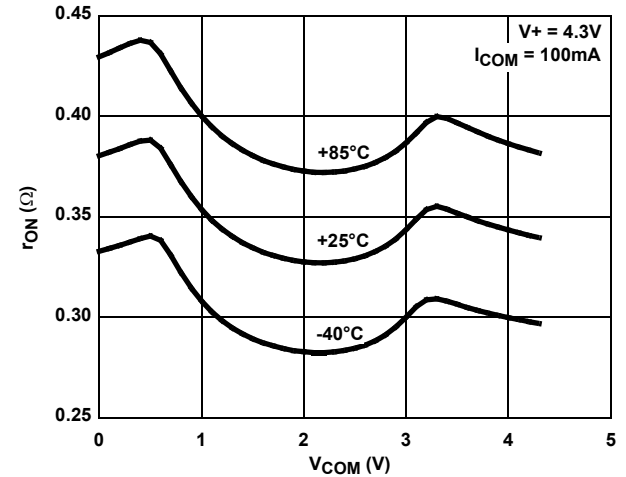


FIGURE 13. ON-RESISTANCE vs SWITCH VOLTAGE

**Typical Performance Curves**  $T_A = +25^\circ\text{C}$ , unless otherwise specified (Continued)

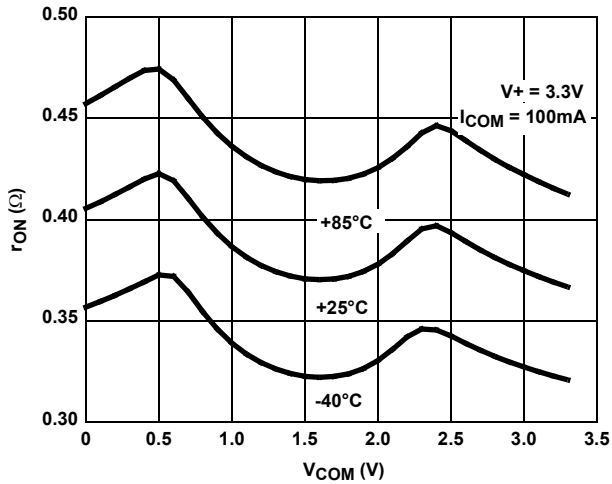


FIGURE 14. ON-RESISTANCE vs SWITCH VOLTAGE

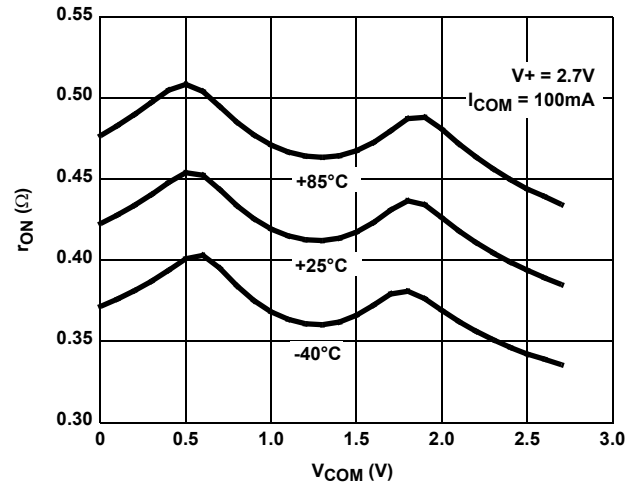


FIGURE 15. ON-RESISTANCE vs SWITCH VOLTAGE

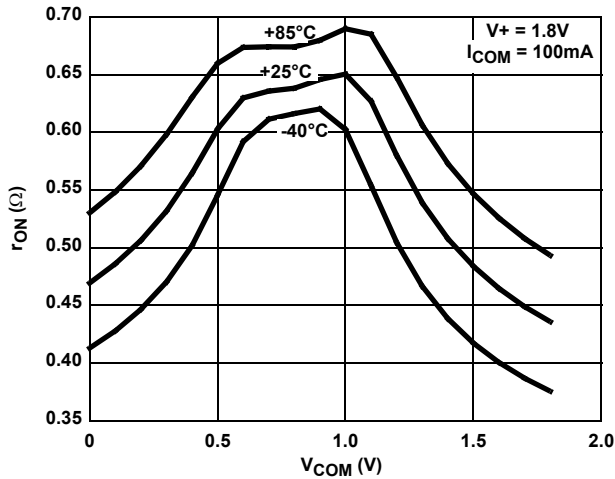


FIGURE 16. ON-RESISTANCE vs SWITCH VOLTAGE

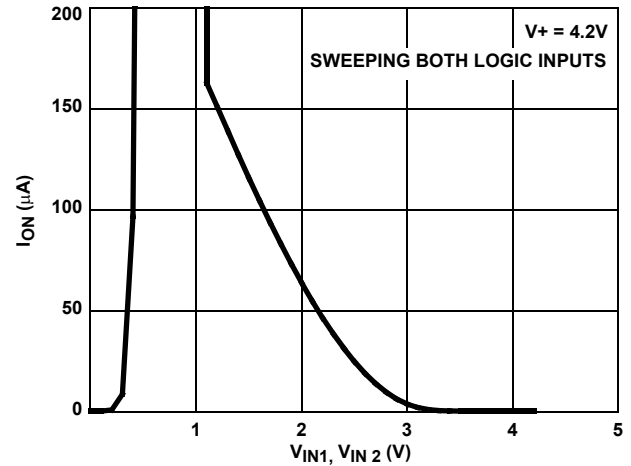


FIGURE 17. SUPPLY CURRENT vs VLOGIC VOLTAGE

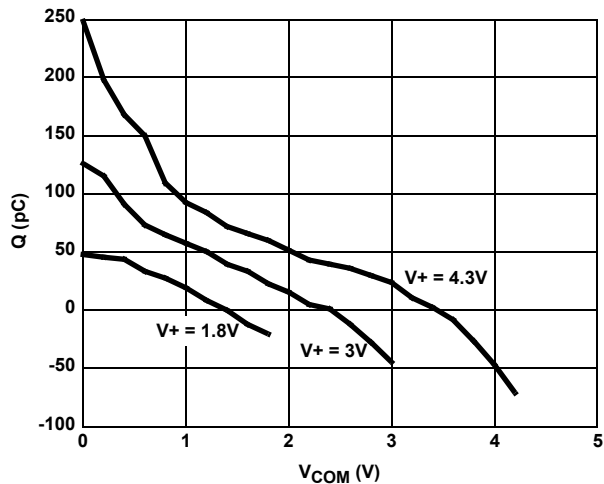


FIGURE 18. CHARGE INJECTION vs SWITCH VOLTAGE

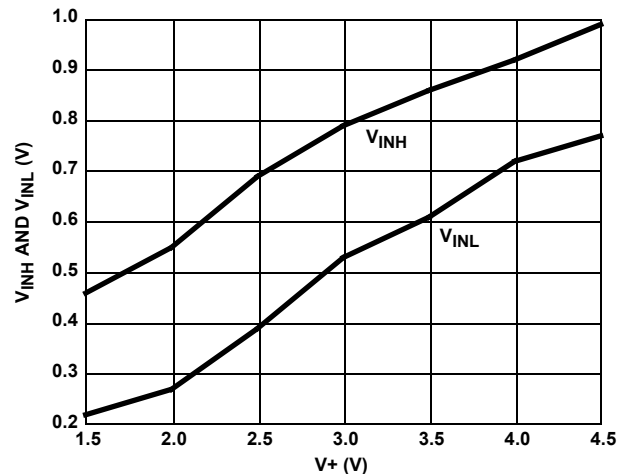


FIGURE 19. DIGITAL SWITCHING POINT vs SUPPLY VOLTAGE

**Typical Performance Curves**  $T_A = +25^\circ\text{C}$ , unless otherwise specified (Continued)

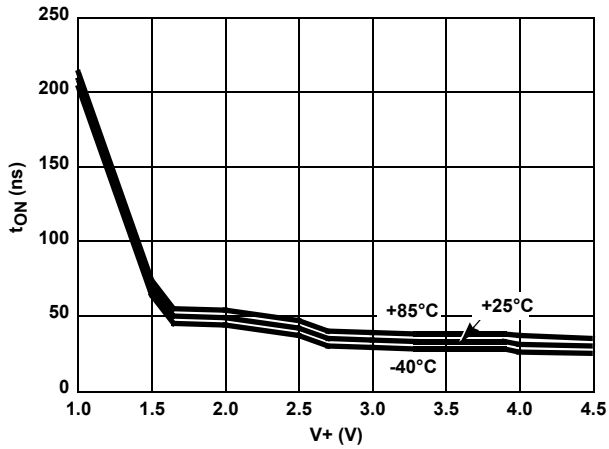


FIGURE 20. TURN-ON TIME vs SUPPLY VOLTAGE

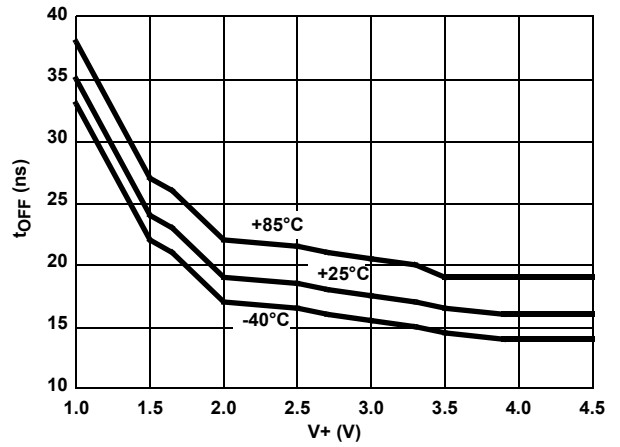


FIGURE 21. TURN-OFF TIME vs SUPPLY VOLTAGE

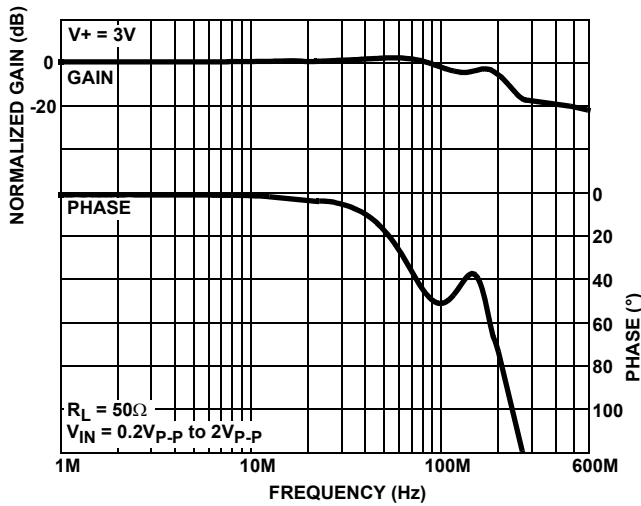


FIGURE 22. FREQUENCY RESPONSE

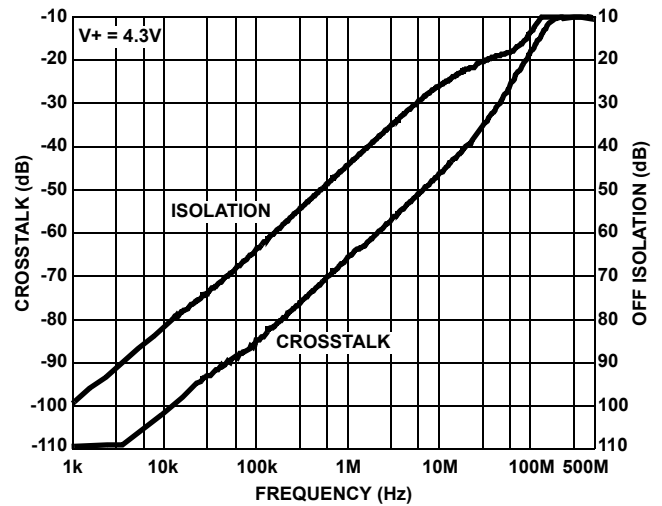


FIGURE 23. CROSSTALK AND OFF ISOLATION

**Die Characteristics**

**SUBSTRATE POTENTIAL (POWERED UP):**

GND

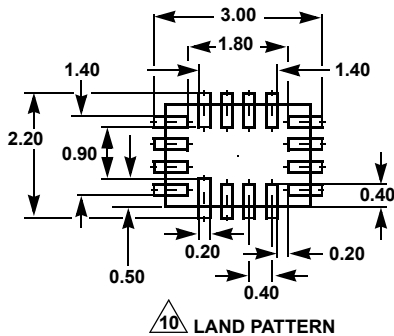
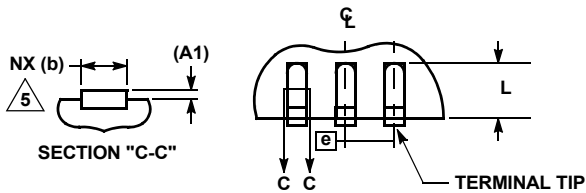
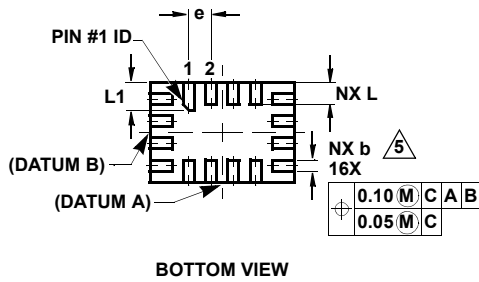
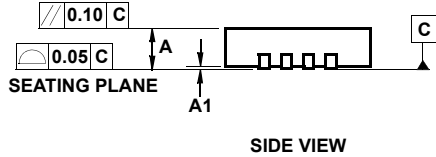
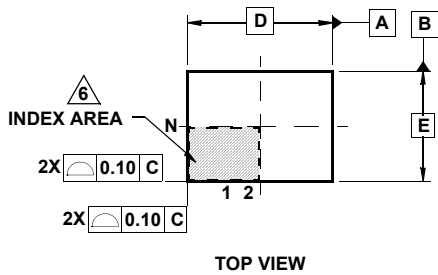
**TRANSISTOR COUNT:**

228

**PROCESS:**

Si Gate CMOS

**Ultra Thin Quad Flat No-Lead Plastic Package (UTQFN)**



**L16.2.6x1.8A**

**16 LEAD ULTRA THIN QUAD FLAT NO-LEAD PLASTIC PACKAGE**

SYMBOL	MILLIMETERS			NOTES
	MIN	NOMINAL	MAX	
A	0.45	0.50	0.55	-
A1	-	-	0.05	-
A3	0.127 REF			-
b	0.15	0.20	0.25	5
D	2.55	2.60	2.65	-
E	1.75	1.80	1.85	-
e	0.40 BSC			-
L	0.35	0.40	0.45	-
L1	0.45	0.50	0.55	-
N	16			2
Nd	4			3
Ne	4			3
θ	0	-	12	4

Rev. 4 8/06

**NOTES:**

1. Dimensioning and tolerancing conform to ASME Y14.5-1994.
2. N is the number of terminals.
3. Nd and Ne refer to the number of terminals on D and E side, respectively.
4. All dimensions are in millimeters. Angles are in degrees.
5. Dimension b applies to the metallized terminal and is measured between 0.15mm and 0.30mm from the terminal tip.
6. The configuration of the pin #1 identifier is optional, but must be located within the zone indicated. The pin #1 identifier may be either a mold or mark feature.
7. Maximum package warpage is 0.05mm.
8. Maximum allowable burrs is 0.076mm in all directions.
9. JEDEC Reference MO-255.
10. For additional information, to assist with the PCB Land Pattern Design effort, see Intersil Technical Brief TB389.

## Looking for pricing, stock, or lifecycle information?

Click below to explore more details on WIN SOURCE:

 [View ISL54056IRUZ-T on WIN SOURCE](#)

 [Intersil Information](#)

## Optimize Your Supply Chain with WIN SOURCE Solutions

-  Global Sourcing Solution
-  Obsolete Management
-  Cost Control Management
-  Shortage Management
-  Alternative Solution
-  Excess Inventory Management