



**THE DATASHEET OF
ISL54053IHZ-T**



ISL54053

Ultra Low ON-Resistance, Low Voltage, Single Supply, SPDT Analog Switch

FN6460
Rev. 3.00
October 19, 2009

The Intersil ISL54053 device is a low ON-resistance, low voltage, bidirectional, single pole/double throw (SPDT) analog switch designed to operate from a single +1.8V to +5.5V supply. Targeted applications include battery powered equipment which benefit from low r_{ON} (0.8Ω) and fast switching speeds ($t_{ON} = 24ns$, $t_{OFF} = 10ns$). The digital logic input is 1.8V logic compatible when using a single +3.0V supply.

Cell phones, for example, often face ASIC functionality limitations. The number of analog input or GPIO pins may be limited and digital geometries are not well suited to analog switch performance. This part may be used to "mux-in" additional functionality while reducing ASIC design risk. The ISL54053 is offered in the 6 Ld 1.2mmx1.0mmx0.5mm μ TDFN and 6 Ld SOT-23 packages, alleviating board space limitations.

The ISL54053 is a committed SPDT that consists of one normally open (NO) and one normally closed (NC) switch. This configuration can also be used as a 2-to-1 multiplexer.

TABLE 1. FEATURES AT A GLANCE

	ISL54053
Number of Switches	1
SW	SPDT or 2-1 MUX
1.8V r_{ON}	2.3 Ω
1.8V t_{ON}/t_{OFF}	68ns/45ns
3V r_{ON}	1.1 Ω
3V t_{ON}/t_{OFF}	29ns/12ns
5V r_{ON}	0.8 Ω
5V t_{ON}/t_{OFF}	24ns/10ns
Packages	6 Ld μ TDFN, 6 Ld SOT-23

Features

- Drop In replacement for the NLAS5123
- ON-resistance (r_{ON})
 - $V_{CC} = +5.0V$ 0.8 Ω
 - $V_{CC} = +3.0V$ 1.1 Ω
 - $V_{CC} = +1.8V$ 2.3 Ω
- r_{ON} matching between channels. 0.004 Ω
- r_{ON} flatness (+4.5V supply) 0.25 Ω
- Single supply operation +1.8V to +5.5V
- Fast switching action (+4.5V supply)
 - t_{ON} 24ns
 - t_{OFF} 10ns
- Guaranteed break-before-make
- ESD HBM rating >6kV
- 1.8V CMOS logic compatible (+3V supply)
- Available in 6 Ld μ TDFN and 6Ld SOT-23 Packages
- Pb-free (RoHS compliant)

Applications

- Battery powered, handheld, and portable equipment
 - Cellular/mobile phones
 - Pagers
 - Laptops, notebooks, palmtops
- Portable test and measurement
- Medical equipment
- Audio and video switching

Related Literature

- Technical Brief TB363 "Guidelines for Handling and Processing Moisture Sensitive Surface Mount Devices (SMDs)"

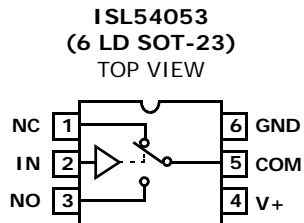
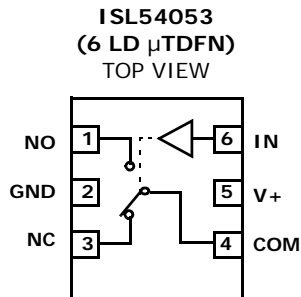
Ordering Information

PART NUMBER (Notes 1, 4)	PART MARKING	TEMP. RANGE (°C)	PACKAGE (Pb-Free)	PKG. DWG. #
ISL54053IRUZ-T (Note 2)	C	-40 to +85	6 Ld (0.40mm pitch) 1.2x1.0x0.5 μTDFN, Tape and Reel	L6.1.2x1.0A
ISL54053IHZ-T (Note 3)	4053	-40 to +85	6 Ld SOT-23, Tape and Reel	MDP0038

NOTES:

1. Please refer to [TB347](#) for details on reel specifications.
2. These Intersil Pb-free plastic packaged products employ special Pb-free material sets; molding compounds/die attach materials and NiPdAu plate - e4 termination finish, which is RoHS compliant and compatible with both SnPb and Pb-free soldering operations. Intersil Pb-free products are MSL classified at Pb-free peak reflow temperatures that meet or exceed the Pb-free requirements of IPC/JEDEC J STD-020.
3. These Intersil Pb-free plastic packaged products employ special Pb-free material sets, molding compounds/die attach materials, and 100% matte tin plate plus anneal (e3 termination finish, which is RoHS compliant and compatible with both SnPb and Pb-free soldering operations). Intersil Pb-free products are MSL classified at Pb-free peak reflow temperatures that meet or exceed the Pb-free requirements of IPC/JEDEC J STD-020.
4. For Moisture Sensitivity Level (MSL), please see device information page for [ISL54053](#). For more information on MSL please see techbrief [TB363](#).

Pin Configurations (Note 5)



NOTE:

5. Switches Shown for Logic "0" Input.

Pin Descriptions

PIN	FUNCTION
V+	System Power Supply Input (+1.8V to +5.5V)
GND	Ground Connection
IN	Digital Control Input
COM	Analog Switch Common Pin
NO	Analog Switch Normally Open Pin
NC	Analog Switch Normally Closed Pin

Truth Table

LOGIC	PIN NC	PIN NO
0	On	Off
1	Off	On

NOTE: Logic "0" $\leq 0.5V$. Logic "1" $\geq 1.4V$ with a 2.0V to 5.0V supply.

Absolute Maximum Ratings

V+ to GND	-0.5V to 6.5V
Input Voltages	
NO, NC, IN (Note 6)	-0.5 to ((V+) + 0.5V)
Output Voltages	
COM (Note 6)	-0.5 to ((V+) + 0.5V)
Continuous Current NO, NC, or COM	±300mA
Peak Current NO, NC, or COM	
(Pulsed 1ms, 10% Duty Cycle, Max)	±500mA
ESD Rating	
Human Body Model	>6kV
Machine Model	>200V
Charged Device Model	>2.2kV

Thermal Information

Thermal Resistance (Typical)	θ_{JA} (°C/W)	θ_{JC} (°C/W)
6 Ld μ TDFN (Note 7)	175	N/A
6 Ld SOT-23 (Notes 7, 8)	260	120
Maximum Junction Temperature (Plastic Package)	+150°C	
Maximum Storage Temperature Range	-65°C to +150°C	
Pb-Free Reflow Profile	see link below http://www.intersil.com/pbfree/Pb-FreeReflow.asp	

Operating Conditions

V+ (Positive DC Supply Voltage)	1.8V to 5.5V
Analog Signal Range	0V to V+
V _{IN} (Digital Logic Input Voltage (IN))	0V to V+
Temperature Range	-40°C to +85°C

CAUTION: Do not operate at or near the maximum ratings listed for extended periods of time. Exposure to such conditions may adversely impact product reliability and result in failures not covered by warranty.

NOTES:

- Signals on NC, NO, IN, or COM exceeding V+ or GND are clamped by internal diodes. Limit forward diode current to maximum current ratings.
- θ_{JA} is measured with the component mounted on a high effective thermal conductivity test board in free air. See Tech Brief TB379 for details.
- For θ_{JC} , the "case temp" location is taken at the package top center.

Electrical Specifications - 5V Supply Test Conditions: V+ = +4.5V to +5.5V, GND = 0V, V_{INH} = 2.4V, V_{INL} = 0.8V (Note 9), Unless Otherwise Specified. **Boldface limits apply over the operating temperature range, -40°C to +85°C.**

PARAMETER	TEST CONDITIONS	TEMP (°C)	MIN (Notes 10, 11)	TYP	MAX (Notes 10, 11)	UNITS
ANALOG SWITCH CHARACTERISTICS						
Analog Signal Range, V _{ANALOG}		Full	0	-	V+	V
ON-Resistance, r _{ON}	V+ = 4.5V, I _{COM} = 100mA, V _{NO} or V _{NC} = 0V to V+, (See Figure 5, Note 13)	25	-	0.86	-	Ω
		Full	-	1	-	Ω
r _{ON} Matching Between Channels, Δr _{ON}	V+ = 4.5V, I _{COM} = 100mA, V _{NO} or V _{NC} = 2.5V, (Note 13)	25	-	0.004	-	Ω
		Full	-	0.004	-	Ω
r _{ON} Flatness, r _{FLAT(ON)}	V+ = 4.5V, I _{COM} = 100mA, V _{NO} or V _{NC} = 0V to V+, (Notes 12, 13)	25	-	0.25	-	Ω
		Full	-	0.27	-	Ω
NO or NC OFF Leakage Current, I _{NO(OFF)} or I _{NC(OFF)}	V+ = 5.5V, V _{COM} = 0.3V, 5V, V _{NO} or V _{NC} = 5V, 0.3V	25	-10	5	10	nA
		Full	-150	-	150	nA
COM ON Leakage Current, I _{COM(ON)}	V+ = 5.5V, V _{COM} = 0.3V, 5V, or V _{NO} or V _{NC} = 0.3V, 5V, or floating	25	-20	9	20	nA
		Full	-300	-	300	nA
DYNAMIC CHARACTERISTICS						
Turn-ON Time, t _{ON}	V+ = 4.5V, V _{NO} or V _{NC} = 3.0V, R _L = 50Ω, C _L = 35pF (See Figure 1, Note 13)	25	-	24	-	ns
		Full	-	30	-	ns
Turn-OFF Time, t _{OFF}	V+ = 4.5V, V _{NO} or V _{NC} = 3.0V, R _L = 50Ω, C _L = 35pF (See Figure 1, Note 13)	25	-	10	-	ns
		Full	-	15	-	ns
Break-Before-Make Time Delay, t _D	V+ = 5.5V, V _{NO} or V _{NC} = 3.0V, R _L = 50Ω, C _L = 35pF (See Figure 3, Note 13)	Full	-	10	-	ns
Charge Injection, Q	V _G = 0V, R _G = 0Ω, C _L = 1.0nF (See Figure 2)	25	-	26	-	pC
OFF Isolation	R _L = 50Ω, C _L = 5pF, f = 100kHz, V _{COM} = 1V _{RMS} (See Figure 4)	25	-	80	-	dB
Crosstalk (Channel-to-Channel)	R _L = 50Ω, C _L = 5pF, f = 100kHz, V _{COM} = 1V _{RMS} (See Figure 6)	25	-	-83	-	dB

Electrical Specifications - 5V Supply Test Conditions: $V_+ = +4.5V$ to $+5.5V$, $GND = 0V$, $V_{INH} = 2.4V$, $V_{INL} = 0.8V$ (Note 9), Unless Otherwise Specified. **Boldface limits apply over the operating temperature range, $-40^\circ C$ to $+85^\circ C$.** (Continued)

PARAMETER	TEST CONDITIONS	TEMP (°C)	MIN (Notes 10, 11)	TYP	MAX (Notes 10, 11)	UNITS
Total Harmonic Distortion	$f = 20Hz$ to $20kHz$, $V_{COM} = 0.5V_{P-P}$, $R_L = 600\Omega$	25	-	0.03	-	%
-3dB Bandwidth	$R_L = 50\Omega$	25	-	190	-	MHz
NO or NC OFF Capacitance, C_{OFF}	$V_+ = 4.5V$, $f = 1MHz$, V_{NO} or $V_{NC} = V_{COM} = 0V$ (See Figure 7)	25	-	16	-	pF
COM ON Capacitance, $C_{COM(ON)}$	$V_+ = 4.5V$, $f = 1MHz$, V_{NO} or $V_{NC} = V_{COM} = 0V$ (See Figure 7)	25	-	48	-	pF
POWER SUPPLY CHARACTERISTICS						
Power Supply Range		Full	1.8	-	5.5	V
Positive Supply Current, I_+	$V_+ = 5.5V$, $V_{IN} = 0V$ or V_+	25	-	0.075	0.1	μA
		Full	-	-	2.5	μA
DIGITAL INPUT CHARACTERISTICS						
Input Voltage Low, V_{INL}		Full	-	-	0.8	V
Input Voltage High, V_{INH}		Full	2.4	-	-	V
Input Current, I_{INH} , I_{INL}	$V_+ = 5.5V$, $V_{IN} = 0V$ or V_+	Full	-0.1	-	0.1	μA

Electrical Specifications - 3V Supply Test Conditions: $V_+ = +2.7V$ to $+3.6V$, $GND = 0V$, $V_{INH} = 1.4V$, $V_{INL} = 0.5V$ (Note 9), Unless Otherwise Specified. **Boldface limits apply over the operating temperature range, $-40^\circ C$ to $+85^\circ C$.**

PARAMETER	TEST CONDITIONS	TEMP (°C)	MIN (Notes 10, 11)	TYP	MAX (Notes 10, 11)	UNITS
ANALOG SWITCH CHARACTERISTICS						
Analog Signal Range, V_{ANALOG}		Full	0	-	V_+	V
ON-Resistance, r_{ON} , ($\mu TDFN$)	$V_+ = 3.0V$, $I_{COM} = 100mA$, V_{NO} or $V_{NC} = 0V$ to V_+ , (See Figure 5, Note 13)	25	-	1.1	1.2	Ω
		Full	-	-	1.5	Ω
ON-Resistance, r_{ON} , (SOT-23)	$V_+ = 3.0V$, $I_{COM} = 100mA$, V_{NO} or $V_{NC} = 0V$ to V_+ , (See Figure 5, Note 13)	25	-	1.1	1.3	Ω
		Full	-	-	1.6	Ω
r_{ON} Matching Between Channels, Δr_{ON}	$V_+ = 3.0V$, $I_{COM} = 100mA$, V_{NO} or $V_{NC} = 1.5V$, (Note 13)	25	-	0.004	0.14	Ω
		Full	-	-	0.14	Ω
r_{ON} Flatness, $r_{FLAT(ON)}$	$V_+ = 3.0V$, $I_{COM} = 100mA$, V_{NO} or $V_{NC} = 0V$ to V_+ , (Notes 12, 13)	25	-	0.33	0.35	Ω
		Full	-	-	0.4	Ω
DYNAMIC CHARACTERISTICS						
Turn-ON Time, t_{ON}	$V_+ = 2.7V$, V_{NO} or $V_{NC} = 1.5V$, $R_L = 50\Omega$, $C_L = 35pF$ (See Figure 1, Note 13)	25	-	29	-	ns
		Full	-	35	-	ns
Turn-OFF Time, t_{OFF}	$V_+ = 2.7V$, V_{NO} or $V_{NC} = 1.5V$, $R_L = 50\Omega$, $C_L = 35pF$ (See Figure 1, Note 13)	25	-	12	-	ns
		Full	-	17	-	ns
Break-Before-Make Time Delay, t_D	$V_+ = 3.6V$, V_{NO} or $V_{NC} = 1.5V$, $R_L = 50\Omega$, $C_L = 35pF$ (See Figure 3, Note 13)	Full	-	10	-	ns
Charge Injection, Q	$V_G = 0V$, $R_G = 0\Omega$, $C_L = 1.0nF$ (See Figure 2)	25	-	32	-	pC
OFF Isolation	$R_L = 50\Omega$, $C_L = 5pF$, $f = 100kHz$, $V_{COM} = 1V_{RMS}$ (See Figure 4)	25	-	80	-	dB
Crosstalk (Channel-to-Channel)	$R_L = 50\Omega$, $C_L = 5pF$, $f = 100kHz$, $V_{COM} = 1V_{RMS}$ (See Figure 6)	25	-	-83	-	dB
Total Harmonic Distortion	$f = 20Hz$ to $20kHz$, $V_{COM} = 0.5V_{P-P}$, $R_L = 600\Omega$	25	-	0.03	-	%
-3dB Bandwidth	$R_L = 50\Omega$	25	-	190	-	MHz
NO or NC OFF Capacitance, C_{OFF}	$f = 1MHz$, V_{NO} or $V_{NC} = V_{COM} = 0V$ (See Figure 7)	25	-	16	-	pF

Electrical Specifications - 3V Supply Test Conditions: $V_+ = +2.7V$ to $+3.6V$, $GND = 0V$, $V_{INH} = 1.4V$, $V_{INL} = 0.5V$ (Note 9), Unless Otherwise Specified. **Boldface limits apply over the operating temperature range, $-40^\circ C$ to $+85^\circ C$.** (Continued)

PARAMETER	TEST CONDITIONS	TEMP (°C)	MIN (Notes 10, 11)	TYP	MAX (Notes 10, 11)	UNITS
COM ON Capacitance, $C_{COM(ON)}$	$f = 1MHz$, V_{NO} or $V_{NC} = V_{COM} = 0V$ (See Figure 7)	25	-	48	-	pF
DIGITAL INPUT CHARACTERISTICS						
Input Voltage Low, V_{INL}		Full	-	-	0.5	V
Input Voltage High, V_{INH}		Full	1.4	-	-	V
Input Current, I_{INH} , I_{INL}	$V_+ = 3.6V$, $V_{IN} = 0V$ or V_+	Full	-0.1	-	0.1	μA

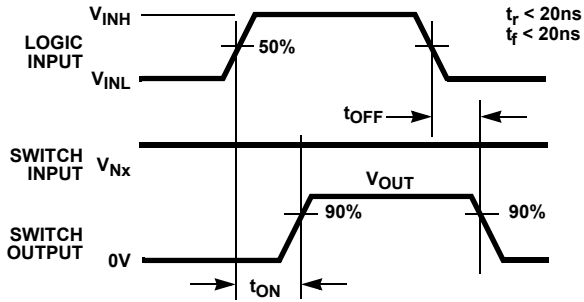
Electrical Specifications - 1.8V Supply Test Conditions: $V_+ = +1.8V$, $GND = 0V$, $V_{INH} = 1V$, $V_{INL} = 0.4V$ (Note 9), Unless Otherwise Specified. **Boldface limits apply over the operating temperature range, $-40^\circ C$ to $+85^\circ C$.**

PARAMETER	TEST CONDITIONS	TEMP (°C)	MIN (Notes 10, 11)	TYP	MAX (Notes 10, 11)	UNITS
ANALOG SWITCH CHARACTERISTICS						
Analog Signal Range, V_{ANALOG}		Full	0	-	V_+	V
ON-Resistance, r_{ON}	$V_+ = 1.8V$, $I_{COM} = 10mA$, V_{NO} or $V_{NC} = 0V$ to V_+ , (See Figure 5, Note 13)	25	-	2.33	-	Ω
		Full	-	2.54	-	Ω
DYNAMIC CHARACTERISTICS						
Turn-ON Time, t_{ON}	$V_+ = 1.8V$, V_{NO} or $V_{NC} = 1.5V$, $R_L = 50\Omega$, $C_L = 35pF$ (See Figure 1, Note 13)	25	-	68	-	ns
		Full	-	93	-	ns
Turn-OFF Time, t_{OFF}	$V_+ = 1.8V$, V_{NO} or $V_{NC} = 1.5V$, $R_L = 50\Omega$, $C_L = 35pF$ (See Figure 1, Note 13)	25	-	45	-	ns
		Full	-	71	-	ns
Break-Before-Make Time Delay, t_D	$V_+ = 1.8V$, V_{NO} or $V_{NC} = 1.5V$, $R_L = 50\Omega$, $C_L = 35pF$ (See Figure 3, Note 13)	Full	-	15	-	ns
Charge Injection, Q	$V_G = 0$, $R_G = 0\Omega$, $C_L = 1.0nF$ (See Figure 2)	25	-	18	-	pC
DIGITAL INPUT CHARACTERISTICS						
Input Voltage Low, V_{INL}		Full	-	-	0.4	V
Input Voltage High, V_{INH}		Full	1	-	-	V

NOTES:

9. V_{IN} = input voltage to perform proper function.
10. The algebraic convention, whereby the most negative value is a minimum and the most positive a maximum, is used in this data sheet.
11. Parameters with MIN and/or MAX limits are 100% tested at $+25^\circ C$, unless otherwise specified. Temperature limits established by characterization and are not production tested.
12. Flatness is defined as the difference between maximum and minimum value of on-resistance over the specified analog signal range.
13. Limits established by characterization and are not production tested.

Test Circuits and Waveforms



Logic input waveform is inverted for switches that have the opposite logic sense.

FIGURE 1A. MEASUREMENT POINTS

FIGURE 1. SWITCHING TIMES

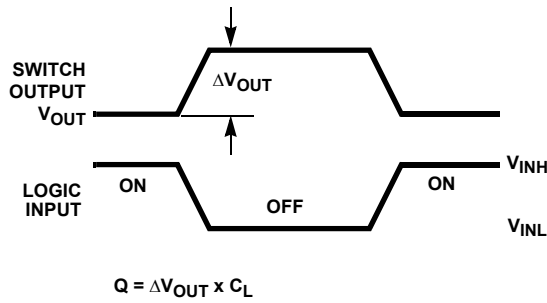


FIGURE 2A. MEASUREMENT POINTS

FIGURE 2. CHARGE INJECTION

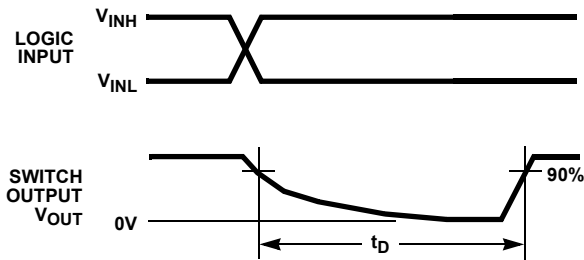
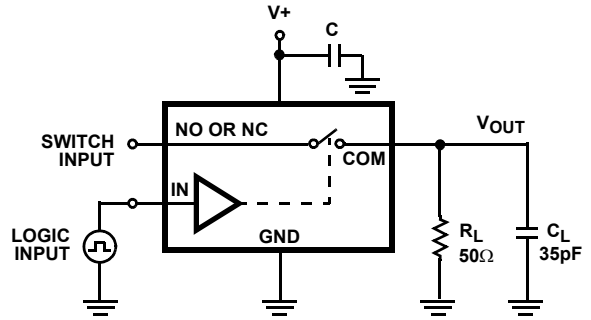


FIGURE 3A. MEASUREMENT POINTS

FIGURE 3. BREAK-BEFORE-MAKE TIME



Repeat test for all switches. C_L includes fixture and stray capacitance.

$$V_{OUT} = V_{(NO \text{ or } NC)} \frac{R_L}{R_L + r_{(ON)}}$$

FIGURE 1B. TEST CIRCUIT

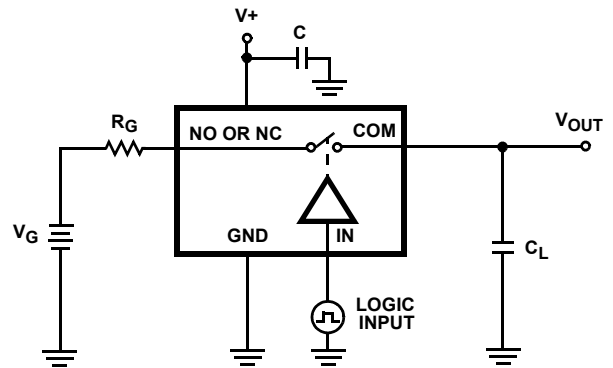
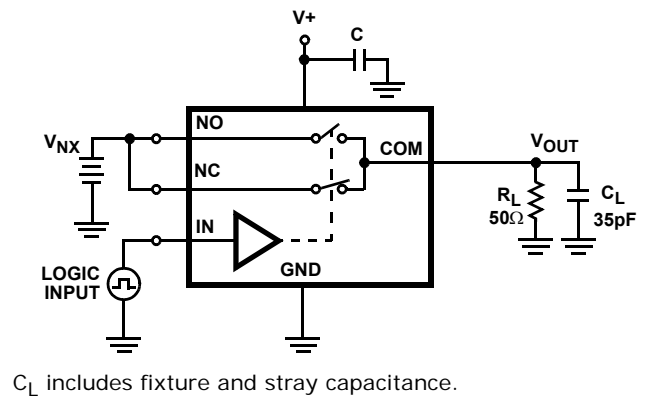


FIGURE 2B. TEST CIRCUIT



C_L includes fixture and stray capacitance.

FIGURE 3B. TEST CIRCUIT

Test Circuits and Waveforms (Continued)

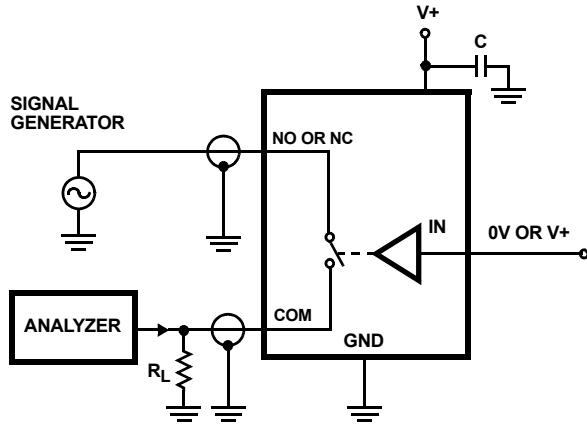


FIGURE 4. OFF ISOLATION TEST CIRCUIT

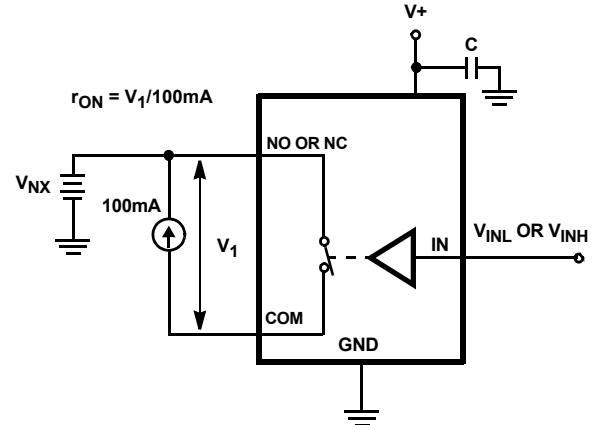
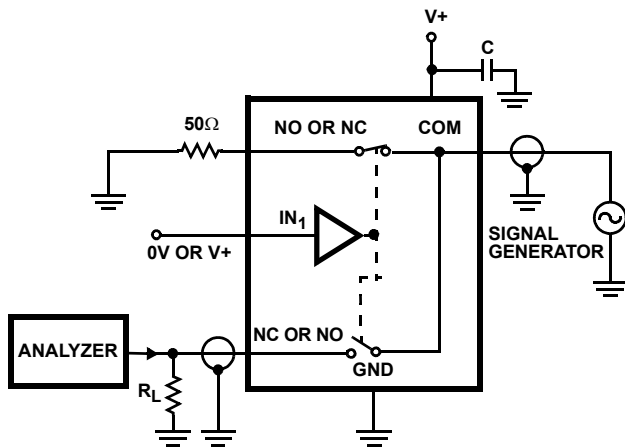
FIGURE 5. r_{ON} TEST CIRCUIT

FIGURE 6. CROSSTALK TEST CIRCUIT

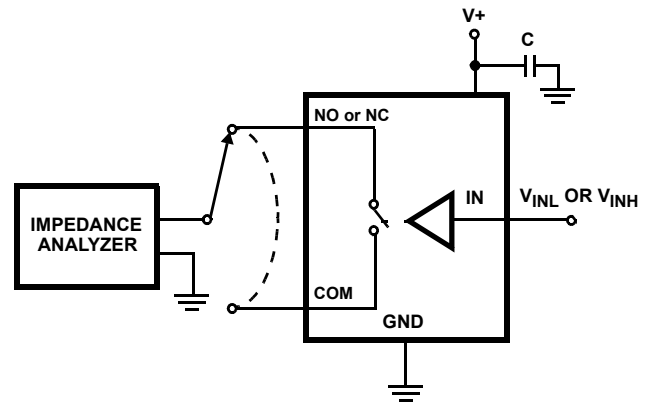


FIGURE 7. CAPACITANCE TEST CIRCUIT

Detailed Description

The ISL54053 is a bidirectional, single pole/double throw (SPDT) analog switch which offers precise switching capability from a single 1.8V to 5.5V supply with low ON-resistance (0.8Ω) and high speed operation ($t_{ON} = 24\text{ns}$, $t_{OFF} = 10\text{ns}$). The device is especially well suited for portable battery powered equipment due to its low operating supply voltage (1.8V), low power consumption (5.5μW), low leakage currents (300nA max) and the small μTDFN and SOT-23 packages. The low on-resistance and r_{ON} flatness provide very low insertion loss and distortion to application that require signal reproduction.

Supply Sequencing and Overvoltage Protection

With any CMOS device, proper power supply sequencing is required to protect the device from excessive input currents which might permanently damage the IC. All I/O pins contain ESD protection diodes from the pin to $V+$ and to GND (see Figure 8). To prevent forward biasing these diodes, $V+$ must be applied before any input signals, and the input signal voltages must remain between $V+$ and GND.

If these conditions cannot be guaranteed, then precautions must be implemented to prohibit the current and voltage at the logic pin and signal pins from exceeding the maximum ratings of the switch. The following two methods can be used to provide additional protection to limit the current in the event that the voltage at a signal pin or logic pin goes below ground or above the $V+$ rail.

Logic inputs can be protected by adding a 1kΩ resistor in series with the logic input (see Figure 8). The resistor limits the input current below the threshold that produces permanent damage, and the sub-microamp input current produces an insignificant voltage drop during normal operation.

This method is not acceptable for the signal path inputs. Adding a series resistor to the switch input defeats the purpose of using a low r_{ON} switch. Connecting schottky diodes to the signal pins (as shown in Figure 8) will shunt the fault current to the supply or to ground thereby protecting the switch. These schottky diodes must be sized to handle the expected fault current.

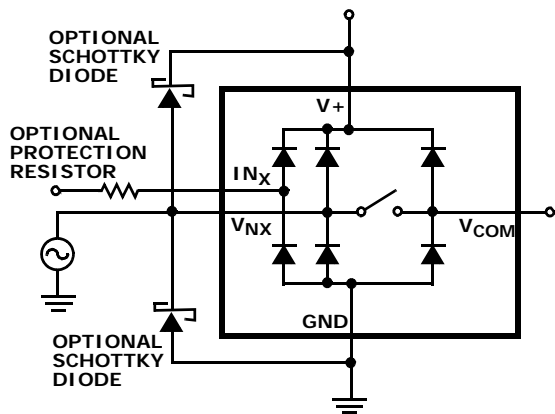


FIGURE 8. OVERVOLTAGE PROTECTION

Power-Supply Considerations

The ISL54053 construction is typical of most single supply CMOS analog switches, in that they have two supply pins: V+ and GND. V+ and GND drive the internal CMOS switches and set their analog voltage limits. Unlike switches with a 4.5V maximum supply voltage, the ISL54053 5.5V maximum supply voltage provides plenty of room for the 10% tolerance of 4.3V supplies, as well as room for overshoot and noise spikes.

The minimum recommended supply voltage is 1.8V but the part will operate with a supply below 1.8V. It is important to note that the input signal range, switching times, and ON-resistance degrade at lower supply voltages. Refer to the “Electrical Specifications” tables starting on page 3 and “Typical Performance Curves” on page 9 for details.

V+ and GND also power the internal logic and level shifters. The level shifters convert the input logic levels to switched V+ and GND signals to drive the analog switch gate terminals.

This family of switches cannot be operated with bipolar supplies because the input switching point becomes negative in this configuration.

Logic-Level Thresholds

This switch family is 1.8V CMOS compatible (0.5V and 1.4V) over a supply range of 2V to 5V (see Figure 15). At 5V the V_{IH} level is about 1.2V. This is still below the 1.8V CMOS guaranteed high output minimum level of 1.4V, but noise margin is reduced.

The digital input stages draw supply current whenever the digital input voltage is not at one of the supply rails. Driving the digital input signals from GND to V+ with a fast transition time minimizes power dissipation.

High-Frequency Performance

In 50Ω systems, the ISL54053 has a -3dB bandwidth of 190MHz (see Figure 16). The frequency response is very consistent over a wide V+ range, and for varying analog signal levels.

An OFF switch acts like a capacitor and passes higher frequencies with less attenuation, resulting in signal feedthrough from a switch’s input to its output. Off isolation is the resistance to this feedthrough, while crosstalk indicates the amount of feedthrough from one switch to another. Figure 17 details the high off isolation and crosstalk rejection provided by this family. At 100kHz, off isolation is about 80dB in 50Ω systems, decreasing approximately 20dB per decade as frequency increases. Higher load impedances decrease off isolation and crosstalk rejection due to the voltage divider action of the switch OFF impedance and the load impedance.

Leakage Considerations

ESD protection diodes are internally connected between each analog-signal pin and both V+ and GND. One of these diodes conducts if any analog signal exceeds V+ or GND.

Virtually all the analog leakage current comes from the ESD diodes to V+ or GND. Although the ESD diodes on a given signal pin are identical and therefore fairly well balanced, they are reverse biased differently. Each is biased by either V+ or GND and the analog signal. This means their leakages will vary as the signal varies. The difference in the two diode leakages to the V+ and GND pins constitutes the analog-signal-path leakage current. All analog leakage current flows between each pin and one of the supply terminals, not to the other switch terminal. This is why both sides of a given switch can show leakage currents of the same or opposite polarity. There is no connection between the analog signal paths and V+ or GND.

Typical Performance Curves $T_A = +25^\circ\text{C}$, Unless Otherwise Specified.

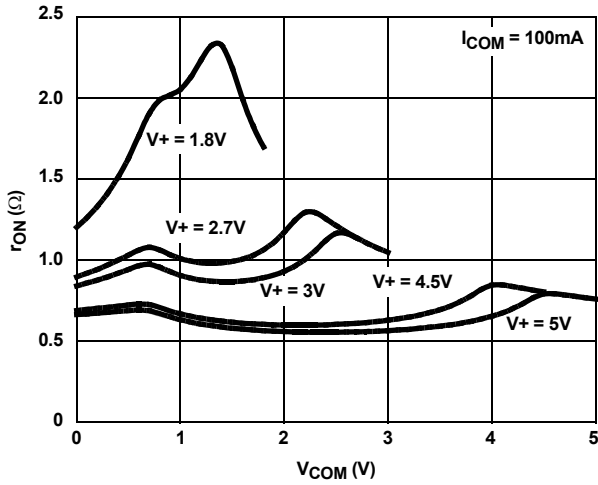


FIGURE 9. ON-RESISTANCE vs SUPPLY VOLTAGE vs SWITCH VOLTAGE

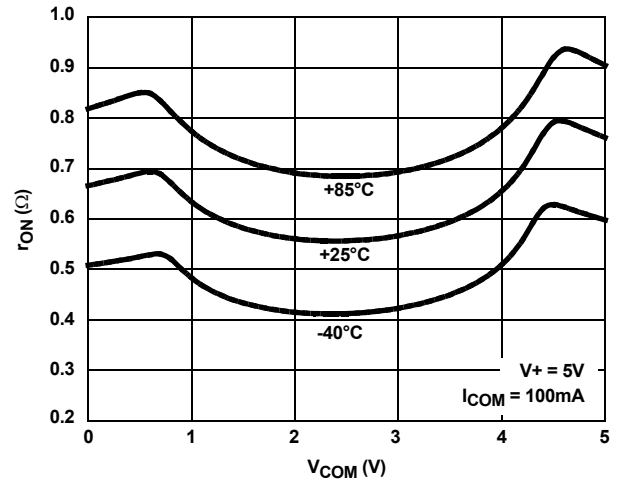


FIGURE 10. ON-RESISTANCE vs SWITCH VOLTAGE

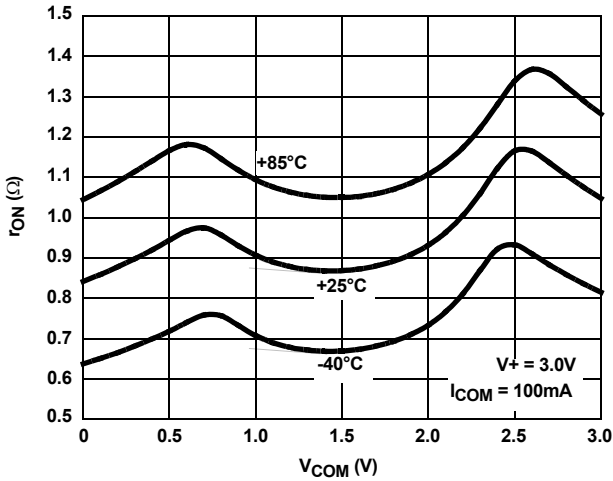


FIGURE 11. ON-RESISTANCE vs SWITCH VOLTAGE

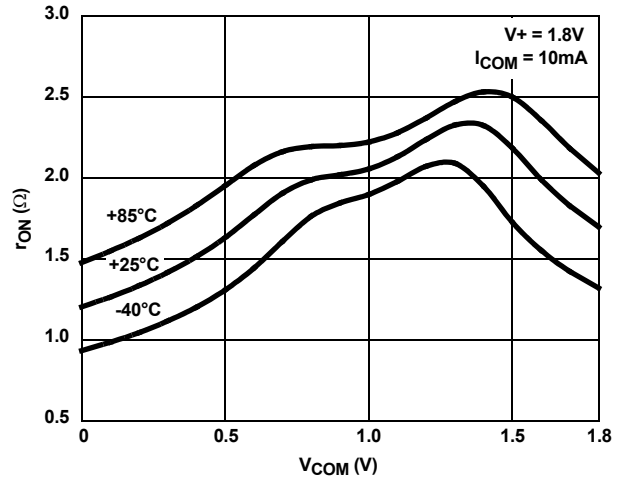


FIGURE 12. ON-RESISTANCE vs SWITCH VOLTAGE

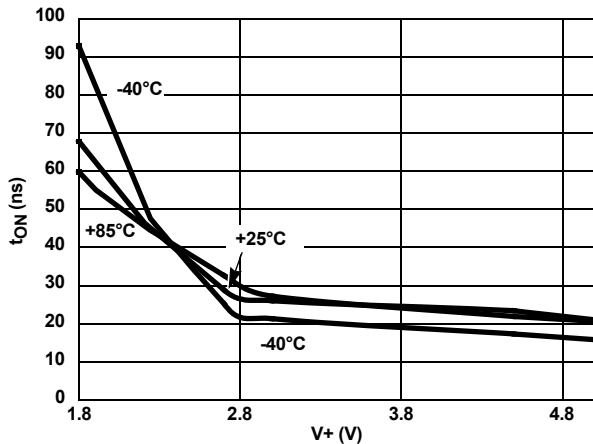


FIGURE 13. TURN-ON TIME vs SUPPLY VOLTAGE

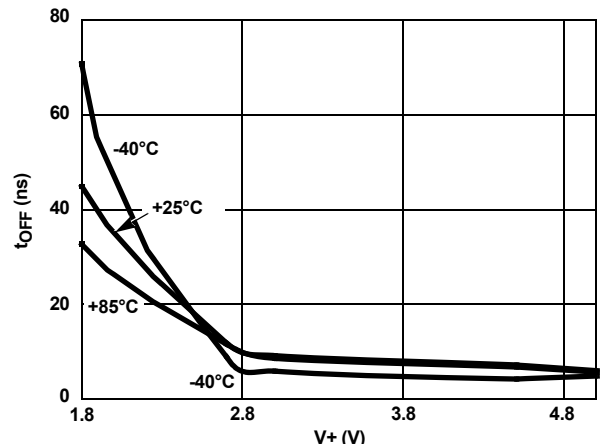


FIGURE 14. TURN-OFF TIME vs SUPPLY VOLTAGE

Typical Performance Curves $T_A = +25^\circ\text{C}$, Unless Otherwise Specified. (Continued)

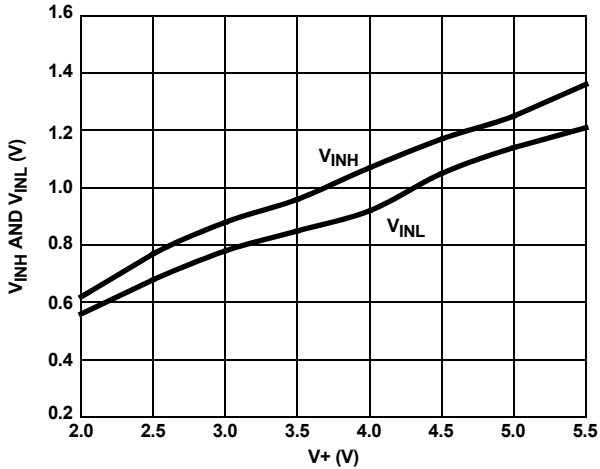


FIGURE 15. DIGITAL SWITCHING POINT vs SUPPLY VOLTAGE

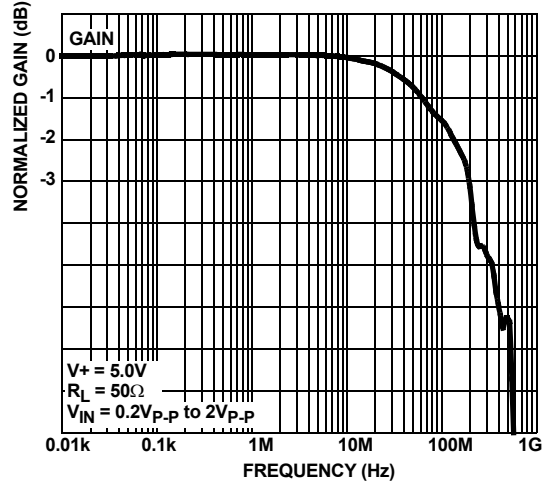


FIGURE 16. FREQUENCY RESPONSE

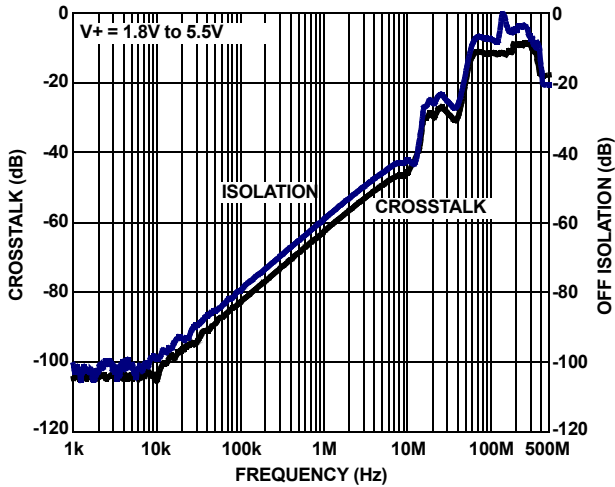


FIGURE 17. CROSSTALK AND OFF ISOLATION

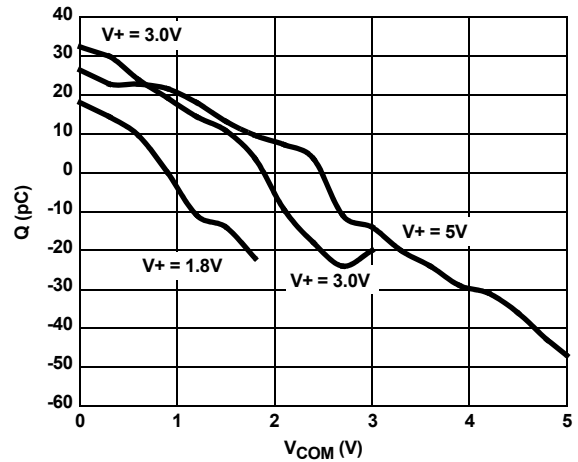


FIGURE 18. CHARGE INJECTION vs SWITCH VOLTAGE

Die Characteristics

SUBSTRATE POTENTIAL (POWERED UP):

GND

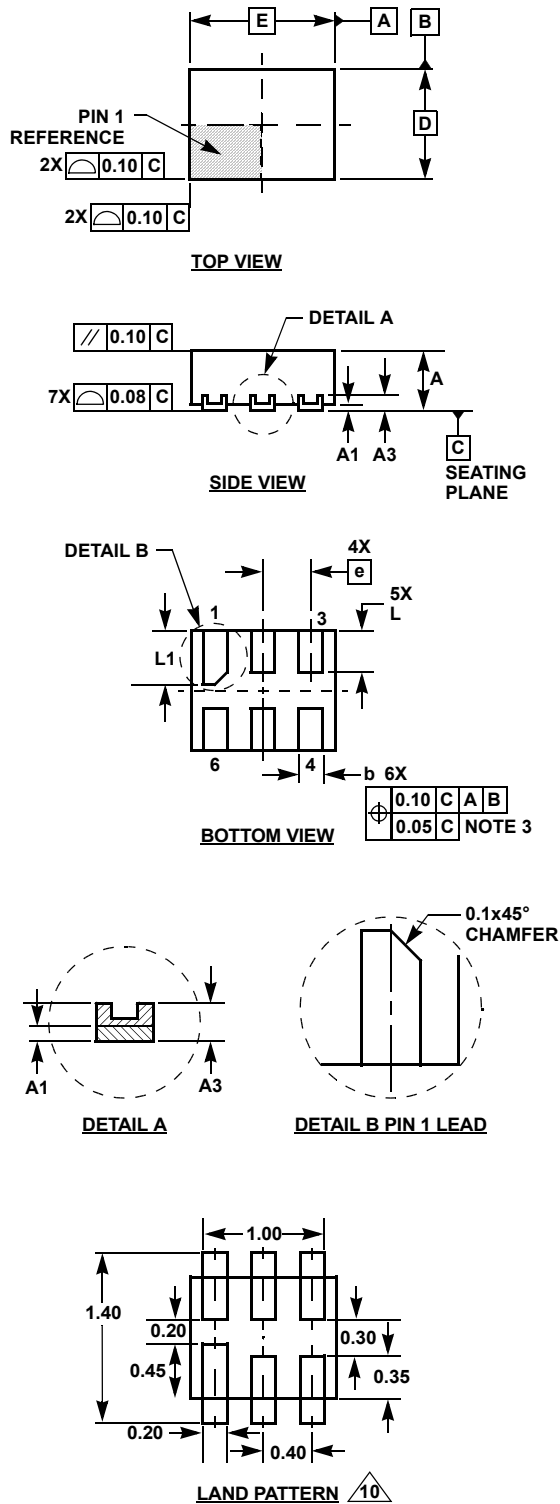
TRANSISTOR COUNT:

57

PROCESS:

Submicron CMOS

Ultra Thin Dual Flat No-Lead Plastic Package (UTDFN)



L6.1.2x1.0A

6 LEAD ULTRA THIN DUAL FLAT NO-LEAD PLASTIC PACKAGE

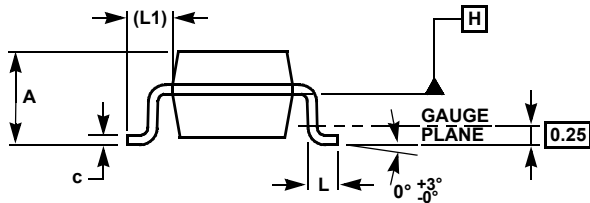
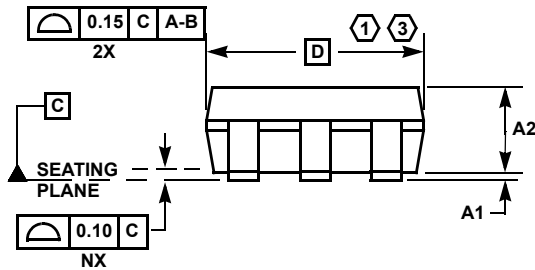
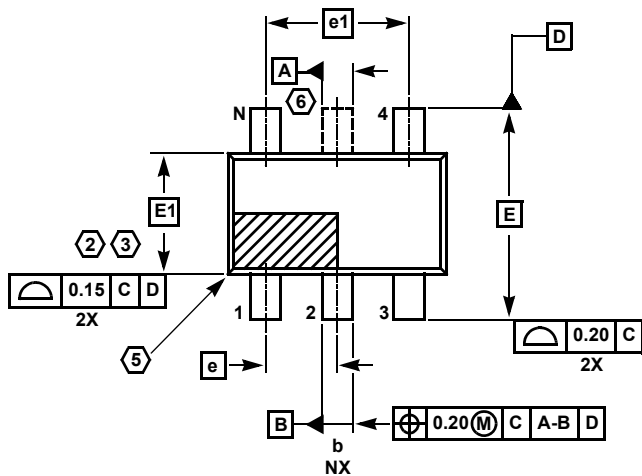
SYMBOL	MILLIMETERS			NOTES
	MIN	NOMINAL	MAX	
A	0.45	0.50	0.55	-
A1	-	-	0.05	-
A3	0.127 REF			-
b	0.15	0.20	0.25	5
D	0.95	1.00	1.05	-
E	1.15	1.20	1.25	-
e	0.40 BSC			-
L	0.30	0.35	0.40	-
L1	0.40	0.45	0.50	-
N	6			2
Ne	3			3
θ	0	-	12	4

Rev. 2 8/06

NOTES:

1. Dimensioning and tolerancing conform to ASME Y14.5-1994.
2. N is the number of terminals.
3. Ne refers to the number of terminals on E side.
4. All dimensions are in millimeters. Angles are in degrees.
5. Dimension b applies to the metallized terminal and is measured between 0.15mm and 0.30mm from the terminal tip.
6. The configuration of the pin #1 identifier is optional, but must be located within the zone indicated. The pin #1 identifier may be either a mold or mark feature.
7. Maximum package warpage is 0.05mm.
8. Maximum allowable burrs is 0.076mm in all directions.
9. JEDEC Reference MO-255.
10. For additional information, to assist with the PCB Land Pattern Design effort, see Intersil Technical Brief TB389.

SOT-23 Package Family



MDP0038

SOT-23 PACKAGE FAMILY

SYMBOL	MILLIMETERS		TOLERANCE
	SOT23-5	SOT23-6	
A	1.45	1.45	MAX
A1	0.10	0.10	±0.05
A2	1.14	1.14	±0.15
b	0.40	0.40	±0.05
c	0.14	0.14	±0.06
D	2.90	2.90	Basic
E	2.80	2.80	Basic
E1	1.60	1.60	Basic
e	0.95	0.95	Basic
e1	1.90	1.90	Basic
L	0.45	0.45	±0.10
L1	0.60	0.60	Reference
N	5	6	Reference

Rev. F 2/07

NOTES:

1. Plastic or metal protrusions of 0.25mm maximum per side are not included.
2. Plastic interlead protrusions of 0.25mm maximum per side are not included.
3. This dimension is measured at Datum Plane "H".
4. Dimensioning and tolerancing per ASME Y14.5M-1994.
5. Index area - Pin #1 I.D. will be located within the indicated zone (SOT23-6 only).
6. SOT23-5 version has no center lead (shown as a dashed line).

© Copyright Intersil Americas LLC 2007-2009. All Rights Reserved.
 All trademarks and registered trademarks are the property of their respective owners.

For additional products, see www.intersil.com/en/products.html

Intersil products are manufactured, assembled and tested utilizing ISO9001 quality systems as noted in the quality certifications found at www.intersil.com/en/support/qualandreliability.html

Intersil products are sold by description only. Intersil may modify the circuit design and/or specifications of products at any time without notice, provided that such modification does not, in Intersil's sole judgment, affect the form, fit or function of the product. Accordingly, the reader is cautioned to verify that datasheets are current before placing orders. Information furnished by Intersil is believed to be accurate and reliable. However, no responsibility is assumed by Intersil or its subsidiaries for its use; nor for any infringements of patents or other rights of third parties which may result from its use. No license is granted by implication or otherwise under any patent or patent rights of Intersil or its subsidiaries.

For information regarding Intersil Corporation and its products, see www.intersil.com

Looking for pricing, stock, or lifecycle information?

Click below to explore more details on WIN SOURCE:

 [View ISL54053IHZ-T on WIN SOURCE](#)

 [Intersil Information](#)

Optimize Your Supply Chain with WIN SOURCE Solutions

-  Global Sourcing Solution
-  Obsolete Management
-  Cost Control Management
-  Shortage Management
-  Alternative Solution
-  Excess Inventory Management