

ISL45041

TFT-LCD I2C Programmable VCOM Calibrator

FN6189
Rev 6.00
Apr 22, 2016

The V_{COM} voltage of an LCD panel needs to be adjusted to remove flicker. The ISL45041 part provides a digital interface to control the sink current output that attaches to an external voltage divider. The increase in output sink current lowers the voltage on the external divider, which is applied to an external V_{COM} buffer amplifier. The desired V_{COM} setting is loaded from an external source via a standard 2-wire I²C serial interface. At power-up, the part automatically comes up at the last programmed EEPROM setting.

An external resistor attaches to the SET pin and sets the full-scale sink current that determines the lowest voltage of the external voltage divider.

The ISL45041 is available in an 8 Ld 3mmx3mm TDFN package with a maximum thickness of 0.8mm for ultra thin LCD panel design.

An evaluation kit complete with software to control the DCP from a computer is available. Reference Application Note [AN1275](#) and "Ordering Information" on [page 2](#).

Features

- 128-step adjustable sink current output
- 2.25V to 3.6V logic supply voltage operating range (2.6V minimum programming voltage)
- 4.5V to 18V analog supply voltage operating range (10.8V minimum programming voltage)
- I²C interface with addresses 100111x and 100110x
- On-chip 7-Bit EEPROM
- Output adjustment SET pin
- Output guaranteed monotonic over-temperature
- Thin 8 Ld 3mmx3mm DFN (0.8mm max)
- Pb-free (RoHS compliant)

Applications

- LCD panels

Related Literature

- [AN1208](#) "LCD screens don't flicker - or do they?"
- [AN1275](#), "ISL45041EVAL1Z User's Manual"

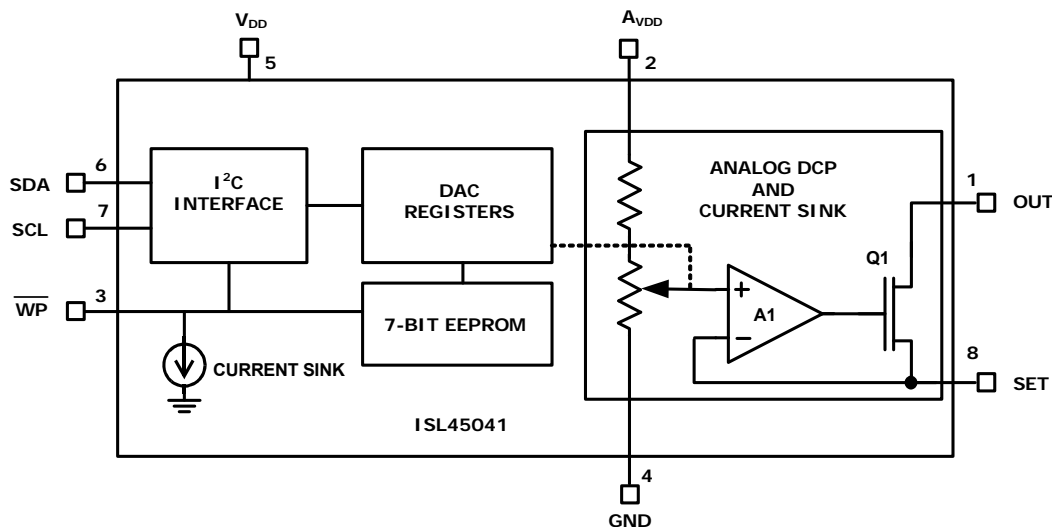
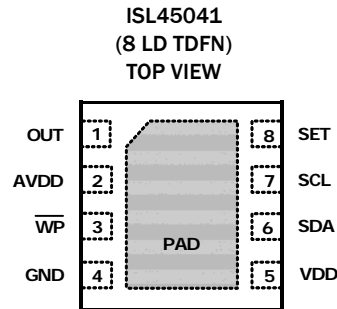

FIGURE 1. BLOCK DIAGRAM

Pin Configuration



Pin Descriptions

PIN NUMBER	PIN NAME	TYPE	PULL U/D	FUNCTION
1	OUT	Output		Adjustable Sink Current Output Pin. The current that sinks into the OUT pin is equal to the DAC setting times the maximum adjustable sink current divided by 128. See SET pin function description for the maximum adjustable sink current setting.
2	AVDD	Supply		High-Voltage Analog Supply. Bypass to GND with 0.1 μ F capacitor.
3	$\overline{\text{WP}}$	Input	Pull-Down	Write Protect. Active Low. To enable programming, connect to 0.7*V _{DD} supply or greater. The $\overline{\text{WP}}$ pin is designed for static control. It has an internal pull-down current sink. To avoid the possibly overwriting the EEPROM contents, no frequency above 1Hz should be applied to this input. Care should be taken to avoid any glitches on the input. When removing or applying mechanical jumpers, always ensure the V _{DD} power is off. A high to low transition on the $\overline{\text{WP}}$ pin results in the register contents being loaded with EEPROM data.
4	GND	Supply		Ground connection
5	VDD	Supply		Digital power supply input. Bypass to GND with 0.1 μ F capacitor.
6	SDA	In/Out		I ² C Serial Data Input and Output
7	SCL	Input		I ² C Clock Input
8	SET	Analog		Maximum Sink Current Adjustment Point. Connect a resistor from SET to GND to set the maximum adjustable sink current of the OUT pin. The maximum adjustable sink current is equal to (AV _{DD} /20) divided by RSET.
	Pad	Power		Thermal pad. Electrically connected to GND. Connect to ground plane on PCB to maximize thermal performance.

Ordering Information

PART NUMBER (Notes 1, 2, 3)	PART MARKING	TEMP. RANGE (°C)	PACKAGE (Pb-Free)	PKG. DWG. #
ISL45041IRZ	041Z	0 to +85	8 Ld 3x3 TDFN	L8.3x3A
ISL45041EVAL1Z	Evaluation Board			

NOTES:

- Add "-T*" suffix for tape and reel. Please refer to [TB347](#) for details on reel specifications.
- These Intersil Pb-free plastic packaged products employ special Pb-free material sets, molding compounds/die attach materials, and 100% matte tin plate plus anneal (e3 termination finish, which is RoHS compliant and compatible with both SnPb and Pb-free soldering operations). Intersil Pb-free products are MSL classified at Pb-free peak reflow temperatures that meet or exceed the Pb-free requirements of IPC/JEDEC J STD-020.
- For Moisture Sensitivity Level (MSL), please see device information page for [ISL45041](#). For more information on MSL, please see Technical Brief [TB363](#).

Absolute Maximum Ratings

VDD to GND	+4V
Input Voltages to GND	
SET	-0.3V to +4V
AVDD	-0.3V to +20V
Output Voltages to GND	
OUT	-0.3V to +AVDD
ESD Rating	
Human Body Model	
Device (Tested per JESD22-A114E)	2kV
Input Pins (SCL, SDA) (Tested per JESD22-A114E)	4kV

Thermal Information

Thermal Resistance (Typical)	θ_{JA} (°C/W)	θ_{JC} (°C/W)
8 Ld TDFN Package (Notes 4, 5)	53	11
Moisture Sensitivity (see Technical Brief TB363)		
All Packages	Level 2	
Maximum Junction Temperature (Plastic Package)	+150°C	
Maximum Storage Temperature Range	-65°C to +150°C	
Pb-free reflow profile	see TB493	

Operating Conditions

Temperature Range 0°C to +85°C

CAUTION: Do not operate at or near the maximum ratings listed for extended periods of time. Exposure to such conditions may adversely impact product reliability and result in failures not covered by warranty.

NOTES:

- θ_{JA} is measured in free air with the component mounted on a high effective thermal conductivity test board with “direct attach” features. See Tech Brief TB379.
- For θ_{JC} , the “case temp” location is the center of the exposed metal pad on the package underside.

Electrical Specifications Test Conditions: $V_{DD} = 3.3V$, $AV_{DD} = 18V$, $R_{SET} = 5k\Omega$, $R1 = 10k\Omega$, $R2 = 10k\Omega$; (See Figure 2) Unless otherwise specified. Typicals are at $T_A = +25^\circ C$. **Boldface limits apply across the operating temperature range, 0°C to +85°C.**

PARAMETER	SYMBOL	TEST CONDITIONS	MIN (Note 6)	TYP	MAX (Note 6)	UNITS
POWER SUPPLY CHARACTERISTICS						
VDD Supply Range Supporting EEPROM Programming	VDD		2.6		3.6	V
AVDD Supply Range Supporting EEPROM Programming	AVDD		10.8		18	V
VDD Supply Range for Wide-supply Operation (not supporting EEPROM programming)	VDD		2.25		3.6	V
AVDD Supply Range for Wide-supply Operation (not supporting EEPROM programming)	AVDD	2.6V < VDD < 3.6V	4.5		18	V
		2.25V < VDD < 2.6V	4.5		13	V
VDD Supply Current	IDD	(Note 7)			65	µA
AVDD Supply Current	I _{AVDD}	(Note 8)			38	µA
DC CHARACTERISTICS						
SET Voltage Resolution	SET _{VR}		7	7	7	Bits
SET Differential Nonlinearity	SET _{DN}	Monotonic Over-temperature			±1	LSB
SET Zero-scale Error	SET _{ZSE}				±3	LSB
SET Full-scale Error	SET _{FSE}				±8	LSB
SET Current (R _{SET} = 24.9kΩ and AV _{DD} = 10V)	ISET	Through R _{SET} (Note 11)		20		µA
SET External Resistance	SET _{ER}	To GND, AV _{DD} = 18V	5		200	kΩ
		To GND, AV _{DD} = 4.5V	2.25		45	kΩ
		To GND, AV _{DD} = 15V, V _{DD} = 3V V _{OUT} > 2.5V (Note 12)	1.0		200	kΩ
AV _{DD} to SET Voltage Attenuation	AVDD to SET	(Note 9)		1:20		V/V
OUT Settling Time	OUT _{ST}	To ±0.5 LSB Error Band (Note 9)		8		µs
OUT Voltage Range	V _{OUT}		V_{SET} + 0.5V		13	V
SET Voltage Drift	SET _{VD}	25°C < T _A < 55°C (Note 9)		<10		mV

Electrical Specifications Test Conditions: $V_{DD} = 3.3V$, $AV_{DD} = 18V$, $R_{SET} = 5k\Omega$, $R1 = 10k\Omega$, $R2 = 10k\Omega$; (See [Figure 2](#)) Unless otherwise specified. Typical values are at $T_A = +25^\circ C$. **Boldface limits apply across the operating temperature range, $0^\circ C$ to $+85^\circ C$.** (Continued)

PARAMETER	SYMBOL	TEST CONDITIONS	MIN (Note 6)	TYP	MAX (Note 6)	UNITS
SDA, SCL Input Logic High	I^2CV_{IH}		$0.7 \cdot V_{DD}$			V
SDA, SCL Input Logic Low	I^2CV_{IL}				0.55	V
SDA, SCL Hysteresis		(Note 9)		260		mV
SDA Output Logic High	VOH_S		$V_{DD} - 0.4$			V
SDA Output Logic Low	VOL_S	at 3mA			0.4	V
\overline{WP} Input Logic High	V_{IH}		$0.7 \cdot V_{DD}$			V
\overline{WP} Input Logic Low	V_{IL}				$0.3 \cdot V_{DD}$	V
\overline{WP} Hysteresis		(Note 9)		$0.14V_{DD}$		V
\overline{WP} Input Current	IL_{WPN}		0.20		35	μA
I^2C Timing						
SCL Clock Frequency	f_{SCL}		0		400	kHz
I^2C Clock High Time	t_{SCH}		0.6			μs
I^2C Clock Low Time	t_{SCL}		1.3			μs
I^2C Spike Rejection Filter Pulse Width	t_{DSP}		0		50	ns
I^2C Data Set Up Time	t_{SDS}		100			ns
I^2C Data Hold Time	t_{SDH}		900			ns
I^2C SDA, SCL Input Rise Time	t_{ICR}	Dependent on Load (Note 10)		$20 + 0.1 \cdot C_b$	1000	ns
I^2C SDA, SCL Input Fall Time	t_{ICF}	(Note 10)		$20 + 0.1 \cdot C_b$	300	ns
I^2C Bus Free Time Between Stop and Start	t_{BUF}		200			μs
I^2C Repeated Start Condition Set-up	t_{STS}		0.6			μs
I^2C Repeated Start Condition Hold	t_{STH}		0.6			μs
I^2C Stop Condition Set-up	t_{SPS}		0.6			μs
I^2C Bus Capacitive Load	C_b				400	pF
SDA Pin Capacitance	C_{SDA}				10	pF
SCL Pin Capacitance	C_S				10	pF
EEPROM Write Cycle Time	t_W				100	ms

NOTES:

- Compliance to datasheet limits is assured by one or more methods: production test, characterization and/or design.
- I_{DD} current may increase to 2mA for 45ms or less during each EEPROM programming operation.
- I_{AVDD} current may increase to 1mA for 30ms or less during each EEPROM programming operation.
- Simulated and Determined via Design and NOT Directly Tested.
- Simulated and Designed According to I^2C Specifications.
- A typical Current of 20 μA is Calculated using $AV_{DD} = 10V$ and $R_{SET} = 24.9k\Omega$. Reference "R_{SET} Resistor" in [Figure 3](#).
- Minimum value of R_{SET} resistor guaranteed when: $AV_{DD} = 15V$, $V_{DD} = 3.0V$ and when voltage on the VOUT pin is greater than 2.5V. Reference [Equation 2 on page 5](#) with Setting = 128.

Application Information

This device provides the ability to reduce the flicker of an LCD panel by adjustment of the V_{COM} voltage during production test and alignment. A 128-step resolution is provided under digital control, which adjusts the sink current of the output. The output is connected to an external voltage divider, so that the device will have the capability to reduce the voltage on the output by increasing the output sink current.

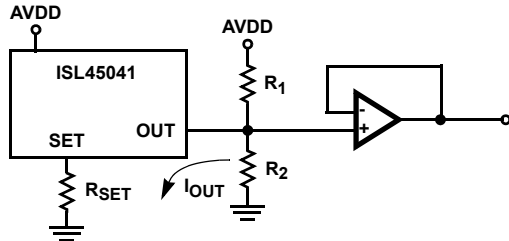

FIGURE 2. OUTPUT CONNECTION CIRCUIT EXAMPLE

The adjustment of the output is provided by the 2-wire I²C serial interface.

Expected Output Voltage

The ISL45041 provides an output sink current, which lowers the voltage on the external voltage divider (V_{COM} output voltage). Equations 1 and 2 can be used to calculate the output current (I_{OUT}) and output voltage (V_{OUT}) values. The setting is the register value +1 with a value between 1 and 128.

$$I_{OUT} = \frac{\text{Setting}}{128} \times \frac{AV_{DD}}{20(R_{SET})} \quad (\text{EQ. 1})$$

$$V_{OUT} = \left(\frac{R_2}{R_1 + R_2} \right) AV_{DD} \left(1 - \frac{\text{Setting}}{128} \times \frac{R_1}{20(R_{SET})} \right) \quad (\text{EQ. 2})$$

Table 1 gives the calculated value of V_{OUT} using the resistor values of: $R_{SET} = 24.9\text{k}\Omega$, $R_1 = 200\text{k}\Omega$, $R_2 = 243\text{k}\Omega$ and $AV_{DD} = 10\text{V}$.

TABLE 1.

SETTING VALUE	V _{OUT} (V)
1	5.468
10	5.313
20	5.141
30	4.969
40	4.797
50	4.625
60	4.453
70	4.281
80	4.109
90	3.936
100	3.764
110	3.592
128	3.282

R_{SET} Resistor

The external R_{SET} resistor sets the full-scale sink current, I_{SET} maximum, that determines the lowest voltage of the external voltage divider R_1 and R_2 (Figure 2). The voltage difference between the OUT pin and SET pin (Figure 3), which are also the drain and source of the output transistor, must be greater than 1.75V. This will keep the output transistor in its saturation region to maintain linear operation over the full range of register values. Expected current settings and 7-bit accuracy occurs when the output MOS transistor is operating in the saturation region. Figure 3 shows the internal connection for the output MOS transistor. The value of the AV_{DD} supply sets the voltage at the source of the output transistor. This voltage is equal to $(\text{Setting}/128) \times (AV_{DD}/20)$. The I_{SET} current is therefore equal to $(\text{Setting}/128) \times (AV_{DD}/20 \times R_{SET})$. The drain voltage is calculated using Equation 2. The values of R_1 and R_2 (Equation 2) should be determined using I_{OUT} maximum (setting equal to 128) so the minimum value of V_{OUT} is greater than $1.75\text{V} + AV_{DD}/20$.

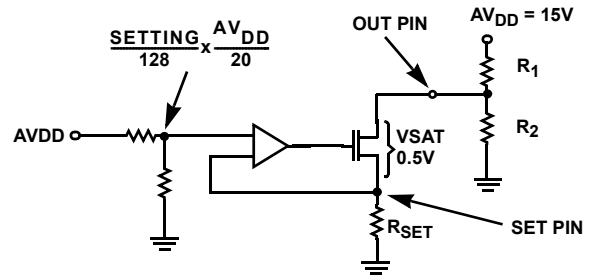

FIGURE 3. OUTPUT CONNECTION CIRCUIT EXAMPLE

Ramp-Up of the V_{DD} Power Supply

The ramp-up from 10% V_{DD} to 90% V_{DD} level must be achieved in 10ms or less to ensure that the EEPROM and power-on-reset circuits are synchronized and the correct value is read from the EEPROM Memory.

Power Supply Sequence

The recommended power supply sequencing is shown in Figure 3. When applying power, V_{DD} should be applied before or at the same time as AV_{DD} . The minimum time for t_{VS} is 0 μ s. When removing power, the sequence of V_{DD} and AV_{DD} is not important.

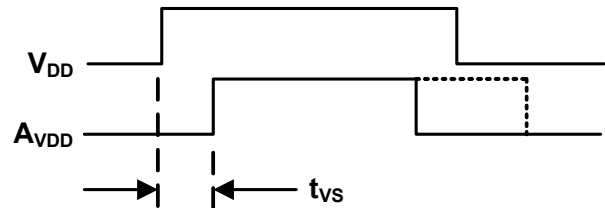
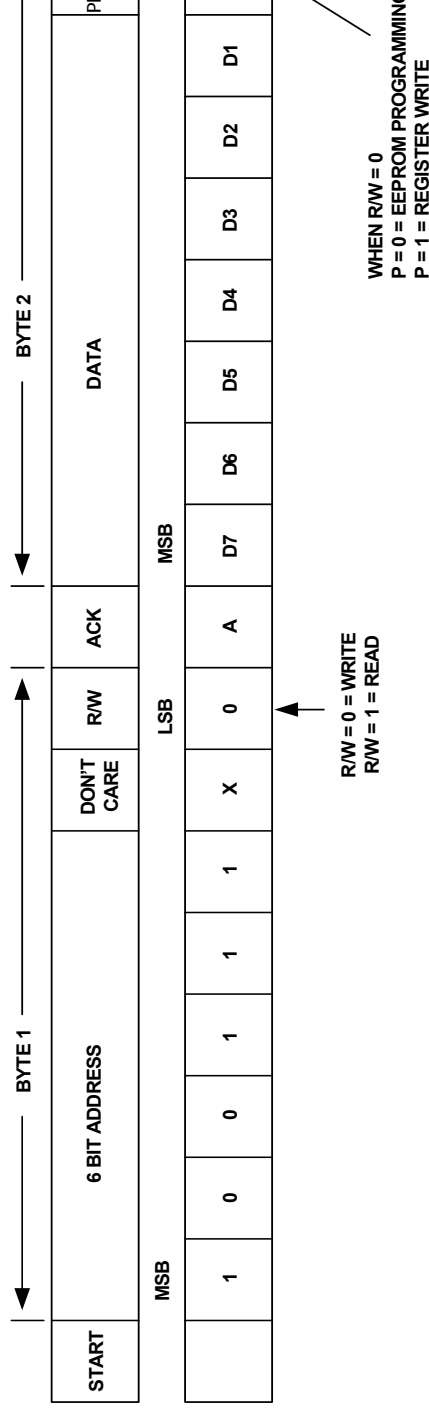

FIGURE 3. POWER SUPPLY SEQUENCE

Do not remove V_{DD} or AV_{DD} within 100ms of the start of the EEPROM programming cycle. Removing power before the EEPROM programming cycle is completed may result in corrupted data in the EEPROM.

I²C Bus Format

ISL45041 I²C WRITE FORMAT



ISL45041 I²C READ FORMAT

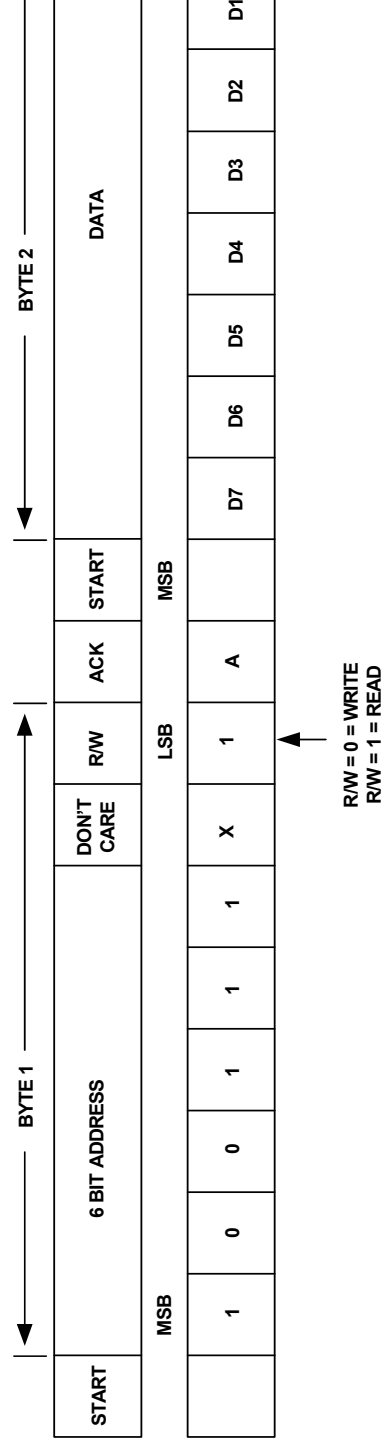

FIGURE 4. ISL45041 I²C READ AND WRITE FORMAT

I²C Addressing

The ISL45041 will respond identically to either of two I²C address: 1001110x and 1001111x. 100111x is the preferred address. To prevent bus conflicts, ensure that there are no other devices on the I²C bus with either of the above addresses.

Revision History

The revision history provided is for informational purposes only and is believed to be accurate, but not warranted. Please go to the web to make sure that you have the latest revision.

DATE	REVISION	CHANGE
April 22, 2016	FN6189.6	Removed AN1244 from related literature section.
October 30, 2014	FN6189.5	Updated datasheet to Intersil's new standards. Added related Literature on page 1. Moved Block Diagram to page 1. Moved the Pin Configurations and Ordering Information to page 2. Added Pad to "Pin Descriptions" on page 2. In Table 1 on page 5, updated typo in first row (VOUT value) from "5.486" to "5.468" and added (V) units to header. Added revision history and About Intersil sections.

About Intersil

Intersil Corporation is a leading provider of innovative power management and precision analog solutions. The company's products address some of the largest markets within the industrial and infrastructure, mobile computing and high-end consumer markets.

For the most updated datasheet, application notes, related documentation and related parts, please see the respective product information page found at www.intersil.com.

You may report errors or suggestions for improving this datasheet by visiting www.intersil.com/ask.

Reliability reports are also available from our website at www.intersil.com/support.

© Copyright Intersil Americas LLC 2005-2016. All Rights Reserved.
All trademarks and registered trademarks are the property of their respective owners.

For additional products, see www.intersil.com/en/products.html

Intersil products are manufactured, assembled and tested utilizing ISO9001 quality systems as noted in the quality certifications found at www.intersil.com/en/support/qualandreliability.html

Intersil products are sold by description only. Intersil may modify the circuit design and/or specifications of products at any time without notice, provided that such modification does not, in Intersil's sole judgment, affect the form, fit or function of the product. Accordingly, the reader is cautioned to verify that datasheets are current before placing orders. Information furnished by Intersil is believed to be accurate and reliable. However, no responsibility is assumed by Intersil or its subsidiaries for its use; nor for any infringements of patents or other rights of third parties which may result from its use. No license is granted by implication or otherwise under any patent or patent rights of Intersil or its subsidiaries.

For information regarding Intersil Corporation and its products, see www.intersil.com

Looking for pricing, stock, or lifecycle information?

Click below to explore more details on WIN SOURCE:

-  [View ISL45041IRZ-T on WIN SOURCE](#)
-  [Renesas Electronics America](#) Information

Optimize Your Supply Chain with WIN SOURCE Solutions

-  Global Sourcing Solution
-  Obsolete Management
-  Cost Control Management
-  Shortage Management
-  Alternative Solution
-  Excess Inventory Management