



**THE DATASHEET OF  
ISL43111BZ**



## ISL43110, ISL43111

Low-Voltage, Single Supply, SPST, High Performance Analog Switches

FN6028  
Rev 4.00  
June 27, 2014

The Intersil ISL43110 and ISL43111 are precision, high performance analog switches that are fully specified for 3.3V, 5V, and 12V operation, and feature improved leakage, ICC and switching time specifications.

Designed to operate from a single +2.4V to +12V supply, the low supply current (1 $\mu$ A Max over-temperature and voltage ranges) and low leakage currents (1nA) make these switches ideal for battery powered applications.

Low  $r_{ON}$  and fast switching speeds over a wide operating supply range increase these devices usefulness in industrial equipment, portable instruments, and as input signal multiplexers for new generation, low supply voltage data converters. Some of the smallest packages are available alleviating board space limitations, and making Intersil's newest line of low-voltage switches an ideal solution.

The ISL43110 and ISL43111 are single-pole/single-throw (SPST) switches, with the ISL43110 being normally open (NO), and the ISL43111 being normally closed (NC).

[Table 1](#) summarizes the performance of this family. For similar performance  $\pm$ 5V supply versions, see the [ISL43112](#) and [ISL43113](#) data sheets.

**TABLE 1. FEATURES AT A GLANCE**

	ISL43110	ISL43111
Number of Switches	1	1
Configuration	NO	NC
3.3V $r_{ON}$	15 $\Omega$	15 $\Omega$
3.3V $t_{ON}$ / $t_{OFF}$	55ns/28ns	55ns/28ns
5V $r_{ON}$	11 $\Omega$	11 $\Omega$
5V $t_{ON}/t_{OFF}$	45ns/20ns	45ns/20ns
12V $r_{ON}$	7 $\Omega$	7 $\Omega$
12V $t_{ON}/t_{OFF}$	37ns/21ns	37ns/21ns
Packages	8 Ld SOIC, 5 Ld SOT-23	

## Related Literature

- Tech Brief [TB363](#) "Guidelines for Handling and Processing Moisture Sensitive Surface Mount Devices (SMDs)"

## Features

- Fully specified at 3.3V, 5V, and 12V supplies
- Available in SOT-23 packaging
- Single supply operation ..... +2.4V to +12V
- ON-Resistance ( $r_{ON}$  max) ..... 20 $\Omega$  ( $V+$  = 5V)  
..... 10 $\Omega$  ( $V+$  = 12V)
- $r_{ON}$  flatness ..... 1.5 $\Omega$
- Charge injection (max) ..... 10pC
- Low power consumption ( $P_D$  max) ..... 5 $\mu$ W
- Low leakage current (max at +85 $^{\circ}$ C) .. 10nA (Off Leakage)  
..... 20nA (On Leakage)
- Fast switching action
  - $t_{ON}$  (max) ..... 80ns
  - $t_{OFF}$  (max) ..... 50ns
- Minimum 2kV ESD protection per method 3015.7
- TTL, CMOS compatible
- Pb-free (RoHS compliant)

## Applications

- Battery powered, handheld, and portable equipment
  - Cellular/mobile phones, pagers
  - Laptops, notebooks, palmtops, PDAs
- Communications systems
  - Radios
  - PBX, PABX
- Test equipment
  - Logic and spectrum analyzers
  - Portable meters, DVM, DMM
- Medical equipment
  - Ultrasound, MRI, CAT SCAN
  - Electrocardiograph, blood analyzer
- Heads-up displays
- Audio and video switching
- General purpose circuits
  - +3V/+5V DACs and ADCs
  - Sample and hold circuits
  - Digital filters
  - Operational amplifier gain switching networks
  - High frequency analog switching
  - High speed multiplexing
  - Integrator reset circuits

## Ordering Information

PART NUMBER (Notes 2, 3, )	PART MARKING	TEMP RANGE (°C)	PACKAGE (Pb-free)	PKG. DWG. #
ISL43110IBZ	ISL431 10IBZ	-40 to +85	8 Ld SOIC	M8.15
ISL43110IBZ-T (Note 1)	ISL431 10IBZ	-40 to +85	8 Ld SOIC	M8.15
ISL43110IHZ-T (Note 1)	110Z (Note 4)	-40 to +85	5 Ld SOT-23	P5.064
ISL43111IBZ	ISL431 11IBZ	-40 to +85	8 Ld SOIC	M8.15
ISL43111IBZ-T (Note 1)	ISL431 11IBZ	-40 to +85	8 Ld SOIC	M8.15
ISL43111IHZ-T (Note 1)	111Z (Note 4)	-40 to +85	5 Ld SOT-23	P5.064

**NOTES:**

1. Please refer to [TB347](#) for details on reel specifications.
2. These Intersil Pb-free plastic packaged products employ special Pb-free material sets, molding compounds/die attach materials, and 100% matte tin plate plus anneal (e3 termination finish, which is RoHS compliant and compatible with both SnPb and Pb-free soldering operations). Intersil Pb-free products are MSL classified at Pb-free peak reflow temperatures that meet or exceed the Pb-free requirements of IPC/JEDEC J STD-020.
3. For Moisture Sensitivity Level (MSL), please see product information page for [ISL43110](#), [ISL43111](#). For more information on MSL, please see tech brief [TB363](#)
4. The part marking is located on the bottom of the part.

## Pin Configurations (Note 5)

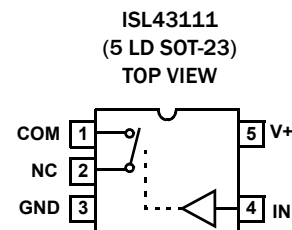
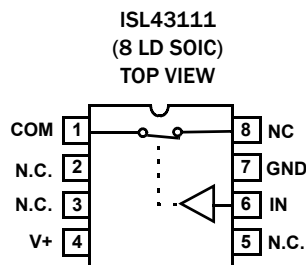
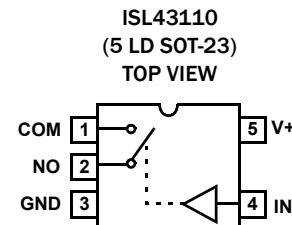
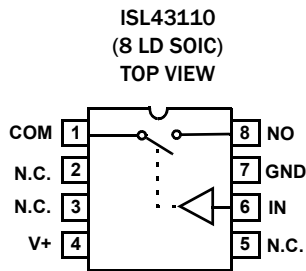

**NOTE:**

5. Switches Shown for Logic "0" Input.

## Pin Descriptions

PIN#	FUNCTION
V+	System Power Supply Input (+2.4V to +12V)
GND	Ground Connection
IN	Digital Control Input
COM	Analog Switch Common Pin
NO	Analog Switch Normally Open Pin
NC	Analog Switch Normally Closed Pin
N.C.	No Internal Connection

## Truth Table

LOGIC	ISL43110	ISL43111
0	OFF	ON
1	ON	OFF

NOTE: Logic "0" ≤ 0.8V. Logic "1" ≥ 2.4V.

## Absolute Maximum Ratings

V+ to GND	-0.3 to 15V
Input Voltages	
IN (Note 6)	-0.3 to ((V+) + 0.3V)
NO, NC (Note 6)	-0.3 to ((V+) + 0.3V)
Output Voltages	
COM (Note 6)	-0.3 to ((V+) + 0.3V)
Continuous Current (Any Terminal)	20mA
Peak Current NO, NC, or COM (Pulsed 1ms, 10% Duty Cycle, Max)	30mA
ESD Rating (Per MIL-STD-883 Method 3015)	>2kV

## Thermal Information

Thermal Resistance (Typical, Note 7)	$\theta_{JA}$ °C/W)
5 Ld SOT-23 Package	225
8 Ld SOIC Package	170
Maximum Junction Temperature (Plastic Package)	+150°C
Maximum Storage Temperature Range	-65°C to +150°C
Pb-Free Reflow Profile	see <a href="#">TB493</a>

## Operating Conditions

Temperature Range	-40°C to +85°C
-------------------	----------------

CAUTION: Do not operate at or near the maximum ratings listed for extended periods of time. Exposure to such conditions may adversely impact product reliability and result in failures not covered by warranty.

### NOTES:

6. Signals on NO, NC, COM, or IN exceeding V+ or GND are clamped by internal diodes. Limit forward diode current to maximum current ratings.
7.  $\theta_{JA}$  is measured with the component mounted on a low effective thermal conductivity test board in free air. See Tech Brief [TB379](#) for details.

**Electrical Specifications (5V Supply)** Test Conditions: V+ = +4.5V to +5.5V, GND = 0V,  $V_{INH}$  = 2.4V,  $V_{INL}$  = 0.8V (Note 9), Unless Otherwise Specified.

PARAMETER	TEST CONDITIONS	TEMP (°C)	MIN (Notes 8, 10)	TYP	MAX (Notes 8, 10)	UNIT S
<b>ANALOG SWITCH CHARACTERISTICS</b>						
Analog Signal Range, $V_{ANALOG}$		Full	0		V+	V
ON-Resistance, $r_{ON}$	V+ = 4.5V, $I_{COM}$ = 1.0mA, $V_{COM}$ = 3.5V, (Figure 4)	25		11	20	$\Omega$
		Full		15	25	$\Omega$
$r_{ON}$ Flatness, $R_{FLAT(ON)}$	$I_{COM}$ = 1.0mA, $V_{COM}$ = 1V, 2V, 3V	25		1.5	3	$\Omega$
		Full		2.5	5	$\Omega$
NO or NC OFF Leakage Current, $I_{NO(OFF)}$ or $I_{NC(OFF)}$	V+ = 5.5V, $V_{COM}$ = 1V, 4.5V, $V_{NO}$ or $V_{NC}$ = 4.5V, 1V, (Note 11)	25	-1	0.01	1	nA
		Full	-10		10	nA
COM OFF Leakage Current, $I_{COM(OFF)}$	V+ = 5.5V, $V_{COM}$ = 4.5V, 1V, $V_{NO}$ or $V_{NC}$ = 1V, 4.5V, (Note 11)	25	-1	0.01	1	nA
		Full	-10		10	nA
COM ON Leakage Current, $I_{COM(ON)}$	V+ = 5.5V, $V_{COM}$ = 1V, 4.5V, or $V_{NO}$ or $V_{NC}$ = 1V, 4.5V, (Note 11)	25	-1	0.01	1	nA
		Full	-20		20	nA
<b>DIGITAL INPUT CHARACTERISTICS</b>						
Input Voltage High, $V_{INH}$		Full	2.4			V
Input Voltage Low, $V_{INL}$		Full			0.8	V
Input Current, $I_{INH}$ , $I_{INL}$	V+ = 5.5V, $V_{IN}$ = 0V or V+	Full	-1		1	$\mu$ A
<b>DYNAMIC CHARACTERISTICS</b>						
Turn-ON Time, $t_{ON}$	$V_{NO}$ or $V_{NC}$ = 3V, $R_L$ = 300 $\Omega$ , $C_L$ = 35pF, $V_{IN}$ = 0 to 3V, (Figure 1)	25		45	80	ns
		Full		50	120	ns
Turn-OFF Time, $t_{OFF}$	$V_{NO}$ or $V_{NC}$ = 3V, $R_L$ = 300 $\Omega$ , $C_L$ = 35pF, $V_{IN}$ = 0 to 3V, (Figure 1)	25		20	50	ns
		Full		28	75	ns
Charge Injection, Q	$C_L$ = 1.0nF, $V_G$ = 0V, $R_G$ = 0 $\Omega$ , (Figure 2)	25		2	10	pC
OFF-Isolation	$R_L$ = 50 $\Omega$ , $C_L$ = 15pF, f = 100kHz, (Figure 3)	25		>90		dB

**Electrical Specifications (5V Supply)** Test Conditions:  $V_+ = +4.5V$  to  $+5.5V$ ,  $GND = 0V$ ,  $V_{INH} = 2.4V$ ,  $V_{INL} = 0.8V$  (Note 9), Unless Otherwise Specified. (Continued)

PARAMETER	TEST CONDITIONS	TEMP (°C)	MIN (Notes 8, 10)	TYP	MAX (Notes 8, 10)	UNIT S
Power Supply Rejection Ratio	$R_L = 50\Omega$ , $C_L = 5pF$ , $f = 1MHz$	25		60		dB
NO or NC OFF Capacitance, $C_{OFF}$	$f = 1MHz$ , $V_{NO}$ or $V_{NC} = V_{COM} = 0V$ , (Figure 5)	25		15		pF
COM OFF Capacitance, $C_{COM(OFF)}$	$f = 1MHz$ , $V_{NO}$ or $V_{NC} = V_{COM} = 0V$ , (Figure 5)	25		15		pF
COM ON Capacitance, $C_{COM(ON)}$	$f = 1MHz$ , $V_{NO}$ or $V_{NC} = V_{COM} = 0V$ , (Figure 5)	25		40		pF
<b>POWER SUPPLY CHARACTERISTICS</b>						
Positive Supply Current, $I_+$	$V_+ = 5.5V$ , $V_{IN} = 0V$ or $V_+$ , Switch On or Off	Full	-1		1	$\mu A$

**Electrical Specifications (12V Supply)** Test Conditions:  $V_+ = +10.8V$  to  $+13V$ ,  $GND = 0V$ ,  $V_{INH} = 4V$ ,  $V_{INL} = 0.8V$  (Note 9), Unless Otherwise Specified.

PARAMETER	TEST CONDITIONS	TEMP (°C)	MIN (Notes 8, 10)	TYP	MAX (Notes 8, 10)	UNITS
<b>ANALOG SWITCH CHARACTERISTICS</b>						
Analog Signal Range, $V_{ANALOG}$		Full	0		$V_+$	V
ON-Resistance, $r_{ON}$	$V_+ = 10.8V$ , $I_{COM} = 1.0mA$ , $V_{COM} = 10V$	25		7	10	$\Omega$
		Full		8	15	$\Omega$
$r_{ON}$ Flatness, $R_{FLAT(ON)}$	$I_{COM} = 1.0mA$ , $V_{COM} = 3V, 6V, 9V$	25		1	3	$\Omega$
		Full		1.5	5	$\Omega$
NO or NC OFF Leakage Current, $I_{NO(OFF)}$ or $I_{NC(OFF)}$	$V_+ = 13V$ , $V_{COM} = 1V, 10V$ , $V_{NO}$ or $V_{NC} = 10V, 1V$ , (Note 11)	25	-1		1	nA
		Full	-10		10	nA
COM OFF Leakage Current, $I_{COM(OFF)}$	$V_+ = 13V$ , $V_{COM} = 10V, 1V$ , $V_{NO}$ or $V_{NC} = 1V, 10V$ , (Note 11)	25	-1		1	nA
		Full	-10		10	nA
COM ON Leakage Current, $I_{COM(ON)}$	$V_+ = 13V$ , $V_{COM} = 1V, 10V$ , or $V_{NO}$ or $V_{NC} = 1V, 10V$ , (Note 11)	25	-1		1	nA
		Full	-20		20	nA
<b>DIGITAL INPUT CHARACTERISTICS</b>						
Input Voltage High, $V_{INH}$		Full	4			V
Input Voltage Low, $V_{INL}$		Full			0.8	V
Input Current, $I_{INH}$ , $I_{INL}$	$V_+ = 13V$ , $V_{IN} = 0V$ or $V_+$	Full	-1		1	$\mu A$
<b>DYNAMIC CHARACTERISTICS</b>						
Turn-ON Time, $t_{ON}$	$V_{NO}$ or $V_{NC} = 10V$ , $R_L = 300\Omega$ , $C_L = 35pF$	25		37	80	ns
		Full		42	120	ns
Turn-OFF Time, $t_{OFF}$	$V_{NO}$ or $V_{NC} = 10V$ , $R_L = 300\Omega$ , $C_L = 35pF$	25		21	50	ns
		Full		26	75	ns
Charge Injection, $Q$	$C_L = 1.0nF$ , $V_G = 0V$ , $R_G = 0\Omega$	25		8	20	pC
OFF Isolation	$R_L = 50\Omega$ , $C_L = 15pF$ , $f = 100kHz$	25		>90		dB
Power Supply Rejection Ratio	$R_L = 50\Omega$ , $C_L = 5pF$ , $f = 1MHz$	25		67		dB
NO or NC OFF Capacitance, $C_{OFF}$	$f = 1MHz$ , $V_{NO}$ or $V_{NC} = V_{COM} = 0V$	25		15		pF
COM OFF Capacitance, $C_{COM(OFF)}$	$f = 1MHz$ , $V_{NO}$ or $V_{NC} = V_{COM} = 0V$	25		15		pF
COM ON Capacitance, $C_{COM(ON)}$	$f = 1MHz$ , $V_{NO}$ or $V_{NC} = V_{COM} = 0V$	25		40		pF
<b>POWER SUPPLY CHARACTERISTICS</b>						
Positive Supply Current, $I_+$	$V_+ = 13V$ , $V_{IN} = 0V$ or $V_+$ , Switch On or Off	Full	-1		1	$\mu A$

**Electrical Specifications (3.3V Supply)** Test Conditions:  $V+ = +3.0V$  to  $+3.6V$ ,  $GND = 0V$ ,  $V_{INH} = 2.4V$ ,  $V_{INL} = 0.8V$  (Note 9), Unless Otherwise Specified.

PARAMETER	TEST CONDITIONS	TEMP (°C)	MIN (Notes 8, 10)	TYP	MAX (Notes 8, 10)	UNITS
<b>ANALOG SWITCH CHARACTERISTICS</b>						
Analog Signal Range, $V_{ANALOG}$		Full	0		V+	V
ON-Resistance, $r_{ON}$	$V+ = 3V$ , $I_{COM} = 1.0mA$ , $V_{COM} = 1.5V$	25		15	30	$\Omega$
		Full		18	40	$\Omega$
$r_{ON}$ Flatness, $R_{FLAT(ON)}$	$I_{COM} = 1.0mA$ , $V_{COM} = 0.5V, 1V, 1.5V$	25		3	5.5	$\Omega$
		Full		4	7	$\Omega$
NO or NC OFF Leakage Current, $I_{NO(OFF)}$ or $I_{NC(OFF)}$	$V+ = 3.6V$ , $V_{COM} = 1V, 3V$ , $V_{NO}$ or $V_{NC} = 3V, 1V$ , (Note 11)	25	-1		1	nA
		Full	-10		10	nA
COM OFF Leakage Current, $I_{COM(OFF)}$	$V+ = 3.6V$ , $V_{COM} = 3V, 1V$ , $V_{NO}$ or $V_{NC} = 1V, 3V$ , (Note 11)	25	-1		1	nA
		Full	-10		10	nA
COM ON Leakage Current, $I_{COM(ON)}$	$V+ = 3.6V$ , $V_{COM} = 1V, 3V$ , or $V_{NO}$ or $V_{NC} = 1V, 3V$ , or floating, (Note 11)	25	-1		1	nA
		Full	-20		20	nA
<b>DIGITAL INPUT CHARACTERISTICS</b>						
Input Voltage High, $V_{INH}$		Full	2.4			V
Input Voltage Low, $V_{INL}$		Full			0.8	V
Input Current, $I_{INH}$ , $I_{INL}$	$V+ = 3.6V$ , $V_{IN} = 0V$ or $V+$	Full	-1		1	$\mu A$
<b>DYNAMIC CHARACTERISTICS</b>						
Turn-ON Time, $t_{ON}$	$V_{NO}$ or $V_{NC} = 1.5V$ , $R_L = 300\Omega$ , $C_L = 35pF$ , $V_{IN} = 0$ to $3V$	25		55	100	ns
		Full		70	150	ns
Turn-OFF Time, $t_{OFF}$	$V_{NO}$ or $V_{NC} = 1.5V$ , $R_L = 300\Omega$ , $C_L = 35pF$ , $V_{IN} = 0$ to $3V$	25		28	60	ns
		Full		35	85	ns
Charge Injection, Q	$C_L = 1.0nF$ , $V_G = 0V$ , $R_G = 0\Omega$	25		2	10	pC
OFF Isolation	$R_L = 50\Omega$ , $C_L = 15pF$ , $f = 100kHz$	25		>90		dB
Power Supply Rejection Ratio	$R_L = 50\Omega$ , $C_L = 5pF$ , $f = 1MHz$	25		58		dB
NO or NC OFF Capacitance, $C_{OFF}$	$f = 1MHz$ , $V_{NO}$ or $V_{NC} = V_{COM} = 0V$	25		15		pF
COM OFF Capacitance, $C_{COM(OFF)}$	$f = 1MHz$ , $V_{NO}$ or $V_{NC} = V_{COM} = 0V$	25		15		pF
COM ON Capacitance, $C_{COM(ON)}$	$f = 1MHz$ , $V_{NO}$ or $V_{NC} = V_{COM} = 0V$	25		40		pF
<b>POWER SUPPLY CHARACTERISTICS</b>						
Positive Supply Current, $I+$	$V+ = 3.6V$ , $V_{IN} = 0V$ or $V+$ , Switch On or Off	Full	-1		1	$\mu A$

## NOTES:

8. Parameters with MIN and/or MAX limits are 100% tested at  $+25^\circ C$ , unless otherwise specified. Temperature limits established by characterization and are not production tested.
9.  $V_{IN}$  = input voltage to perform proper function.
10. The algebraic convention, whereby the most negative value is a minimum and the most positive a maximum, is used in this data sheet.
11. Leakage parameter is 100% tested at high temp, and guaranteed by correlation at  $+25^\circ C$ .

## Test Circuits and Waveforms

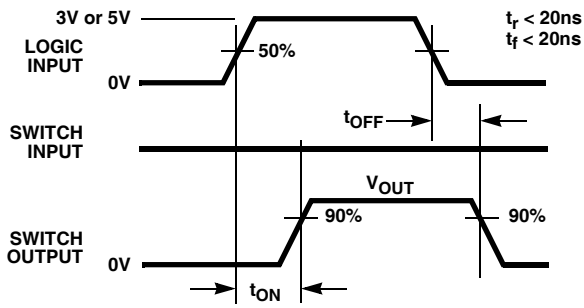

Logic input waveform is inverted for switches that have the opposite logic sense.

FIGURE 1A. MEASUREMENT POINTS

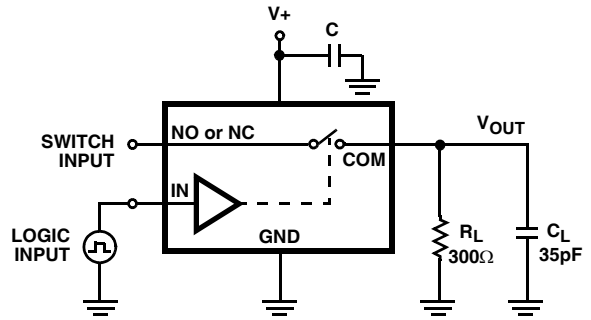

$C_L$  includes fixture and stray capacitance.  

$$V_{OUT} = V_{(NO\ or\ NC)} \frac{R_L}{R_L + r_{ON}}$$

FIGURE 1B. TEST CIRCUIT

FIGURE 1. SWITCHING TIMES

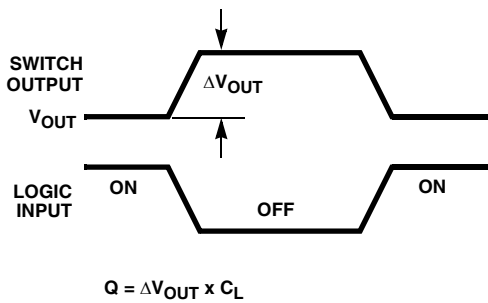

FIGURE 2A. MEASUREMENT POINTS

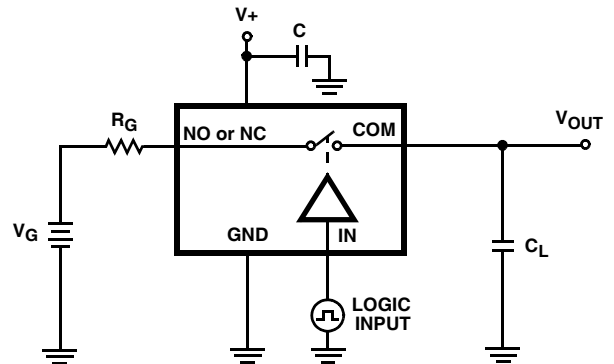

FIGURE 2B. TEST CIRCUIT

FIGURE 2. CHARGE INJECTION

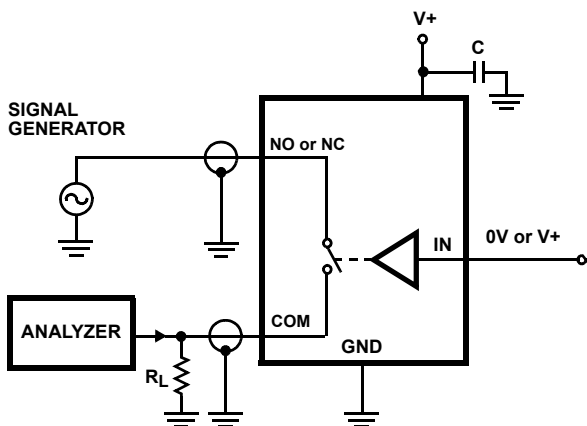

FIGURE 3. OFF ISOLATION TEST CIRCUIT

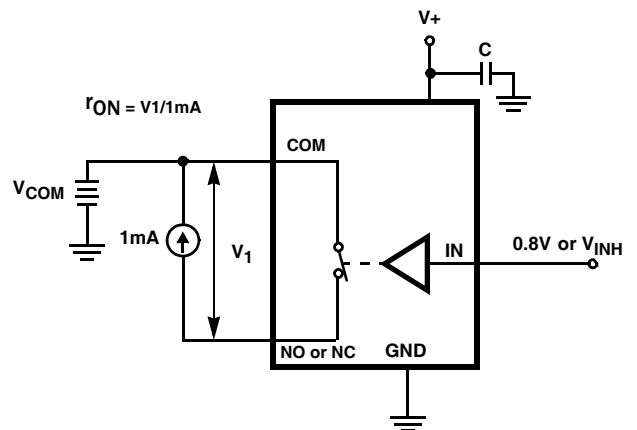

FIGURE 4.  $r_{ON}$  TEST CIRCUIT

## Test Circuits and Waveforms (Continued)

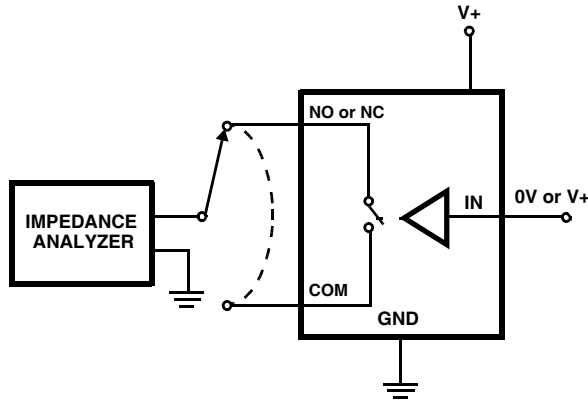

FIGURE 5. CAPACITANCE TEST CIRCUIT

## Detailed Description

The ISL43110 and ISL43111 analog switches offer precise switching capability from a single 2.4V to 12V supply with low ON-resistance and high speed operation. The devices are especially well suited to portable battery powered equipment thanks to the low operating supply voltage (2.4V), low power consumption (5 $\mu$ W), low leakage currents (1nA max), and the tiny SOT-23 packaging. High frequency applications also benefit from the wide bandwidth, and the very high off-isolation.

### Supply Sequencing And Overvoltage Protection

As with any CMOS device, proper power supply sequencing is required to protect the device from excessive input currents which might permanently damage the IC. All I/O pins contain, ESD protection diodes from the pin to V+ and to GND (see Figure 6). To prevent forward biasing these diodes, V+ must be applied before any input signals, and input signal voltages must remain between V+ and GND. If these conditions cannot be guaranteed, then one of the following two protection methods should be employed.

Logic inputs can easily be protected by adding a 1k $\Omega$  resistor in series with the input (see Figure 6). The resistor limits the input current below the threshold that produces permanent damage, and the sub-microamp input current produces an insignificant voltage drop during normal operation.

Adding a series resistor to the switch input defeats the purpose of using a low  $r_{ON}$  switch, so two small signal diodes can be added in series with the supply pins to provide overvoltage protection for all pins (see Figure 6). These additional diodes limit the analog signal from 1V below V+ to 1V above GND. The low leakage current performance is unaffected by this approach, but the switch resistance may increase, especially at low supply voltages.

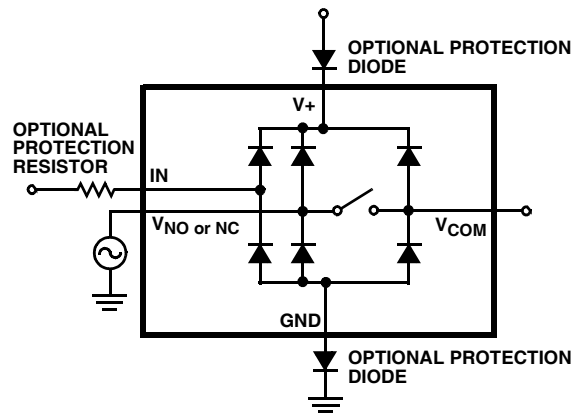

FIGURE 6. OVERVOLTAGE PROTECTION

### Power-Supply Considerations

The ISL4311X construction is typical of most CMOS analog switches, except that there are only two supply pins: V+ and GND. Unlike switches with a 13V maximum supply voltage, the ISL4311X 15V maximum supply voltage provides plenty of room for the 10% tolerance of 12V supplies, as-well-as room for overshoot and noise spikes.

The minimum recommended supply voltage is 2.4V. It is important to note that the input signal range, switching times, and ON-resistance degrade at lower supply voltages. Refer to the Electrical Specification on [page 3](#) and "[Typical Performance Curves](#)" on [page 8](#) for details.

V+ and GND power the internal CMOS switches and set their analog voltage limits. These supplies also power the internal logic and level shifters. The level shifters convert the input logic levels to switched V+ and GND signals to drive the analog switch gate terminals.

This family of switches cannot be operated with bipolar supplies, because the input switching point becomes negative in this configuration. For a  $\pm$ 5V single SPST switch, see the [ISL43112](#) and [ISL43113](#) data sheet.

### Logic-Level Thresholds

This switch family is TTL compatible (0.8V and 2.4V) over a supply range of 3V to 11V, and the full temperature range (see Figure 10). At 12V the low temperature  $V_{IH}$  level is about 2.5V. This is still below the TTL guaranteed high output minimum level of 2.8V, but noise margin is reduced. For best results with a 12V supply, use a logic family that provides a  $V_{OH}$  greater than 3V.

The digital input stages draw supply current whenever the digital input voltage is not at one of the supply rails. Driving the digital input signals from GND to  $V+$  with a fast transition time minimizes power dissipation.

### High-Frequency Performance

In  $50\Omega$  systems, signal response is reasonably flat to 20MHz, with a -3dB bandwidth exceeding 200MHz (see Figure 15). Figure 15 also illustrates that the frequency response is very consistent over a wide  $V+$  range, and for varying analog signal levels.

An OFF switch acts like a capacitor and passes higher frequencies with less attenuation, resulting in signal feedthrough from a switch's input to its output. Off-isolation is the resistance to this feedthrough. Figure 16 details the high

Off-isolation provided by this family. At 10MHz, off-isolation is about 50dB in  $50\Omega$  systems, decreasing approximately 20dB per decade as frequency increases. Higher load impedances decrease Off-isolation due to the voltage divider action of the switch OFF impedance and the load impedance.

### Leakage Considerations

Reverse ESD protection diodes are internally connected between each analog-signal pin and both  $V+$  and GND. One of these diodes conducts if any analog signal exceeds  $V+$  or GND.

Virtually all the analog leakage current comes from the ESD diodes to  $V+$  or GND. Although the ESD diodes on a given signal pin are identical and therefore fairly well balanced, they are reverse biased differently. Each is biased by either  $V+$  or GND and the analog signal. This means their leakages will vary as the signal varies. The difference in the two diode leakages to the  $V+$  and GND pins constitutes the analog-signal-path leakage current. All analog leakage current flows between each pin and one of the supply terminals, not to the other switch terminal. This is why both sides of a given switch can show leakage currents of the same or opposite polarity. There is no connection between the analog-signal paths and  $V+$  or GND.

## Typical Performance Curves

$T_A = +25^\circ\text{C}$ , Unless Otherwise Specified

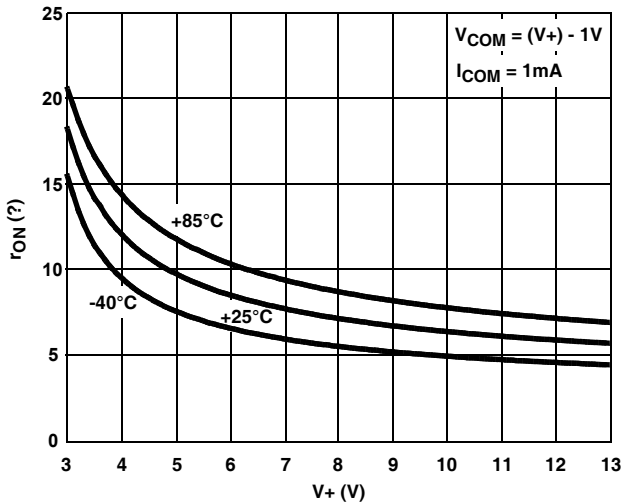

FIGURE 7. ON-RESISTANCE vs SUPPLY VOLTAGE

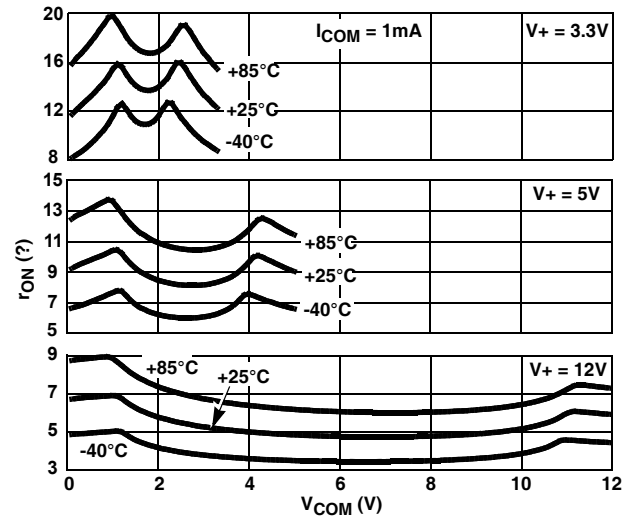

FIGURE 8. ON-RESISTANCE vs SWITCH VOLTAGE

**Typical Performance Curves**  $T_A = +25^\circ\text{C}$ , Unless Otherwise Specified (Continued)

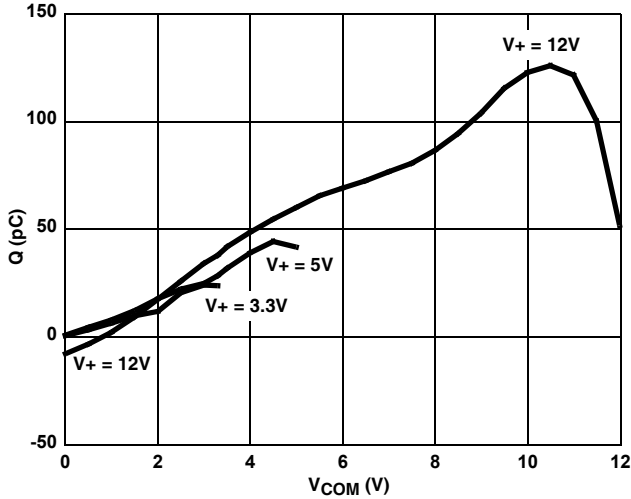

FIGURE 9. CHARGE INJECTION vs SWITCH VOLTAGE

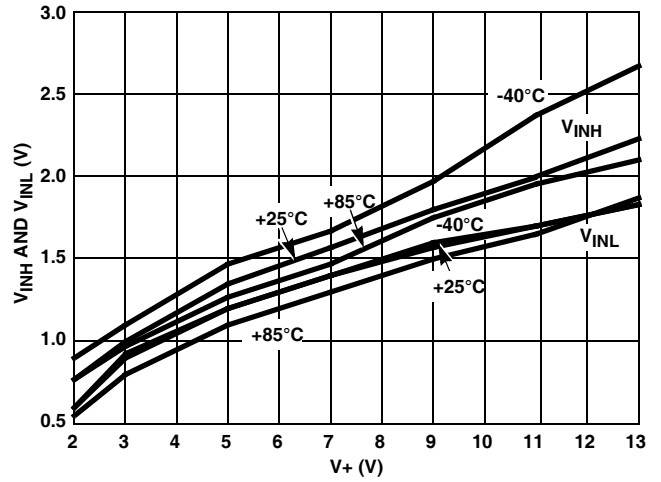

FIGURE 10. DIGITAL SWITCHING POINT vs SUPPLY VOLTAGE

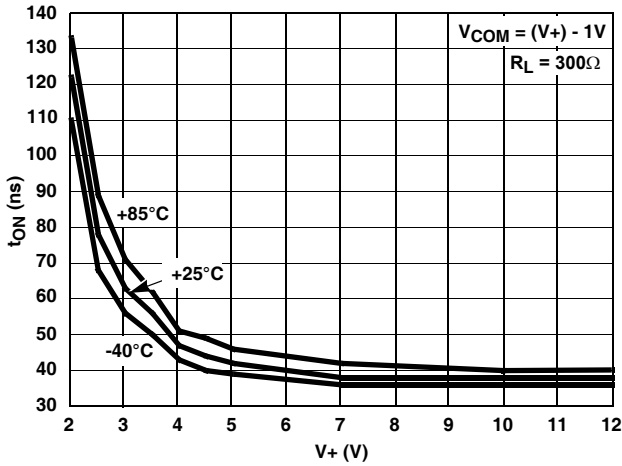

FIGURE 11. TURN - ON TIME vs SUPPLY VOLTAGE

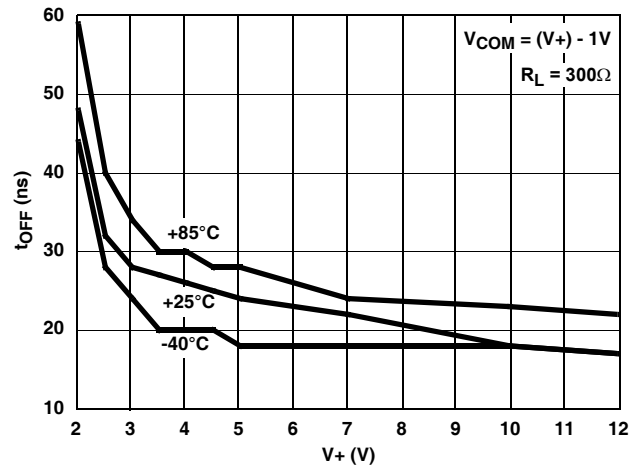

FIGURE 12. TURN - OFF TIME vs SUPPLY VOLTAGE

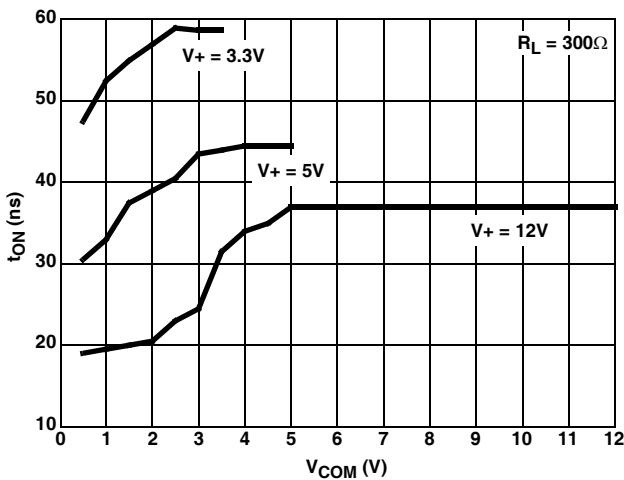

FIGURE 13. TURN - ON TIME vs SWITCH VOLTAGE

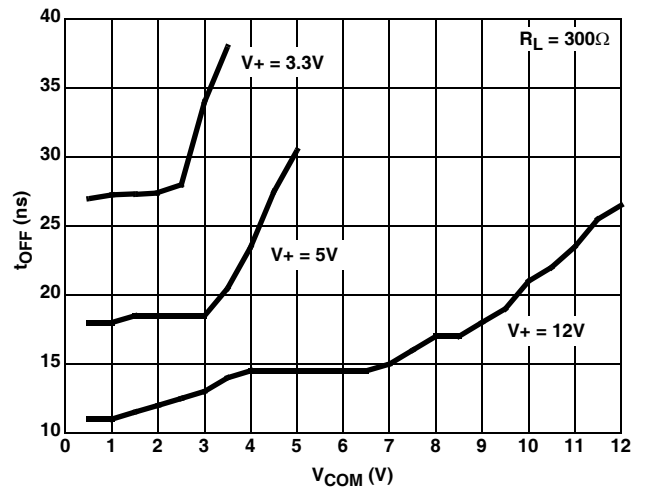

FIGURE 14. TURN - OFF TIME vs SWITCH VOLTAGE

**Typical Performance Curves**  $T_A = +25^\circ\text{C}$ , Unless Otherwise Specified (Continued)

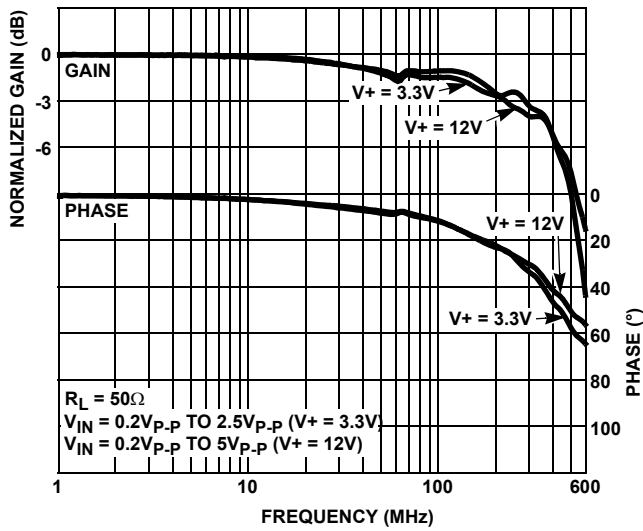

FIGURE 15. FREQUENCY RESPONSE

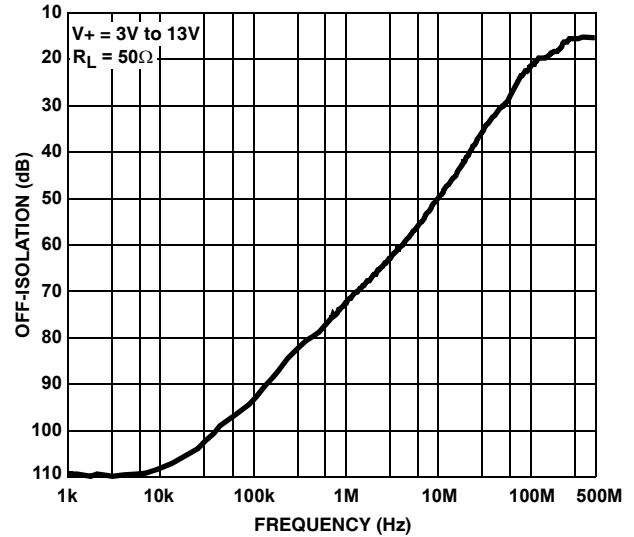

FIGURE 16. OFF-ISOLATION

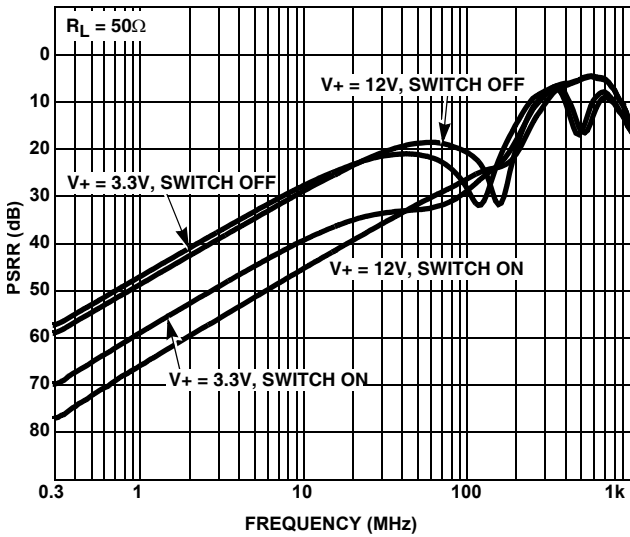

FIGURE 17. PSRR vs FREQUENCY

**Die Characteristics**

**SUBSTRATE POTENTIAL (POWERED UP):**

GND

**TRANSISTOR COUNT:**

ISL43110: 40

ISL43111: 40

**PROCESS:**

Si Gate CMOS

© Copyright Intersil Americas LLC 2002-2014. All Rights Reserved.

All trademarks and registered trademarks are the property of their respective owners.

For additional products, see [www.intersil.com/en/products.html](http://www.intersil.com/en/products.html)

Intersil products are manufactured, assembled and tested utilizing ISO9001 quality systems as noted in the quality certifications found at [www.intersil.com/en/support/qualandreliability.html](http://www.intersil.com/en/support/qualandreliability.html)

Intersil products are sold by description only. Intersil may modify the circuit design and/or specifications of products at any time without notice, provided that such modification does not, in Intersil's sole judgment, affect the form, fit or function of the product. Accordingly, the reader is cautioned to verify that datasheets are current before placing orders. Information furnished by Intersil is believed to be accurate and reliable. However, no responsibility is assumed by Intersil or its subsidiaries for its use; nor for any infringements of patents or other rights of third parties which may result from its use. No license is granted by implication or otherwise under any patent or patent rights of Intersil or its subsidiaries.

For information regarding Intersil Corporation and its products, see [www.intersil.com](http://www.intersil.com)

# Package Outline Drawing

## M8.15

8 LEAD NARROW BODY SMALL OUTLINE PLASTIC PACKAGE

Rev 4, 1/12

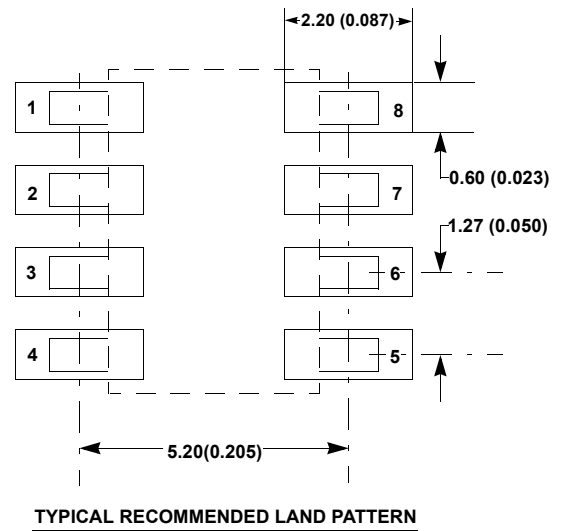
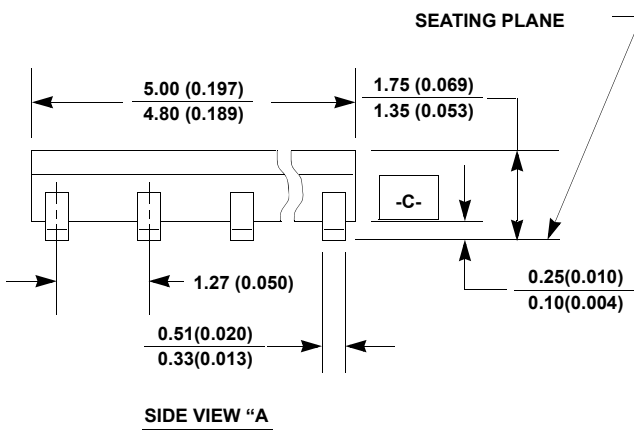
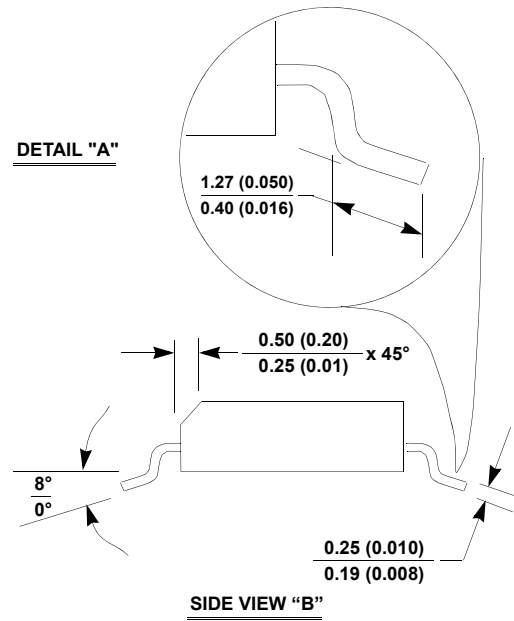
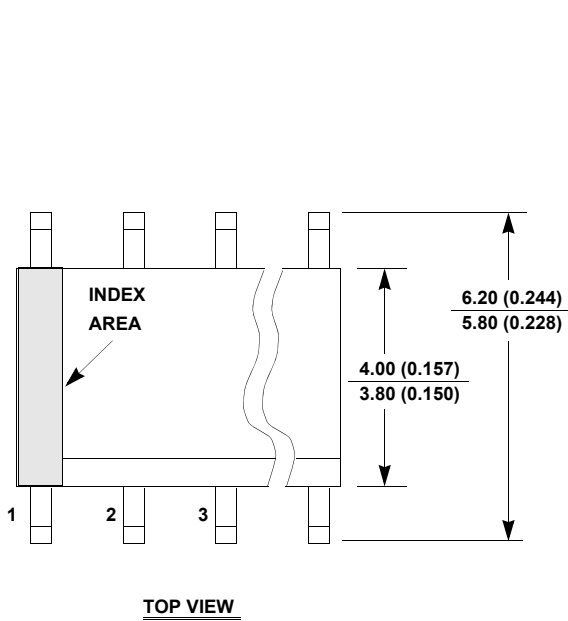

**NOTES:**

1. Dimensioning and tolerancing per ANSI Y14.5M-1994.
2. Package length does not include mold flash, protrusions or gate burrs. Mold flash, protrusion and gate burrs shall not exceed 0.15mm (0.006 inch) per side.
3. Package width does not include interlead flash or protrusions. Interlead flash and protrusions shall not exceed 0.25mm (0.010 inch) per side.
4. The chamfer on the body is optional. If it is not present, a visual index feature must be located within the crosshatched area.
5. Terminal numbers are shown for reference only.
6. The lead width as measured 0.36mm (0.014 inch) or greater above the seating plane, shall not exceed a maximum value of 0.61mm (0.024 inch).
7. Controlling dimension: MILLIMETER. Converted inch dimensions are not necessarily exact.
8. This outline conforms to JEDEC publication MS-012-AA ISSUE C.

# Package Outline Drawing

## P5.064

### 5 LEAD SMALL OUTLINE TRANSISTOR PLASTIC PACKAGE

Rev 3, 4/11

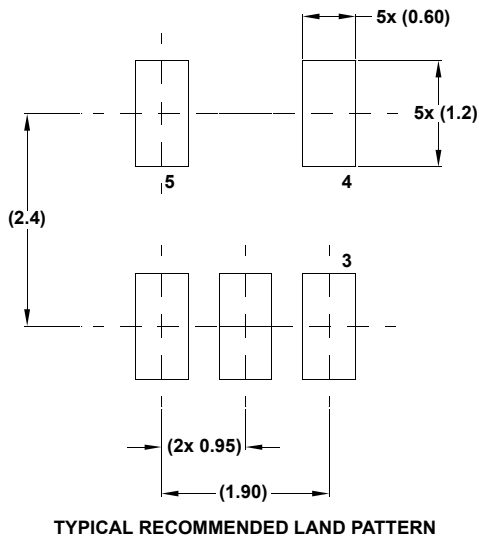
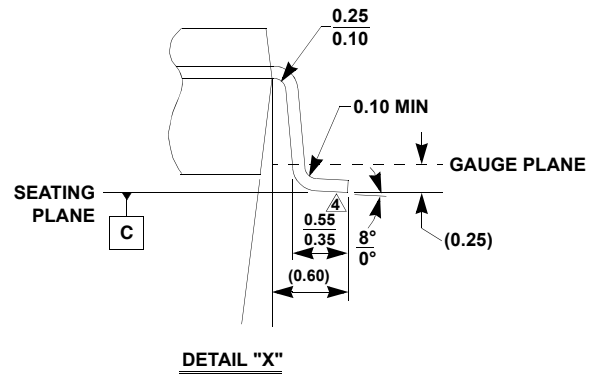
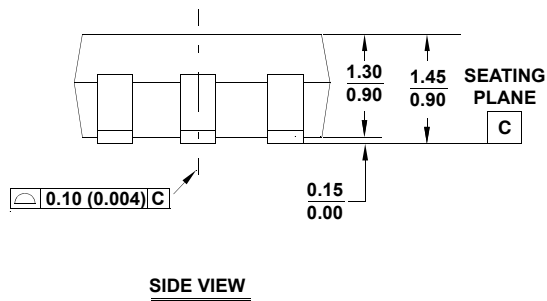
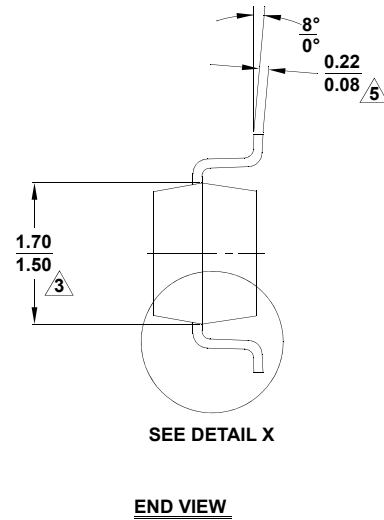
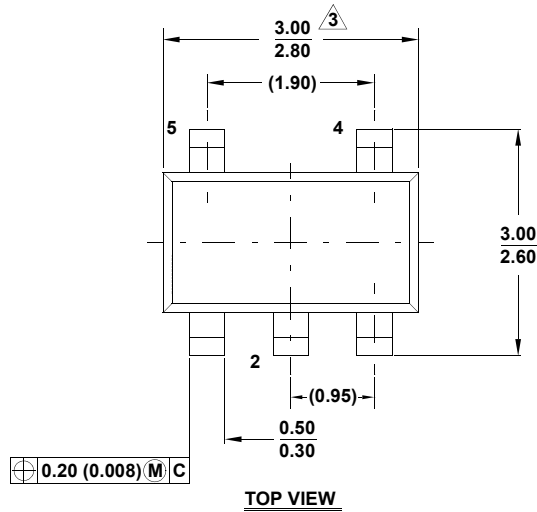

**NOTES:**

1. Dimensioning and tolerance per ASME Y14.5M-1994.
2. Package conforms to EIAJ SC-74 and JEDEC MO178AA.
3. Package length and width are exclusive of mold flash, protrusions, or gate burrs.
4. Footlength measured at reference to gauge plane.
5. Lead thickness applies to the flat section of the lead between 0.08mm and 0.15mm from the lead tip.
6. Controlling dimension: MILLIMETER.  
Dimensions in ( ) for reference only.

## Looking for pricing, stock, or lifecycle information?

Click below to explore more details on WIN SOURCE:

 [View ISL43111BZ on WIN SOURCE](#)

 [Intersil Information](#)

## Optimize Your Supply Chain with WIN SOURCE Solutions

-  Global Sourcing Solution
-  Obsolete Management
-  Cost Control Management
-  Shortage Management
-  Alternative Solution
-  Excess Inventory Management