



**THE DATASHEET OF
ISL3294EFHZ-T**



ISL3293E, ISL3294E, ISL3295E ISL3296E, ISL3297E, ISL3298E

FN6544
Rev 3.00
September 25, 2015

The Intersil [ISL3293E](#), [ISL3294E](#), [ISL3295E](#), [ISL3296E](#), [ISL3297E](#), [ISL3298E](#) are ± 16.5 kV HBM ESD Protected (7kV IEC61000 contact), 3.0V to 5.5V powered, single transmitters for balanced communication using the RS-485 and RS-422 standards. These drivers have very low bus currents (± 40 mA), so they present less than a “1/8 unit load” to the RS-485 bus. This allows more than 256 transmitters on the network without violating the RS-485 specification’s 32 unit load maximum, and without using repeaters.

Hot Plug circuitry ensures that the Tx outputs remain in a high impedance state while the power supply stabilizes.

The ISL3293E, ISL3294E, ISL3296E, ISL3297E utilize slew rate limited drivers which reduce EMI, and minimize reflections from improperly terminated transmission lines, or from unterminated stubs in multidrop and multipoint applications. Drivers on the ISL3295E and ISL3298E are not limited, so they can achieve the 20Mbps data rate. All versions are offered in industrial and extended industrial (-40°C to $+125^{\circ}\text{C}$) temperature ranges.

A 26% smaller footprint is available with the ISL3296E, ISL3297E, ISL3298E’s TDFN package. These devices also feature a logic supply pin (V_L) that sets the switching points of the DE and DI inputs to be compatible with a lower supply voltage in mixed voltage systems.

For companion single RS-485 receivers in micro packages, please see the [ISL3280E](#), [ISL3281E](#), [ISL3282E](#), [ISL3283E](#), [ISL3284E](#) datasheet.

Features

- High ESD protection on RS-485 outputs ± 16.5 kV HBM
 - IEC61000-4-2 contact test method ± 7 kV
 - Class 3 ESD level on all other pins. >8 kV HBM
- Specified for $+125^{\circ}\text{C}$ operation ($V_{CC} \leq 3.6$ V only)
- Logic supply pin (V_L) eases operation in mixed supply systems (ISL3296E through ISL3298E only)
- Hot plug - Tx outputs remain three-state during power-up
- Low Tx leakage allows >256 devices on the bus
- High data rates. up to 20Mbps
- Low quiescent supply current. 150 μ A (max)
 - Very low shutdown supply current 1 μ A (max)
- -7 V to $+12$ V common-mode output voltage range ($V_{CC} \leq 3.6$ V only)
- Current limiting and thermal shutdown for driver overload protection ($V_{CC} \leq 3.6$ V only)
- Tri-statable Tx outputs
- 5V tolerant logic inputs when $V_{CC} \leq 5$ V
- Pb-free (RoHS compliant)

Applications

- Clock distribution
- High node count systems
- Space constrained systems
- Security camera networks
- Building environmental control/lighting systems
- Industrial/process control networks

TABLE 1. SUMMARY OF FEATURES

PART NUMBER	FUNCTION	DATA RATE (Mbps)	SLEW RATE LIMITED?	HOT PLUG?	V_L PIN?	TX ENABLE? (Note 11)	MAXIMUM QUIESCENT I_{CC} (μ A)	LOW POWER SHUTDOWN?	PIN COUNT
ISL3293E (No longer available or supported, recommended replacement: ISL32613E)	1 Tx	0.25	YES	YES	NO	YES	150	YES	6 Ld SOT
ISL3294E (No longer available or supported, recommended replacement: ISL32614E)	1 Tx	0.5	YES	YES	NO	YES	150	YES	6 Ld SOT
ISL3295E	1 Tx	20	NO	YES	NO	YES	150	YES	6 Ld SOT
ISL3296E (No longer available or supported)	1 Tx	0.25	YES	YES	YES	YES	150	YES	8 Ld TDFN
ISL3297E (No longer available or supported)	1 Tx	0.5	YES	YES	YES	YES	150	YES	8 Ld TDFN
ISL3298E	1 Tx	20	NO	YES	YES	YES	150	YES	8 Ld TDFN

Pin Configurations

ISL3293E, ISL3294E, ISL3295E
(6 LD SOT-23)
TOP VIEW

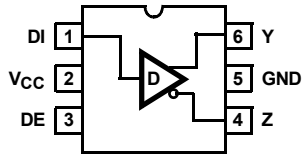

ISL3296E, ISL3297E, ISL3298E
(8 LD TDFN)
TOP VIEW

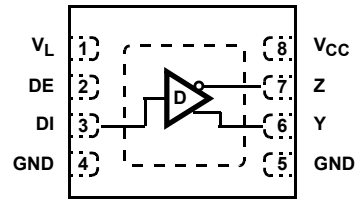

NOTE: BOTH GND PINS MUST BE CONNECTED

Truth Tables

TRANSMITTING			
INPUTS		OUTPUTS	
DE (Note 11)	DI	Z	Y
1	1	0	1
1	0	1	0
0	X	High-Z *	High-Z *

NOTE: *Shutdown Mode

Pin Descriptions

PIN NAME	FUNCTION
DE	Driver output enable. The driver outputs, Y and Z, are enabled by bringing DE high, and are high impedance when DE is low. If the driver enable function isn't needed, connect DE to V _{CC} (or V _L) through a 1kΩ to 3kΩ resistor.
DI	Driver input. A low on DI forces output Y low and output Z high. Similarly, a high on DI forces output Y high and output Z low.
GND	Ground connection. This is also the potential of the TDFN thermal pad.
Y	±15kV HBM, ±7kV IEC61000 (contact method) ESD Protected RS-485/422 level, noninverting transmitter output.
Z	±15kV HBM, ±7kV IEC61000 (contact method) ESD Protected RS-485/422 level, inverting transmitter output.
V _{CC}	System power supply input (3.0V to 5.5V). On devices with a V _L pin powered from a separate supply, power-up V _{CC} first.
V _L	Logic-level supply which sets the V _{IL} /V _{IH} levels for the DI and DE pins (ISL3296E, ISL3297E, ISL3298E only). If V _L and V _{CC} are different supplies, power-up this supply after V _{CC} , and keep V _L ≤ V _{CC} .

Ordering Information

PART NUMBER (Notes 1, 2, 3)	PART MARKING (Note 4)	TEMP. RANGE (°C)	PACKAGE (RoHS Compliant)	PKG. DWG. #
ISL3293EFHZ-T (No longer available or supported, recommended replacement: ISL32613E)	293F	-40 to +125	6 Ld SOT-23	P6.064
ISL3293EIHZ-T (No longer available or supported, recommended replacement: ISL32613E)	293I	-40 to +85	6 Ld SOT-23	P6.064
ISL3294EFHZ-T (No longer available or supported, recommended replacement: ISL32614E)	294F	-40 to +125	6 Ld SOT-23	P6.064
ISL3294EIHZ-T (No longer available or supported, recommended replacement: ISL32614E)	294I	-40 to +85	6 Ld SOT-23	P6.064
ISL3295EFHZ-T	295F	-40 to +125	6 Ld SOT-23	P6.064
ISL3295EIHZ-T	295I	-40 to +85	6 Ld SOT-23	P6.064
ISL3296EFRTZ-T (No longer available or supported)	96F	-40 to +125	8 Ld TDFN	L8.2x3A
ISL3296EIRTZ-T (No longer available or supported)	96I	-40 to +85	8 Ld TDFN	L8.2x3A
ISL3297EFRTZ-T (No longer available or supported)	97F	-40 to +125	8 Ld TDFN	L8.2x3A
ISL3297EIRTZ-T (No longer available or supported)	97I	-40 to +85	8 Ld TDFN	L8.2x3A
ISL3298EFRTZ-T	98F	-40 to +125	8 Ld TDFN	L8.2x3A
ISL3298EIRTZ-T (No longer available or supported)	98I	-40 to +85	8 Ld TDFN	L8.2x3A

NOTES:

1. These Intersil Pb-free plastic packaged products employ special Pb-free material sets, molding compounds/die attach materials, and 100% matte tin plate plus anneal (e3 termination finish, which is RoHS compliant and compatible with both SnPb and Pb-free soldering operations). Intersil Pb-free products are MSL classified at Pb-free peak reflow temperatures that meet or exceed the Pb-free requirements of IPC/JEDEC J STD-020.
2. Please refer to [TB347](#) for details on reel specifications.
3. For Moisture Sensitivity Level (MSL), please see product information page for [ISL3293E](#), [ISL3294E](#), [ISL3295E](#), [ISL3296E](#), [ISL3297E](#), [ISL3298E](#). For more information on MSL, please see tech brief [TB363](#).
4. SOT-23 "PART MARKING" is branded on the bottom side.

Typical Operating Circuits

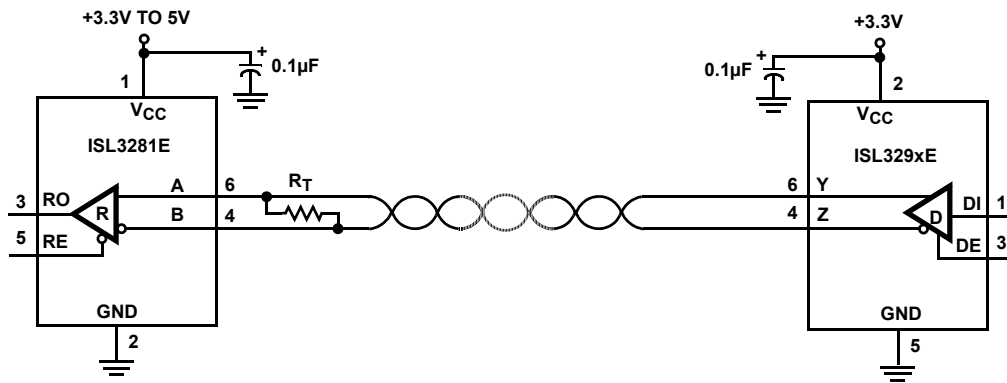

FIGURE 1. NETWORK WITH ENABLES

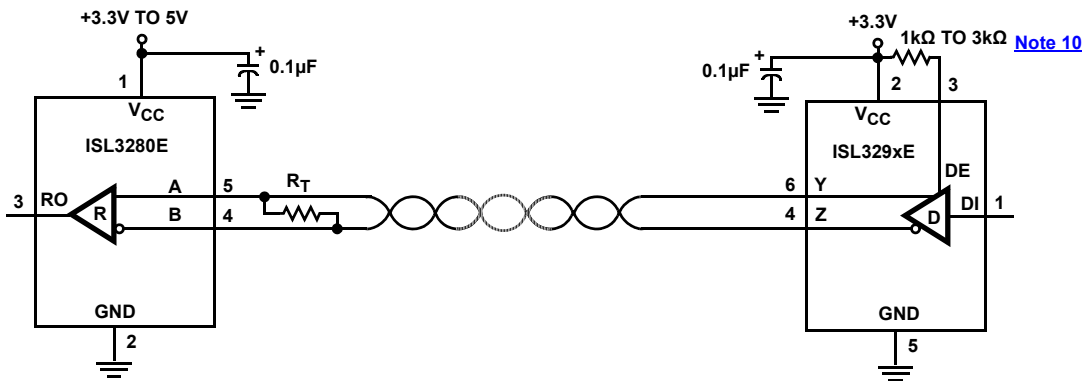

FIGURE 2. NETWORK WITHOUT ENABLE

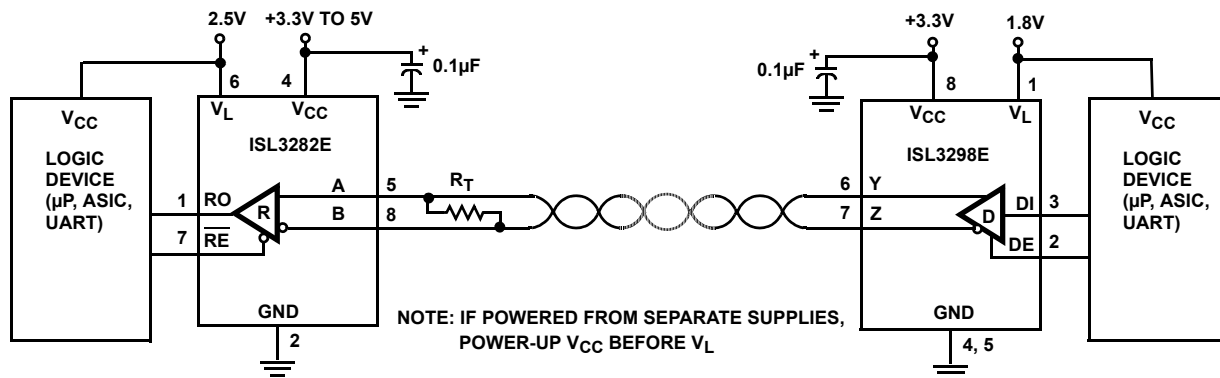

FIGURE 3. NETWORK WITH VL PIN FOR INTERFACING TO LOWER VOLTAGE LOGIC DEVICES

Absolute Maximum Ratings

V _{CC} to GND	-0.3V to 7V
V _L to GND (ISL3296E thru ISL3298E Only)	-0.3V to (V _{CC} + 0.3V)
Input Voltages	
DI, DE	-0.3V to 7V
Output Voltages	
Y, Z (V _{CC} ≤ 3.6V)	-8V to +13V
Y, Z (V _{CC} > 3.6V)	-0.5V to V _{CC} + 0.5V
Short-circuit Duration	
Y, Z (V _{CC} ≤ 3.6V)	Continuous
Y, Z (V _{CC} > 3.6V, Note 13)	1s at <300mA
ESD Rating	See Electrical Specifications on page 6

Thermal Information

Thermal Resistance (Typical)	θ _{JA} (°C/W)	θ _{JC} (°C/W)
6 Ld SOT-23 Package (Note 5)	177	N/A
8 Ld TDFN Package (Notes 6, 7)	65	8
Maximum Junction Temperature (Plastic Package)	+150°C	
Maximum Storage Temperature Range	-65°C to +150°C	
Pb-free Reflow Profile	see TB493	

Operating Conditions

Temperature Range	
F Suffix (V _{CC} ≤ 3.6V only)	-40°C to +125°C
I Suffix	-40°C to +85°C

CAUTION: Do not operate at or near the maximum ratings listed for extended periods of time. Exposure to such conditions may adversely impact product reliability and result in failures not covered by warranty.

NOTES:

- θ_{JA} is measured with the component mounted on a high effective thermal conductivity test board in free air. See Tech Brief [TB379](#) for details.
- θ_{JA} is measured in free air with the component mounted on a high effective thermal conductivity test board with “direct attach” features. See Tech Brief [TB379](#).
- For θ_{JC}, the “case temp” location is the center of the exposed metal pad on the package underside.

Electrical Specifications

Test Conditions: V_{CC} = 3.0V to 5.5V, V_L = V_{CC} (ISL3296E, ISL3297E, ISL3298E only), typicals are at T_A = +25°C, unless otherwise specified. ([Note 8](#))

PARAMETER	SYMBOL	TEST CONDITIONS	TEMP (°C)	MIN (Note 12)	TYP (Note 14)	MAX (Note 12)	UNIT	
DC CHARACTERISTICS								
Driver Differential V _{OUT}	V _{OD}	R _L = 100Ω (RS-422) (Figure 4A)	V _{CC} ≥ 3.15V	Full	2	2.3	-	V
			V _{CC} ≥ 4.5V	Full	3	3.8	-	V
		R _L = 54Ω (RS-485) (Figure 4A)	V _{CC} ≥ 3.0V	Full	1.5	2	V _{CC}	V
			V _{CC} ≥ 4.5V	Full	2.5	3.4	V _{CC}	V
		No load	Full	-	-	V _{CC}		
		R _L = 60Ω, -7V ≤ V _{CM} ≤ 12V (Figure 4B)	Full	1.5	2, 3.4	-	V	
Change in Magnitude of Driver Differential V _{OUT} for Complementary Output States	ΔV _{OD}	R _L = 54Ω or 100Ω (Figure 4A)	Full	-	0.01	0.2	V	
Driver Common-mode V _{OUT}	V _{OC}	R _L = 54Ω or 100Ω (Figure 4A)	V _{CC} ≤ 3.6V	Full	-	2	3	V
			V _{CC} ≤ 5.5V	Full	-	-	3.2	V
Change in Magnitude of Driver Common-mode V _{OUT} for Complementary Output States	ΔV _{OC}	R _L = 54Ω or 100Ω (Figure 4A)	Full	-	0.01	0.2	V	
Input High Voltage (DI, DE)	V _{IH1}	V _L = V _{CC} if ISL3296E, ISL3297E, ISL3298E	V _{CC} ≤ 3.6V	Full	2.2	-	-	V
	V _{CC} ≤ 5.5V		Full	3	-	-	V	
	V _{IH3}	2.7V ≤ V _L < 3.0V (ISL3296E, ISL3297E, ISL3298E only)	Full	2	-	-	V	
	V _{IH4}	2.3V ≤ V _L < 2.7V (ISL3296E, ISL3297E, ISL3298E only)	Full	1.65	-	-	V	
	V _{IH5}	1.6V ≤ V _L < 2.3V (ISL3296E, ISL3297E, ISL3298E only)	Full	0.7*V _L	-	-	V	
	V _{IH6}	1.35V ≤ V _L < 1.6V (ISL3296E, ISL3297E, ISL3298E only)	25	-	0.5*V _L	-	V	

Electrical Specifications Test Conditions: $V_{CC} = 3.0V$ to $5.5V$, $V_L = V_{CC}$ (ISL3296E, ISL3297E, ISL3298E only), typicals are at $T_A = +25^\circ C$, unless otherwise specified. (Note 8) (Continued)

PARAMETER	SYMBOL	TEST CONDITIONS	TEMP (°C)	MIN (Note 12)	TYP (Note 14)	MAX (Note 12)	UNIT	
Input Low Voltage (DI, DE)	V_{IL1}	$V_L = V_{CC}$ if ISL3296E, ISL3297E, ISL3298E	Full	-	-	0.8	V	
	V_{IL2}	$V_L \geq 2.7V$ (ISL3296E, ISL3297E, ISL3298E only)	Full	-	-	0.8	V	
	V_{IL3}	$2.3V \leq V_L < 2.7V$ (ISL3296E, ISL3297E, ISL3298E only)	Full	-	-	0.65	V	
	V_{IL4}	$1.6V \leq V_L < 2.3V$ (ISL3296E, ISL3297E, ISL3298E only)	Full	-	-	$0.22 \cdot V_L$	V	
	V_{IL5}	$1.35V \leq V_L < 1.6V$ (ISL3296E, ISL3297E, ISL3298E only)	25	-	$0.3 \cdot V_L$	-	V	
Logic Input Current	I_{IN}	DI = DE = 0V or V_{CC} (Note 11)	Full	-2	-	2	μA	
Output Leakage Current (Y, Z, Note 11)	I_{OZ}	DE = 0V, $V_{CC} = 0V, 3.6V, \text{ or } 5.5V$	$V_{IN} = 12V$	Full	-	0.1	40	μA
			$V_{IN} = -7V$	Full	-40	-10	-	μA
Driver Short-circuit Current, $V_O = \text{High or Low}$ (Note 9)	I_{OSD1}	DE = V_{CC} , $-7V \leq V_O \leq 12V$, $V_{CC} \leq 3.6V$		Full	-	-	± 250	mA
		DE = V_{CC} , $0V \leq V_O \leq V_{CC}$, $V_{CC} > 3.6V$ (Note 13)		Full	-	-	± 450	mA
Thermal Shutdown Threshold	T_{SD}		Full	-	160	-	$^\circ C$	
SUPPLY CURRENT								
No-load Supply Current	I_{CC}	DI = 0V or V_{CC}	DE = V_{CC}	Full	-	120	150	μA
Shutdown Supply Current	I_{SHDN}	DE = 0V, DI = 0V or V_{CC}		Full	-	0.01	1	μA
ESD PERFORMANCE								
RS-485 Pins (Y, Z)		Human Body Model, from bus pins to GND	25	-	± 16.5	-	kV	
		IEC61000 Contact, from bus pins to GND	25	-	± 7	-	kV	
All Pins		HBM, per MIL-STD-883 Method 3015	25	-	± 8	-	kV	
		Machine Model	25	-	± 400	-	V	
DRIVER SWITCHING CHARACTERISTICS (ISL3293E, ISL3296E, 250kbps)								
Maximum Data Rate	f_{MAX}	$V_{OD} = \pm 1.5V$, $C_D = 820pF$ (Figure 7)	Full	250	-	-	kbps	
Driver Single-ended Output Delay	t_{SD}	$R_{DIFF} = 54\Omega$, $C_D = 50pF$ (Figure 5)	Full	400	1350	1700	ns	
Part-to-part Output Delay Skew	t_{SKPP}	$R_{DIFF} = 54\Omega$, $C_D = 50pF$ (Figure 5, Note 10)	Full	-	-	900	ns	
Driver Single-ended Output Skew	t_{SSK}	$R_{DIFF} = 54\Omega$, $C_D = 50pF$ (Figure 5)	Full	-	600	750	ns	
Driver Differential Output Delay	t_{DD}	$R_{DIFF} = 54\Omega$, $C_D = 50pF$ (Figure 5)	Full	400	1100	1500	ns	
Driver Differential Output Skew	t_{DSK}	$R_{DIFF} = 54\Omega$, $C_D = 50pF$ (Figure 5)	Full	-	4, 1	30	ns	
Driver Differential Rise or Fall Time	t_R, t_F	$R_{DIFF} = 54\Omega$, $C_D = 50pF$ (Figure 5)	$V_{CC} \leq 3.6V$	Full	400	960	1500	ns
			$V_{CC} = 5V$	25	-	1300	-	ns
Driver Enable to Output High	t_{ZH}	$R_L = 500\Omega$, $C_L = 50pF$, SW = GND (Figure 6)	Full	-	100, 60	250	ns	
Driver Enable to Output Low	t_{ZL}	$R_L = 500\Omega$, $C_L = 50pF$, SW = V_{CC} (Figure 6)	Full	-	60, 35	250	ns	
Driver Disable from Output High	t_{HZ}	$R_L = 500\Omega$, $C_L = 50pF$, SW = GND (Figure 6)	Full	-	30, 22	60	ns	
Driver Disable from Output Low	t_{LZ}	$R_L = 500\Omega$, $C_L = 50pF$, SW = V_{CC} (Figure 6)	Full	-	25, 20	60	ns	
DRIVER SWITCHING CHARACTERISTICS (ISL3294E, ISL3297E, 500kbps)								
Maximum Data Rate	f_{MAX}	$V_{OD} = \pm 1.5V$, $C_D = 820pF$ (Figure 7)	Full	500	-	-	kbps	
Driver Single-ended Output Delay	t_{SD}	$R_{DIFF} = 54\Omega$, $C_D = 50pF$ (Figure 5)	Full	200	340	500	ns	
Part-to-part Output Delay Skew	t_{SKPP}	$R_{DIFF} = 54\Omega$, $C_D = 50pF$ (Figure 5, Note 10)	Full	-	-	300	ns	
Driver Single-ended Output Skew	t_{SSK}	$R_{DIFF} = 54\Omega$, $C_D = 50pF$ (Figure 5)	Full	-	30, 80	150	ns	
Driver Differential Output Delay	t_{DD}	$R_{DIFF} = 54\Omega$, $C_D = 50pF$ (Figure 5)	Full	200	345	500	ns	

Electrical Specifications Test Conditions: $V_{CC} = 3.0V$ to $5.5V$, $V_L = V_{CC}$ (ISL3296E, ISL3297E, ISL3298E only), typicals are at $T_A = +25^\circ C$, unless otherwise specified. (Note 8) (Continued)

PARAMETER	SYMBOL	TEST CONDITIONS	TEMP (°C)	MIN (Note 12)	TYP (Note 14)	MAX (Note 12)	UNIT	
Driver Differential Output Skew	t_{DSK}	$R_{DIFF} = 54\Omega$, $C_D = 50pF$ (Figure 5)	Full	-	2	30	ns	
Driver Differential Rise or Fall Time	t_R, t_F	$R_{DIFF} = 54\Omega$, $C_D = 50pF$ (Figure 5)	Full	200	350	800	ns	
Driver Enable to Output High	t_{ZH}	$R_L = 500\Omega$, $C_L = 50pF$, SW = GND (Figure 6)	Full	-	100, 60	250	ns	
Driver Enable to Output Low	t_{ZL}	$R_L = 500\Omega$, $C_L = 50pF$, SW = V_{CC} (Figure 6)	Full	-	60, 35	250	ns	
Driver Disable from Output High	t_{HZ}	$R_L = 500\Omega$, $C_L = 50pF$, SW = GND (Figure 6)	Full	-	30, 22	60	ns	
Driver Disable from Output Low	t_{LZ}	$R_L = 500\Omega$, $C_L = 50pF$, SW = V_{CC} (Figure 6)	Full	-	25, 20	60	ns	
DRIVER SWITCHING CHARACTERISTICS (ISL3295E, ISL3298E, 20Mbps)								
Maximum Data Rate	f_{MAX}	$V_{OD} = \pm 1.5V$, $C_D = 360pF$ (Figure 7)	Full	20	-	-	Mbps	
Driver Single-ended Output Delay	t_{SD}	$R_{DIFF} = 54\Omega$, $C_D = 50pF$ (Figure 5)	$V_L = V_{CC}$	Full	15	29, 23	42	ns
			$V_L \geq 1.8V$	25	-	32	-	ns
			$V_L = 1.5V$	25	-	36	-	ns
			$V_L = 1.35V$	25	-	40	-	ns
Part-to-part Output Delay Skew	t_{SKPP}	$R_{DIFF} = 54\Omega$, $C_D = 50pF$ (Figure 5, Note 10)	Full	-	-	25	ns	
Driver Single-ended Output Skew	t_{SSK}	$R_{DIFF} = 54\Omega$, $C_D = 50pF$ (Figure 5)	$V_L = V_{CC}$	Full	-	3	7	ns
			$V_L \geq 1.8V$	25	-	3	-	ns
			$V_L = 1.5V$	25	-	4	-	ns
			$V_L = 1.35V$	25	-	5	-	ns
Driver Differential Output Delay	t_{DD}	$R_{DIFF} = 54\Omega$, $C_D = 50pF$ (Figure 5)	$V_L = V_{CC}$	Full	-	29, 22	42	ns
			$V_L \geq 1.8V$	25	-	32	-	ns
			$V_L = 1.5V$	25	-	36	-	ns
			$V_L = 1.35V$	25	-	42	-	ns
Driver Differential Output Skew	t_{DSK}	$R_{DIFF} = 54\Omega$, $C_D = 50pF$ (Figure 5)	$V_L = V_{CC} \leq 3.6V$	Full	-	0.5	3	ns
			$V_L = V_{CC} = 5V$	25	-	2	-	ns
			$V_L \geq 1.8V$	25	-	0.5, 1	-	ns
			$V_L \geq 1.5V$	25	-	1, 2	-	ns
			$V_L = 1.35V$	25	-	2, 4	-	ns
Driver Differential Rise or Fall Time	t_R, t_F	$R_{DIFF} = 54\Omega$, $C_D = 50pF$ (Figure 5)	$V_L = V_{CC}$	Full	-	9	15	ns
			$V_L \geq 1.35V$	25	-	9	-	ns
Driver Enable to Output High	t_{ZH}	$R_L = 500\Omega$, $C_L = 50pF$, SW = GND (Figure 6)	Full	-	100, 60	250	ns	
Driver Enable to Output Low	t_{ZL}	$R_L = 500\Omega$, $C_L = 50pF$, SW = V_{CC} (Figure 6)	Full	-	60, 35	250	ns	
Driver Disable from Output High	t_{HZ}	$R_L = 500\Omega$, $C_L = 50pF$, SW = GND (Figure 6)	Full	-	30, 22	60	ns	
Driver Disable from Output Low	t_{LZ}	$R_L = 500\Omega$, $C_L = 50pF$, SW = V_{CC} (Figure 6)	Full	-	25, 20	60	ns	

NOTES:

- All currents into device pins are positive; all currents out of device pins are negative. All voltages are referenced to device ground unless otherwise specified.
- Applies to peak current. See "Typical Performance Curves" on page 11 for more information.
- t_{SKPP} is the magnitude of the difference in propagation delays of the specified terminals of two units tested with identical test conditions (V_{CC} , temperature, etc.).
- If the driver enable function isn't needed, connect DE to V_{CC} (or V_L) through a 1k Ω to 3k Ω resistor.
- Parts are 100% tested at +25°C. Over-temperature limits established by characterization and are not production tested.
- Due to the high short-circuit current at $V_{CC} > 3.6V$, the outputs must not be shorted outside the range of GND to V_{CC} or damage may occur. To prevent excessive power dissipation that may damage the output, the short-circuit current should be limited to $\leq 300mA$ during testing. It is best to use an external resistor for this purpose, since the current limiting on the V_O supply may respond too slowly to protect the output.
- Typicals are measured at $V_{CC} = 3.3V$ for parameters specified with $3V \leq V_{CC} \leq 3.6V$, and are measured at $V_{CC} = 5V$ for parameters specified with $4.5V \leq V_{CC} \leq 5.5V$. If V_{CC} isn't specified, then a single "TYP" entry applies to both $V_{CC} = 3.3V$ and $5V$, and two entries separated by a comma refer to $V_{CC} = 3.3V$ and $5V$, respectively.

Test Circuits and Waveforms

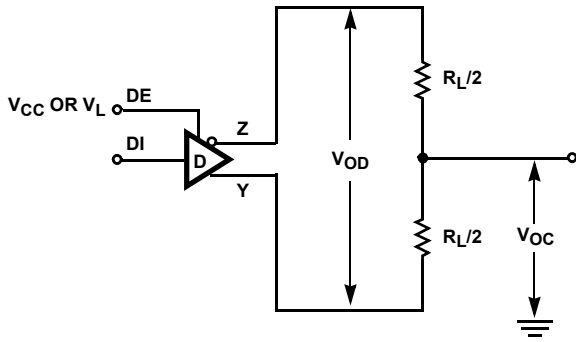

FIGURE 4A. V_{OD} AND V_{OC}

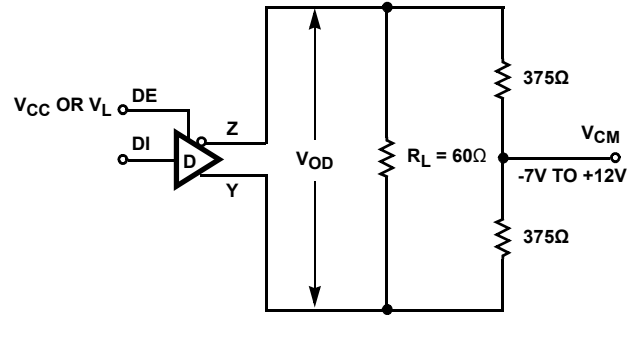

FIGURE 4B. V_{OD} WITH COMMON-MODE LOAD

FIGURE 4. DC DRIVER TEST CIRCUITS

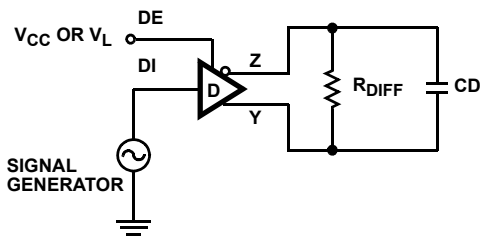
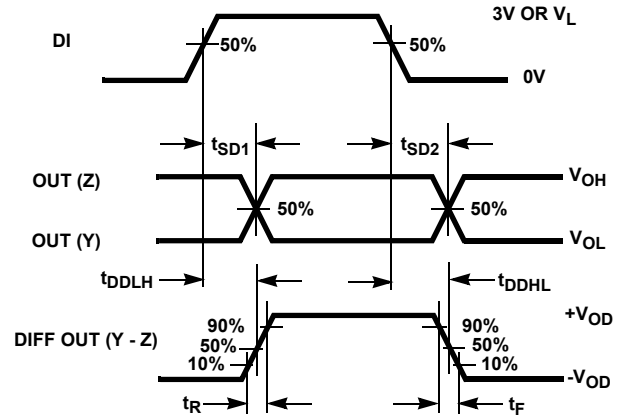

FIGURE 5A. TEST CIRCUIT

FIGURE 5. DRIVER PROPAGATION DELAY AND DIFFERENTIAL TRANSITION TIMES



$$t_{SSK} = |t_{SD1(Y)} - t_{SD2(Z)}| \text{ OR } |t_{SD1(Z)} - t_{SD2(Y)}| \quad t_{DSK} = |t_{DDLH} - t_{DDHL}|$$

FIGURE 5B. MEASUREMENT POINTS

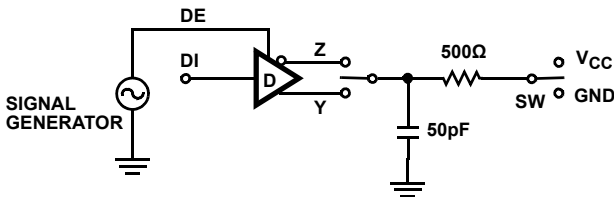

PARAMETER	OUTPUT	DI	SW
t_{HZ}	Y/Z	1/0	GND
t_{LZ}	Y/Z	0/1	V_{CC}
t_{ZH}	Y/Z	1/0	GND
t_{ZL}	Y/Z	0/1	V_{CC}

FIGURE 6A. TEST CIRCUIT

FIGURE 6. DRIVER ENABLE AND DISABLE TIMES

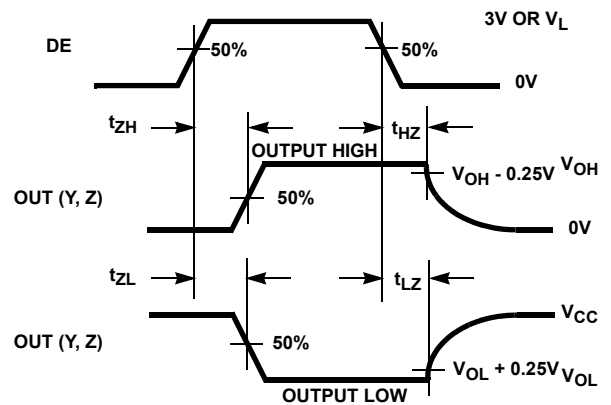

FIGURE 6B. MEASUREMENT POINTS

Test Circuits and Waveforms (Continued)

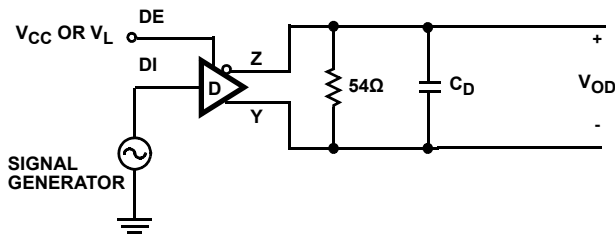

FIGURE 7A. TEST CIRCUIT

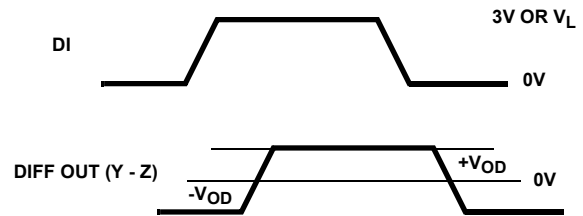

FIGURE 7B. MEASUREMENT POINTS

FIGURE 7. DRIVER DATA RATE

Application Information

RS-485 and RS-422 are differential (balanced) data transmission standards for use in long haul or noisy environments. RS-422 is a subset of RS-485, so RS-485 transmitters and receivers are also RS-422 compliant. RS-422 is a point-to-multipoint (multidrop) standard, which allows only one driver and up to 10 (assuming one unit load devices) receivers on each bus. RS-485 is a true multipoint standard, which allows up to 32 one unit load devices (any combination of drivers and receivers) on each bus. To allow for multipoint operation, the RS-485 specification requires that drivers must handle bus contention without sustaining any damage.

Another important advantage of RS-485 is the extended Common-Mode Range (CMR), which specifies that the driver outputs and receiver inputs withstand signals that range from +12V to -7V. RS-422 and RS-485 are intended for runs as long as 4000', so the wide CMR is necessary to handle ground potential differences, as well as voltages induced in the cable by external fields.

Driver Features

These RS-485/RS-422 drivers are differential output devices that delivers at least 1.5V across a 54Ω load (RS-485) and at least 2V across a 100Ω load (RS-422). The drivers feature low propagation delay skew to maximize bit width and to minimize EMI.

All drivers are tri-statable via the active high DE input. If the Tx enable function is not needed, tie DE to V_{CC} (or V_L) through a 1kΩ to 3kΩ resistor.

The 250kbps and 500kbps driver outputs are slew rate limited to minimize EMI, and to reduce reflections in unterminated or improperly terminated networks. Outputs of the ISL3295E and ISL3298E drivers are not limited, so faster output transition times allow data rates of at least 20Mbps.

Wide Supply Range

The ISL3293E through ISL3298E are optimized for 3.3V operation, but can be operated with supply voltages as high as 5.5V. These devices meet the RS-422 and RS-485 specifications for supply voltages less than 4V, and are RS-422 and RS-485 compatible for supplies greater than 4V. Operation at +125 °C requires V_{CC} ≤ 3.6V, while 5V operation requires adding output current limiting resistors (as described in the [“Driver Overload Protection” on page 10](#)) if output short-circuits (e.g., from bus contention) are a possibility.

5.5V Tolerant Logic Pins

Logic input pins (DI, DE) contain no ESD nor parasitic diodes to V_{CC} (nor to V_L), so they withstand input voltages exceeding 5.5V regardless of the V_{CC} and V_L voltages.

Logic Supply (V_L Pin, ISL3296E through ISL3298E)

Note: If powered from separate supplies, power-up V_{CC} before powering up the V_L supply and keep V_L ≤ V_{CC}.

The ISL3296E through ISL3298E include a V_L pin that powers the logic inputs (DI and DE). These pins interface with “logic” devices such as UARTs, ASICs, and μcontrollers, and today most of these devices use power supplies significantly lower than 3.3V. Thus, the logic device’s low V_{OH} might not exceed the V_{IH} of a 3.3V or 5V powered DI or DE input. Connecting the V_L pin to the power supply of the logic device (as shown in [Figure 8](#)) reduces the DI and DE input switching points to values compatible with the logic device’s output levels. Tailoring the logic pin input switching points and output levels to the supply voltage of the UART, ASIC, or μcontroller eliminates the need for a level shifter/translator between the two ICs.

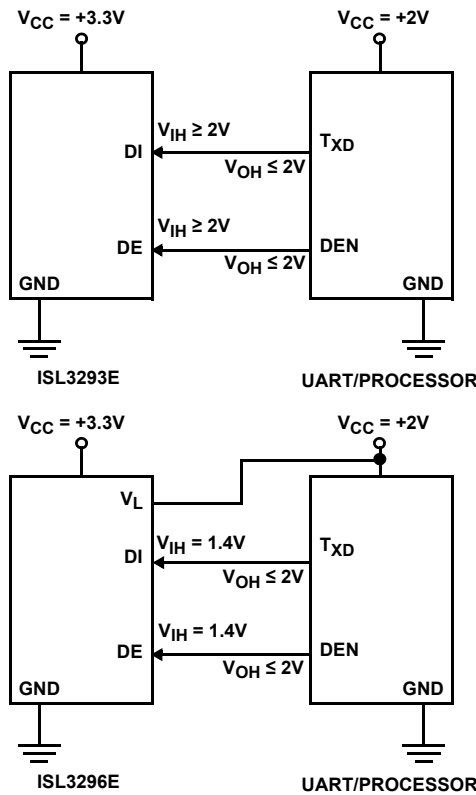

FIGURE 8. USING V_L PIN TO ADJUST LOGIC LEVELS

V_L can be anywhere from V_{CC} down to 1.35V, but the input switching points may not provide enough noise margin and 20Mbps data rates may not be achievable, when $V_L < 1.5V$. Table 2 indicates typical V_{IH} and V_{IL} values for various V_L settings so the user can ascertain whether or not a particular V_L voltage meets his needs.

TABLE 2. V_{IH} AND V_{IL} vs V_L FOR $V_{CC} = 3.3V$ OR $5V$

V_L (V)	V_{IH} (V)	V_{IL} (V)
1.35	0.7	0.4
1.5	0.8	0.5
1.8	0.9	0.7
2.3	1.1	1.0
2.7	1.3	1.1
3.3	1.5	1.4
5.0 (i.e., V_{CC})	2.7	2.3

The V_L supply current (I_L) is typically much less than 20 μ A, as shown in Figure 12 on page 11, when DE and DI are above/below V_{IH}/V_{IL} .

Hot Plug Function

When a piece of equipment powers up, there is a period of time where the processor or ASIC driving the RS-485 control line (DE) is unable to ensure that the RS-485 Tx outputs are kept disabled. If the equipment is connected to the bus, a driver activating prematurely during power-up may crash the bus. To avoid this scenario, the ISL329xE family incorporates a “Hot Plug” function. During power-up, circuitry monitoring V_{CC} ensures that the Tx

outputs remain disabled for a period of time, regardless of the state of DE. This gives the processor/ASIC a chance to stabilize and drive the RS-485 control lines to the proper states.

ESD Protection

All pins on these devices include class 3 (8kV) Human Body Model (HBM) ESD protection structures, but the RS-485 pins (driver outputs) incorporate advanced structures allowing them to survive ESD events in excess of $\pm 16.5kV$ HBM and $\pm 7kV$ to the IEC61000 contact test method. The RS-485 pins are particularly vulnerable to ESD damage because they typically connect to an exposed port on the exterior of the finished product. Simply touching the port pins, or connecting a cable, can cause an ESD event that might destroy unprotected ICs. These new ESD structures protect the device whether or not it is powered up and without degrading the RS-485 common-mode range of -7V to +12V. This built-in ESD protection eliminates the need for board level protection structures (e.g., transient suppression diodes) and the associated, undesirable capacitive load they present.

Data Rate, Cables and Terminations

RS-485/RS-422 are intended for network lengths up to 4000', but the maximum system data rate decreases as the transmission length increases. Devices operating at 20Mbps are limited to lengths less than 100', while the 250kbps versions can operate at full data rates with lengths of several 1000'.

Twisted pair is the cable of choice for RS-485/RS-422 networks. Twisted pair cables tend to pick up noise and other electromagnetically induced voltages as common-mode signals, which are effectively rejected by the differential receivers in these ICs.

Proper termination is imperative, when using the 20Mbps devices, to minimize reflections. Short networks using the 250kbps versions need not be terminated, but, terminations are recommended unless power dissipation is an overriding concern.

In point-to-point, or point-to-multipoint (single driver on bus) networks, the main cable should be terminated in its characteristic impedance (typically 120 Ω) at the end farthest from the driver. In multireceiver applications, stubs connecting receivers to the main cable should be kept as short as possible. Multipoint (multidriver) systems require that the main cable be terminated in its characteristic impedance at both ends. Stubs connecting a transmitter or receiver to the main cable should be kept as short as possible.

Driver Overload Protection

As stated previously, the RS-485 specification requires that drivers survive worst case bus contentions undamaged. These drivers meet this requirement, for $V_{CC} \leq 3.6V$, via driver output short-circuit current limits and on-chip thermal shutdown circuitry.

The driver output stages incorporate short-circuit current limiting circuitry, which ensures that the output current never exceeds the RS-485 specification, for $V_{CC} \leq 3.6V$, even at the common-mode voltage range extremes. Additionally, these devices utilize a foldback circuit which reduces the short-circuit current and thus the power dissipation, whenever the contending voltage exceeds either V_{CC} or GND.

In the event of a major short-circuit condition, devices also include a thermal shutdown feature that disables the drivers whenever the die temperature becomes excessive. This eliminates the power dissipation, allowing the die to cool. The drivers automatically reenables after the die temperature drops about +20°C. If the contention persists, the thermal shutdown/reenable cycle repeats until the fault is cleared.

At $V_{CC} > 3.6V$, the instantaneous short-circuit current is high enough that output stage damage may occur during short-circuit conditions to voltages outside of GND to V_{CC} , before the short-circuit limiting and thermal shutdown activate. For $V_{CC} = 5V$ operation, if output short-circuits are a possibility (e.g., due to bus contention), it is recommended that a 5Ω resistor be inserted in series with each output. This resistor limits the instantaneous current below levels that can cause damage. The driver V_{OD} at $V_{CC} = 5V$ is so large that this small added resistance has little impact.

High Temperature Operation

Due to power dissipation and instantaneous output short-circuit current levels at $V_{CC} = 5V$, these transmitters may not be operated at +125°C with $V_{CC} > 3.6V$.

At $V_{CC} = 3.6V$, even the SOT-23 versions may be operated at +125°C, while driving a 100', double terminated, CAT 5 cable at 20Mbps, without triggering the thermal SHDN circuit.

Low Power Shutdown Mode

These BiCMOS transmitters all use a fraction of the power required by their bipolar counterparts, but they also include a shutdown feature that reduces the already low quiescent I_{CC} to a 1μA trickle. These devices enter shutdown whenever the driver disables (DE = GND).

Typical Performance Curves

$V_{CC} = V_L = 3.3V, T_A = +25^\circ C$, unless otherwise specified.

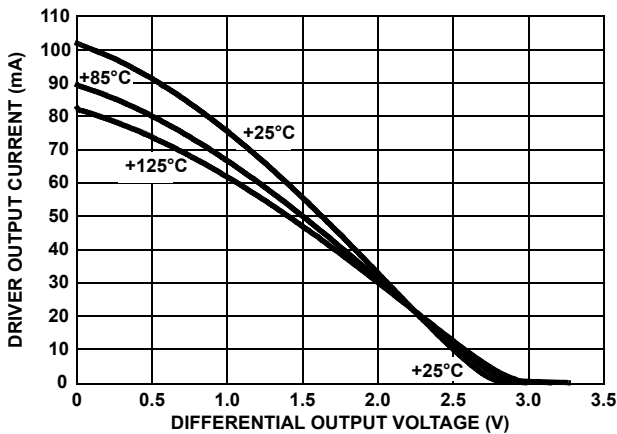

FIGURE 9. DRIVER OUTPUT CURRENT vs DIFFERENTIAL OUTPUT VOLTAGE

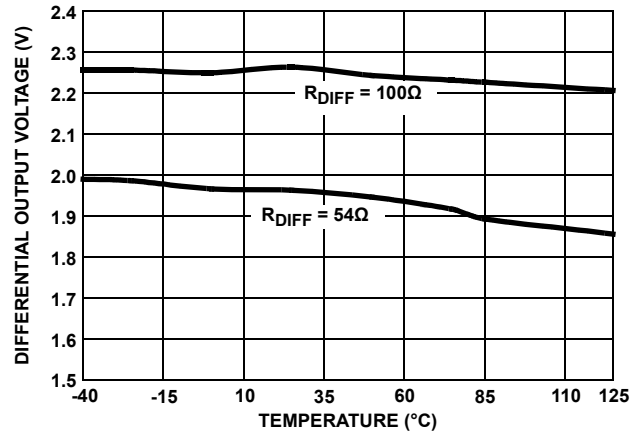

FIGURE 10. DRIVER DIFFERENTIAL OUTPUT VOLTAGE vs TEMPERATURE

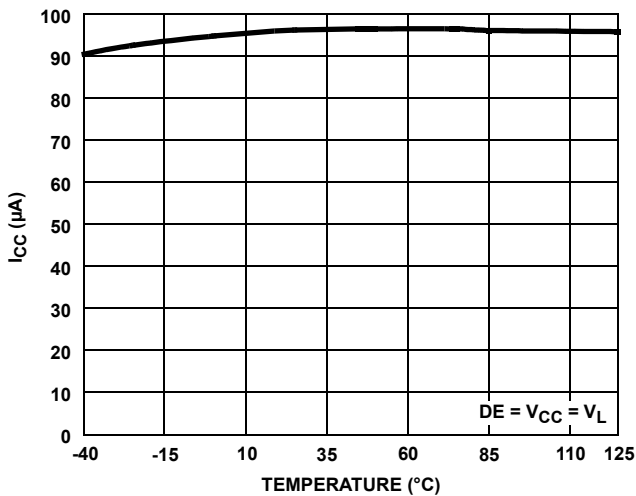

FIGURE 11. SUPPLY CURRENT vs TEMPERATURE

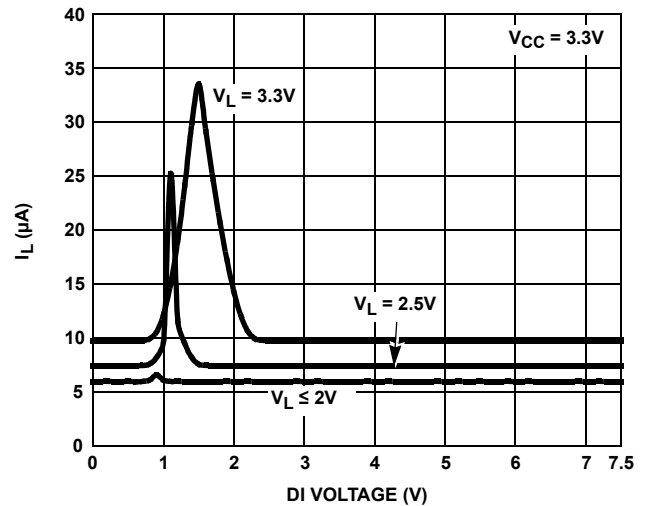

FIGURE 12. V_L SUPPLY CURRENT vs LOGIC PIN VOLTAGE

Typical Performance Curves $V_{CC} = V_L = 3.3V$, $T_A = +25^\circ C$, unless otherwise specified. (Continued)

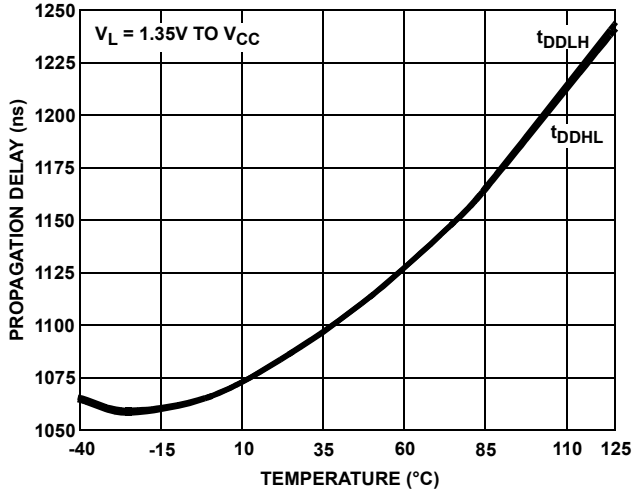

FIGURE 13. DRIVER DIFFERENTIAL PROPAGATION DELAY vs TEMPERATURE (ISL3293E, ISL3296E)

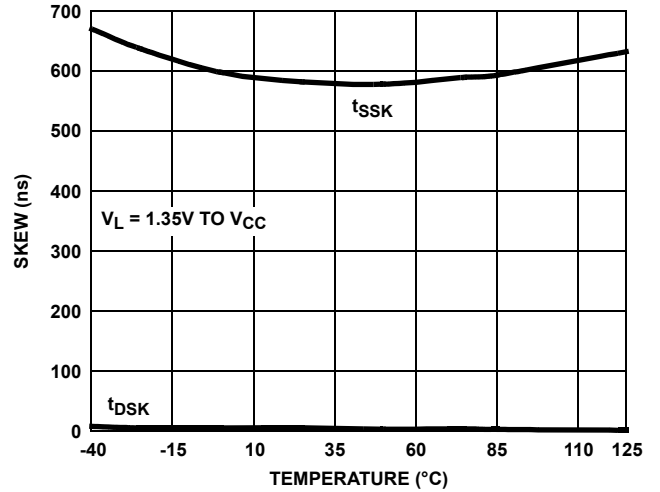

FIGURE 14. DRIVER SKEW vs TEMPERATURE (ISL3293E, ISL3296E)

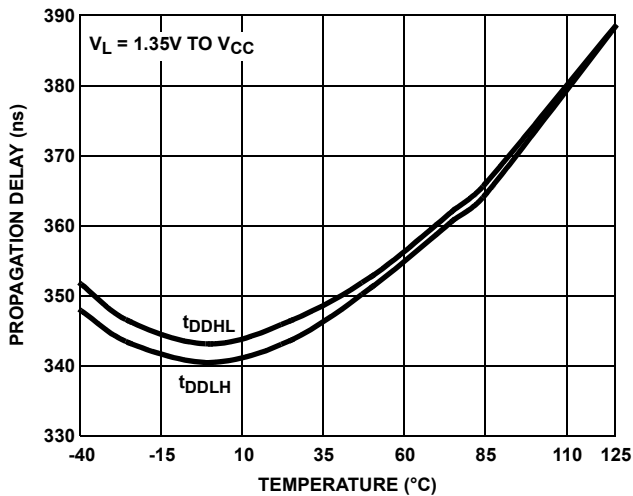

FIGURE 15. DRIVER DIFFERENTIAL PROPAGATION DELAY vs TEMPERATURE (ISL3294E, ISL3297E)

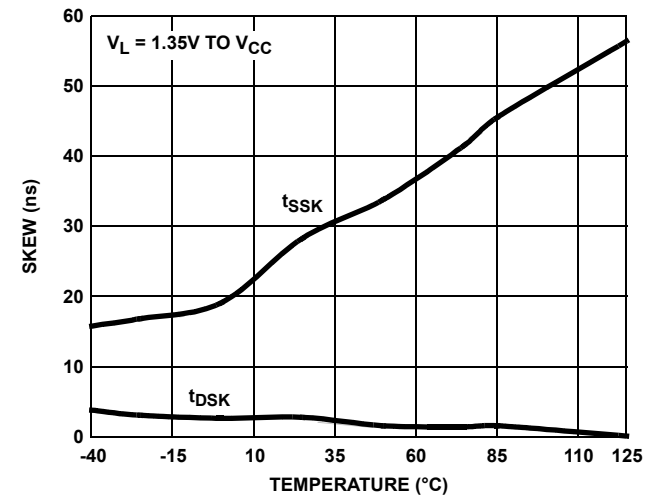

FIGURE 16. DRIVER SKEW vs TEMPERATURE (ISL3294E, ISL3297E)

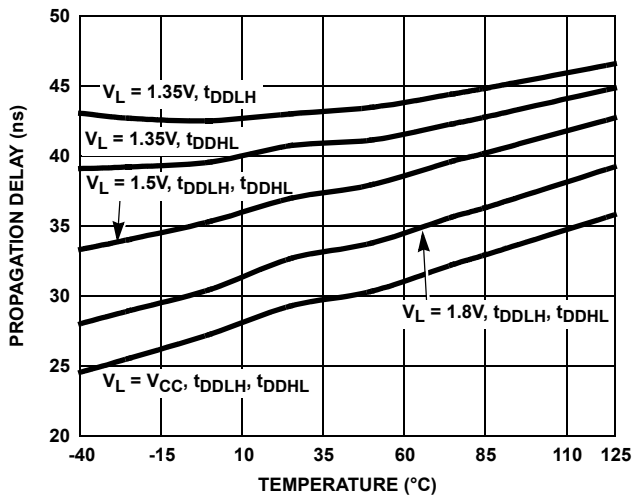

FIGURE 17. DRIVER DIFFERENTIAL PROPAGATION DELAY vs TEMPERATURE (ISL3295E, ISL3298E)

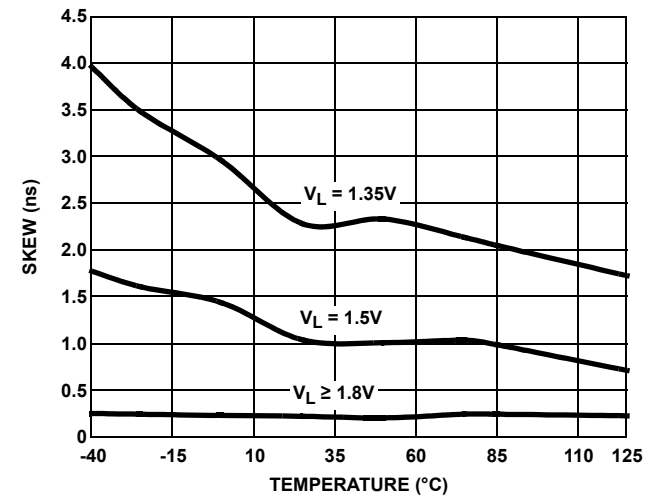

FIGURE 18. DRIVER DIFFERENTIAL SKEW vs TEMPERATURE (ISL3295E, ISL3298E)

Typical Performance Curves $V_{CC} = V_L = 3.3V$, $T_A = +25^\circ C$, unless otherwise specified. (Continued)

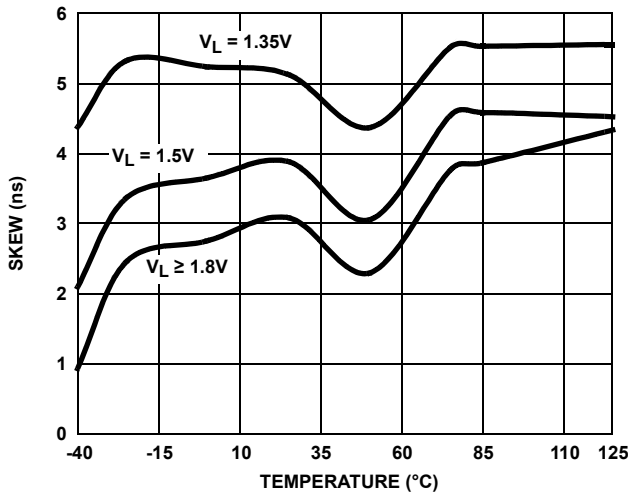

FIGURE 19. DRIVER SINGLE-ENDED SKEW vs TEMPERATURE (ISL3295E, ISL3298E)

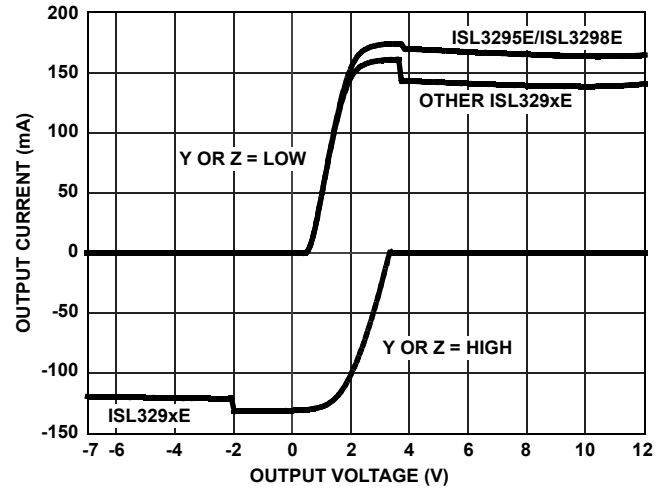

FIGURE 20. DRIVER OUTPUT CURRENT vs SHORT-CIRCUIT VOLTAGE

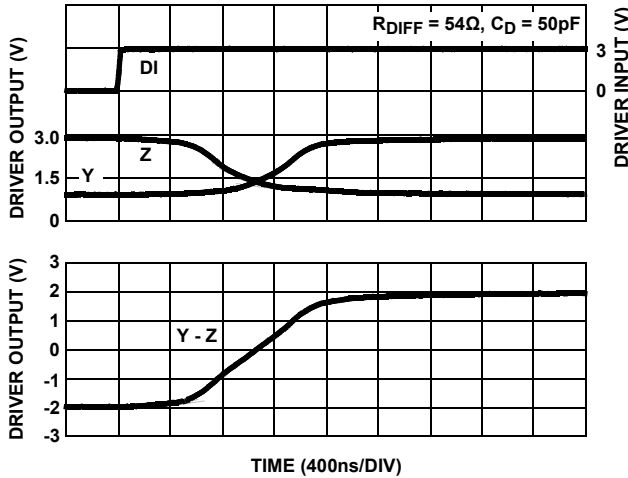

FIGURE 21. DRIVER WAVEFORMS, LOW-TO-HIGH (ISL3293E, ISL3296E)

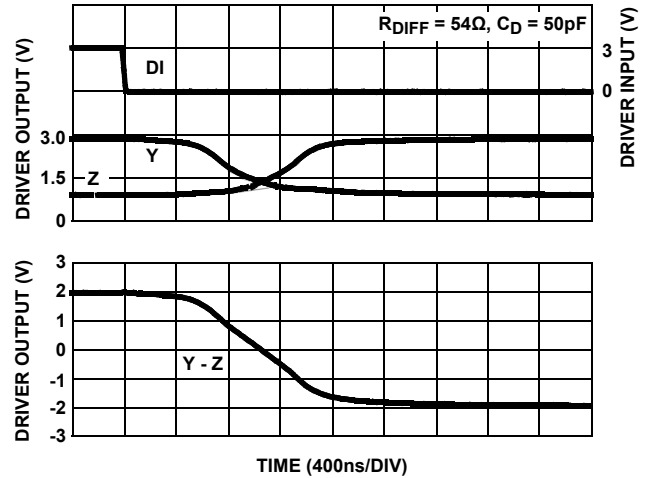

FIGURE 22. DRIVER WAVEFORMS, HIGH-TO-LOW (ISL3293E, ISL3296E)

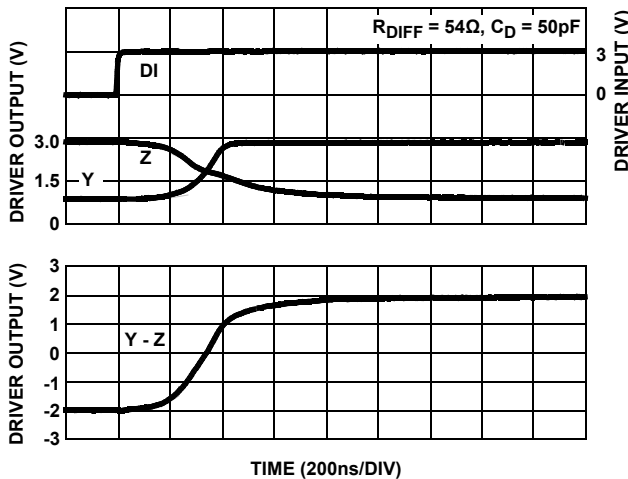

FIGURE 23. DRIVER WAVEFORMS, LOW-TO-HIGH (ISL3294E, ISL3297E)

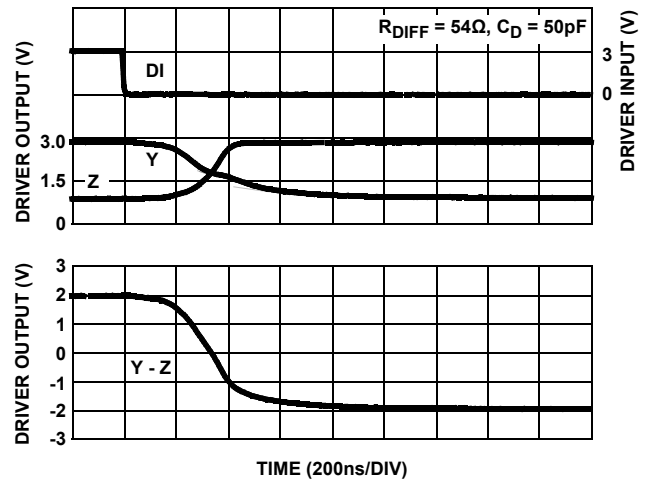

FIGURE 24. DRIVER WAVEFORMS, HIGH-TO-LOW (ISL3294E, ISL3297E)

Typical Performance Curves $V_{CC} = V_L = 3.3V, T_A = +25^\circ C$, unless otherwise specified. (Continued)

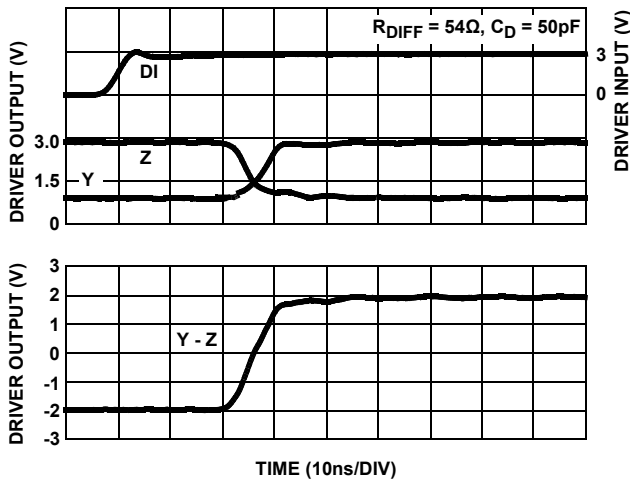

FIGURE 25. DRIVER WAVEFORMS, LOW-TO-HIGH (ISL3295E, ISL3298E)

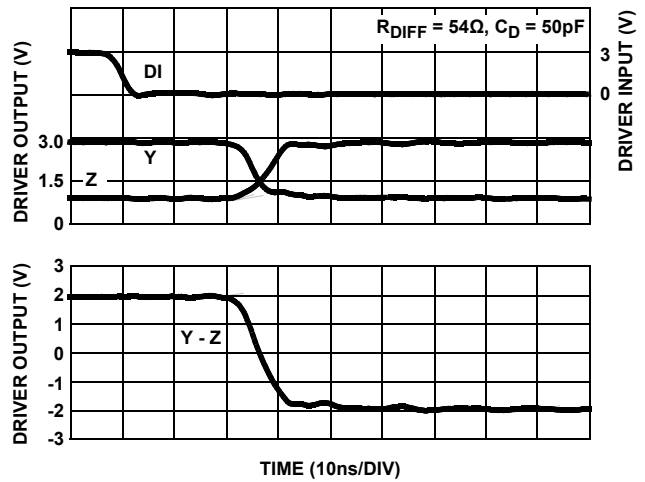

FIGURE 26. DRIVER WAVEFORMS, HIGH-TO-LOW (ISL3295E, ISL3298E)

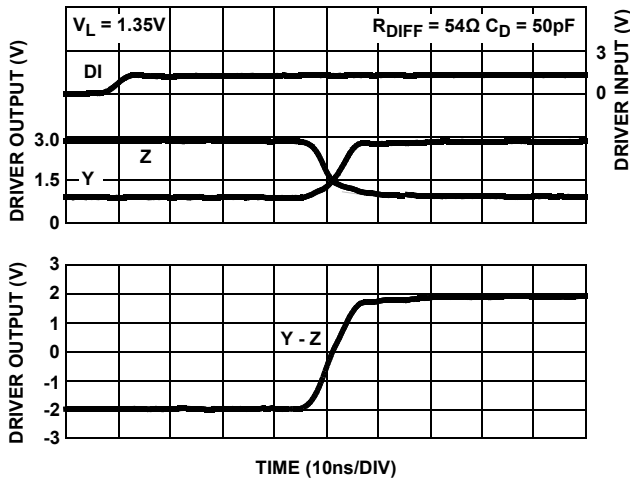

FIGURE 27. DRIVER WAVEFORMS, LOW-TO-HIGH (ISL3295E, ISL3298E)

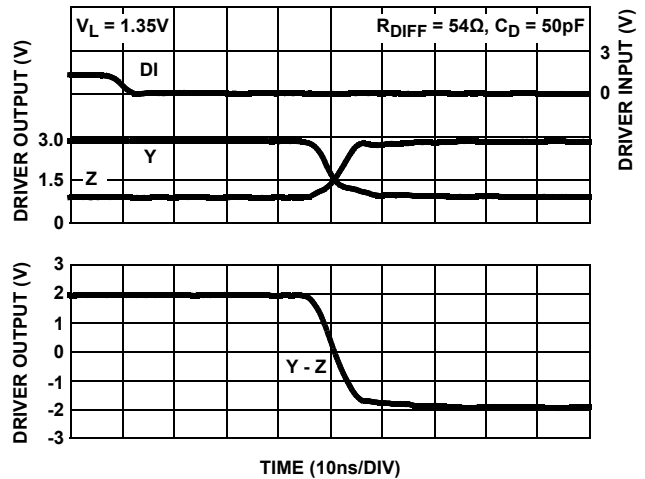

FIGURE 28. DRIVER WAVEFORMS, HIGH-TO-LOW (ISL3295E, ISL3298E)

Die Characteristics

SUBSTRATE AND TDFN THERMAL PAD POTENTIAL (POWERED UP):

GND

TRANSISTOR COUNT:

516

PROCESS:

Si Gate BiCMOS

Revision History

The revision history provided is for informational purposes only and is believed to be accurate, but not warranted. Please go to the web to make sure that you have the latest revision.

DATE	REVISION	CHANGE
September 25, 2015	FN6544.3	On page 1, table 1, for ISL3293E entry, added "Recommended replacement: ISL32613E" after "No longer available or supported". For ISL3294E entry, added "Recommended replacement: ISL32614E" after "No longer available or supported". On page 3, "Ordering Information" table, for ISL3293E entries (rows 1 and 2), added "Recommended replacement: ISL32613E" after "No longer available or supported". For ISL3294E entries (rows 3 and 4), added "Recommended replacement: ISL32614E" after "No longer available or supported".
July 27, 2015	FN6544.2	Table 1 Summary of Features on page 1, added "No longer available or supported" to ISL3293E, ISL3294E, ISL3296E, ISL3297E. Ordering Information table on page 3, added "No longer available or supported" to the following parts: ISL3293E and ISL3294E (1st 4 rows) and to ISL3296E and ISL3297E (rows 7-10). Electrical Spec table, added "(Parts no longer available or supported)" to DRIVER SWITCHING CHARACTERISTICS sections on page 6 (for parts ISL3293E, ISL3296E and ISL3294E, ISL3297E). POD on page 16, updated from ref 1 to rev 2. Changes since rev 1: Tiebar Note updated From: Tiebar shown (if present) is a non-functional feature. To: Tiebar shown (if present) is a non-functional feature and may be located on any of the 4 sides (or ends).
December 11, 2014	FN6544.1	Updated entire datasheet to Intersil new standard. Added text in several places to clarify that VL can be connected to Vcc. Updated PODs P6.064 and L8.2x3A to latest revisions with changes as follows: Updated to new POD format by removing table listing dimensions and moving dimensions onto drawing. Added Typical Recommended Land Pattern.
September 19, 2007	FN6544.0	Initial Release.

About Intersil

Intersil Corporation is a leading provider of innovative power management and precision analog solutions. The company's products address some of the largest markets within the industrial and infrastructure, mobile computing and high-end consumer markets.

For the most updated datasheet, application notes, related documentation and related parts, please see the respective product information page found at www.intersil.com.

You may report errors or suggestions for improving this datasheet by visiting www.intersil.com/ask.

Reliability reports are also available from our website at www.intersil.com/support

© Copyright Intersil Americas LLC 2007-2015. All Rights Reserved.
All trademarks and registered trademarks are the property of their respective owners.

For additional products, see www.intersil.com/en/products.html

Intersil products are manufactured, assembled and tested utilizing ISO9001 quality systems as noted in the quality certifications found at www.intersil.com/en/support/qualandreliability.html

Intersil products are sold by description only. Intersil may modify the circuit design and/or specifications of products at any time without notice, provided that such modification does not, in Intersil's sole judgment, affect the form, fit or function of the product. Accordingly, the reader is cautioned to verify that datasheets are current before placing orders. Information furnished by Intersil is believed to be accurate and reliable. However, no responsibility is assumed by Intersil or its subsidiaries for its use; nor for any infringements of patents or other rights of third parties which may result from its use. No license is granted by implication or otherwise under any patent or patent rights of Intersil or its subsidiaries.

For information regarding Intersil Corporation and its products, see www.intersil.com

Package Outline Drawing

P6.064

6 LEAD SMALL OUTLINE TRANSISTOR PLASTIC PACKAGE

Rev 4, 2/10

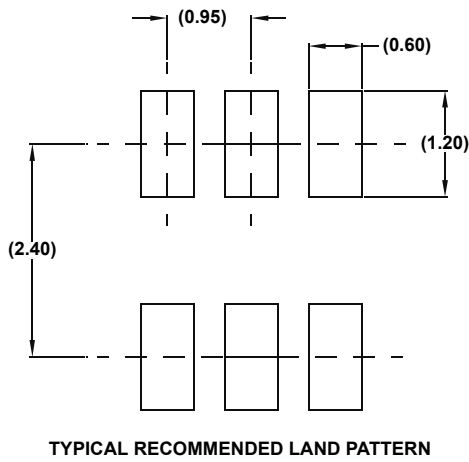
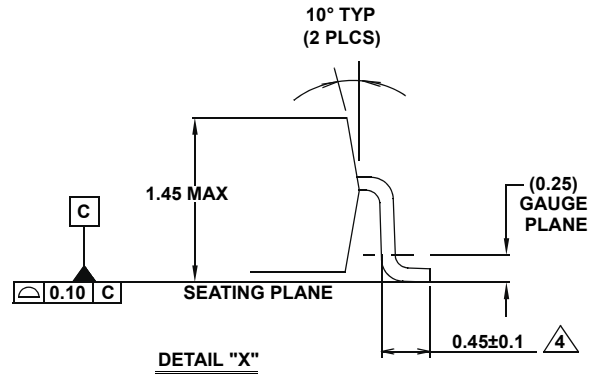
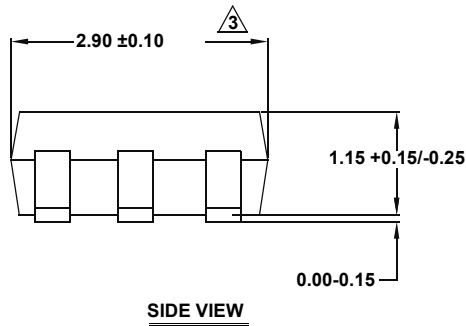
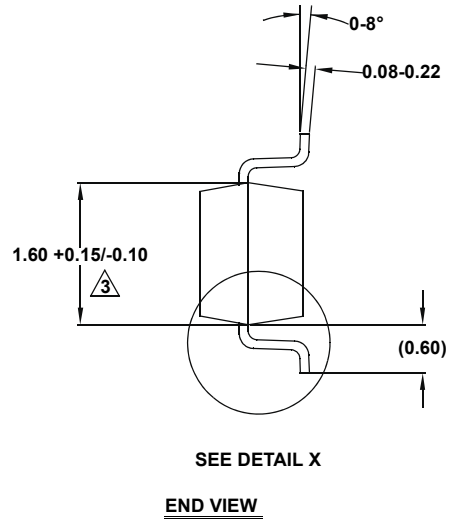
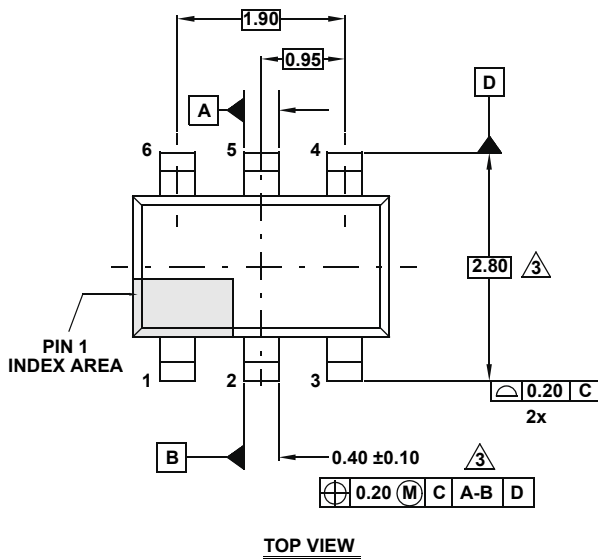

NOTES:

1. Dimensions are in millimeters.
Dimensions in () for Reference Only.
2. Dimensioning and tolerancing conform to ASME Y14.5M-1994.
3. Dimension is exclusive of mold flash, protrusions or gate burrs.
4. Foot length is measured at reference to gauge plane.
5. Package conforms to JEDEC MO-178AB.

Package Outline Drawing

L8.2x3A

8 LEAD THIN DUAL FLAT NO-LEAD PLASTIC PACKAGE WITH E-PAD

Rev 2, 05/15

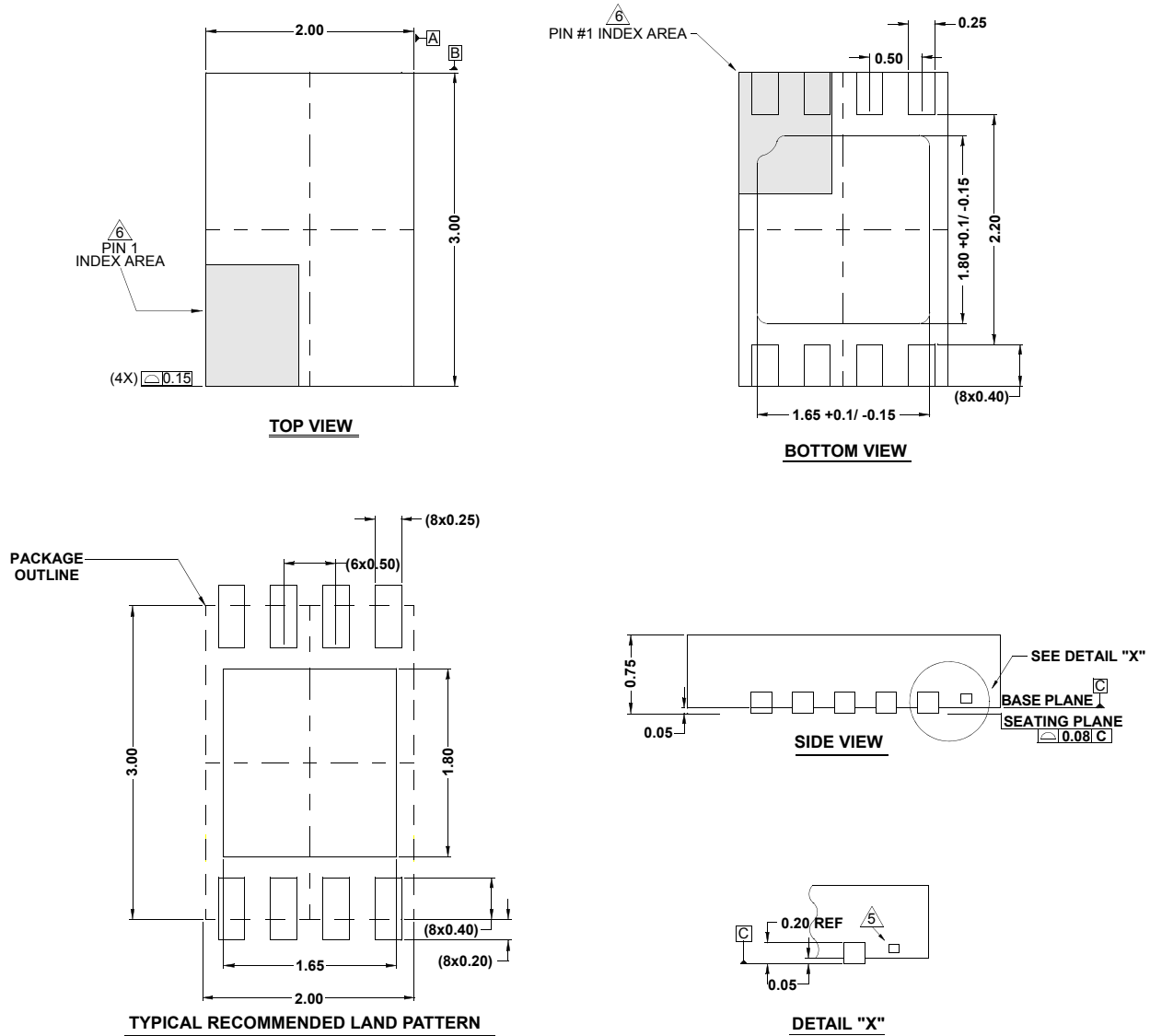

NOTES:

1. Dimensions are in millimeters.
Dimensions in () for Reference Only.
2. Dimensioning and tolerancing conform to ASME Y14.5m-1994.
3. Unless otherwise specified, tolerance : Decimal ± 0.05
4. Dimension b applies to the metallized terminal and is measured between 0.20mm and 0.32mm from the terminal tip.
5. Tiebar shown (if present) is a non-functional feature and may be located on any of the 4 sides (or ends).
6. The configuration of the pin #1 identifier is optional, but must be located within the zone indicated. The pin #1 identifier may be either a mold or mark feature.

Looking for pricing, stock, or lifecycle information?

Click below to explore more details on WIN SOURCE:

 [View ISL3294EFHZ-T on WIN SOURCE](#)

 [Intersil Information](#)

Optimize Your Supply Chain with WIN SOURCE Solutions

-  Global Sourcing Solution
-  Obsolete Management
-  Cost Control Management
-  Shortage Management
-  Alternative Solution
-  Excess Inventory Management