



ISD2560/75/90/120

**SINGLE-CHIP, MULTIPLE-MESSAGES,
VOICE RECORD/PLAYBACK DEVICE
60-, 75-, 90-, AND 120-SECOND DURATION**



1. GENERAL DESCRIPTION

Winbond's ISD2500 ChipCorder[®] Series provide high-quality, single-chip, Record/Playback solutions for 60- to 120-second messaging applications. The CMOS devices include an on-chip oscillator, microphone preamplifier, automatic gain control, antialiasing filter, smoothing filter, speaker amplifier, and high density multi-level storage array. In addition, the ISD2500 is microcontroller compatible, allowing complex messaging and addressing to be achieved. Recordings are stored into on-chip nonvolatile memory cells, providing zero-power message storage. This unique, single-chip solution is made possible through Winbond's patented multilevel storage technology. Voice and audio signals are stored directly into memory in their natural form, providing high-quality, solid-state voice reproduction.

2. FEATURES

- Easy-to-use single-chip, voice record/playback solution
- High-quality, natural voice/audio reproduction
- Single-chip with duration of 60, 75, 90, or 120 seconds.
- Manual switch or microcontroller compatible
- Playback can be edge- or level-activated
- Directly cascadable for longer durations
- Automatic power-down (push-button mode)
 - Standby current 1 μ A (typical)
- Zero-power message storage
 - Eliminates battery backup circuits
- Fully addressable to handle multiple messages
- 100-year message retention (typical)
- 100,000 record cycles (typical)
- On-chip clock source
- Programmer support for play-only applications
- Single +5 volt power supply
- Available in die form, PDIP, SOIC and TSOP packaging
- Packaged type: leaded and lead-free
- Temperature = die (0°C to +50°C) and package (0°C to +70°C)



3. BLOCK DIAGRAM

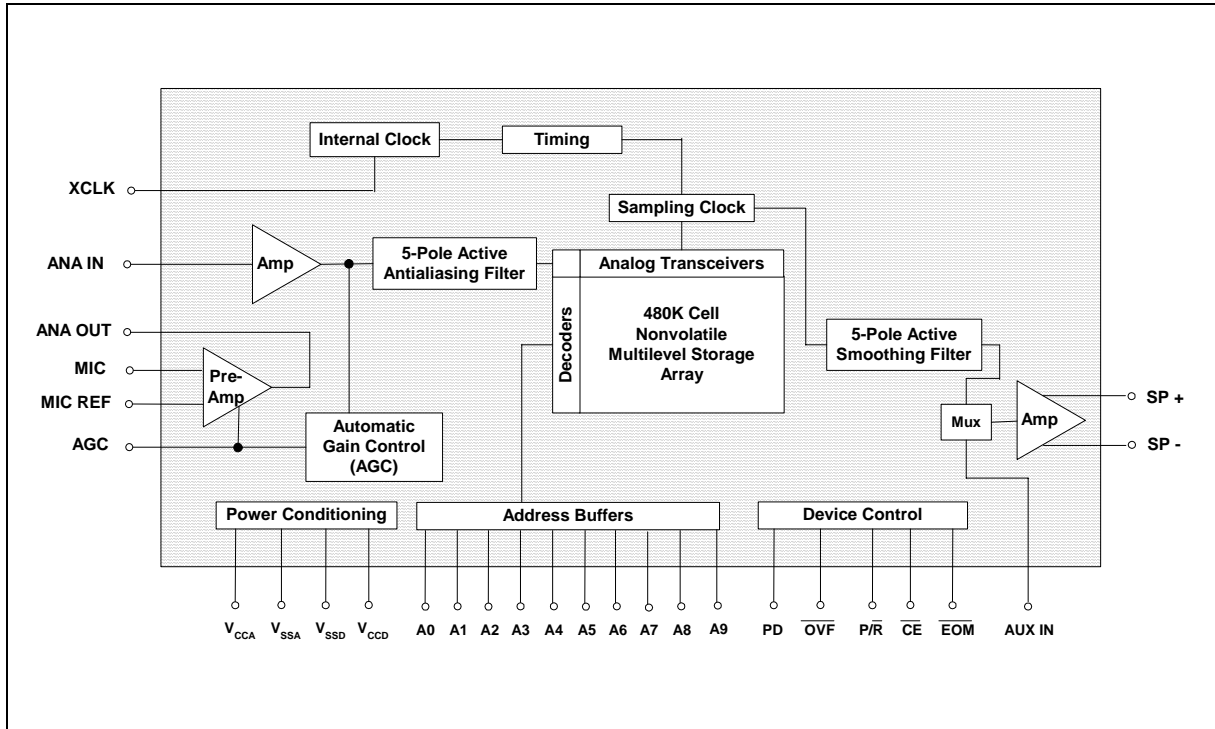



4. TABLE OF CONTENTS

1. GENERAL DESCRIPTION..... 2

2. FEATURES 2

3. BLOCK DIAGRAM..... 3

4. TABLE OF CONTENTS 4

5. PIN CONFIGURATION 5

6. PIN DESCRIPTION 6

7. FUNCTIONAL DESCRIPTION..... 10

 7.1. Detailed Description..... 10

 7.2. Operational Modes 11

 7.2.1. Operational Modes Description..... 12

8. TIMING DIAGRAMS 16

9. ABSOLUTE MAXIMUM RATINGS..... 19

 9.1 Operating Conditions 20

10. ELECTRICAL CHARACTERISTICS 21

 10.1. Parameters For Packaged Parts 21

 10.1.1. Typical Parameter Variation with Voltage and Temperature (Packaged Parts)..... 24

 10.2. Parameters For Die 25

 10.2.1. Typical Parameter Variation with Voltage and Temperature (Die) 28

 10.3. Parameters For Push-Button Mode..... 29

11. TYPICAL APPLICATION CIRCUIT 30

12. PACKAGE DRAWING AND DIMENSIONS 35

 12.1. 28-Lead 300-Mil Plastic Small Outline IC (SOIC)..... 35

 12.2. 28-Lead 600-Mil Plastic Dual Inline Package (PDIP)..... 36

 12.3. 28-Lead 8x13.4mm Plastic Thin Small Outline Package (TSOP) Type 1 37

 12.4. 28-Lead 8x13.4mm Plastic Thin Small Outline Package (TSOP) Type 1 - IQC 38

 12.5. ISD2560/75/95/120 Product Bonding Physical Layout (Die) ^[1] 39

13. ORDERING INFORMATION 41

14. VERSION HISTORY 42

ISD2560/75/90/120



5. PIN CONFIGURATION

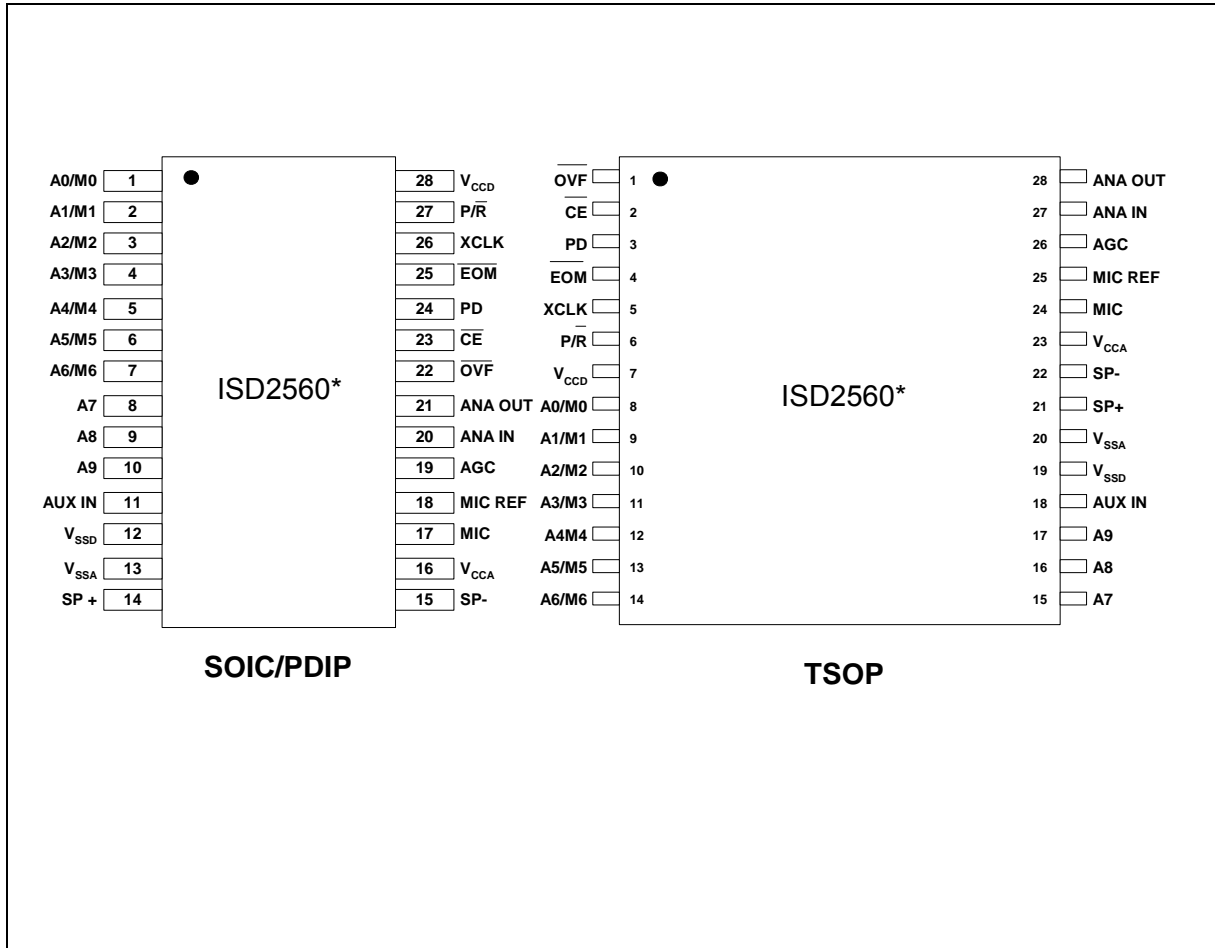

* Same pinouts for ISD2575 / 2590 / 25120 products



6. PIN DESCRIPTION

PIN NAME	PIN NO.		FUNCTION
	SOIC/ PDIP	TSOP	
Ax/Mx	1-10/ 1-7	8-17/ 8-14	<p>Address/Mode Inputs: The Address/Mode Inputs have two functions depending on the level of the two Most Significant Bits (MSB) of the address pins (A8 and A9).</p> <p>If either or both of the two MSBs are LOW, the inputs are all interpreted as address bits and are used as the start address for the current record or playback cycle. The address pins are inputs only and do not output any internal address information during the operation. Address inputs are latched by the falling edge of \overline{CE}.</p> <p>If both MSBs are HIGH, the Address/Mode inputs are interpreted as Mode bits according to the Operational Mode table on page 12. There are six operational modes (M0...M6) available as indicated in the table. It is possible to use multiple operational modes simultaneously. Operational Modes are sampled on each falling edge of \overline{CE}, and thus Operational Modes and direct addressing are mutually exclusive.</p>
AUX IN	11	18	<p>Auxiliary Input: The Auxiliary Input is multiplexed through to the output amplifier and speaker output pins when \overline{CE} is HIGH, P/R is HIGH, and playback is currently not active or if the device is in playback overflow. When cascading multiple ISD2500 devices, the AUX IN pin is used to connect a playback signal from a following device to the previous output speaker drivers. For noise considerations, it is suggested that the auxiliary input not be driven when the storage array is active.</p>
V _{SSA} , V _{SSD}	13, 12	20, 19	<p>Ground: The ISD2500 series of devices utilizes separate analog and digital ground busses. These pins should be connected separately through a low-impedance path to power supply ground.</p>
SP+/SP-	14/15	21/22	<p>Speaker Outputs: All devices in the ISD2500 series include an on-chip differential speaker driver, capable of driving 50 mW into 16 Ω from AUX IN (12.2mW from memory).</p> <p>^[1] The speaker outputs are held at V_{SSA} levels during record and power down. It is therefore not possible to parallel speaker outputs of multiple ISD2500 devices or the outputs of other speaker drivers.</p> <p>^[2] A single-end output may be used (including a coupling capacitor between the SP pin and the speaker). These outputs may be used individually with the output signal taken from either pin. However, the use of single-end output results in a 1 to 4 reduction in its output power.</p>

^[1] Connection of speaker outputs in parallel may cause damage to the device.

^[2] Never ground or drive an unused speaker output.



PIN NAME	PIN NO.		FUNCTION
	SOIC/ PDIP	TSOP	
V _{CCA} , V _{CCD}	16, 28	23, 7	Supply Voltage: To minimize noise, the analog and digital circuits in the ISD2500 series devices use separate power busses. These voltage busses are brought out to separate pins and should be tied together as close to the supply as possible. In addition, these supplies should be decoupled as close to the package as possible.
MIC	17	24	Microphone: The microphone pin transfers input signal to the on-chip preamplifier. A built-in Automatic Gain Control (AGC) circuit controls the gain of this preamplifier from -15 to 24dB. An external microphone should be AC coupled to this pin via a series capacitor. The capacitor value, together with the internal 10 KΩ resistance on this pin, determines the low-frequency cutoff for the ISD2500 series passband. See Winbond's Application Information for additional information on low-frequency cutoff calculation.
MIC REF	18	25	Microphone Reference: The MIC REF input is the inverting input to the microphone preamplifier. This provides a noise-canceling or common-mode rejection input to the device when connected to a differential microphone.
AGC	19	26	Automatic Gain Control: The AGC dynamically adjusts the gain of the preamplifier to compensate for the wide range of microphone input levels. The AGC allows the full range of whispers to loud sounds to be recorded with minimal distortion. The "attack" time is determined by the time constant of a 5 KΩ internal resistance and an external capacitor (C2 on the schematic of Figure 5 in section 11) connected from the AGC pin to V _{SSA} analog ground. The "release" time is determined by the time constant of an external resistor (R2) and an external capacitor (C2) connected in parallel between the AGC pin and V _{SSA} analog ground. Nominal values of 470 KΩ and 4.7 μF give satisfactory results in most cases.
ANA IN	20	27	Analog Input: The analog input transfers analog signal to the chip for recording. For microphone inputs, the ANA OUT pin should be connected via an external capacitor to the ANA IN pin. This capacitor value, together with the 3.0 KΩ input impedance of ANA IN, is selected to give additional cutoff at the low-frequency end of the voice passband. If the desired input is derived from a source other than a microphone, the signal can be fed, capacitively coupled, into the ANA IN pin directly.
ANA OUT	21	28	Analog Output: This pin provides the preamplifier output to the user. The voltage gain of the preamplifier is determined by the voltage level at the AGC pin.



PIN NAME	PIN NO.		FUNCTION
	SOIC/ PDIP	TSOP	
$\overline{\text{OVF}}$	22	1	Overflow: This signal pulses LOW at the end of memory array, indicating the device has been filled and the message has overflowed. The $\overline{\text{OVF}}$ output then follows the $\overline{\text{CE}}$ input until a PD pulse has reset the device. This pin can be used to cascade several ISD2500 devices together to increase record/playback durations.
$\overline{\text{CE}}$	23	2	Chip Enable: The $\overline{\text{CE}}$ input pin is taken LOW to enable all playback and record operations. The address pins and playback/record pin ($\overline{\text{P/R}}$) are latched by the falling edge of $\overline{\text{CE}}$. $\overline{\text{CE}}$ has additional functionality in the M6 (Push-Button) Operational Mode as described in the Operational Mode section.
PD	24	3	Power Down: When neither record nor playback operation, the PD pin should be pulled HIGH to place the part in standby mode (see I_{SB} specification). When overflow ($\overline{\text{OVF}}$) pulses LOW for an overflow condition, PD should be brought HIGH to reset the address pointer back to the beginning of the memory array. The PD pin has additional functionality in the M6 (Push-Button) Operation Mode as described in the Operational Mode section.
$\overline{\text{EOM}}$	25	4	End-Of-Message: A nonvolatile marker is automatically inserted at the end of each recorded message. It remains there until the message is recorded over. The $\overline{\text{EOM}}$ output pulses LOW for a period of T_{EOM} at the end of each message. In addition, the ISD2500 series has an internal V_{CC} detect circuit to maintain message integrity should V_{CC} fall below 3.5V. In this case, $\overline{\text{EOM}}$ goes LOW and the device is fixed in Playback-only mode. When the device is configured in Operational Mode M6 (Push-Button Mode), this pin provides an active-HIGH signal, indicating the device is currently recording or playing. This signal can conveniently drive an LED for visual indicator of a record or playback operation in process.



PIN NAME	PIN NO.		FUNCTION															
	SOIC/ PDIP	TSOP																
XCLK	26	5	<p>External Clock: The external clock input has an internal pull-down device. The device is configured at the factory with an internal sampling clock frequency centered to ± 1 percent of specification. The frequency is then maintained to a variation of ± 2.25 percent over the entire commercial temperature and operating voltage ranges. If greater precision is required, the device can be clocked through the XCLK pin as follows:</p> <table border="1"> <thead> <tr> <th>Part Number</th> <th>Sample Rate</th> <th>Required Clock</th> </tr> </thead> <tbody> <tr> <td>ISD2560</td> <td>8.0 kHz</td> <td>1024 kHz</td> </tr> <tr> <td>ISD2575</td> <td>6.4 kHz</td> <td>819.2 kHz</td> </tr> <tr> <td>ISD2590</td> <td>5.3 kHz</td> <td>682.7 kHz</td> </tr> <tr> <td>ISD25120</td> <td>4.0 kHz</td> <td>512 kHz</td> </tr> </tbody> </table> <p>These recommended clock rates should not be varied because the antialiasing and smoothing filters are fixed, and aliasing problems can occur if the sample rate differs from the one recommended. The duty cycle on the input clock is not critical, as the clock is immediately divided by two. If the XCLK is not used, this input must be connected to ground.</p>	Part Number	Sample Rate	Required Clock	ISD2560	8.0 kHz	1024 kHz	ISD2575	6.4 kHz	819.2 kHz	ISD2590	5.3 kHz	682.7 kHz	ISD25120	4.0 kHz	512 kHz
Part Number	Sample Rate	Required Clock																
ISD2560	8.0 kHz	1024 kHz																
ISD2575	6.4 kHz	819.2 kHz																
ISD2590	5.3 kHz	682.7 kHz																
ISD25120	4.0 kHz	512 kHz																
P/R	27	6	<p>Playback/Record: The P/R input pin is latched by the falling edge of the \overline{CE} pin. A HIGH level selects a playback cycle while a LOW level selects a record cycle. For a record cycle, the address pins provide the starting address and recording continues until PD or \overline{CE} is pulled HIGH or an overflow is detected (i.e. the chip is full). When a record cycle is terminated by pulling PD or \overline{CE} HIGH, then End-Of-Message (EOM) marker is stored at the current address in memory. For a playback cycle, the address inputs provide the starting address and the device will play until an EOM marker is encountered. The device can continue to pass an EOM marker if \overline{CE} is held LOW in address mode, or in an Operational Mode. (See Operational Modes section)</p>															



7. FUNCTIONAL DESCRIPTION

7.1. DETAILED DESCRIPTION

Speech/Sound Quality

The Winbond's ISD2500 series includes devices offered at 4.0, 5.3, 6.4, and 8.0 kHz sampling frequencies, allowing the user a choice of speech quality options. Increasing the duration within a product series decreases the sampling frequency and bandwidth, which affects the sound quality. Please refer to the ISD2560/75/90/120 Product Summary table below to compare the duration, sampling frequency and filter pass band.

The speech samples are stored directly into the on-chip nonvolatile memory without any digitization and compression associated like other solutions. Direct analog storage provides a very true, natural sounding reproduction of voice, music, tones, and sound effects not available with most solid state digital solutions.

Duration

To meet various system requirements, the ISD2560/75/90/120 products offer single-chip solutions at 60, 75, 90, and 120 seconds. Parts may also be cascaded together for longer durations.

TABLE 1: ISD2560/75/90/120 PRODUCT SUMMARY

Part Number	Duration (Seconds)	Input Sample Rate (kHz)	Typical Filter Pass Band * (kHz)
ISD2560	60	8.0	3.4
ISD2575	75	6.4	2.7
ISD2590	90	5.3	2.3
ISD25120	120	4.0	1.7

* 3db roll-off point

EEPROM Storage

One of the benefits of Winbond's ChipCorder[®] technology is the use of on-chip nonvolatile memory, providing zero-power message storage. The message is retained for up to 100 years typically without power. In addition, the device can be re-recorded typically over 100,000 times.

Microcontroller Interface

In addition to its simplicity and ease of use, the ISD2500 series includes all the interfaces necessary for microcontroller-driven applications. The address and control lines can be interfaced to a microcontroller and manipulated to perform a variety of tasks, including message assembly, message concatenation, predefined fixed message segmentation, and message management.



Programming

The ISD2500 series is also ideal for playback-only applications, where single or multiple messages are referenced through buttons, switches, or a microcontroller. Once the desired message configuration is created, duplicates can easily be generated via a gang programmer.

7.2. OPERATIONAL MODES

The ISD2500 series is designed with several built-in Operational Modes that provide maximum functionality with minimum external components. These modes are described in details as below. The Operational Modes are accessed via the address pins and mapped beyond the normal message address range. When the two Most Significant Bits (MSB), A8 and A9, are HIGH, the remaining address signals are interpreted as mode bits and not as address bits. Therefore, Operational Modes and direct addressing are not compatible and cannot be used simultaneously.

There are two important considerations for using Operational Modes. First, all operations begin initially at address 0 of its memory. Later operations can begin at other address locations, depending on the Operational Mode(s) chosen. In addition, the address pointer is reset to 0 when the device is changed from record to playback, playback to record (except M6 mode), or when a Power-Down cycle is executed.

Second, Operational Modes are executed when \overline{CE} goes LOW. This Operational Mode remains in effect until the next LOW-going \overline{CE} signal, at which point the current mode(s) are sampled and executed.

TABLE 2: OPERATIONAL MODES

Mode ^[1]	Function	Typical Use	Jointly Compatible ^[2]
M0	Message cueing	Fast-forward through messages	M4, M5, M6
M1	Delete \overline{EOM} markers	Position \overline{EOM} marker at the end of the last message	M3, M4, M5, M6
M2	Not applicable	Reserved	N/A
M3	Looping	Continuous playback from Address 0	M1, M5, M6
M4	Consecutive addressing	Record/playback multiple consecutive messages	M0, M1, M5
M5	\overline{CE} level-activated	Allows message pausing	M0, M1, M3, M4
M6	Push-button control	Simplified device interface	M0, M1, M3

^[1] Besides mode pin needed to be "1", A8 and A9 pin are also required to be "1" in order to enter into the related operational mode.

^[2] Indicates additional Operational Modes which can be used simultaneously with the given mode.



7.2.1. Operational Modes Description

The Operational Modes can be used in conjunction with a microcontroller, or they can be hardwired to provide the desired system operation.

M0 – Message Cueing

Message Cueing allows the user to skip through messages, without knowing the actual physical addresses of each message. Each $\overline{\text{CE}}$ LOW pulse causes the internal address pointer to skip to the next message. This mode is used for playback only, and is typically used with the M4 Operational Mode.

M1 – Delete $\overline{\text{EOM}}$ Markers

The M1 Operational Mode allows sequentially recorded messages to be combined into a single message with only one $\overline{\text{EOM}}$ marker set at the end of the final message. When this Operational Mode is configured, messages recorded sequentially are played back as one continuous message.

M2 – Unused

When Operational Modes are selected, the M2 pin should be LOW.

M3 – Message Looping

The M3 Operational Mode allows for the automatic, continuously repeated playback of the message located at the beginning of the address space. A message can completely fill the ISD2500 device and will loop from beginning to end without $\overline{\text{OVF}}$ going LOW.

M4 – Consecutive Addressing

During normal operation, the address pointer will reset when a message is played through an $\overline{\text{EOM}}$ marker. The M4 Operational Mode inhibits the address pointer reset on $\overline{\text{EOM}}$, allowing messages to be played back consecutively.

M5 - $\overline{\text{CE}}$ -Level Activated

The default mode for ISD2500 devices is for $\overline{\text{CE}}$ to be edge-activated on playback and level-activated on record. The M5 Operational Mode causes the $\overline{\text{CE}}$ pin to be interpreted as level-activated as opposed to edge-activated during playback. This is especially useful for terminating playback operations using the $\overline{\text{CE}}$ signal. In this mode, $\overline{\text{CE}}$ LOW begins a playback cycle, at the beginning of the device memory. The playback cycle continues as long as $\overline{\text{CE}}$ is held LOW. When $\overline{\text{CE}}$ goes HIGH, playback will immediately end. A new $\overline{\text{CE}}$ LOW will restart the message from the beginning unless M4 is also HIGH.



M6 – Push-Button Mode

The ISD2500 series contain a Push-Button Operational Mode. The Push-Button Mode is used primarily in very low-cost applications and is designed to minimize external circuitry and components, thereby reducing system cost. In order to configure the device in Push-Button Operational Mode, the two most significant address bits must be HIGH, and the M6 mode pin must also be HIGH. A device in this mode always powers down at the end of each playback or record cycle after \overline{CE} goes HIGH.

When this operational mode is implemented, three of the pins on the device have alternate functionality as described in the table below.

TABLE 3: ALTERNATE FUNCTIONALITY IN PINS

Pin Name	Alternate Functionality in Push-Button Mode
\overline{CE}	Start/Pause Push-Button (LOW pulse-activated)
PD	Stop/Reset Push-Button (HIGH pulse-activated)
\overline{EOM}	Active-HIGH Run Indicator

\overline{CE} (START/PAUSE)

In Push-Button Operational Mode, \overline{CE} acts as a LOW-going pulse-activated START/PAUSE signal. If no operation is currently in progress, a LOW-going pulse on this signal will initiate a playback or record cycle according to the level on the P/ \overline{R} pin. A subsequent pulse on the \overline{CE} pin, before an \overline{EOM} is reached in playback or an overflow condition occurs, will pause the current operation, and the address counter is not reset. Another \overline{CE} pulse will cause the device to continue the operation from the place where it is paused.

PD (STOP/RESET)

In Push-Button Operational Mode, PD acts as a HIGH-going pulse-activated STOP/RESET signal. When a playback or record cycle is in progress and a HIGH-going pulse is observed on PD, the current cycle is terminated and the address pointer is reset to address 0, the beginning of the message space.

\overline{EOM} (RUN)

In Push-Button Operational Mode, \overline{EOM} becomes an active-HIGH RUN signal which can be used to drive an LED or other external device. It is HIGH whenever a record or playback operation is in progress.

Recording in Push-Button Mode

1. The PD pin should be LOW, usually using a pull-down resistor.



2. The $\overline{P/R}$ pin is taken LOW.
3. The \overline{CE} pin is pulsed LOW. Recording starts, \overline{EOM} goes HIGH to indicate an operation in progress.
4. When the \overline{CE} pin is pulsed LOW. Recording pauses, \overline{EOM} goes back LOW. The internal address pointers are not cleared, but the \overline{EOM} marker is stored in memory to indicate as the message end. The $\overline{P/R}$ pin may be taken HIGH at this time. Any subsequent \overline{CE} would start a playback at address 0.
5. The \overline{CE} pin is pulsed LOW. Recording starts at the next address after the previous set \overline{EOM} marker. \overline{EOM} goes back HIGH.^[3]
6. When the recording sequences are finished, the final \overline{CE} pulse LOW will end the last record cycle, leaving a set \overline{EOM} marker at the message end. Recording may also be terminated by a HIGH level on PD, which will leave a set \overline{EOM} marker.

Playback in Push-Button Mode

1. The PD pin should be LOW.
2. The $\overline{P/R}$ pin is taken HIGH.
3. The \overline{CE} pin is pulsed LOW. Playback starts, \overline{EOM} goes HIGH to indicate an operation in progress.
4. If the \overline{CE} pin is pulsed LOW or an \overline{EOM} marker is encountered during an operation, the part will pause. The internal address pointers are not cleared, and \overline{EOM} goes back LOW. The $\overline{P/R}$ pin may be changed at this time. A subsequent record operation would not reset the address pointers and the recording would begin where playback ended.
5. \overline{CE} is again pulsed LOW. Playback starts where it left off, with \overline{EOM} going HIGH to indicate an operation in progress.
6. Playback continues as in steps 4 and 5 until PD is pulsed HIGH or overflow occurs.
7. If in overflow, pulling \overline{CE} LOW will reset the address pointer and start playback from the beginning. After a PD pulse, the part is reset to address 0.

Note: Push-Button Mode can be used in conjunction with modes M0, M1, and M3.

^[3] If the M1 Operational Mode pin is also HIGH, the just previously written \overline{EOM} bit is erased, and recording starts at that address.

ISD2560/75/90/120



Good Audio Design Practices

Winbond products are very high-quality single-chip voice recording and playback systems. To ensure the highest quality voice reproduction, it is important that good audio design practices on layout and power supply decoupling be followed. See Application Information or below links for details.

Good Audio Design Practices

http://www.winbond-usa.com/products/isd_products/chipcorder/applicationinfo/apin11.pdf

Single-Chip Board Layout Diagrams

http://www.winbond-usa.com/products/isd_products/chipcorder/applicationinfo/apin12.pdf



8. TIMING DIAGRAMS

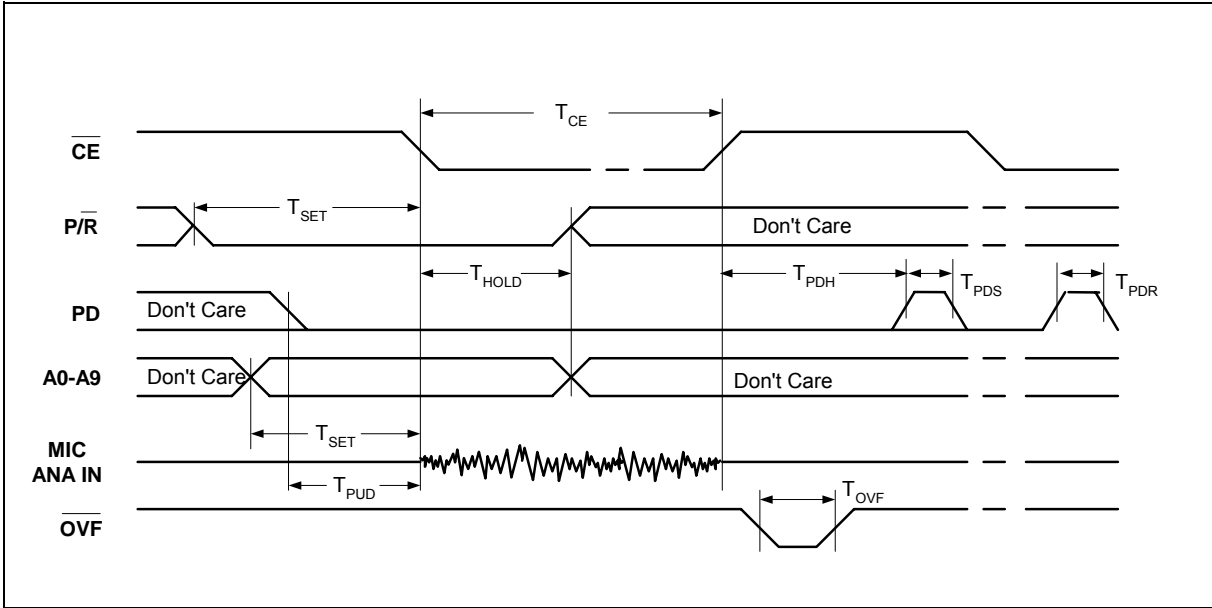

FIGURE 1: RECORD

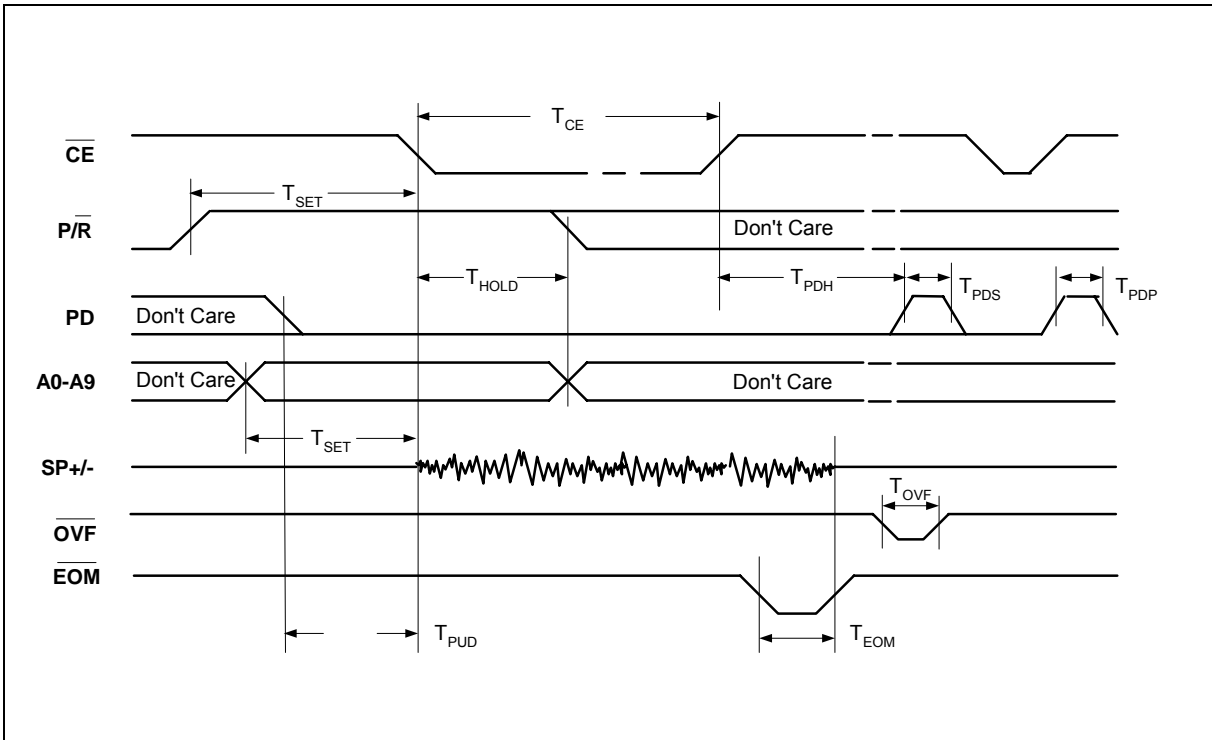

FIGURE 2: PLAYBACK

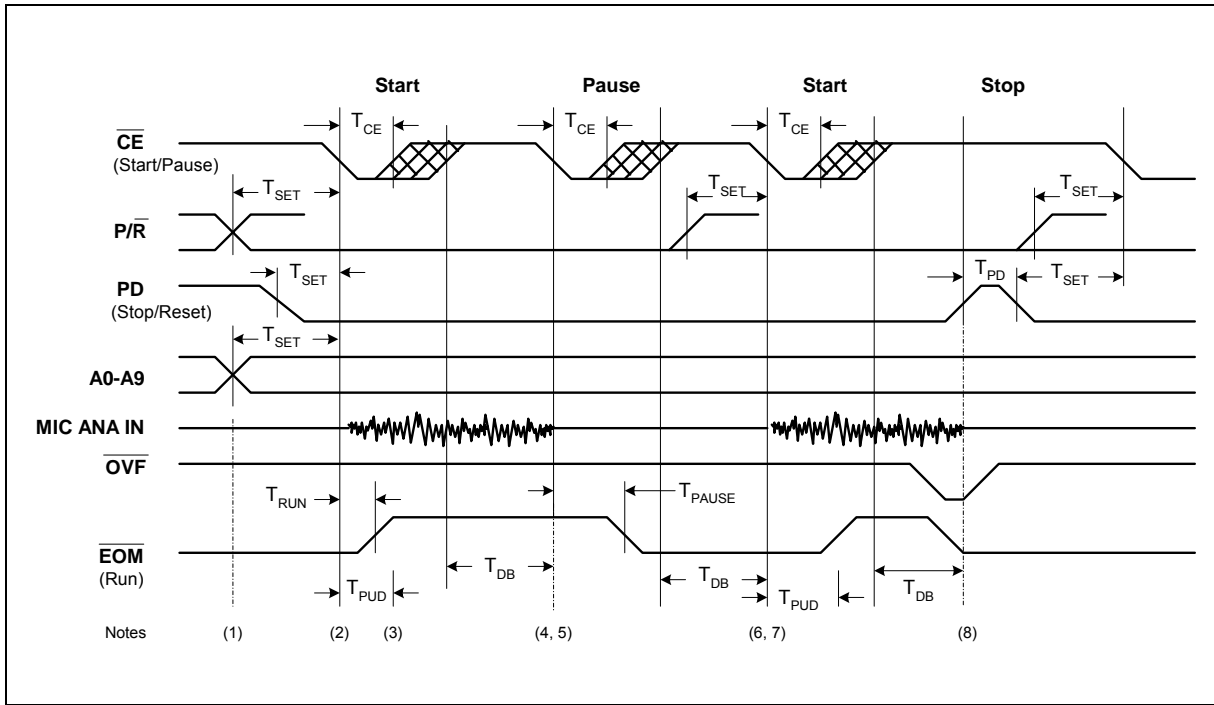

FIGURE 3: PUSH-BUTTON MODE RECORD

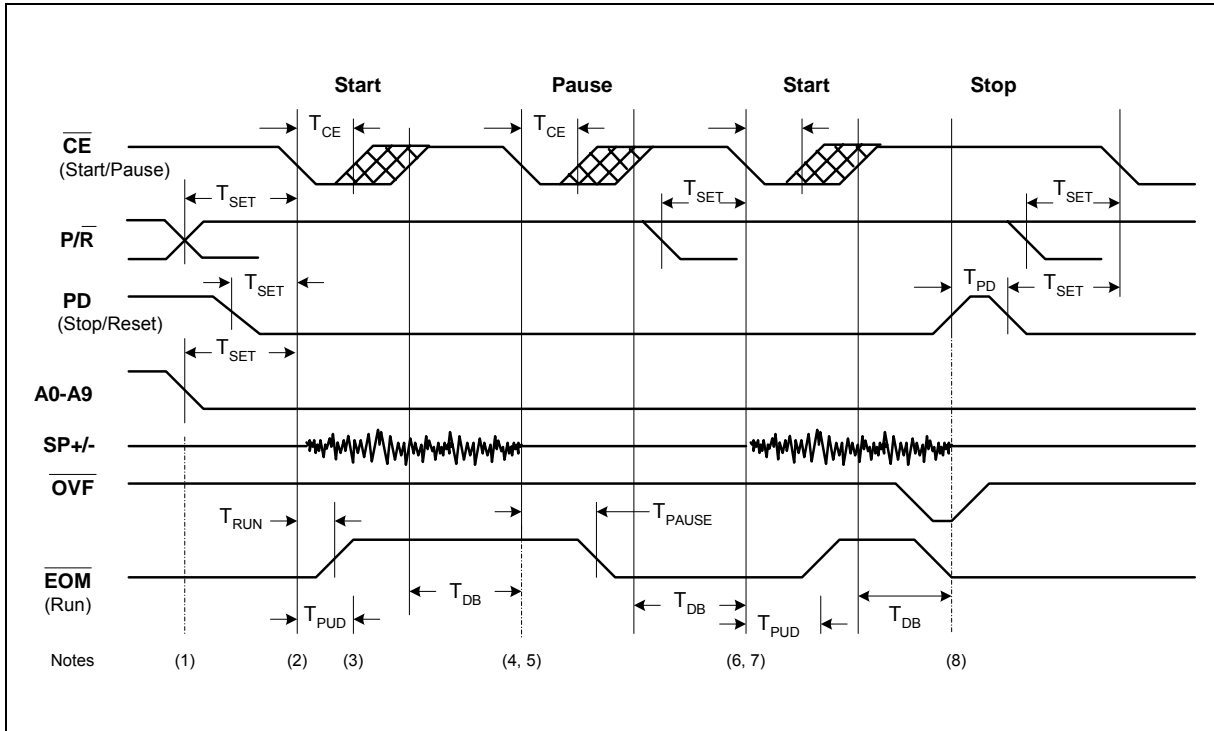

FIGURE 4: PUSH-BUTTON MODE PLAYBACK



Notes for Push-Button modes:

1. A9, A8, and A6 = 1 for push-button operation.
2. The first $\overline{\text{CE}}$ LOW pulse performs a start function.
3. The part will begin to play or record after a power-up delay T_{PUD} .
4. The part must have $\overline{\text{CE}}$ HIGH for a debounce period T_{DB} before it will recognize another falling edge of $\overline{\text{CE}}$ and pause.
5. The second $\overline{\text{CE}}$ LOW pulse, and every even pulse thereafter, performs a Pause function.
6. Again, the part must have $\overline{\text{CE}}$ HIGH for a debounce period T_{DB} before it will recognize another falling edge of $\overline{\text{CE}}$, which would restart an operation. In addition, the part will not do an internal power down until $\overline{\text{CE}}$ is HIGH for the T_{DB} time.
7. The third $\overline{\text{CE}}$ LOW pulse, and every odd pulse thereafter, performs a Resume function.
8. At any time, a HIGH level on PD will stop the current function, reset the address counter, and power down the device.



9. ABSOLUTE MAXIMUM RATINGS

TABLE 4: ABSOLUTE MAXIMUM RATINGS (DIE)

CONDITION	VALUE
Junction temperature	150°C
Storage temperature range	-65°C to +150°C
Voltage applied to any pad	(V _{SS} -0.3V) to (V _{CC} +0.3V)
Voltage applied to any pad (Input current limited to ±20mA)	(V _{SS} -1.0V) to (V _{CC} +1.0V)
V _{CC} - V _{SS}	-0.3V to +7.0V

TABLE 5: ABSOLUTE MAXIMUM RATINGS (PACKAGED PARTS)

CONDITION	VALUE
Junction temperature	150°C
Storage temperature range	-65°C to +150°C
Voltage applied to any pin	(V _{SS} -0.3V) to (V _{CC} +0.3V)
Voltage applied to any pin (Input current limited to ±20 mA)	(V _{SS} -1.0V) to (V _{CC} +1.0V)
Lead temperature (Soldering – 10sec)	300°C
V _{CC} - V _{SS}	-0.3V to +7.0V

Note: Stresses above those listed may cause permanent damage to the device. Exposure to the absolute maximum ratings may affect device reliability and performance. Functional operation is not implied at these conditions.



9.1 OPERATING CONDITIONS

TABLE 6: OPERATING CONDITIONS (DIE)

CONDITION	VALUE
Commercial operating temperature range	0°C to +50°C
Supply voltage (V_{CC}) ^[1]	+4.5V to +6.5V
Ground voltage (V_{SS}) ^[2]	0V

TABLE 7: OPERATING CONDITIONS (PACKAGED PARTS)

CONDITION	VALUE
Commercial operating temperature range ^[3]	0°C to +70°C
Supply voltage (V_{CC}) ^[1]	+4.5V to +5.5V
Ground voltage (V_{SS}) ^[2]	0V

^[1] $V_{CC} = V_{CCA} = V_{CCD}$

^[2] $V_{SS} = V_{SSA} = V_{SSD}$

^[3] Case Temperature



10. ELECTRICAL CHARACTERISTICS

10.1. PARAMETERS FOR PACKAGED PARTS

TABLE 8: DC PARAMETERS – Packaged Parts

PARAMETER	SYMBOL	MIN ^[2]	TYP ^[1]	MAX ^[2]	UNITS	CONDITIONS
Input Low Voltage	V _{IL}			0.8	V	
Input High Voltage	V _{IH}	2.0			V	
Output Low Voltage	V _{OL}			0.4	V	I _{OL} = 4.0 mA
Output High Voltage	V _{OH}	V _{CC} - 0.4			V	I _{OH} = -10 μA
$\overline{\text{OVF}}$ Output High Voltage	V _{OH1}	2.4			V	I _{OH} = -1.6 mA
$\overline{\text{EOM}}$ Output High Voltage	V _{OH2}	V _{CC} - 1.0	V _{CC} - 0.8		V	I _{OH} = -3.2 mA
V _{CC} Current (Operating)	I _{CC}		25	30	mA	R _{EXT} = ∞ ^[3]
V _{CC} Current (Standby)	I _{SB}		1	10	μA	^[3]
Input Leakage Current	I _{IL}			±1	μA	
Input Current HIGH w/Pull Down	I _{ILPD}			130	μA	Force V _{CC} ^[4]
Output Load Impedance	R _{EXT}	16			Ω	Speaker Load
Preamplifier Input Resistance	R _{MIC}	4	9	15	KΩ	MIC and MIC REF Pins
AUX IN Input Resistance	R _{AUX}	5	11	20	KΩ	
ANA IN Input Resistance	R _{ANA IN}	2.3	3	5	KΩ	
Preamplifier Gain 1	A _{PRE1}	21	24	26	dB	AGC = 0.0V
Preamplifier Gain 2	A _{PRE2}		-15	5	dB	AGC = 2.5V
AUX IN/SP+ Gain	A _{AUX}		0.98	1.0	V/V	
ANA IN to SP+/- Gain	A _{ARP}	21	23	26	dB	
AGC Output Resistance	R _{AGC}	2.5	5	9.5	KΩ	

Notes:

^[1] Typical values @ T_A = 25° and V_{CC} = 5.0V.

^[2] All Min/Max limits are guaranteed by Winbond via electrical testing or characterization. Not all specifications are 100 percent tested.

^[3] V_{CCA} and V_{CCD} connected together.

^[4] XCLK pin only.

ISD2560/75/90/120



TABLE 9: AC PARAMETERS – Packaged Parts

CHARACTERISTIC	SYMBOL	MIN ^[2]	TYP ^[1]	MAX ^[2]	UNITS	CONDITIONS
Sampling Frequency	F_S					
ISD2560			8.0		kHz	[7]
ISD2575			6.4		kHz	[7]
ISD2590			5.3		kHz	[7]
ISD25120			4.0		kHz	[7]
Filter Pass Band	F_{CF}					
ISD2560			3.4		kHz	3 dB Roll-Off Point ^{[3][8]}
ISD2575			2.7		kHz	3 dB Roll-Off Point ^{[3][8]}
ISD2590			2.3		kHz	3 dB Roll-Off Point ^{[3][8]}
ISD25120			1.7		kHz	3 dB Roll-Off Point ^{[3][8]}
Record Duration	T_{REC}					
ISD2560		58.1	60.0	62.0	sec	Commercial Operation ^[7]
ISD2575		72.6	75.0	77.5	sec	Commercial Operation ^[7]
ISD2590		87.1	90.0	93.0	sec	Commercial Operation ^[7]
ISD25120		116.1	120.0	123.9	sec	Commercial Operation ^[7]
Playback Duration	T_{PLAY}					
ISD2560		58.1	60.0	62.0	sec	Commercial Operation
ISD2575		72.6	75.0	77.5	sec	Commercial Operation
ISD2590		87.1	90.0	93.0	sec	Commercial Operation
ISD25120		116.1	120.0	123.9	sec	Commercial Operation
CE Pulse Width	T_{CE}		100		nsec	
Control/Address Setup Time	T_{SET}		300		nsec	
Control/Address Hold Time	T_{HOLD}		0		nsec	
Power-Up Delay	T_{PUD}					
ISD2560		24.1	25.0	27.8	msec	Commercial Operation
ISD2575		30.2	31.3	34.3	msec	Commercial Operation
ISD2590		36.2	37.5	40.8	msec	Commercial Operation
ISD25120		48.2	50.0	53.6	msec	Commercial Operation
PD Pulse Width (record)	T_{PDR}					
ISD2560			25.0		msec	
ISD2575			31.25		msec	
ISD2590			37.5		msec	
ISD25120			50.0		msec	



TABLE 9: AC PARAMETERS – Packaged Parts (Cont'd)

CHARACTERISTIC	SYMBOL	MIN ^[2]	TYP ^[1]	MAX ^[2]	UNITS	CONDITIONS
PD Pulse Width (Play)	T_{PDP}					
ISD2560			12.5		msec	
ISD2575			15.625		msec	
ISD2590			18.75		msec	
ISD25120			25.0		msec	
PD Pulse Width (Static)	T_{PDS}		100		nsec	^[6]
Power Down Hold	T_{PDH}		0		nsec	
EOM Pulse Width	T_{EOM}					
ISD2560			12.5		msec	
ISD2575			15.625		msec	
ISD2590			18.75		msec	
ISD25120			25.0		msec	
Overflow Pulse Width	T_{OVF}		6.5		μ sec	
Total Harmonic Distortion	THD		1	2	%	@ 1 kHz
Speaker Output Power	P_{OUT}		12.2	50	mW	$R_{EXT} = 16 \Omega$ ^[4]
Voltage Across Speaker Pins	V_{OUT}			2.5	V p-p	$R_{EXT} = 600 \Omega$
MIC Input Voltage	V_{IN1}			20	mV	Peak-to-Peak ^[5]
ANA IN Input Voltage	V_{IN2}			50	mV	Peak-to-Peak
AUX Input Voltage	V_{IN3}			1.25	V	Peak-to-Peak; $R_{EXT} = 16 \Omega$

Notes:

- ^[1] Typical values @ $T_A = 25^\circ\text{C}$ and $V_{CC} = 5.0\text{V}$.
- ^[2] All Min/Max limits are guaranteed by Winbond via electrical testing or characterization. Not all specifications are 100 percent tested.
- ^[3] Low-frequency cutoff depends upon the value of external capacitors (see Pin Descriptions)
- ^[4] From AUX IN; if ANA IN is driven at 50 mV p-p, the $P_{OUT} = 12.2$ mW, typical.
- ^[5] With 5.1 K Ω series resistor at ANA IN.
- ^[6] T_{PDS} is required during a static condition, typically overflow.
- ^[7] Sampling Frequency and playback Duration can vary as much as ± 2.25 percent over the commercial temperature range. For greater stability, an external clock can be utilized (see Pin Descriptions)
- ^[8] Filter specification applies to the antialiasing filter and the smoothing filter. Therefore, from input to output, expect a 6 dB drop by nature of passing through both filters.



10.1.1. Typical Parameter Variation with Voltage and Temperature (Packaged Parts)

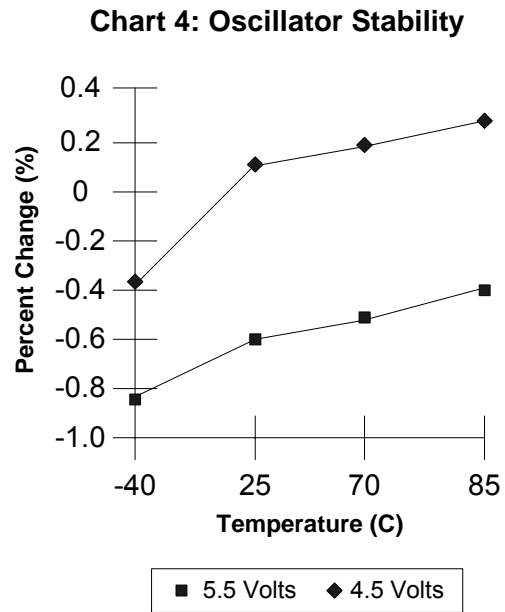
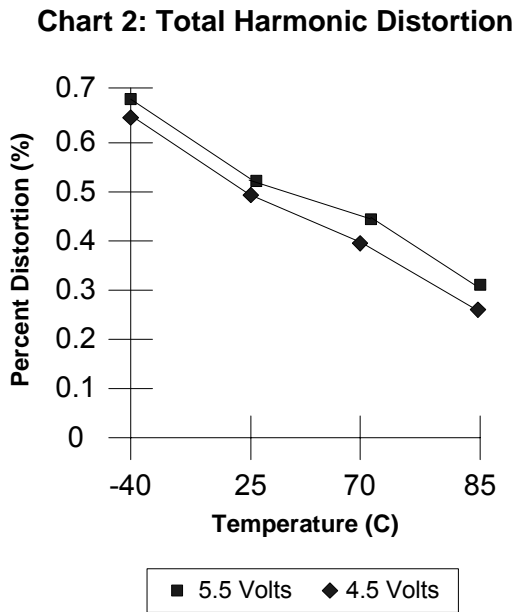
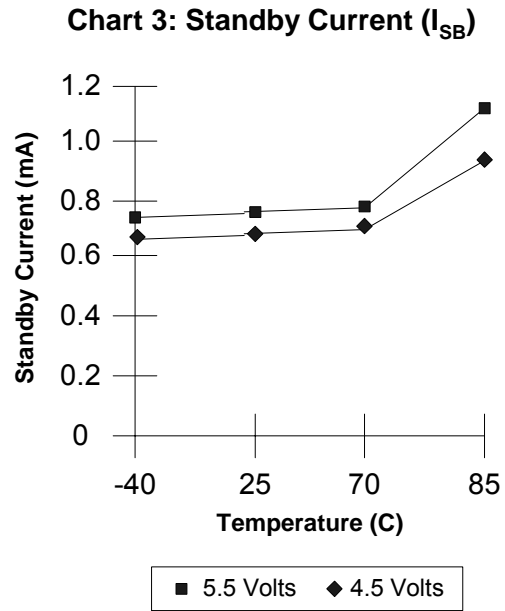
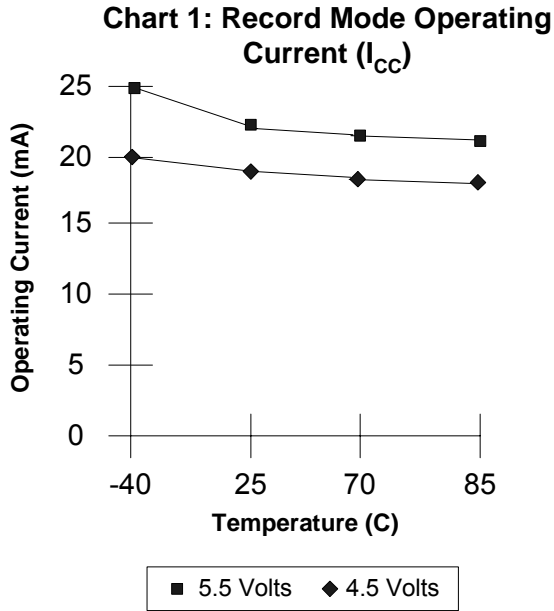



10.2. PARAMETERS FOR DIE

TABLE 10: DC PARAMETERS – Die

PARAMETER	SYMBOL	MIN ^[2]	TYP ^[1]	MAX ^[2]	UNITS	CONDITIONS
Input Low Voltage	V _{IL}			0.8	V	
Input High Voltage	V _{IH}	2.0			V	
Output Low Voltage	V _{OL}			0.4	V	I _{OL} = 4.0 mA
Output High Voltage	V _{OH}	V _{CC} - 0.4			V	I _{OH} = -10 μA
$\overline{\text{OVF}}$ Output High Voltage	V _{OH1}	2.4			V	I _{OH} = -1.6 mA
$\overline{\text{EOM}}$ Output High Voltage	V _{OH2}	V _{CC} - 1.0	V _{CC} - 0.8		V	I _{OH} = -3.2 mA
V _{CC} Current (Operating)	I _{CC}		25	30	mA	R _{EXT} = ∞ ^[3]
V _{CC} Current (Standby)	I _{SB}		1	10	μA	^[2]
Input Leakage Current	I _{IL}			±1	μA	
Input Current HIGH w/Pull Down	I _{ILPD}			130	μA	Force V _{CC} ^[4]
Output Load Impedance	R _{EXT}	16			Ω	Speaker Load
Preamp IN Input Resistance	R _{MIC}	4	9	15	KΩ	MIC and MIC REF Pads
AUX IN Input Resistance	R _{AUX}	5	11	20	KΩ	
ANA IN Input Resistance	R _{ANA IN}	2.3	3	5	KΩ	
Preamp Gain 1	A _{PRE1}	21	24	26	dB	AGC = 0.0V
Preamp Gain 2	A _{PRE2}		-15	5	dB	AGC = 2.5V
AUX IN/SP+ Gain	A _{AUX}		0.98	1.0	V/V	
ANA IN to SP+/- Gain	A _{ARP}	21	23	26	dB	
AGC Output Resistance	R _{AGC}	2.5	5	9.5	KΩ	

Notes:

^[1] Typical values @ T_A = 25°C and V_{CC} = 5.0V.

^[2] All Min/Max limits are guaranteed by Winbond via electrical testing or characterization. Not all specifications are 100 percent tested.

^[3] V_{CCA} and V_{CCD} connected together.

^[4] XCLK pad only.

ISD2560/75/90/120



TABLE 11: AC PARAMETERS – Die

CHARACTERISTIC	SYMBOL	MIN ^[2]	TYP ^[1]	MAX ^[2]	UNITS	CONDITIONS
Sampling Frequency	F_s					
ISD2560			8.0		kHz	[7]
ISD2575			6.4		kHz	[7]
ISD2590			5.3		kHz	[7]
ISD25120			4.0		kHz	[7]
Filter Pass Band	F_{CF}					
ISD2560			3.4		kHz	3 dB Roll-Off Point ^{[3][8]}
ISD2575			2.7		kHz	3 dB Roll-Off Point ^{[3][8]}
ISD2590			2.3		kHz	3 dB Roll-Off Point ^{[3][8]}
ISD25120			1.7		kHz	3 dB Roll-Off Point ^{[3][8]}
Record Duration	T_{REC}					
ISD2560		58.1	60.0	62.0	sec	Commercial Operation ^[7]
ISD2575		72.6	75.0	77.5	sec	Commercial Operation ^[7]
ISD2590		87.1	90.0	93.0	sec	Commercial Operation ^[7]
ISD25120		116.1	120.0	123.9	sec	Commercial Operation ^[7]
Playback Duration	T_{PLAY}					
ISD2560		58.1	60.0	62.0	sec	Commercial Operation ^[7]
ISD2575		72.6	75.0	77.5	sec	Commercial Operation ^[7]
ISD2590		87.1	90.0	93.0	sec	Commercial Operation ^[7]
ISD25120		116.1	120.0	123.9	sec	Commercial Operation ^[7]
\overline{CE} Pulse Width	T_{CE}		100		nsec	
Control/Address Setup Time	T_{SET}		300		nsec	
Control/Address Hold Time	T_{HOLD}		0		nsec	
Power-Up Delay	T_{PUD}					
ISD2560		24.1	25.0	27.8	msec	Commercial Operation
ISD2575		30.2	31.3	34.3	msec	Commercial Operation
ISD2590		36.2	37.5	40.8	msec	Commercial Operation
ISD25120		48.2	50.0	53.6	msec	Commercial Operation
PD Pulse Width (Record)	T_{PDR}					
ISD2560			25.0		msec	
ISD2575			31.25		msec	
ISD2590			37.5		msec	
ISD25120			50.0		msec	



TABLE 11: AC PARAMETERS – Die (Cont'd)

CHARACTERISTIC	SYMBOL	MIN ^[2]	TYP ^[1]	MAX ^[2]	UNITS	CONDITIONS
PD Pulse Width (Play)	T _{PDP}					
ISD2560			12.5		msec	
ISD2575			15.625		msec	
ISD2590			18.75		msec	
ISD25120			25.0		msec	
PD Pulse Width (Static)	T _{PDS}		100		nsec	[6]
Power Down Hold	T _{PDH}		0		nsec	
EOM Pulse Width	T _{EOM}					
ISD2560			12.5		msec	
ISD2575			15.625		msec	
ISD2590			18.75		msec	
ISD25120			25.0		msec	
Overflow Pulse Width	T _{OVF}		6.5		μsec	
Total Harmonic Distortion	THD		1	3	%	@ 1 kHz
Speaker Output Power	P _{OUT}		12.2	50	mW	R _{EXT} = 16 Ω ^[4]
Voltage Across Speaker Pins	V _{OUT}			2.5	V p-p	R _{EXT} = 600 Ω
MIC Input Voltage	V _{IN1}			20	mV	Peak-to-Peak ^[5]
ANA IN Input Voltage	V _{IN2}			50	mV	Peak-to-Peak
AUX Input Voltage	V _{IN3}			1.25	V	Peak-to-Peak; R _{EXT} = 16 Ω

Notes:

- [1] Typical values @ T_A = 25°C and V_{CC} = 5.0V.
- [2] All Min/Max limits are guaranteed by Winbond via electrical testing or characterization. Not all specifications are 100 percent tested.
- [3] Low-frequency cutoff depends upon the value of external capacitors (see Pin Descriptions)
- [4] From AUX IN; if ANA IN is driven at 50 mV p-p, the P_{OUT} = 12.2 mW, typical.
- [5] With 5.1 K Ω series resistor at ANA IN.
- [6] T_{PDS} is required during a static condition, typically overflow.
- [7] Sampling Frequency and playback Duration can vary as much as ±2.25 percent over the commercial temperature range. For greater stability, an external clock can be utilized (see Pin Descriptions)
- [8] Filter specification applies to the antialiasing filter and the smoothing filter. Therefore, from input to output, expect a 6 dB drop by nature of passing through both filters.



10.2.1. Typical Parameter Variation with Voltage and Temperature (Die)

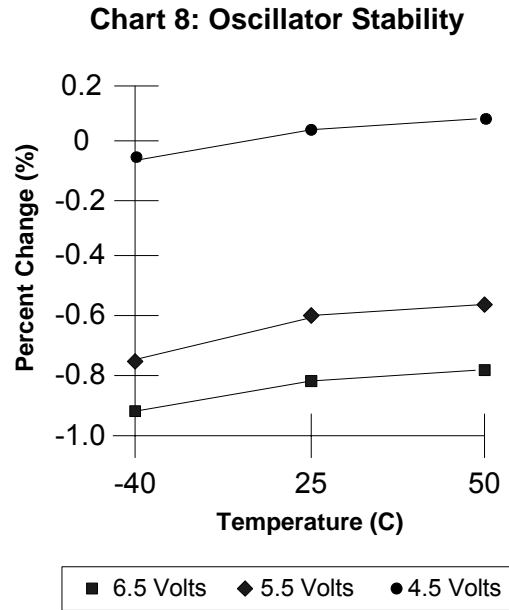
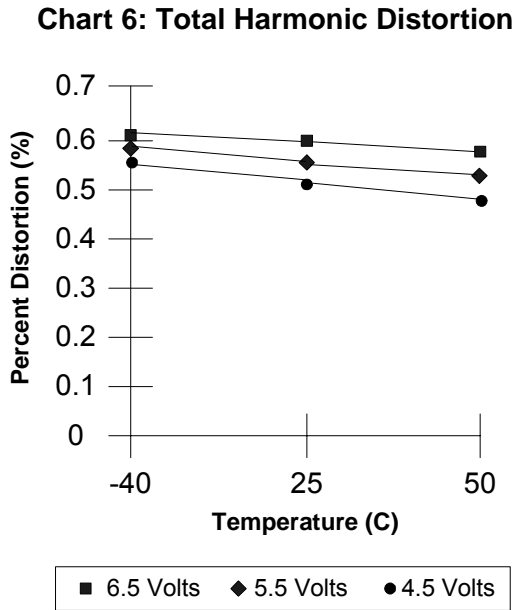
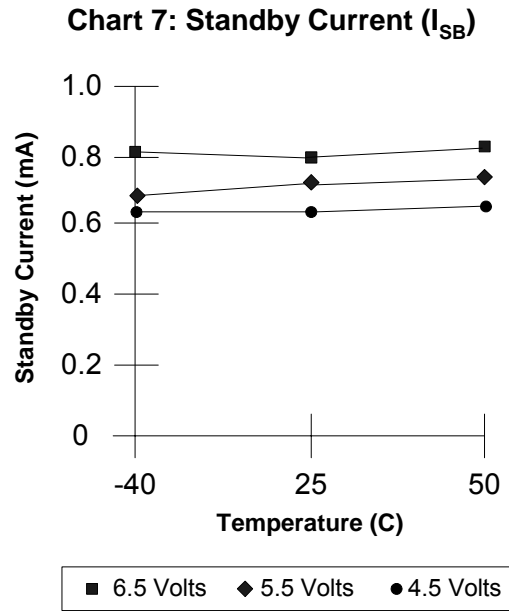
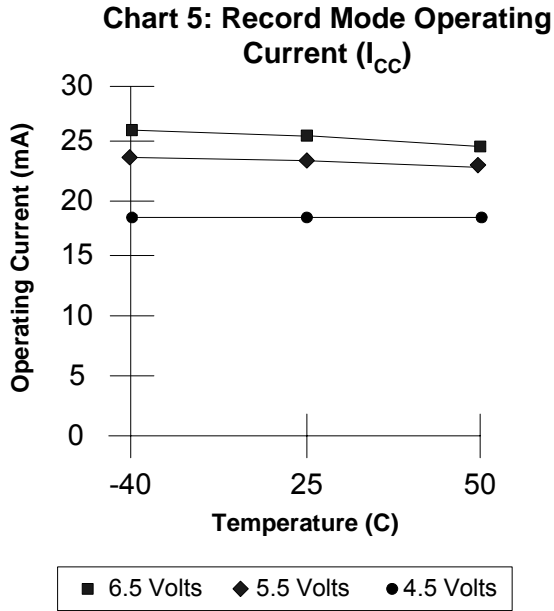



10.3. PARAMETERS FOR PUSH-BUTTON MODE

TABLE 12: PARAMETERS FOR PUSH-BUTTON MODE

PARAMETER	SYMBOL	MIN ^[2]	TYP ^[1]	MAX ^[2]	UNIT S	CONDITIONS
$\overline{\text{CE}}$ Pulse Width (Start/Pause)	T_{CE}		300		nsec	
Control/Address Setup Time	T_{SET}		300		nsec	
Power-Up Delay	T_{PUD}					
ISD2560			25.0		msec	
ISD2575			31.25		msec	
ISD2590			37.25		msec	
ISD25120			50.0		msec	
PD Pulse Width (Stop/Restart)	T_{PD}		300		nsec	
$\overline{\text{CE}}$ to $\overline{\text{EOM}}$ HIGH	T_{RUN}	25		400	nsec	
$\overline{\text{CE}}$ to $\overline{\text{EOM}}$ LOW	T_{PAUSE}	50		400	nsec	
$\overline{\text{CE}}$ HIGH Debounce	T_{DB}					
ISD2560		70		105	msec	
ISD2575		85		135	msec	
ISD2590		105		160	msec	
ISD25120		135		215	msec	

Notes:

^[1] Typical values @ $T_A = 25^\circ\text{C}$ and $V_{\text{CC}} = 5.0\text{V}$.

^[2] All Min/Max limits are guaranteed by Winbond via electrical testing or characterization. Not all specifications are 100 percent tested.



11. TYPICAL APPLICATION CIRCUIT

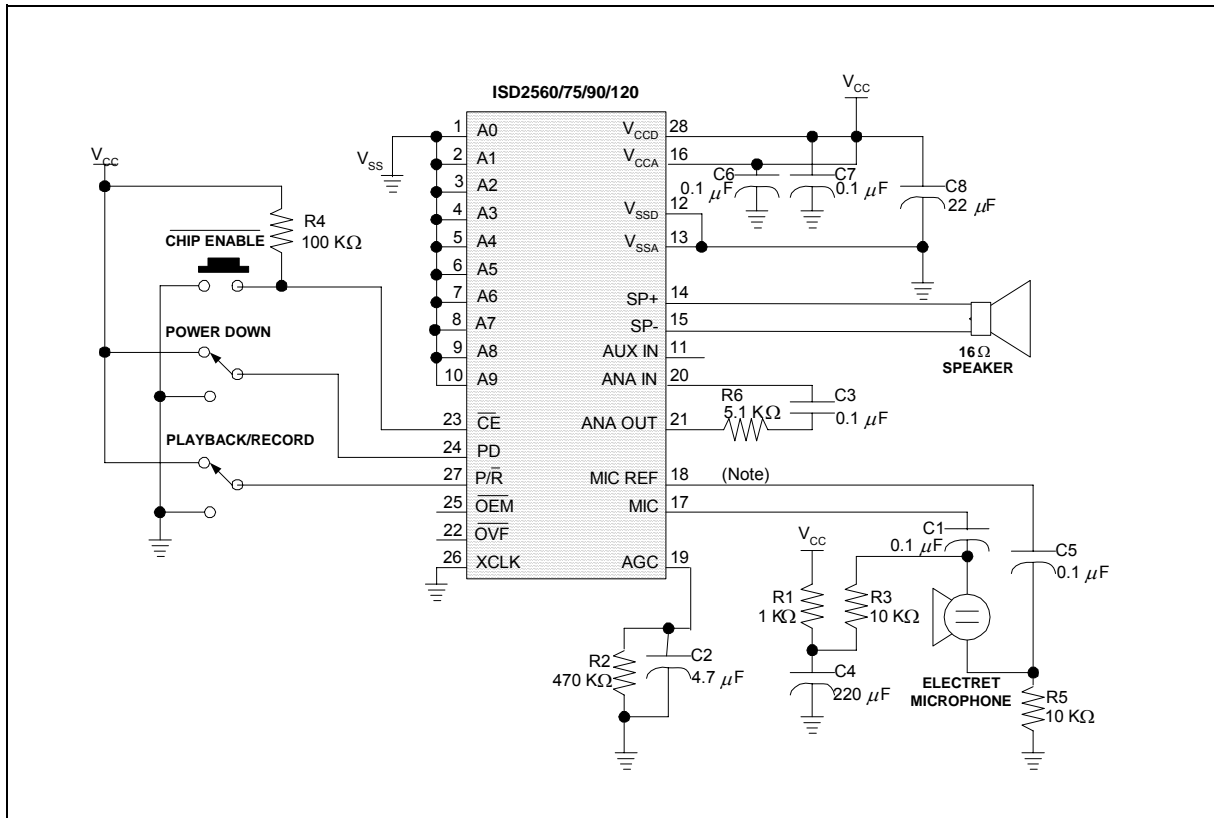

FIGURE 5: DESIGN SCHEMATIC

Note: If desired, pin 18 (PDIP package) may be left unconnected (microphone preamplifier noise will be higher). In this case, pin 18 must not be tied to any other signal or voltage. Additional design example schematics are provided below.



TABLE 13: APPLICATION EXAMPLE – BASIC DEVICE CONTROL

Control Step	Function	Action
1	Power up chip and select Record/Playback Mode	1. PD = LOW, 2. P/R = As desired
2	Set message address for record/playback	Set addresses A0-A9
3A	Begin playback	P/R = HIGH, CE = Pulse LOW
3B	Begin record	P/R = LOW, CE = LOW
4A	End playback	Automatic
4B	End record	PD or CE = HIGH

TABLE 14: APPLICATION EXAMPLE – PASSIVE COMPONENT FUNCTIONS

Part	Function	Comments
R1	Microphone power supply decoupling	Reduces power supply noise
R2	Release time constant	Sets release time for AGC
R3, R5	Microphone biasing resistors	Provides biasing for microphone operation
R4	Series limiting resistor	Reduces level to prevent distortion at higher supply voltages
R6	Series limiting resistor	Reduces level to high supply voltages
C1, C5	Microphone DC-blocking capacitor Low-frequency cutoff	Decouples microphone bias from chip. Provides single-pole low-frequency cutoff and command mode noise rejection.
C2	Attack/Release time constant	Sets attack/release time for AGC
C3	Low-frequency cutoff capacitor	Provides additional pole for low-frequency cutoff
C4	Microphone power supply decoupling	Reduces power supply noise
C6, C7, C8	Power supply capacitors	Filter and bypass of power supply

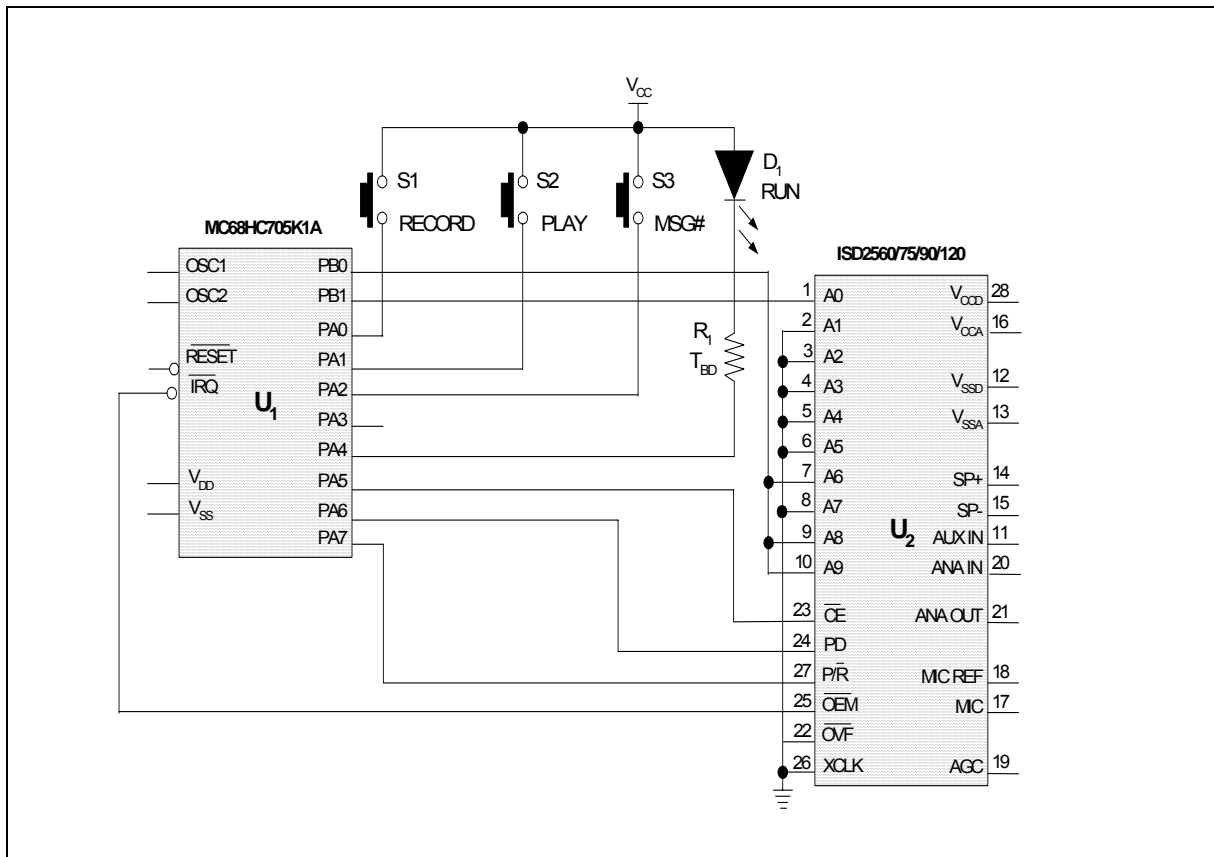

FIGURE 6: ISD2560/75/90/120 APPLICATION EXAMPLE – MICROCONTROLLER/ISD2500 INTERFACE

In this simplified block diagram of a microcontroller application, the Push-Button Mode and message cueing are used. The microcontroller is a 16-pin version with enough port pins for buttons, an LED, and the ISD2500 series device. The software can be written to use three buttons: one each for play and record, and one for message selection. Because the microcontroller is interpreting the buttons and commanding the ISD2500 device, software can be written for any function desired in a particular application.

Note: Winbond does not recommend connecting address lines directly to a microprocessor bus. Address lines should be externally latched.

ISD2560/75/90/120

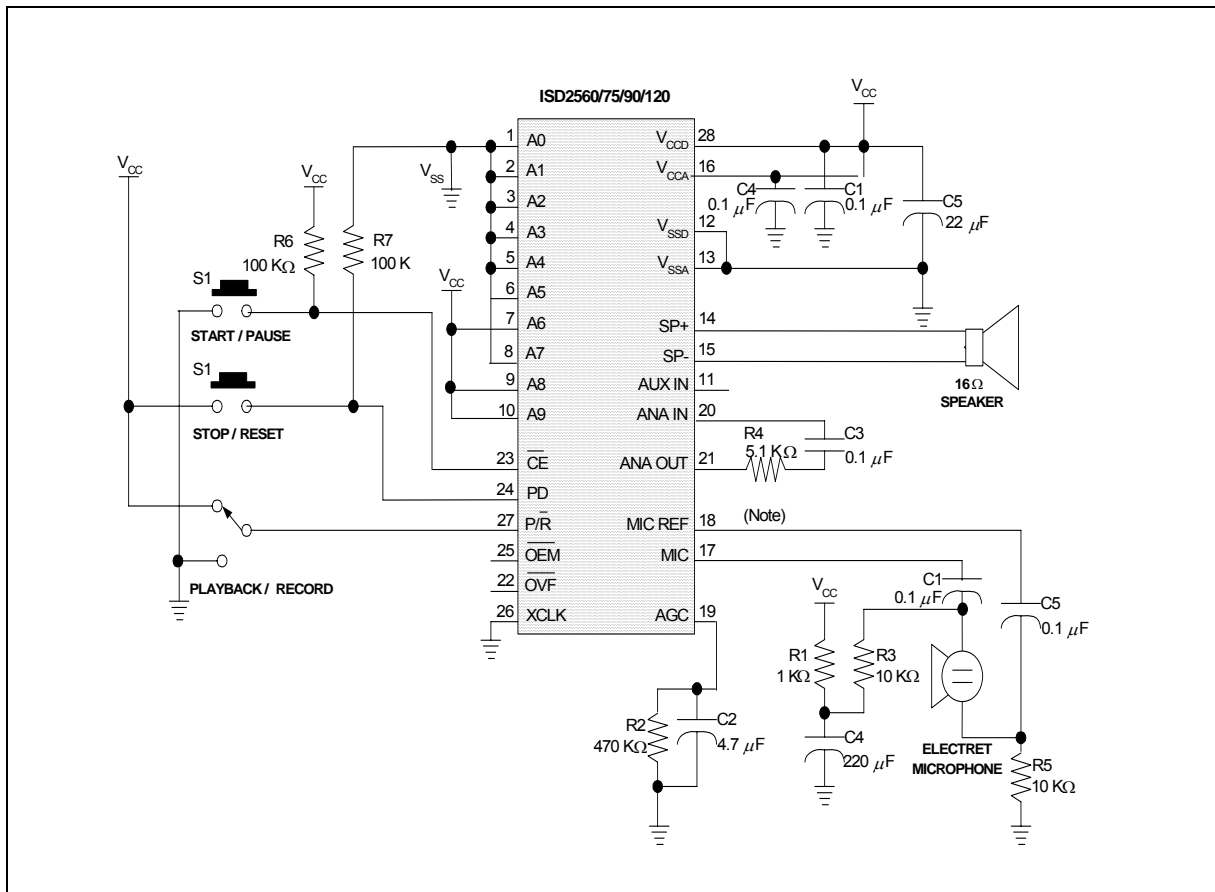

FIGURE 7: ISD2560/75/90/120 APPLICATION EXAMPLE – PUSH-BUTTON

Note: Please refer to page 13 for more details.



TABLE 15: APPLICATION EXAMPLE – PUSH-BUTTON CONTROL

Control Step	Function	Action
1	Select Record/Playback Mode	P/\bar{R} = As desired
2A	Begin playback	P/\bar{R} = HIGH, \overline{CE} = Pulse LOW
2B	Begin record	P/\bar{R} = LOW, \overline{CE} = Pulse LOW
3	Pause record or playback	\overline{CE} = Pulsed LOW
4A	End playback	Automatic at \overline{EOM} marker or PD = Pulsed HIGH
4B	End record	PD = Pulsed HIGH

TABLE 16: APPLICATION EXAMPLE – PASSIVE COMPONENT FUNCTIONS

Part	Function	Comments
R2	Release time constant	Sets release time for AGC
R4	Series limiting resistor	Reduces level to prevent distortion at higher supply voltages
R6, R7	Pull-up and pull-down resistors	Defines static state of inputs
C1, C4, C5	Power supply capacitors	Filters and bypass of power supply
C2	Attack/Release time constant	Sets attack/release time for AGC
C3	Low-frequency cutoff capacitor	Provides additional pole for low-frequency cutoff



12. PACKAGE DRAWING AND DIMENSIONS

12.1. 28-LEAD 300-MIL PLASTIC SMALL OUTLINE IC (SOIC)

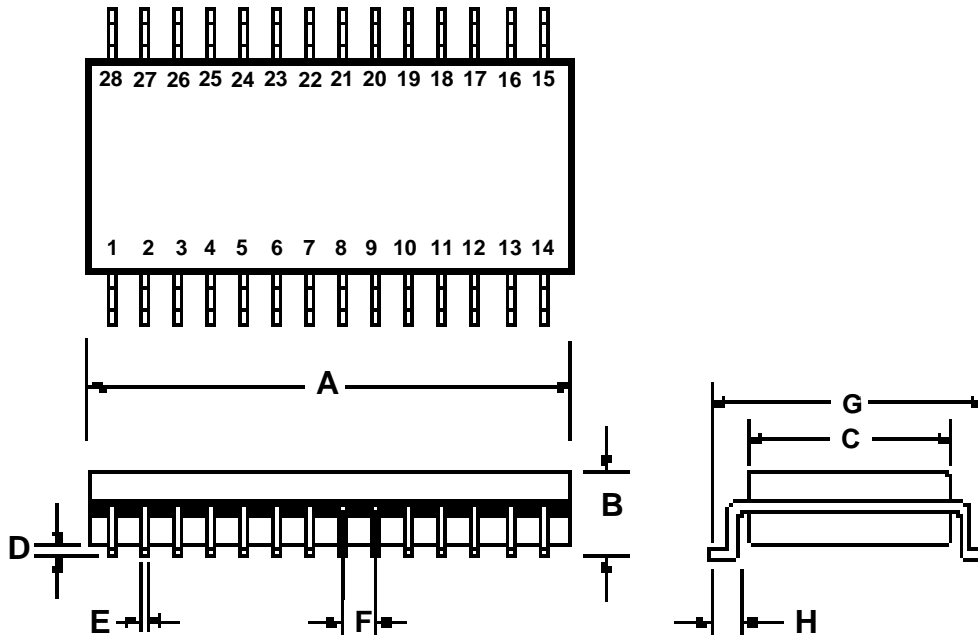

	INCHES			MILLIMETERS		
	Min	Nom	Max	Min	Nom	Max
A	0.701	0.706	0.711	17.81	17.93	18.06
B	0.097	0.101	0.104	2.46	2.56	2.64
C	0.292	0.296	0.299	7.42	7.52	7.59
D	0.005	0.009	0.0115	0.127	0.22	0.29
E	0.014	0.016	0.019	0.35	0.41	0.48
F		0.050			1.27	
G	0.400	0.406	0.410	10.16	10.31	10.41
H	0.024	0.032	0.040	0.61	0.81	1.02

Note: Lead coplanarity to be within 0.004 inches.



12.2. 28-LEAD 600-MIL PLASTIC DUAL INLINE PACKAGE (PDIP)

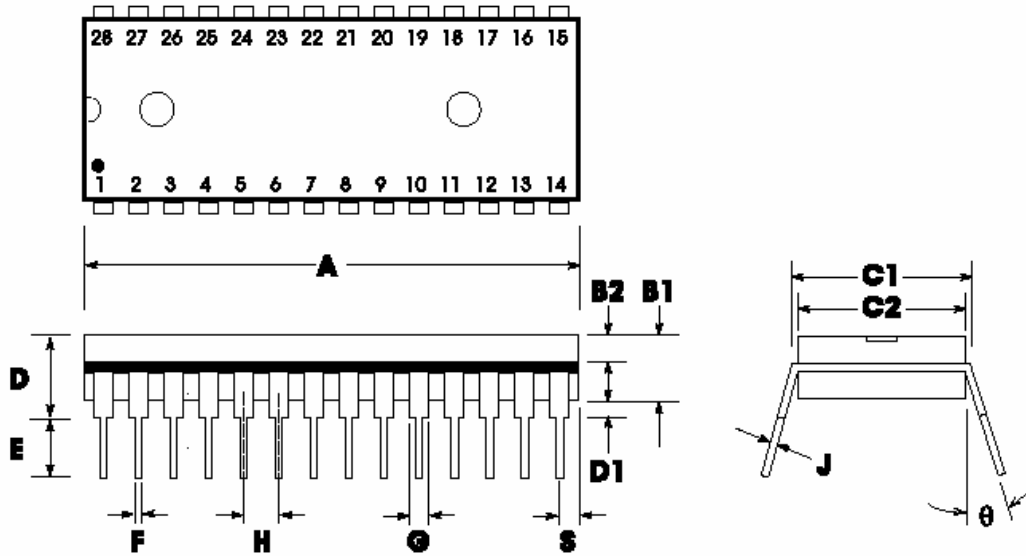

	INCHES			MILLIMETERS		
	Min	Nom	Max	Min	Nom	Max
A	1.445	1.450	1.455	36.70	36.83	36.96
B1		0.150			3.81	
B2	0.065	0.070	0.075	1.65	1.78	1.91
C1	0.600		0.625	15.24		15.88
C2	0.530	0.540	0.550	13.46	13.72	13.97
D			0.19			4.83
D1	0.015			0.38		
E	0.125		0.135	3.18		3.43
F	0.015	0.018	0.022	0.38	0.46	0.56
G	0.055	0.060	0.065	1.40	1.52	1.62
H		0.100			2.54	
J	0.008	0.010	0.012	0.20	0.25	0.30
S	0.070	0.075	0.080	1.78	1.91	2.03
q	0°		15°	0°		15°



12.3. 28-LEAD 8X13.4MM PLASTIC THIN SMALL OUTLINE PACKAGE (TSOP) TYPE 1

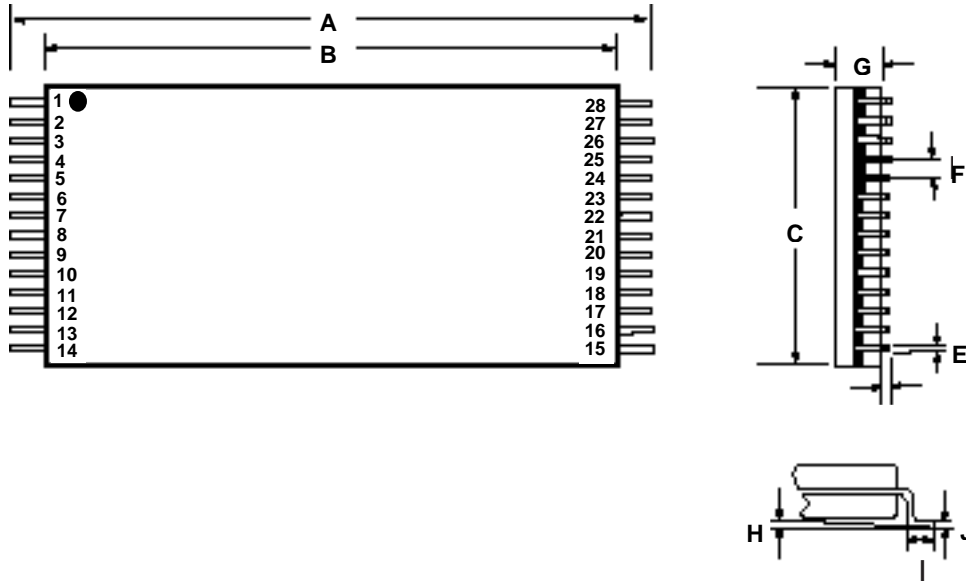

Plastic Thin Small Outline Package (TSOP) Type 1 Dimensions

	INCHES			MILLIMETERS		
	Min	Nom	Max	Min	Nom	Max
A	0.520	0.528	0.535	13.20	13.40	13.60
B	0.461	0.465	0.469	11.70	11.80	11.90
C	0.311	0.315	0.319	7.90	8.00	8.10
D	0.002		0.006	0.05		0.15
E	0.007	0.009	0.011	0.17	0.22	0.27
F		0.0217			0.55	
G	0.037	0.039	0.041	0.95	1.00	1.05
H	0°	3°	6°	0°	3°	6°
I	0.020	0.022	0.028	0.50	0.55	0.70
J	0.004		0.008	0.10		0.21

Note: Lead coplanarity to be within 0.004 inches.

ISD2560/75/90/120



12.4. 28-LEAD 8X13.4MM PLASTIC THIN SMALL OUTLINE PACKAGE (TSOP) TYPE 1 - IQC

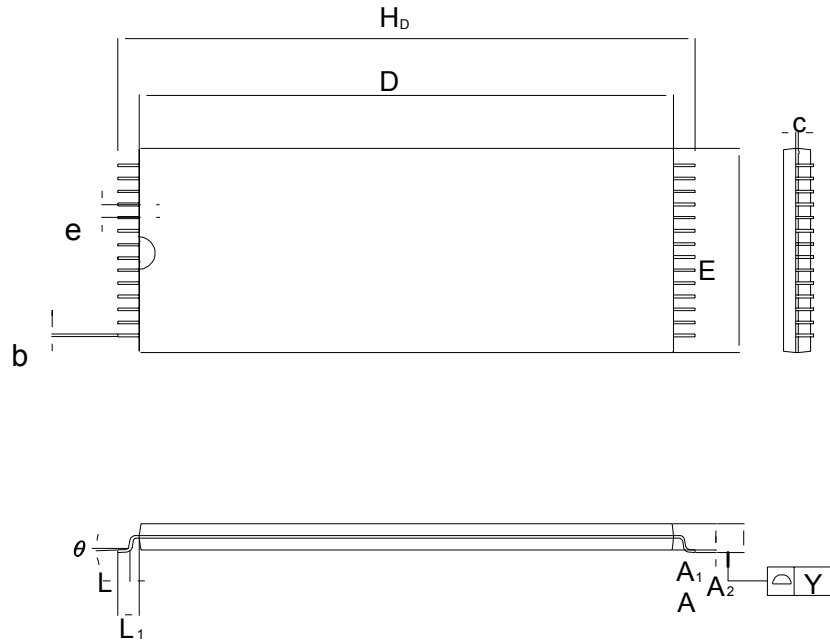

Symbol	Dimension in Inches			Dimension in mm		
	Min.	Nom.	Max.	Min.	Nom.	Max.
A	—	—	0.047	—	—	1.20
A1	0.002	—	0.006	0.05	—	0.15
A2	0.035	0.040	0.041	0.95	1.00	1.05
b	0.007	0.008	0.011	0.17	0.20	0.27
c	0.004	0.006	0.008	0.10	0.15	0.21
D	0.461	0.465	0.469	11.70	11.80	11.90
E	0.311	0.315	0.319	7.90	8.00	8.10
H _D	0.520	0.528	0.536	13.20	13.40	13.60
e	—	0.022	—	—	0.55	—
L	0.020	0.024	0.028	0.50	0.60	0.70
L ₁	—	0.031	—	—	0.80	—
Y	0.000	—	0.004	0.00	—	0.10
θ	0	3	5	0	3	5

ISD2560/75/90/120



12.5. ISD2560/75/95/120 PRODUCT BONDING PHYSICAL LAYOUT (DIE) ^[1]

ISD2560/75/95/120

- Die Dimensions
 - X: 149.5 ± 1 mils
 - Y: 262.0 ± 1 mils
- Die Thickness ^[2]
 - $11.5 \pm .4$ mils
- Pad Opening
 - 111 x 111 microns
 - 4.4 x 4.4 mils

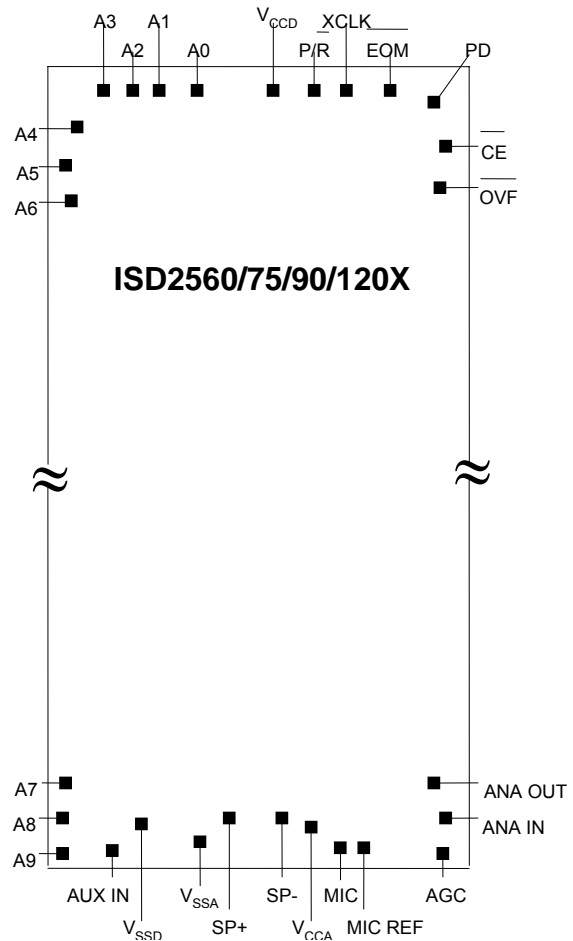

Notes:

- ^[1] The backside of die is internally connected to V_{SS} . It **MUST NOT** be connected to any other potential or damage may occur.
- ^[2] Die thickness is subject to change, please contact Winbond factory for status and availability.



ISD2560/75/90/120 PRODUCT PAD DESIGNATIONS

(with respect to die center)

Pad	Pad Name	X Axis (μm)	Y Axis (μm)
A0	Address 0	-897.9	3135.2
A1	Address 1	-1115.4	3135.2
A2	Address 2	-1331.0	3135.2
A3	Address 3	-1544.0	3135.2
A4	Address 4	-1640.4	2888.9
A5	Address 5	-1698.2	2671.0
A6	Address 6	-1698.2	2441.5
A7	Address 7	-1731.2	-2583.2
A8	Address 8	-1731.2	-2768.4
A9	Address 9	-1731.2	-3050.8
AUX IN	Auxiliary Input	-1410.2	-3115.7
V _{SSD}	V _{SS} Digital Power Supply	-1112.4	-3096.5
V _{SSA}	V _{SS} Analog Power Supply	-408.2	-3138.9
SP+	Speaker Output +	-46.65	-3068.4
SP-	Speaker Output -	386.1	-3068.4
V _{CCA}	V _{CC} Analog Power Supply	746.9	-3110.8
MIC	Microphone Input	1101.2	-3146.0
MIC REF	Microphone Reference	1294.7	-3146.0
AGC	Automatic Gain Control	1666.4	-3130.3
ANA IN	Analog Input	1728.6	-2654.0
ANA OUT	Analog Output	1700.9	-2411.0
$\overline{\text{OVF}}$	Overflow Output	1674.6	2489.5
$\overline{\text{CE}}$	Chip Enable Input	1726.7	2824.4
PD	Power Down Input	1730.5	3094.0
$\overline{\text{EOM}}$	End of Message	1341.2	3122.1
XCLK	No Connect (optional)	986.5	3160.7
P/ $\overline{\text{R}}$	Playback/Record	807.2	3163.4
V _{CCD}	V _{CC} Digital Power Supply	544.4	3159.6

ISD2560/75/90/120



13. ORDERING INFORMATION

Product Number Descriptor Key

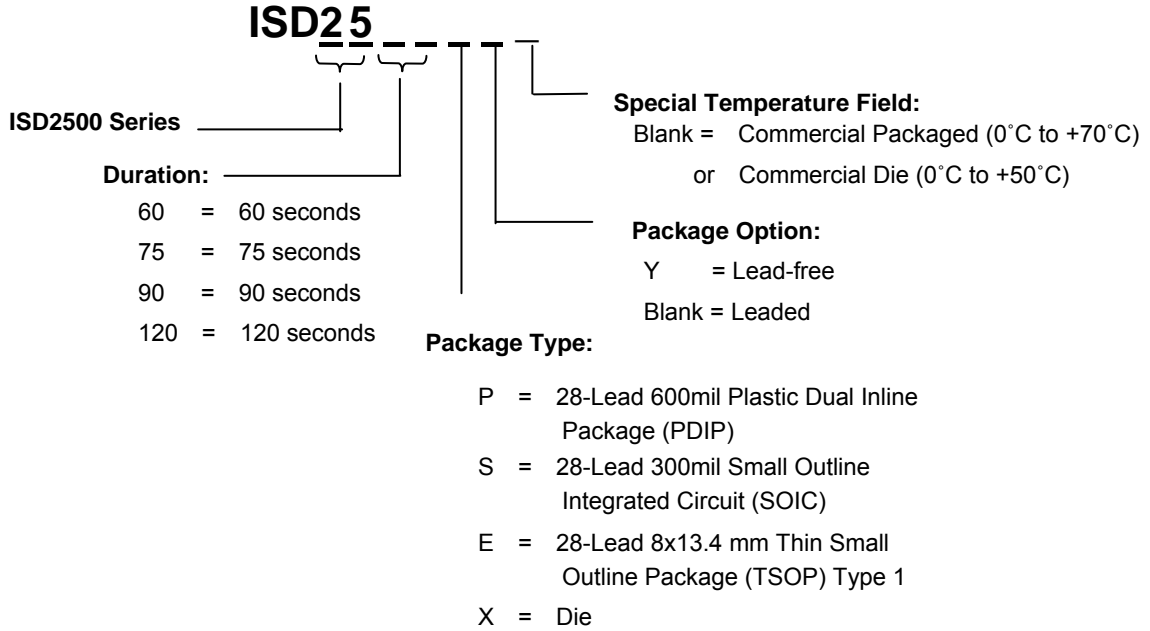

When ordering ISD2560/75/90/120 products, please refer to the following part numbers. Also, please contact the local Winbond Sales Representative or Distributor for availability on the lead-free parts.

Type	Package	60 Seconds	75 Seconds	90 Seconds	120 Seconds
Die	Die	ISD2560X	ISD2575X	ISD2590X	ISD25120X
Leaded	PDIP	ISD2560P	ISD2575P	ISD2590P	ISD25120P
	SOIC	ISD2560S	ISD2575S	ISD2590S	ISD25120S
	TSOP	ISD2560E	ISD2575E	ISD2590E	
Lead-Free	PDIP	ISD2560PY	ISD2575PY	ISD2590PY	ISD25120PY
	SOIC	ISD2560SY	ISD2575SY	ISD2590SY	ISD25120SY
	TSOP	ISD2560EY	ISD2575EY	ISD2590EY	

For the latest product information, access Winbond's worldwide website at <http://www.winbond-usa.com>

**14. VERSION HISTORY**

VERSION	DATE	DESCRIPTION
0	Apr. 1998	Preliminary Specifications
1.0	May 2003	Re-format the document. Update TSOP pin configuration. Revise Overflow pad designation.
1.1	Apr 2005	Revise the disclaim section.
1.2	Apr 2006	Update TSOP packaging information. Add lead-free option.



Winbond products are not designed, intended, authorized or warranted for use as components in systems or equipment intended for surgical implantation, atomic energy control instruments, airplane or spaceship instruments, transportation instruments, traffic signal instruments, combustion control instruments, or for other applications intended to support or sustain life. Furthermore, Winbond products are not intended for applications wherein failure of Winbond products could result or lead to a situation wherein personal injury, death or severe property or environmental damage could occur.

Winbond customers using or selling these products for use in such applications do so at their own risk and agree to fully indemnify Winbond for any damages resulting from such improper use or sales.

The contents of this document are provided only as a guide for the applications of Winbond products. Winbond makes no representation or warranties with respect to the accuracy or completeness of the contents of this publication and reserves the right to discontinue or make changes to specifications and product descriptions at any time without notice. No license, whether express or implied, to any intellectual property or other right of Winbond or others is granted by this publication. Except as set forth in Winbond's Standard Terms and Conditions of Sale, Winbond assumes no liability whatsoever and disclaims any express or implied warranty of merchantability, fitness for a particular purpose or infringement of any Intellectual property.

The contents of this document are provided "AS IS", and Winbond assumes no liability whatsoever and disclaims any express or implied warranty of merchantability, fitness for a particular purpose or infringement of any Intellectual property. In no event, shall Winbond be liable for any damages whatsoever (including, without limitation, damages for loss of profits, business interruption, loss of information) arising out of the use of or inability to use the contents of this documents, even if Winbond has been advised of the possibility of such damages.

Application examples and alternative uses of any integrated circuit contained in this publication are for illustration only and Winbond makes no representation or warranty that such applications shall be suitable for the use specified.

The 100-year retention and 100K record cycle projections are based upon accelerated reliability tests, as published in the Winbond Reliability Report, and are neither warranted nor guaranteed by Winbond. This product incorporates SuperFlash®.

Information contained in this ISD® ChipCorder® datasheet supersedes all data for the ISD ChipCorder products published by ISD® prior to August, 1998.

This datasheet and any future addendum to this datasheet is(are) the complete and controlling ISD® ChipCorder® product specifications. In the event any inconsistencies exist between the information in this and other product documentation, or in the event that other product documentation contains information in addition to the information in this, the information contained herein supersedes and governs such other information in its entirety. This datasheet is subject to change without notice.

Copyright© 2005, Winbond Electronics Corporation. All rights reserved. ChipCorder® and ISD® are trademarks of Winbond Electronics Corporation. SuperFlash® is the trademark of Silicon Storage Technology, Inc. All other trademarks are properties of their respective owners.

*Please note that all data and specifications are subject to change without notice.
All the trademarks of products and companies mentioned in this datasheet belong to their respective owners.*

Looking for pricing, stock, or lifecycle information?

Click below to explore more details on WIN SOURCE:

- ⊖ [View ISD2575PY on WIN SOURCE](#)
- ⊖ [Nuvoton Technology Corporation of America Information](#)

Optimize Your Supply Chain with WIN SOURCE Solutions

- ✓ Global Sourcing Solution
- ✓ Obsolete Management
- ✓ Cost Control Management
- ✓ Shortage Management
- ✓ Alternative Solution
- ✓ Excess Inventory Management