



**THE DATASHEET OF
IS63WV1024BLL-12TLI**



128K x 8 HIGH-SPEED CMOS STATIC RAM

MAY 2012

FEATURES

- High-speed access time:
12 ns: 3.3V \pm 10%
15 ns: 2.5V – 3.6V
- High-performance, low-power CMOS process
- CMOS Low Power Operation
50 mW (typical) operating current
25 μ W (typical) standby current
- Multiple center power and ground pins for greater noise immunity
- Easy memory expansion with \overline{CE} and \overline{OE} options
- \overline{CE} power-down
- Fully static operation: no clock or refresh required
- TTL compatible inputs and outputs
- Packages available:
 - 32-pin TSOP (Type II)
 - 32-pin sTSOP (Type I)
 - 48-Ball miniBGA (6mm x 8mm)
 - 32-pin 300-mil SOJ
- Lead-free available

DESCRIPTION

The *ISSI* IS63/64WV1024BLL is a very high-speed, low power, 131,072-word by 8-bit CMOS static RAM. The IS63/64WV1024BLL is fabricated using *ISSI*'s high-performance CMOS technology. This highly reliable process coupled with innovative circuit design techniques, yields higher performance and low power consumption devices.

When \overline{CE} is HIGH (deselected), the device assumes a standby mode at which the power dissipation can be reduced down to 25 μ W (typical) with CMOS input levels.

The IS63/64WV1024BLL operates from a single V_{DD} power supply. The IS63/64WV1024BLL is available in 32-pin TSOP (Type II), 32-pin sTSOP (Type I), 48-Ball miniBGA (6mm x 8mm), and 32-pin SOJ (300-mil) packages.

FUNCTIONAL BLOCK DIAGRAM

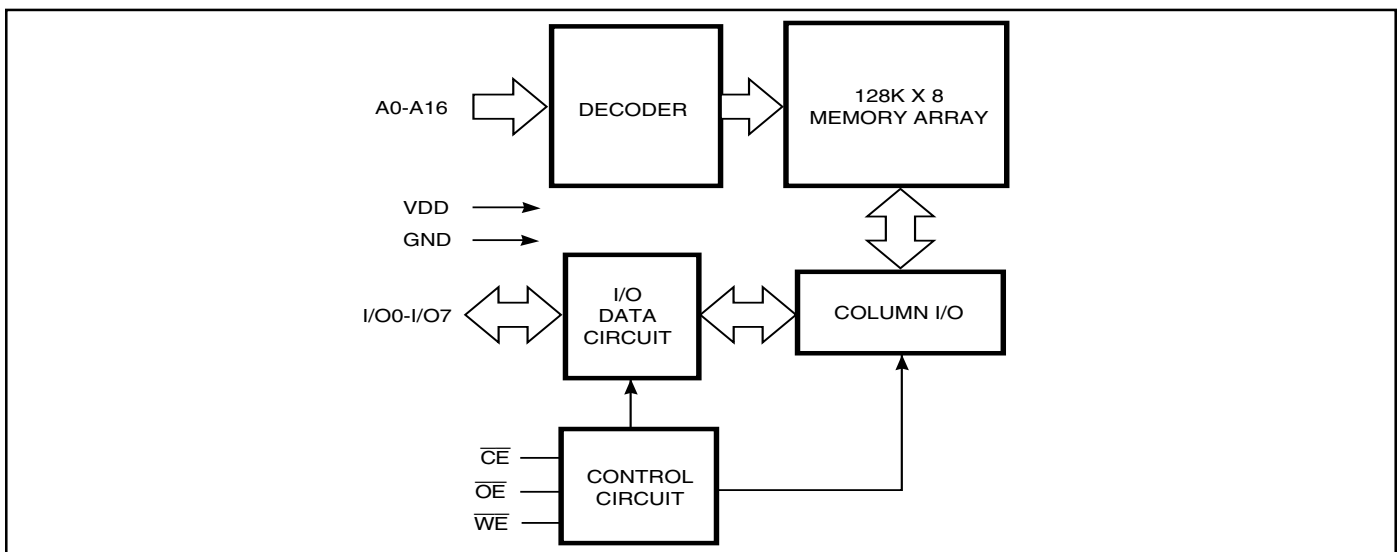

Copyright © 2012 Integrated Silicon Solution, Inc. All rights reserved. ISSI reserves the right to make changes to this specification and its products at any time without notice. ISSI assumes no liability arising out of the application or use of any information, products or services described herein. Customers are advised to obtain the latest version of this device specification before relying on any published information and before placing orders for products.

Integrated Silicon Solution, Inc. does not recommend the use of any of its products in life support applications where the failure or malfunction of the product can reasonably be expected to cause failure of the life support system or to significantly affect its safety or effectiveness. Products are not authorized for use in such applications unless Integrated Silicon Solution, Inc. receives written assurance to its satisfaction, that:

- a.) the risk of injury or damage has been minimized;
- b.) the user assume all such risks; and
- c.) potential liability of Integrated Silicon Solution, Inc is adequately protected under the circumstances

PIN CONFIGURATION

32-Pin SOJ

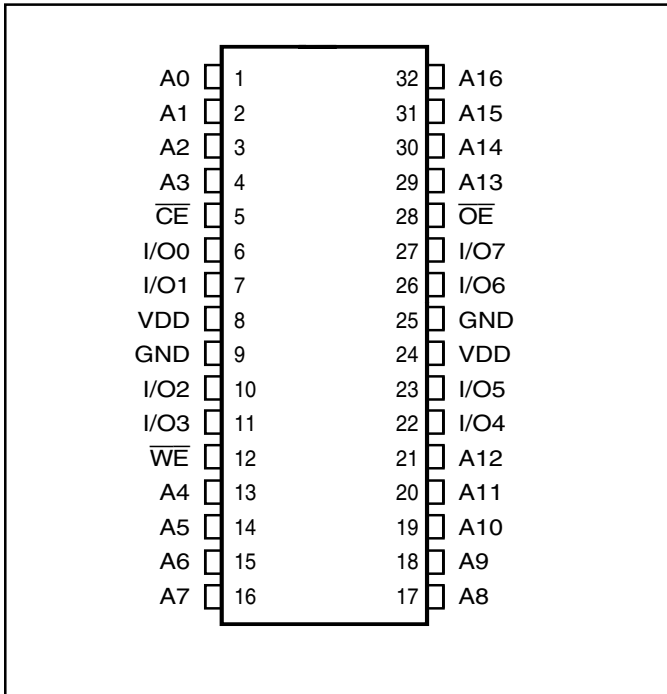

PIN CONFIGURATION

32-Pin TSOP (Type II) (T)
32-Pin sTSOP (Type I) (H)

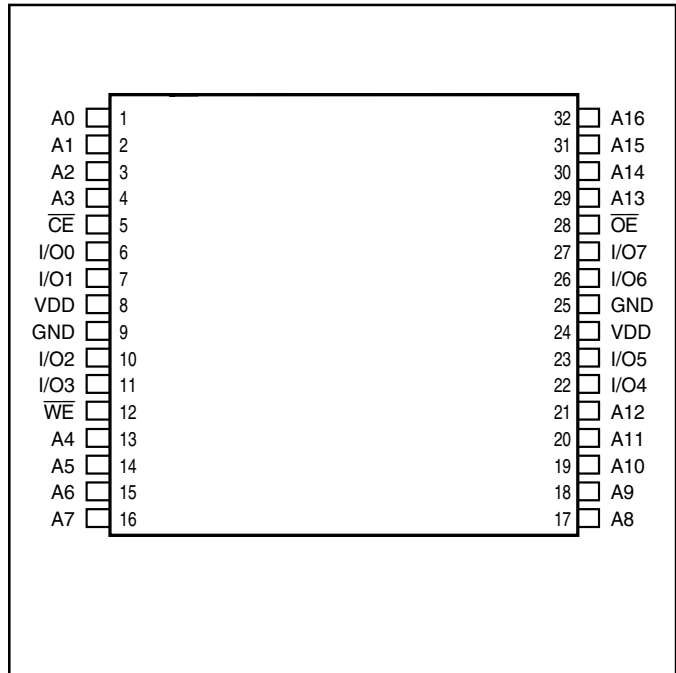

PIN DESCRIPTIONS

A0-A16	Address Inputs
\overline{CE}	Chip Enable Input
\overline{OE}	Output Enable Input
\overline{WE}	Write Enable Input
I/O0-I/O7	Bidirectional Ports
V _{DD}	Power
GND	Ground

PIN CONFIGURATION

48-mini BGA (B) (6 mm x 8 mm)

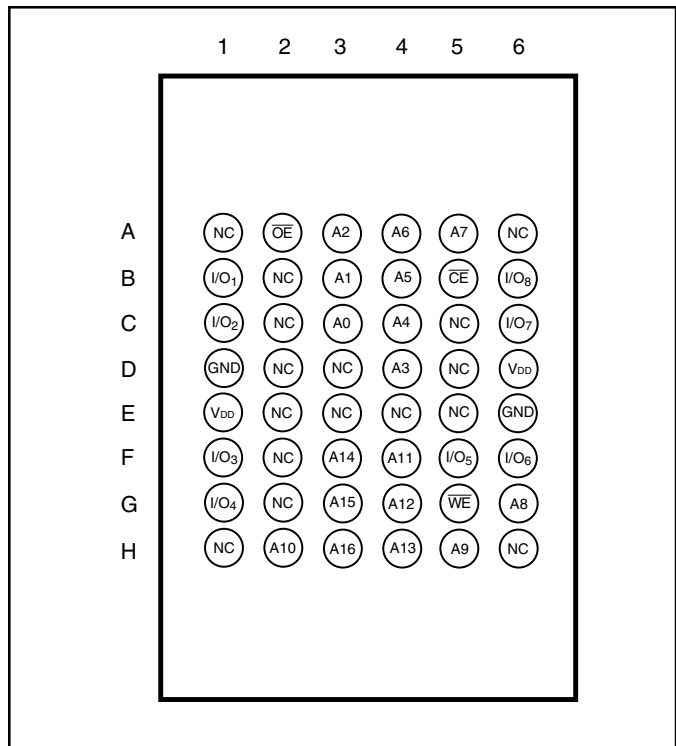

TRUTH TABLE

Mode	\overline{WE}	\overline{CE}	\overline{OE}	I/O Operation	V _{DD} Current
Not Selected (Power-down)	X	H	X	High-Z	ISB1, ISB2
Output Disabled	H	L	H	High-Z	I _{CC1} , I _{CC2}
Read	H	L	L	D _{OUT}	I _{CC1} , I _{CC2}
Write	L	L	X	D _{IN}	I _{CC1} , I _{CC2}

ABSOLUTE MAXIMUM RATINGS⁽¹⁾

Symbol	Parameter	Value	Unit
V _{TERM}	Terminal Voltage with Respect to GND	-0.5 to V _{DD} +0.5	V
T _{STG}	Storage Temperature	-65 to +150	°C
P _T	Power Dissipation	1.5	W
V _{DD}	V _{DD} Related to GND	-0.2 to +3.9	V

Note:

1. Stress greater than those listed under ABSOLUTE MAXIMUM RATINGS may cause permanent damage to the device. This is a stress rating only and functional operation of the device at these or any other conditions above those indicated in the operational sections of this specification is not implied. Exposure to absolute maximum rating conditions for extended periods may affect reliability.

OPERATING RANGE (V_{DD})

Range	Ambient Temperature	V _{DD} (15 ns)	V _{DD} (12 ns)
Commercial	0°C to +70°C	2.5V-3.6V	3.3V ± 10%
Industrial	-40°C to +85°C	2.5V-3.6V	3.3V ± 10%
Automotive	-40°C to +125°C	2.5V-3.6V	3.3V + 10%

DC ELECTRICAL CHARACTERISTICS (Over Operating Range)

V_{DD} = 2.5V-3.6V

Symbol	Parameter	Test Conditions	Min.	Max.	Unit
V _{OH}	Output HIGH Voltage	V _{DD} = Min., I _{OH} = -1.0 mA	2.3	—	V
V _{OL}	Output LOW Voltage	V _{DD} = Min., I _{OL} = 1.0 mA	—	0.4	V
V _{IH}	Input HIGH Voltage		2.0	V _{DD} + 0.3	V
V _{IL}	Input LOW Voltage ⁽¹⁾		-0.3	0.8	V
I _{LI}	Input Leakage	GND ≤ V _{IN} ≤ V _{DD}	-2	2	μA
I _{LO}	Output Leakage	GND ≤ V _{OUT} ≤ V _{DD} , Outputs Disabled	-2	2	μA

Note:

- V_{IL}(min.) = -0.3V DC; V_{IL}(min.) = -2.0V AC (pulse width < 10 ns). Not 100% tested.
V_{IH}(max.) = V_{DD} + 0.3V DC; V_{IH}(max.) = V_{DD} + 2.0V AC (pulse width < 10 ns). Not 100% tested.

DC ELECTRICAL CHARACTERISTICS (Over Operating Range)

V_{DD} = 3.3V ± 10%

Symbol	Parameter	Test Conditions	Min.	Max.	Unit
V _{OH}	Output HIGH Voltage	V _{DD} = Min., I _{OH} = -4.0 mA	2.4	—	V
V _{OL}	Output LOW Voltage	V _{DD} = Min., I _{OL} = 8.0 mA	—	0.4	V
V _{IH}	Input HIGH Voltage		2	V _{DD} + 0.3	V
V _{IL}	Input LOW Voltage ⁽¹⁾		-0.3	0.8	V
I _{LI}	Input Leakage	GND ≤ V _{IN} ≤ V _{DD}	-2	2	μA
I _{LO}	Output Leakage	GND ≤ V _{OUT} ≤ V _{DD} , Outputs Disabled	-2	2	μA

Note:

- V_{IL}(min.) = -0.3V DC; V_{IL}(min.) = -2.0V AC (pulse width < 10 ns). Not 100% tested.
V_{IH}(max.) = V_{DD} + 0.3V DC; V_{IH}(max.) = V_{DD} + 2.0V AC (pulse width < 10 ns). Not 100% tested.

POWER SUPPLY CHARACTERISTICS⁽¹⁾ (Over Operating Range)

Symbol	Parameter	Test Conditions	Options	-12 ns		-15 ns		Unit
				Min.	Max.	Min.	Max.	
I _{CC}	V _{DD} Dynamic Operating Supply Current	V _{DD} = Max., I _{OUT} = 0 mA, f = f _{MAX}	COM.	—	35	—	30	mA
			IND.	—	45	—	40	
			AUTO	—	60	—	50	
			typ. ⁽²⁾	—	20	—	20	
I _{CC1}	Operating Supply Current	V _{DD} = Max., I _{OUT} = 0mA, f = 0	COM.	—	5	—	5	mA
			IND.	—	5	—	5	
			AUTO	—	5	—	5	
I _{SB1}	TTL Standby Current (TTL Inputs)	V _{DD} = Max., V _{IN} = V _{IH} or V _{IL} CE ≥ V _{IH} , f = 0	COM.	—	3	—	3	mA
			IND.	—	4	—	4	
			AUTO	—	4	—	4	
I _{SB2}	CMOS Standby Current (CMOS Inputs)	V _{DD} = Max., CE ≥ V _{DD} - 0.2V, V _{IN} ≥ V _{DD} - 0.2V, or V _{IN} ≤ 0.2V, f = 0	COM.	—	20	—	20	uA
			IND.	—	50	—	50	
			AUTO	—	75	—	75	
			typ. ⁽²⁾	—	6	—	6	

Note:

- At f = f_{MAX}, address and data inputs are cycling at the maximum frequency, f = 0 means no input lines change.
- Typical values are measured at V_{DD}=2.5V, T_A=25°C. Not 100% tested.

CAPACITANCE⁽¹⁾

Symbol	Parameter	Conditions	Max.	Unit
C _{IN}	Input Capacitance	V _{IN} = 0V	6	pF
C _{OUT}	Input/Output Capacitance	V _{OUT} = 0V	8	pF

Note:

- Tested initially and after any design or process changes that may affect these parameters.

AC TEST CONDITIONS

Parameter	Unit (2.5V-3.6V)	Unit (3.3V ± 10%)
Input Pulse Level	0V to V _{DD} V	0V to V _{DD} V
Input Rise and Fall Times	1.5ns	1.5ns
Input and Output Timing and Reference Level (V _{Ref})	V _{DD} /2	V _{DD} /2 + 0.05
Output Load	See Figures 1a and 1b	See Figures 1a and 1b

AC TEST LOADS

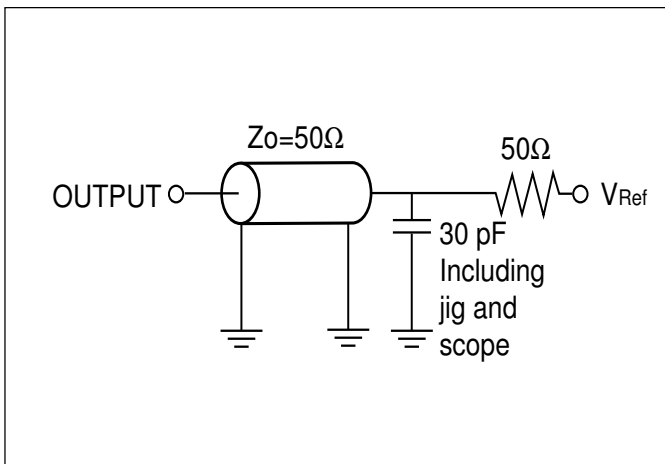

Figure 1a.

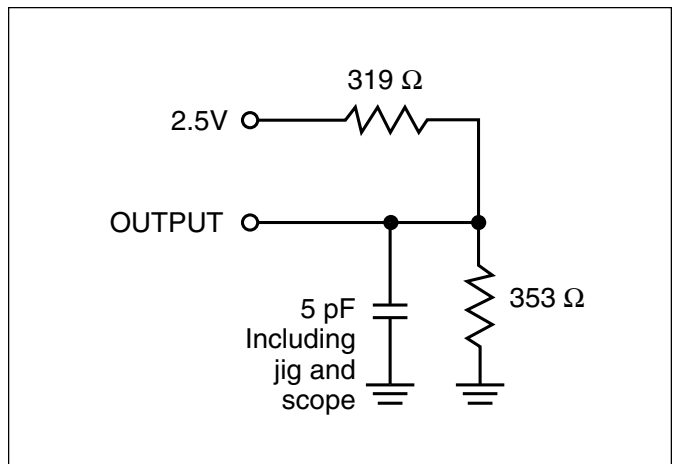

Figure 1b.

READ CYCLE SWITCHING CHARACTERISTICS⁽¹⁾ (Over Operating Range)

Symbol	Parameter	-12 ns		-15 ns		Unit
		Min.	Max.	Min.	Max.	
t _{RC}	Read Cycle Time	12	—	15	—	ns
t _{AA}	Address Access Time	—	12	—	15	ns
t _{OHA}	Output Hold Time	3	—	3	—	ns
t _{ACE}	$\overline{\text{CE}}$ Access Time	—	12	—	15	ns
t _{DOE}	$\overline{\text{OE}}$ Access Time	—	6	—	7	ns
t _{LZOE⁽²⁾}	$\overline{\text{OE}}$ to Low-Z Output	0	—	0	—	ns
t _{HZOE⁽²⁾}	$\overline{\text{OE}}$ to High-Z Output	0	6	0	6	ns
t _{LZCE⁽²⁾}	$\overline{\text{CE}}$ to Low-Z Output	3	—	3	—	ns
t _{HZCE⁽²⁾}	$\overline{\text{CE}}$ to High-Z Output	0	6	0	6	ns
t _{PU}	$\overline{\text{CE}}$ to Power Up Time	0	—	0	—	ns
t _{PD}	$\overline{\text{CE}}$ to Power Down Time	—	12	—	15	ns

Notes:

1. Test conditions assume signal transition times of 3 ns or less, timing reference levels of 1.25V, input pulse levels of 0.4V to V_{DD}-0.3V and output loading specified in Figure 1.
2. Tested with the loading specified in Figure 1. Transition is measured ±500 mV from steady-state voltage. Not 100% tested.

AC WAVEFORMS

READ CYCLE NO. 1^(1,2)

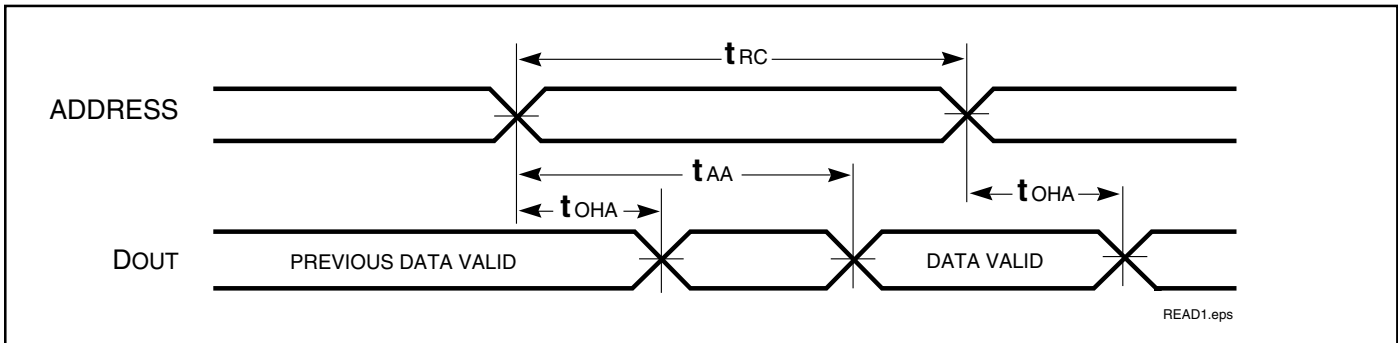

READ CYCLE NO. 2^(1,3)

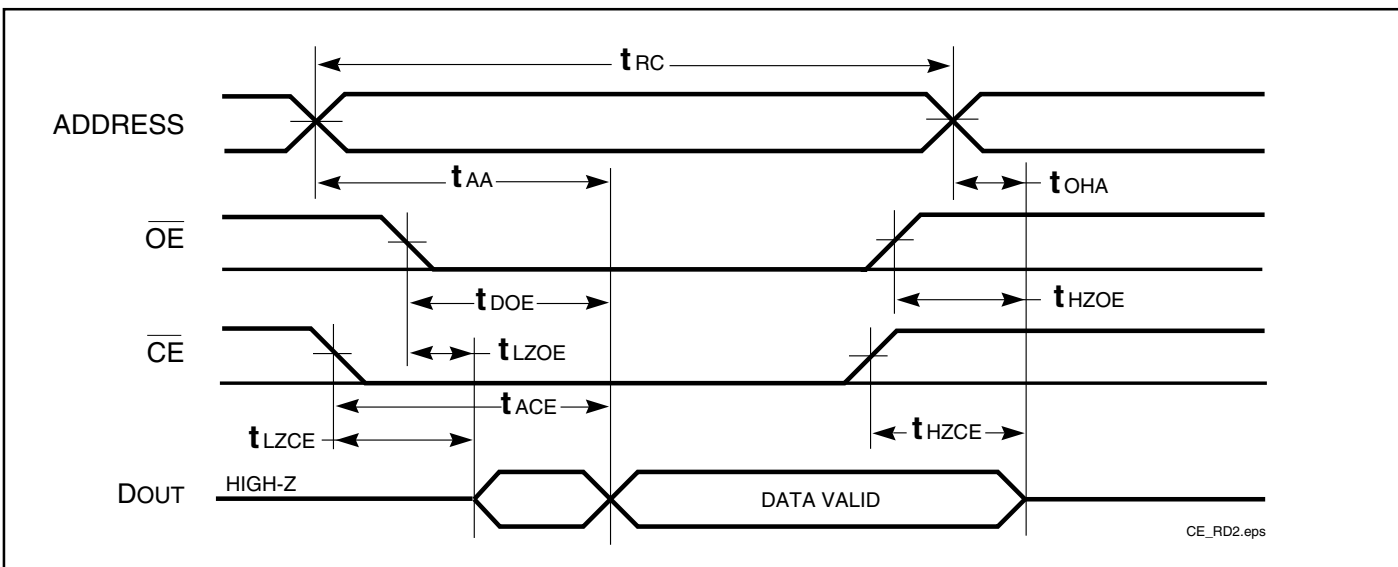

Notes:

1. \overline{WE} is HIGH for a Read Cycle.
2. The device is continuously selected. \overline{OE} , $\overline{CE} = V_{IL}$.
3. Address is valid prior to or coincident with \overline{CE} LOW transitions.

WRITE CYCLE SWITCHING CHARACTERISTICS^(1,3) (Over Operating Range)

Symbol	Parameter	-12 ns		-15 ns		Unit
		Min.	Max.	Min.	Max.	
t_{WC}	Write Cycle Time	12	—	15	—	ns
t_{SCE}	\overline{CE} to Write End	9	—	10	—	ns
t_{AW}	Address Setup Time to Write End	9	—	10	—	ns
t_{HA}	Address Hold from Write End	0	—	0	—	ns
t_{SA}	Address Setup Time	0	—	0	—	ns
$t_{PWE_1}^{(1)}$	\overline{WE} Pulse Width (\overline{OE} High)	9	—	10	—	ns
$t_{PWE_2}^{(2)}$	\overline{WE} Pulse Width (\overline{OE} Low)	11	—	12	—	ns
t_{SD}	Data Setup to Write End	9	—	9	—	ns
t_{HD}	Data Hold from Write End	0	—	0	—	ns
$t_{HZWE}^{(2)}$	\overline{WE} LOW to High-Z Output	—	6	—	7	ns
$t_{LZWE}^{(2)}$	\overline{WE} HIGH to Low-Z Output	3	—	3	—	ns

Notes:

1. Test conditions assume signal transition times of 3ns or less, timing reference levels of 1.25V, input pulse levels of 0.4V to $V_{DD}-0.3V$ and output loading specified in Figure 1a.
2. Tested with the loading specified in Figure 1b. Transition is measured ± 500 mV from steady-state voltage. Not 100% tested.
3. The internal write time is defined by the overlap of \overline{CE} LOW and \overline{WE} LOW. All signals must be in valid states to initiate a Write, but any one can go inactive to terminate the Write. The Data Input Setup and Hold timing are referenced to the rising or falling edge of the signal that terminates the Write.

AC WAVEFORMS

WRITE CYCLE NO. 1^(1,2) (\overline{CE} Controlled, \overline{OE} = HIGH or LOW)

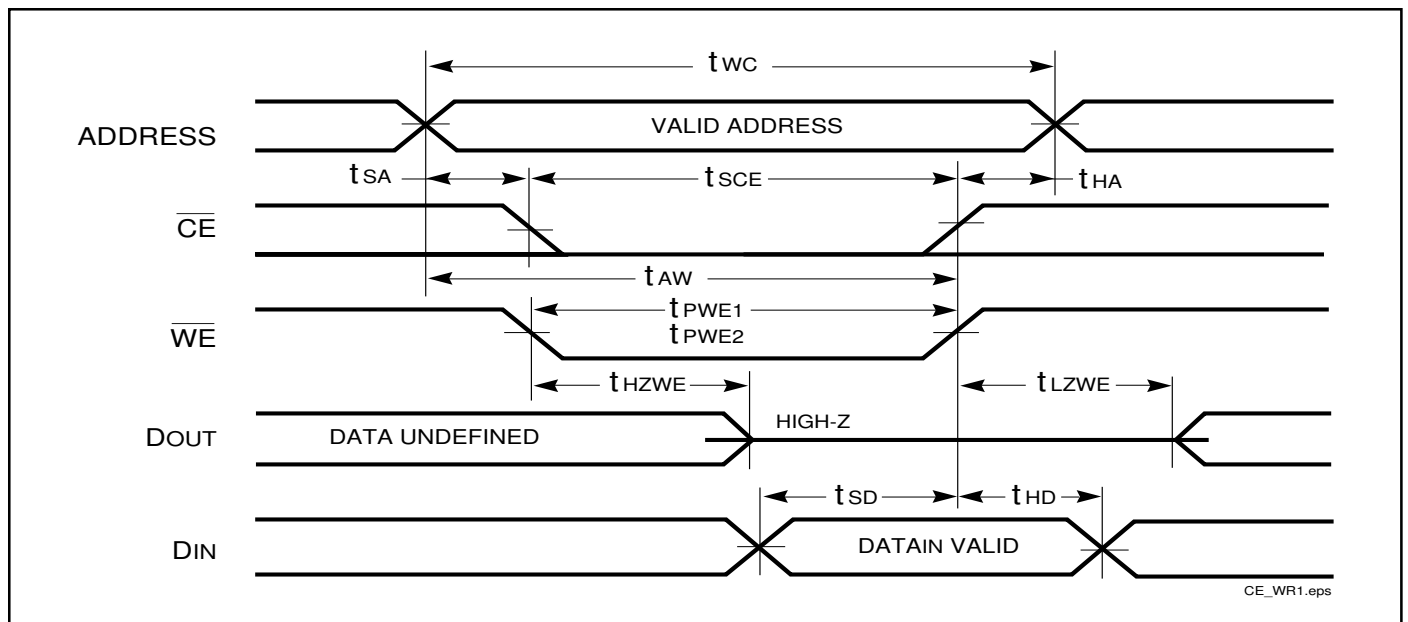

AC WAVEFORMS

WRITE CYCLE NO. 2⁽¹⁾ (\overline{WE} Controlled, \overline{OE} = HIGH during Write Cycle)

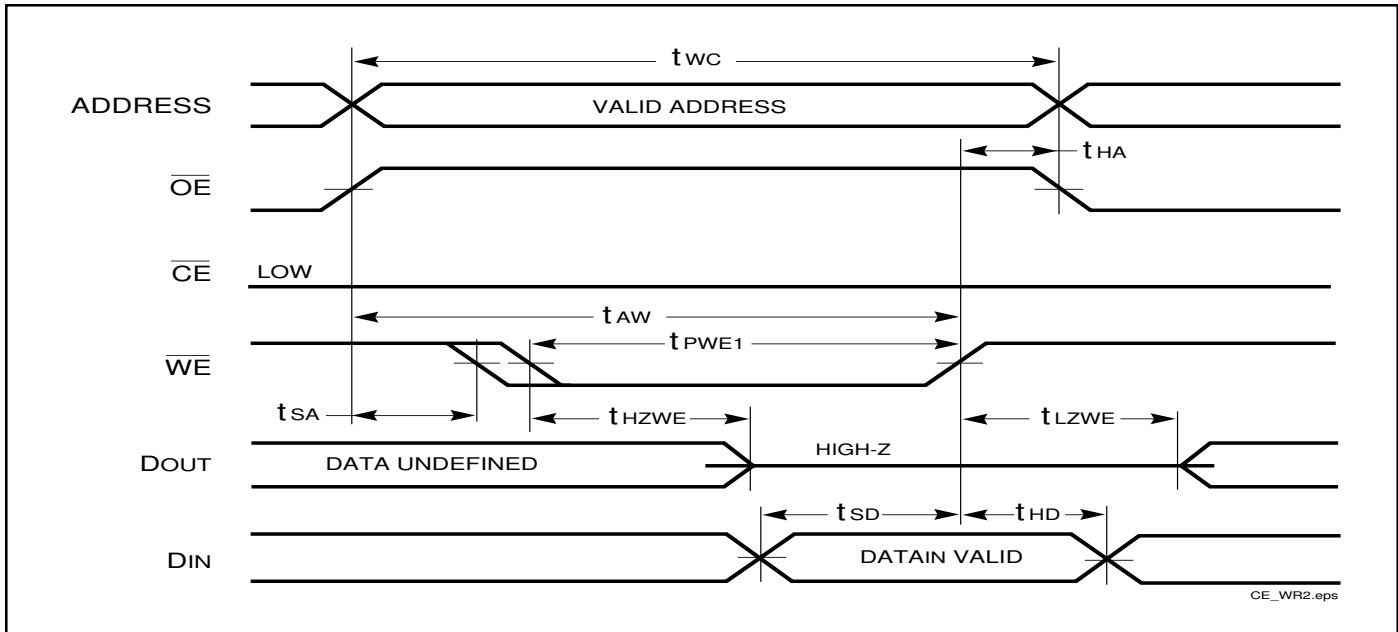

WRITE CYCLE NO. 3 (\overline{WE} Controlled: \overline{OE} is LOW During Write Cycle)

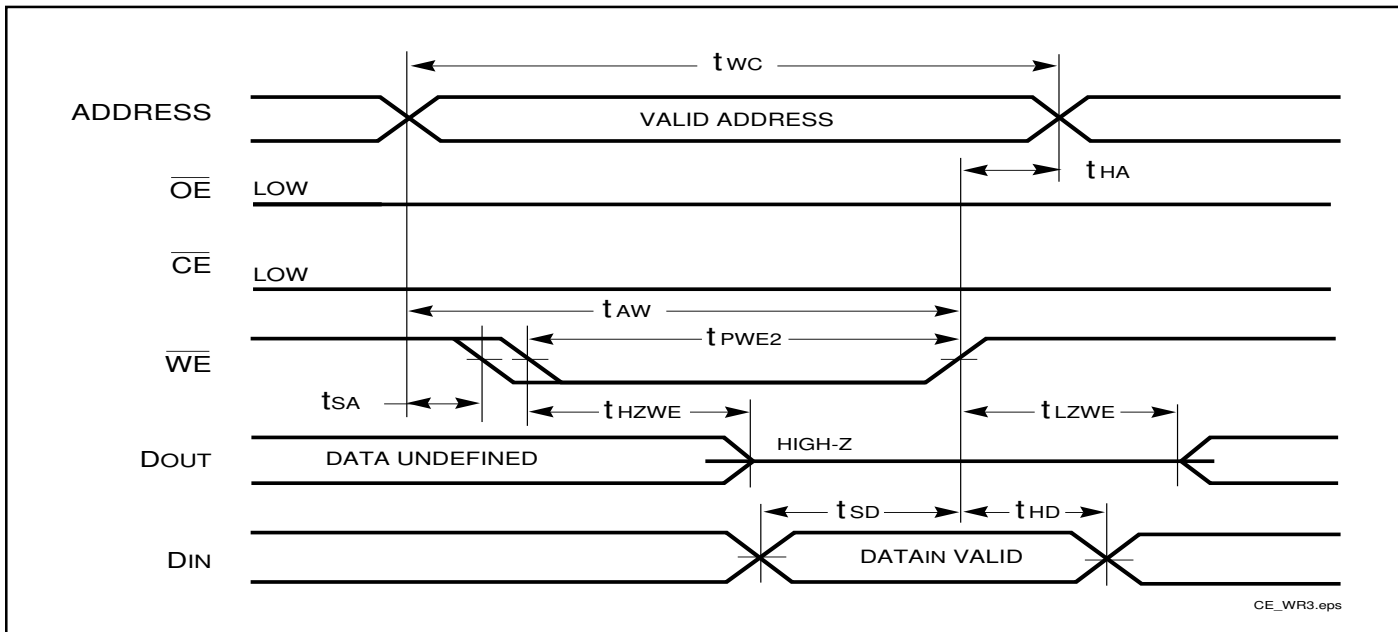

Notes:

1. The internal write time is defined by the overlap of \overline{CE} LOW and \overline{WE} LOW. All signals must be in valid states to initiate a Write, but any one can go inactive to terminate the Write. The Data Input Setup and Hold timing are referenced to the rising or falling edge of the signal that terminates the Write.
2. I/O will assume the High-Z state if $\overline{OE} > V_{IH}$.

DATA RETENTION SWITCHING CHARACTERISTICS

Symbol	Parameter	Test Condition	Operations	Min.	Typ. ⁽¹⁾	Max.	Unit
V _{DR}	V _{DD} for Data Retention	See Data Retention Waveform		1.8	—	3.6	V
I _{DR}	Data Retention Current	V _{DD} = 1.8V, $\overline{CE} \geq V_{DD} - 0.2V$	COM. IND. AUTO.	— — —	6 6 6	20 50 75	μA
t _{SDR}	Data Retention Setup Time	See Data Retention Waveform		0	—	—	ns
t _{RDR}	Recovery Time	See Data Retention Waveform		t _{RC}	—	—	ns

Note:

1. Typical values are measured at V_{DD} = 2.5V, T_A = 25°C. Not 100% tested.

DATA RETENTION WAVEFORM (\overline{CE} Controlled)

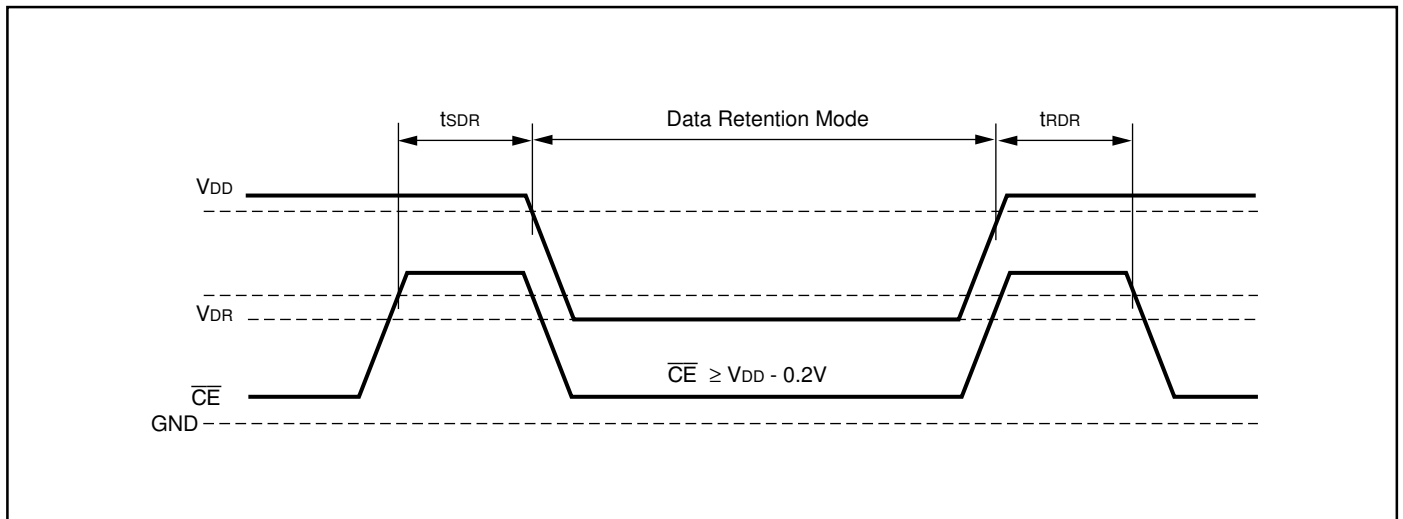

ORDERING INFORMATION

Industrial Range: -40°C to +85°C

Speed (ns)	Order Part No.	Package
12	IS63WV1024BLL-12TI	32-pin TSOP (Type II)
	IS63WV1024BLL-12TLI	32-pin TSOP (Type II), Lead-free
	IS63WV1024BLL-12HI	sTSOP (Type I) (8mm x13.4mm)
	IS63WV1024BLL-12HLI	sTSOP (Type I) (8mm x13.4mm), Lead-free
	IS63WV1024BLL-12JLI	32-pin SOJ (300-mil), Lead-free
	IS63WV1024BLL-12BI	mBGA(6mmx8mm)
	IS63WV1024BLL-12BLI	mBGA(6mmx8mm), Lead-free

Automotive Range (A3): -40°C to +85°C

Speed (ns)	Order Part No.	Package
15 (12*)	IS64WV1024BLL-15TA3	32-pin TSOP (Type II)
	IS64WV1024BLL-15TLA3	32-pin TSOP (Type II), Lead-free
	IS64WV1024BLL-15HA3	sTSOP (Type I) (8mm x13.4mm)
	IS64WV1024BLL-15HLA3	sTSOP (Type I) (8mm x13.4mm), Lead-free
	IS64WV1024BLL-15BA3	mBGA(6mmx8mm)
	IS64WV1024BLL-15BLA3	mBGA(6mmx8mm), Lead-free

Note:

1. Speed = 12ns for $V_{DD} = 3.3V \pm 10\%$. Speed = 15ns for $V_{DD} = 2.5V-3.6V$.

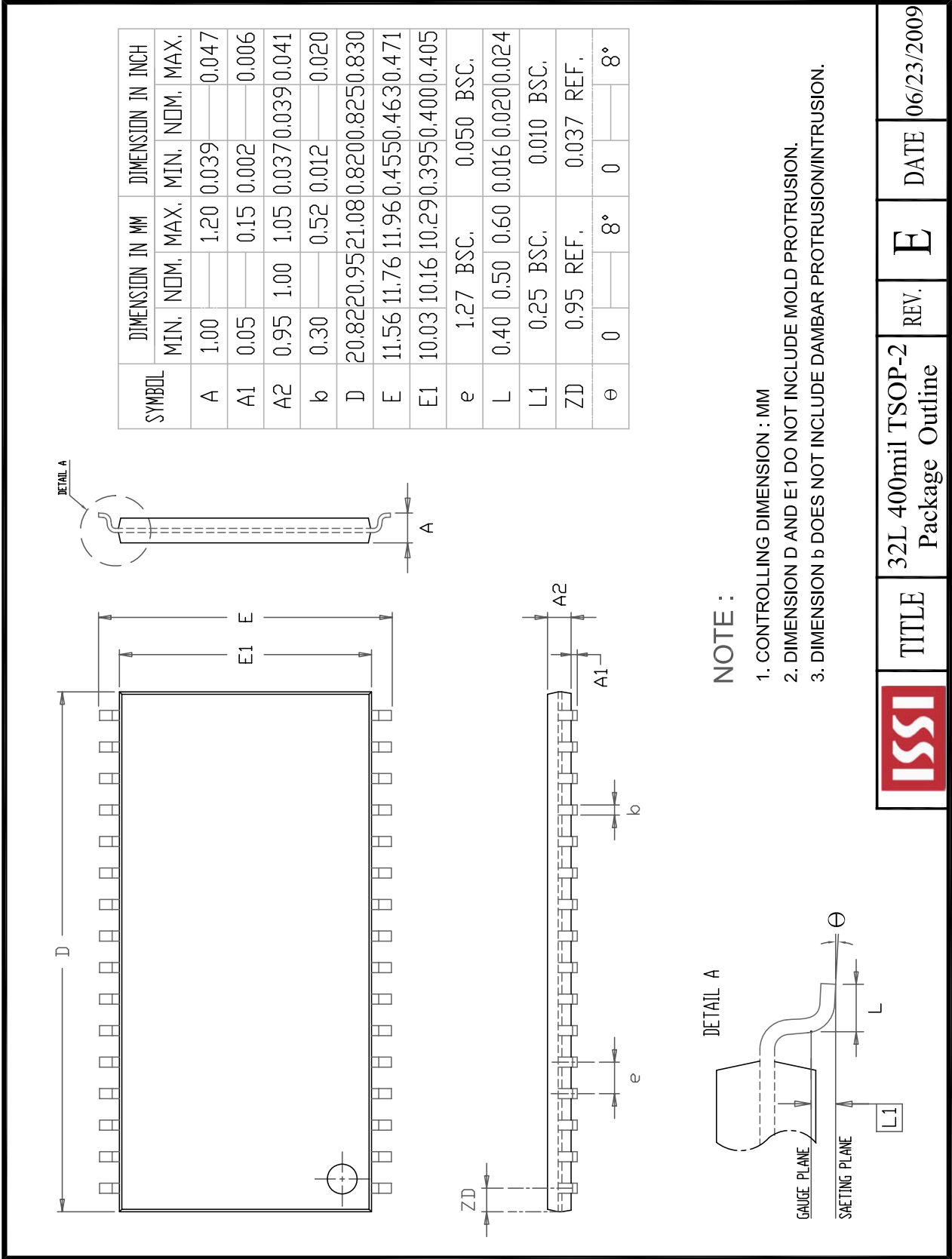

	TITLE	REV.	DATE
	32L 400mil TSOP-2 Package Outline	E	06/23/2009

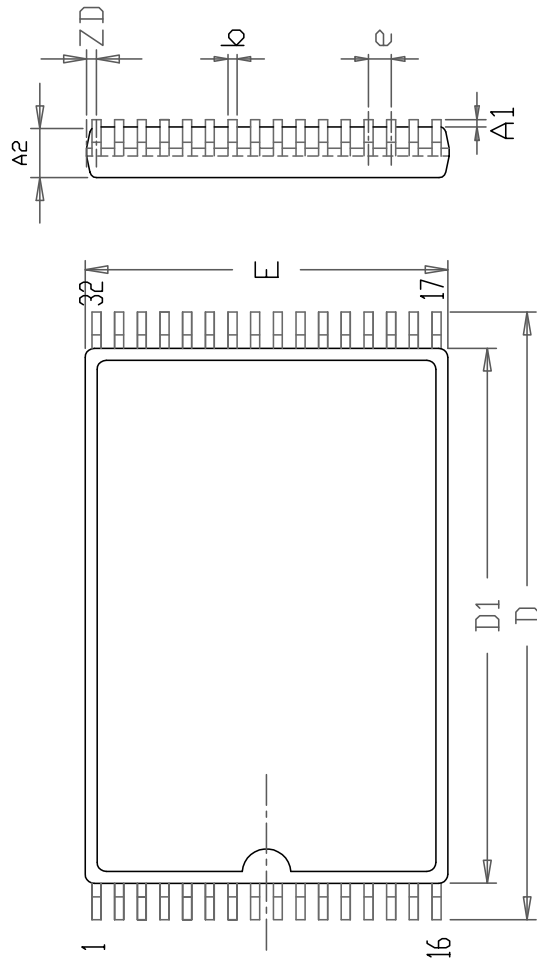

SYMBOL	DIMENSION IN MM			DIMENSION IN INCH		
	MIN	NOM	MAX	MIN	NOM	MAX
A	0.95		1.25	0.037		0.049
A1	0.05		0.15	0.002		0.008
A2	0.90		1.05	0.035		0.041
b	0.16		0.27	0.006		0.011
D	13.10	13.40	13.70	0.516	0.528	0.539
D1	11.70	11.80	11.90	0.461	0.465	0.469
E	7.90	8.00	8.10	0.311	0.315	0.319
e		0.50 BSC.			0.020 BSC.	
L	0.30	0.50	0.70	0.012	0.020	0.028
L1		0.25 BSC.			0.010 BSC.	
ZD		0.25 REF.			0.010 REF.	
Θ	0	3°	5°	0	3°	5°

NOTE :

1. CONTROLLING DIMENSION : MM
2. DIMENSION D1 AND E DO NOT INCLUDE MOLD PROTRUSION.
3. DIMENSION b DOES NOT INCLUDE DAMBAR PROTRUSION/INTRUSION.
4. Reference Document : JEDEC MO-183

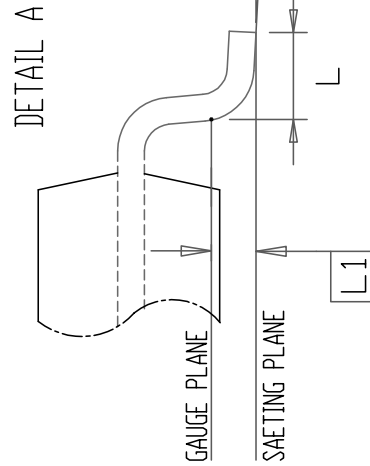
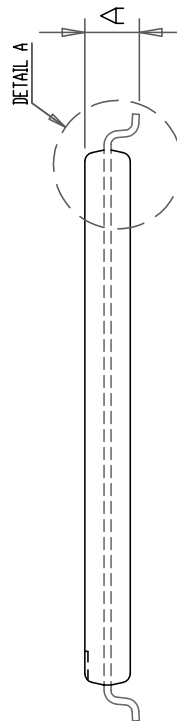

32L 8x13.4mm TSOP-1
Package Outline

TITLE

REV.

E

DATE

04/24/2009

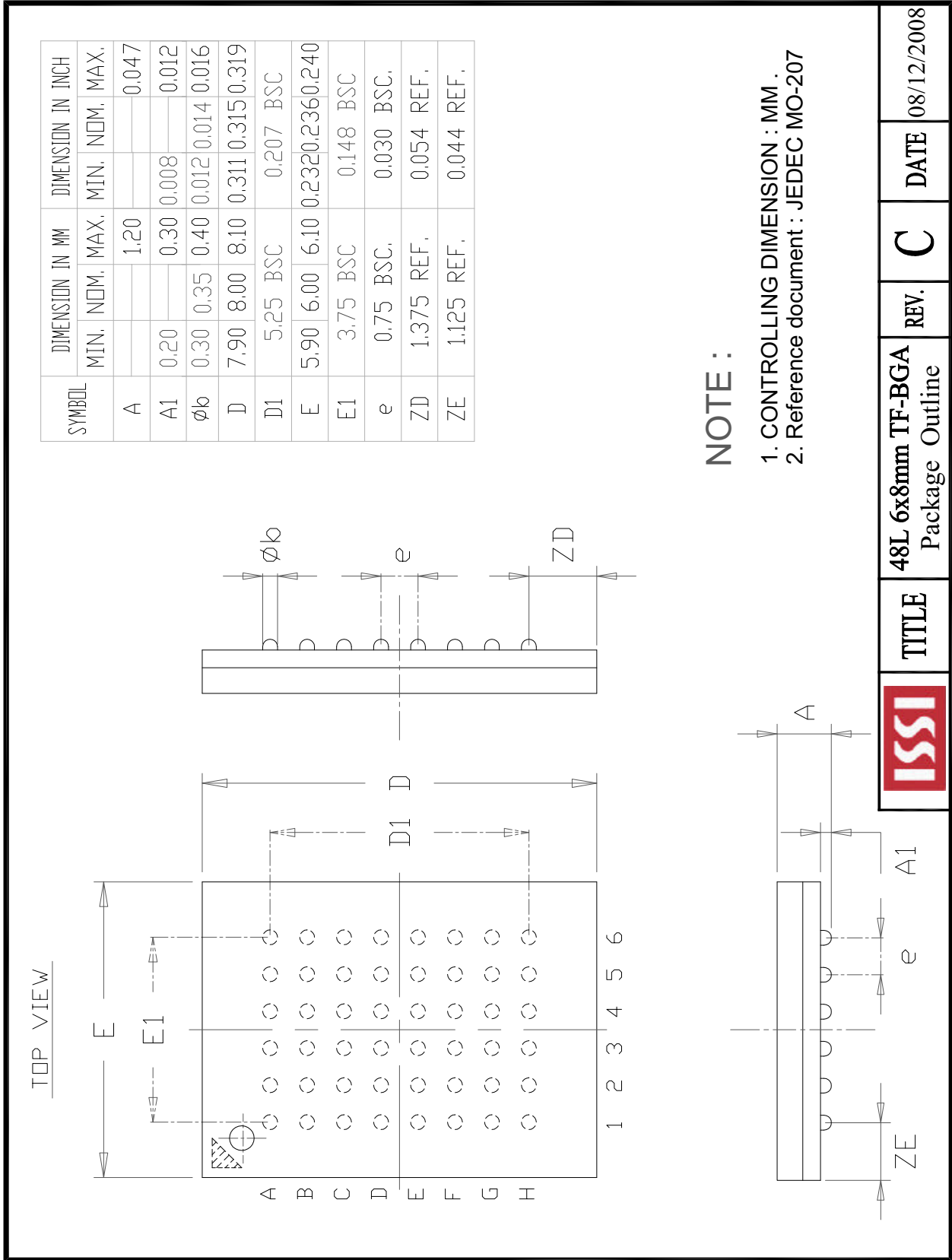

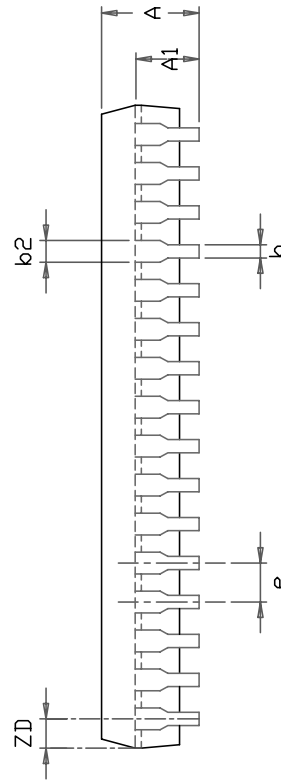
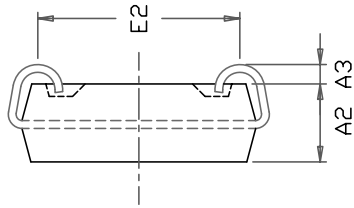
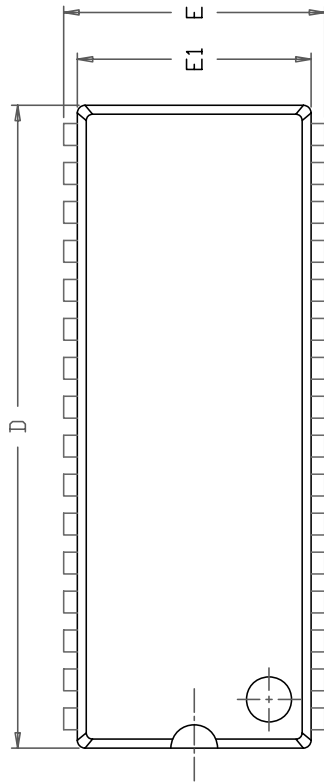

SYMBOL	DIMENSION IN MM		DIMENSION IN INCH	
	MIN.	NOM. MAX.	MIN.	NOM. MAX.
A	3.05	3.76	0.120	0.148
A1	2.08	2.41	0.082	0.095
A2	2.41	2.67	0.095	0.105
A3	0.64	1.09	0.025	0.043
b	0.41	0.51	0.016	0.020
b2	0.66	0.81	0.026	0.032
D	20.82	21.09	0.820	0.830
E	8.38	8.64	0.330	0.340
E1	7.49	7.75	0.295	0.305
E2	6.48	6.99	0.255	0.275
e	1.27	BSC.	0.050	BSC.
ZD	0.95	REF.	0.037	REF.

NOTE :

1. CONTROLLING DIMENSION : MM
2. DIMENSION D AND E1 DO NOT INCLUDE MOLD PROTRUSION.
3. DIMENSION b2 DOES NOT INCLUDE DAMBAR PROTRUSION/INTRUSION.



TITLE

32L 300mil SOJ
Package Outline

REV. C

DATE

08/14/2009

Looking for pricing, stock, or lifecycle information?

Click below to explore more details on WIN SOURCE:

- ⊖ [View IS63WV1024BLL-12TLI on WIN SOURCE](#)
- ⊖ [ISSI, Integrated Silicon Solution Inc Information](#)

Optimize Your Supply Chain with WIN SOURCE Solutions

- ✓ Global Sourcing Solution
- ✓ Obsolete Management
- ✓ Cost Control Management
- ✓ Shortage Management
- ✓ Alternative Solution
- ✓ Excess Inventory Management