





**1Mb x 36, 2Mb x 18**  
**36Mb SYNCHRONOUS PIPELINED,**  
**SINGLE CYCLE DESELECT STATIC RAM**

JUNE 2010

**FEATURES**

- Internal self-timed write cycle
- Individual Byte Write Control and Global Write
- Clock controlled, registered address, data and control
- Burst sequence control using MODE input
- Three chip enable option for simple depth expansion and address pipelining
- Common data inputs and data outputs
- Auto Power-down during deselect
- Single cycle deselect
- Snooze MODE for reduced-power standby
- Power Supply  
LPS:  $V_{DD} 3.3V \pm 5\%$ ,  $V_{DDQ} 3.3V/2.5V \pm 5\%$   
VPS:  $V_{DD} 2.5V \pm 5\%$ ,  $V_{DDQ} 2.5V \pm 5\%$
- JEDEC 100-Pin TQFP and 165-ball PBGA packages
- Lead-free available

**DESCRIPTION**

The *ISSI* IS61LPS/VPS102436A and IS61LPS/VPS204818A are high-speed, low-power synchronous static RAMs designed to provide burstable, high-performance memory for communication and networking applications. The IS61LPS/VPS102436A is organized as 1,048,476 words by 36 bits. The IS61LPS/VPS204818A is organized as 2M-word by 18 bits. Fabricated with *ISSI's* advanced CMOS technology, the device integrates a 2-bit burst counter, high-speed SRAM core, and high-drive capability outputs into a single monolithic circuit. All synchronous inputs pass through registers controlled by a positive-edge-triggered single clock input.

Write cycles are internally self-timed and are initiated by the rising edge of the clock input. Write cycles can be one to four bytes wide as controlled by the write control inputs.

Separate byte enables allow individual bytes to be written. The byte write operation is performed by using the byte write enable ( $\overline{BWE}$ ) input combined with one or more individual byte write signals ( $\overline{BWx}$ ). In addition, Global Write ( $\overline{GW}$ ) is available for writing all bytes at one time, regardless of the byte write controls.

Bursts can be initiated with either  $\overline{ADSP}$  (Address Status Processor) or  $\overline{ADSC}$  (Address Status Cache Controller) input pins. Subsequent burst addresses can be generated internally and controlled by the  $\overline{ADV}$  (burst address advance) input pin.

The mode pin is used to select the burst sequence order, Linear burst is achieved when this pin is tied LOW. Interleave burst is achieved when this pin is tied HIGH or left floating.

**FAST ACCESS TIME**

Symbol	Parameter	200	166	Units
tkQ	Clock Access Time	3.1	3.5	ns
tkC	Cycle Time	5	6	ns
	Frequency	200	166	MHz

Copyright © 2010 Integrated Silicon Solution, Inc. All rights reserved. ISSI reserves the right to make changes to this specification and its products at any time without notice. ISSI assumes no liability arising out of the application or use of any information, products or services described herein. Customers are advised to obtain the latest version of this device specification before relying on any published information and before placing orders for products.

Integrated Silicon Solution, Inc. does not recommend the use of any of its products in life support applications where the failure or malfunction of the product can reasonably be expected to cause failure of the life support system or to significantly affect its safety or effectiveness. Products are not authorized for use in such applications unless Integrated Silicon Solution, Inc. receives written assurance to its satisfaction, that:

- a.) the risk of injury or damage has been minimized;
- b.) the user assume all such risks; and
- c.) potential liability of Integrated Silicon Solution, Inc is adequately protected under the circumstances

**BLOCK DIAGRAM**

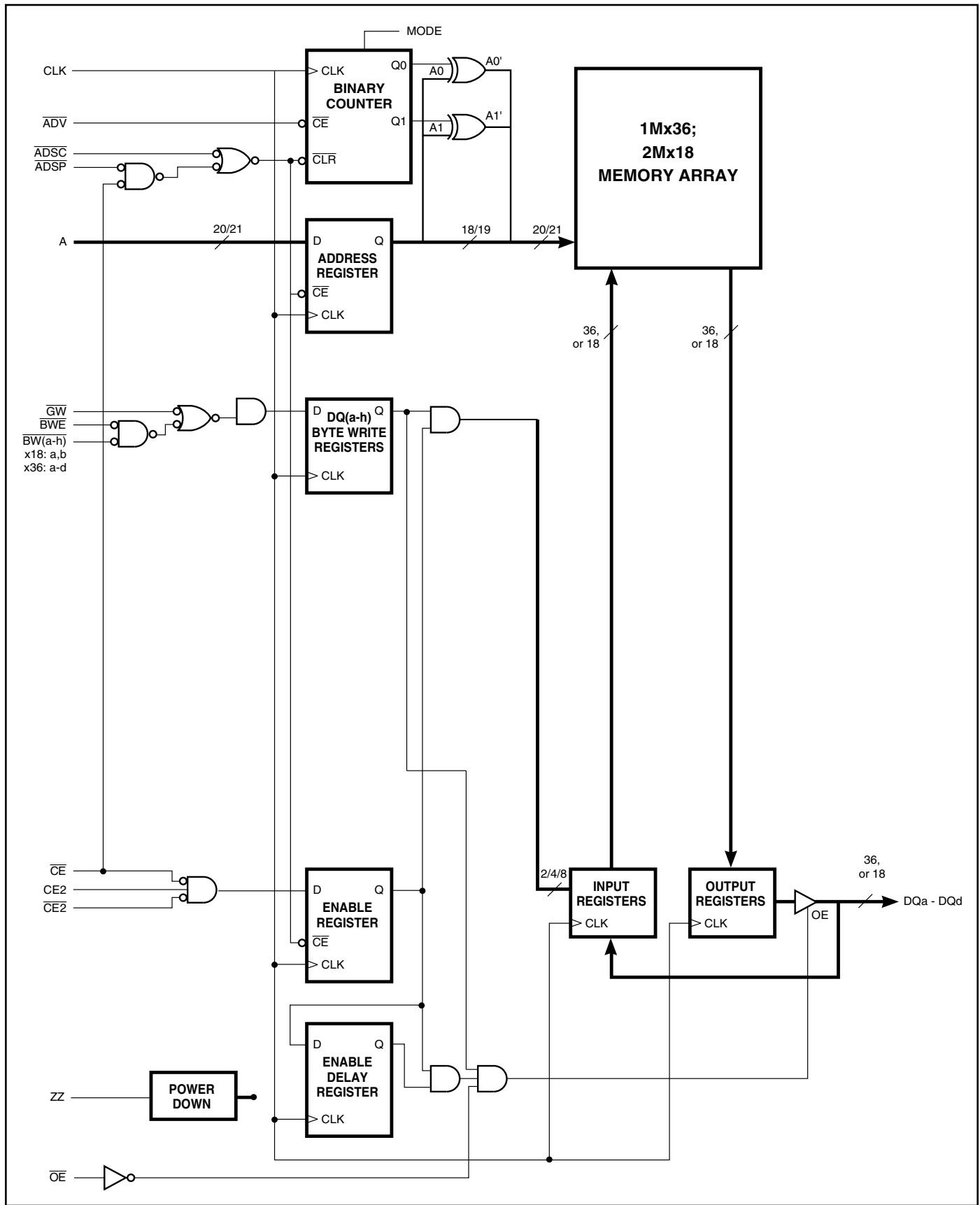

**165-PIN BGA**

165-Ball, 13x15 mm BGA  
1mm Ball Pitch, 11x15 Ball Array

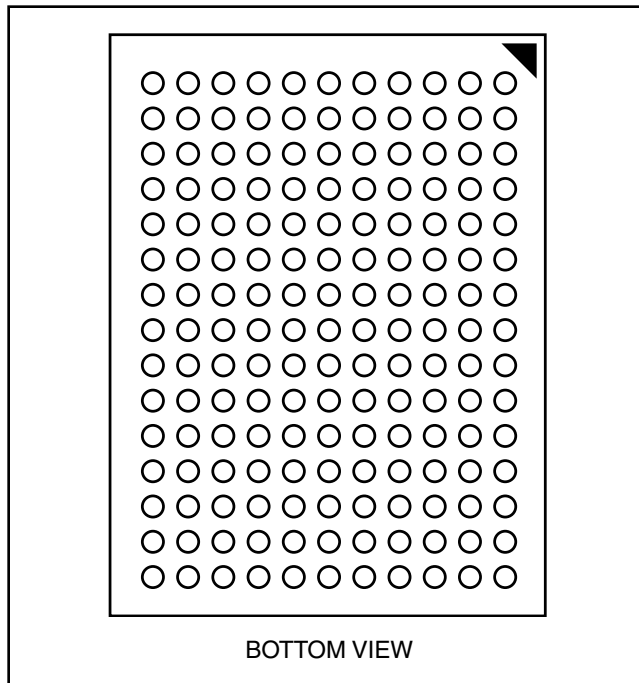

## 165 PBGA PACKAGE PIN CONFIGURATION

1M x 36 (TOP VIEW)

	1	2	3	4	5	6	7	8	9	10	11
<b>A</b>	NC	A	$\overline{CE}$	$\overline{BWc}$	$\overline{BWb}$	$\overline{CE2}$	$\overline{BWE}$	$\overline{ADSC}$	$\overline{ADV}$	A	NC
<b>B</b>	NC	A	CE2	$\overline{BWd}$	$\overline{BWa}$	CLK	$\overline{GW}$	$\overline{OE}$	$\overline{ADSP}$	A	NC
<b>C</b>	DQPc	NC	VDDQ	Vss	Vss	Vss	Vss	Vss	VDDQ	NC	DQPb
<b>D</b>	DQc	DQc	VDDQ	VDD	Vss	Vss	Vss	VDD	VDDQ	DQb	DQb
<b>E</b>	DQc	DQc	VDDQ	VDD	Vss	Vss	Vss	VDD	VDDQ	DQb	DQb
<b>F</b>	DQc	DQc	VDDQ	VDD	Vss	Vss	Vss	VDD	VDDQ	DQb	DQb
<b>G</b>	DQc	DQc	VDDQ	VDD	Vss	Vss	Vss	VDD	VDDQ	DQb	DQb
<b>H</b>	NC	NC	NC	VDD	Vss	Vss	Vss	VDD	NC	NC	ZZ
<b>J</b>	DQd	DQd	VDDQ	VDD	Vss	Vss	Vss	VDD	VDDQ	DQa	DQa
<b>K</b>	DQd	DQd	VDDQ	VDD	Vss	Vss	Vss	VDD	VDDQ	DQa	DQa
<b>L</b>	DQd	DQd	VDDQ	VDD	Vss	Vss	Vss	VDD	VDDQ	DQa	DQa
<b>M</b>	DQd	DQd	VDDQ	VDD	Vss	Vss	Vss	VDD	VDDQ	DQa	DQa
<b>N</b>	DQPd	NC	VDDQ	Vss	NC	A	NC	Vss	VDDQ	NC	DQPd
<b>P</b>	NC	NC	A	A	NC	A1*	NC	A	A	A	A
<b>R</b>	MODE	A	A	A	NC	A0*	NC	A	A	A	A

**Note:** \* A0 and A1 are the two least significant bits (LSB) of the address field and set the internal burst counter if burst is desired.

## PIN DESCRIPTIONS

Symbol	Pin Name
A	Address Inputs
A0, A1	Synchronous Burst Address Inputs
$\overline{ADV}$	Synchronous Burst Address Advance
$\overline{ADSP}$	Address Status Processor
$\overline{ADSC}$	Address Status Controller
$\overline{GW}$	Global Write Enable
CLK	Synchronous Clock
$\overline{CE}$ , $\overline{CE2}$ , CE2	Synchronous Chip Select
$\overline{BWx}$ (x=a,b,c,d)	Synchronous Byte Write Controls

Symbol	Pin Name
$\overline{BWE}$	Byte Write Enable
$\overline{OE}$	Output Enable
ZZ	Power Sleep Mode
MODE	Burst Sequence Selection
NC	No Connect
DQx	Data Inputs/Outputs
DQPx	Data Inputs/Outputs
VDD	3.3V/2.5V Power Supply
VDDQ	Isolated Output Power Supply 3.3V/2.5V
Vss	Ground

**165 PBGA PACKAGE PIN CONFIGURATION**

2M x 18 (TOP VIEW)

	1	2	3	4	5	6	7	8	9	10	11
<b>A</b>	NC	A	$\overline{CE}$	$\overline{BWb}$	NC	$\overline{CE2}$	$\overline{BWE}$	$\overline{ADSC}$	$\overline{ADV}$	A	A
<b>B</b>	NC	A	CE2	NC	$\overline{BWA}$	CLK	$\overline{GW}$	$\overline{OE}$	$\overline{ADSP}$	A	NC
<b>C</b>	NC	NC	V <sub>DDQ</sub>	V <sub>SS</sub>	V <sub>SS</sub>	V <sub>SS</sub>	V <sub>SS</sub>	V <sub>SS</sub>	V <sub>DDQ</sub>	NC	DQP <sub>a</sub>
<b>D</b>	NC	DQ <sub>b</sub>	V <sub>DDQ</sub>	V <sub>DD</sub>	V <sub>SS</sub>	V <sub>SS</sub>	V <sub>SS</sub>	V <sub>DD</sub>	V <sub>DDQ</sub>	NC	DQ <sub>a</sub>
<b>E</b>	NC	DQ <sub>b</sub>	V <sub>DDQ</sub>	V <sub>DD</sub>	V <sub>SS</sub>	V <sub>SS</sub>	V <sub>SS</sub>	V <sub>DD</sub>	V <sub>DDQ</sub>	NC	DQ <sub>a</sub>
<b>F</b>	NC	DQ <sub>b</sub>	V <sub>DDQ</sub>	V <sub>DD</sub>	V <sub>SS</sub>	V <sub>SS</sub>	V <sub>SS</sub>	V <sub>DD</sub>	V <sub>DDQ</sub>	NC	DQ <sub>a</sub>
<b>G</b>	NC	DQ <sub>b</sub>	V <sub>DDQ</sub>	V <sub>DD</sub>	V <sub>SS</sub>	V <sub>SS</sub>	V <sub>SS</sub>	V <sub>DD</sub>	V <sub>DDQ</sub>	NC	DQ <sub>a</sub>
<b>H</b>	NC	NC	NC	V <sub>DD</sub>	V <sub>SS</sub>	V <sub>SS</sub>	V <sub>SS</sub>	V <sub>DD</sub>	NC	NC	ZZ
<b>J</b>	DQ <sub>b</sub>	NC	V <sub>DDQ</sub>	V <sub>DD</sub>	V <sub>SS</sub>	V <sub>SS</sub>	V <sub>SS</sub>	V <sub>DD</sub>	V <sub>DDQ</sub>	DQ <sub>a</sub>	NC
<b>K</b>	DQ <sub>b</sub>	NC	V <sub>DDQ</sub>	V <sub>DD</sub>	V <sub>SS</sub>	V <sub>SS</sub>	V <sub>SS</sub>	V <sub>DD</sub>	V <sub>DDQ</sub>	DQ <sub>a</sub>	NC
<b>L</b>	DQ <sub>b</sub>	NC	V <sub>DDQ</sub>	V <sub>DD</sub>	V <sub>SS</sub>	V <sub>SS</sub>	V <sub>SS</sub>	V <sub>DD</sub>	V <sub>DDQ</sub>	DQ <sub>a</sub>	NC
<b>M</b>	DQ <sub>b</sub>	NC	V <sub>DDQ</sub>	V <sub>DD</sub>	V <sub>SS</sub>	V <sub>SS</sub>	V <sub>SS</sub>	V <sub>DD</sub>	V <sub>DDQ</sub>	DQ <sub>a</sub>	NC
<b>N</b>	DQP <sub>b</sub>	NC	V <sub>DDQ</sub>	V <sub>SS</sub>	NC	A	NC	V <sub>SS</sub>	V <sub>DDQ</sub>	NC	NC
<b>P</b>	NC	NC	A	A	NC	A1*	NC	A	A	A	A
<b>R</b>	MODE	A	A	A	NC	A0*	NC	A	A	A	A

**Note:** \* A<sub>0</sub> and A<sub>1</sub> are the two least significant bits (LSB) of the address field and set the internal burst counter if burst is desired.

**PIN DESCRIPTIONS**

Symbol	Pin Name
A	Address Inputs
A0, A1	Synchronous Burst Address Inputs
$\overline{ADV}$	Synchronous Burst Address Advance
$\overline{ADSP}$	Address Status Processor
$\overline{ADSC}$	Address Status Controller
$\overline{GW}$	Global Write Enable
CLK	Synchronous Clock
$\overline{CE}$ , $\overline{CE2}$ , CE2	Synchronous Chip Select
$\overline{BWx}$ (x=a,b)	Synchronous Byte Write Controls

Symbol	Pin Name
$\overline{BWE}$	Byte Write Enable
$\overline{OE}$	Output Enable
ZZ	Power Sleep Mode
MODE	Burst Sequence Selection
NC	No Connect
DQ <sub>x</sub>	Data Inputs/Outputs
DQP <sub>x</sub>	Data Inputs/Outputs
V <sub>DD</sub>	3.3V/2.5V Power Supply
V <sub>DDQ</sub>	Isolated Output Power Supply 3.3V/2.5V
V <sub>SS</sub>	Ground



## PIN CONFIGURATION

### 100-PIN TQFP

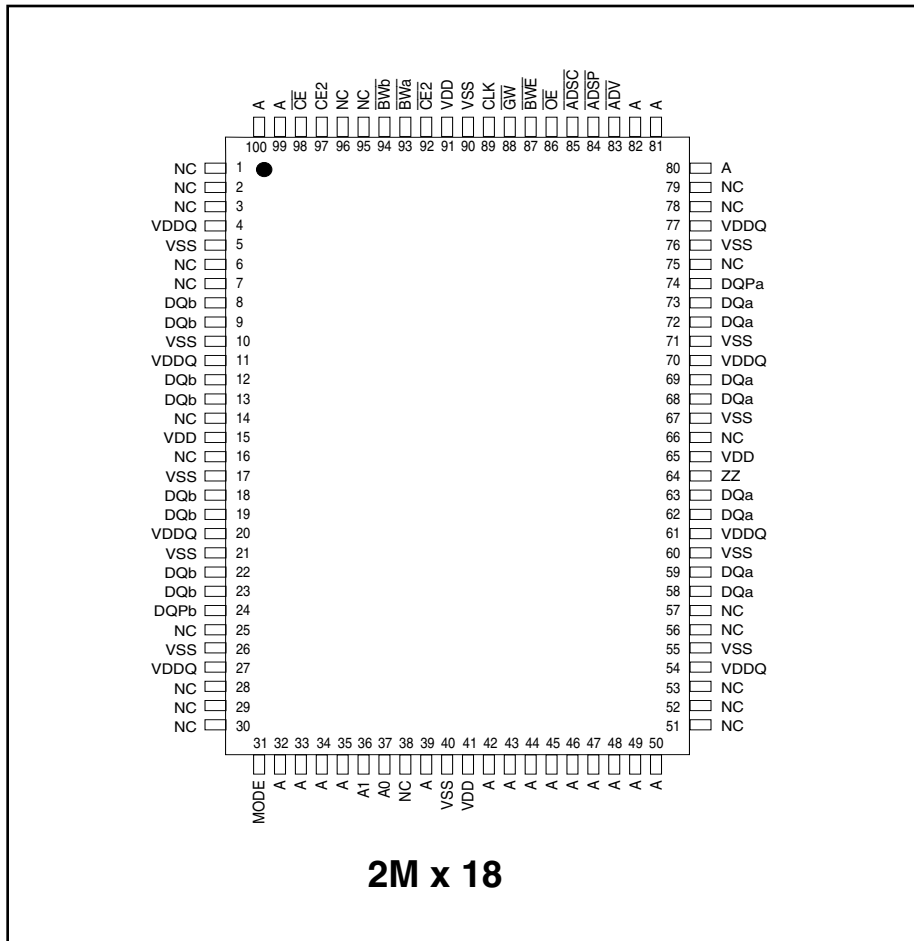

## PIN DESCRIPTIONS

A0, A1	Synchronous Address Inputs. These pins must be tied to the two LSBs of the address bus.	DQPa-DQPb	Parity Data I/O; DQPa is parity for DQa1-8; DQPb is parity for DQb1-8
A	Synchronous Address Inputs	$\overline{GW}$	Synchronous Global Write Enable
$\overline{ADSC}$	Synchronous Controller Address Status	MODE	Burst Sequence Mode Selection
$\overline{ADSP}$	Synchronous Processor Address Status	$\overline{OE}$	Output Enable
$\overline{ADV}$	Synchronous Burst Address Advance	VDD	3.3V/2.5V Power Supply
$\overline{BWA-BWB}$	Synchronous Byte Write Enable	VDDQ	Isolated Output Buffer Supply: 3.3V/2.5V
$\overline{BWE}$	Synchronous Byte Write Enable	VSS	Ground
$\overline{CE}, \overline{CE2}, \overline{CE2}$	Synchronous Chip Enable	ZZ	Snooze Enable
CLK	Synchronous Clock		
DQa-DQb	Synchronous Data Input/Output		

TRUTH TABLE<sup>(1-8)</sup> (3CE option)

OPERATION	ADDRESS	$\overline{CE}$	$\overline{CE2}$	CE2	ZZ	$\overline{ADSP}$	$\overline{ADSC}$	$\overline{ADV}$	$\overline{WRITE}$	$\overline{OE}$	CLK	DQ
Deselect Cycle, Power-Down	None	H	X	X	L	X	L	X	X	X	L-H	High-Z
Deselect Cycle, Power-Down	None	L	X	L	L	L	X	X	X	X	L-H	High-Z
Deselect Cycle, Power-Down	None	L	H	X	L	L	X	X	X	X	L-H	High-Z
Deselect Cycle, Power-Down	None	L	X	L	L	H	L	X	X	X	L-H	High-Z
Deselect Cycle, Power-Down	None	L	H	X	L	H	L	X	X	X	L-H	High-Z
Snooze Mode, Power-Down	None	X	X	X	H	X	X	X	X	X	X	High-Z
Read Cycle, Begin Burst	External	L	L	H	L	L	X	X	X	L	L-H	Q
Read Cycle, Begin Burst	External	L	L	H	L	L	X	X	X	H	L-H	High-Z
Write Cycle, Begin Burst	External	L	L	H	L	H	L	X	L	X	L-H	D
Read Cycle, Begin Burst	External	L	L	H	L	H	L	X	H	L	L-H	Q
Read Cycle, Begin Burst	External	L	L	H	L	H	L	X	H	H	L-H	High-Z
Read Cycle, Continue Burst	Next	X	X	X	L	H	H	L	H	L	L-H	Q
Read Cycle, Continue Burst	Next	X	X	X	L	H	H	L	H	H	L-H	High-Z
Read Cycle, Continue Burst	Next	H	X	X	L	X	H	L	H	L	L-H	Q
Read Cycle, Continue Burst	Next	H	X	X	L	X	H	L	H	H	L-H	High-Z
Write Cycle, Continue Burst	Next	X	X	X	L	H	H	L	L	X	L-H	D
Write Cycle, Continue Burst	Next	H	X	X	L	X	H	L	L	X	L-H	D
Read Cycle, Suspend Burst	Current	X	X	X	L	H	H	H	H	L	L-H	Q
Read Cycle, Suspend Burst	Current	X	X	X	L	H	H	H	H	H	L-H	High-Z
Read Cycle, Suspend Burst	Current	H	X	X	L	X	H	H	H	L	L-H	Q
Read Cycle, Suspend Burst	Current	H	X	X	L	X	H	H	H	H	L-H	High-Z
Write Cycle, Suspend Burst	Current	X	X	X	L	H	H	H	L	X	L-H	D
Write Cycle, Suspend Burst	Current	H	X	X	L	X	H	H	L	X	L-H	D

## NOTE:

1. X means "Don't Care." H means logic HIGH. L means logic LOW.
2. For  $\overline{WRITE}$ , L means one or more byte write enable signals ( $\overline{BWA-h}$ ) and  $\overline{BWE}$  are LOW or  $\overline{GW}$  is LOW.  $\overline{WRITE} = H$  for all  $\overline{BWx}$ ,  $\overline{BWE}$ ,  $\overline{GW}$  HIGH.
3.  $\overline{BWA}$  enables WRITES to DQa's and DQPa.  $\overline{BWB}$  enables WRITES to DQb's and DQPb.  $\overline{BWC}$  enables WRITES to DQc's and DQPc.  $\overline{BWD}$  enables WRITES to DQd's and DQPd. DQPa-DQPd are available on the x36 version.
4. All inputs except  $\overline{OE}$  and ZZ must meet setup and hold times around the rising edge (LOW to HIGH) of CLK.
5. Wait states are inserted by suspending burst.
6. For a WRITE operation following a READ operation,  $\overline{OE}$  must be HIGH before the input data setup time and held HIGH during the input data hold time.
7. This device contains circuitry that will ensure the outputs will be in High-Z during power-up.
8.  $\overline{ADSP}$  LOW always initiates an internal READ at the L-H edge of CLK. A WRITE is performed by setting one or more byte write enable signals and  $\overline{BWE}$  LOW or  $\overline{GW}$  LOW for the subsequent L-H edge of CLK. See WRITE timing diagram for clarification.

**TRUTH TABLE<sup>(1-8)</sup> (1CE option)**

NEXT CYCLE	ADDRESS	$\overline{OE}$	$\overline{ADSP}$	$\overline{ADSC}$	$\overline{ADV}$	WRITE	$\overline{OE}$	DQ
Deselected	None	H	X	L	X	X	X	High-Z
Read, Begin Burst	External	L	L	X	X	X	L	Q
Read, Begin Burst	External	L	L	X	X	X	H	High-Z
Write, Begin Burst	External	L	H	L	X	L	X	D
Read, Begin Burst	External	L	H	L	X	H	L	Q
Read, Begin Burst	External	L	H	L	X	H	H	High-Z
Read, Continue Burst	Next	X	H	H	L	H	L	Q
Read, Continue Burst	Next	X	H	H	L	H	H	High-Z
Read, Continue Burst	Next	H	X	H	L	H	L	Q
Read, Continue Burst	Next	H	X	H	L	H	H	High-Z
Write, Continue Burst	Next	X	H	H	L	L	X	D
Write, Continue Burst	Next	H	X	H	L	L	X	D
Read, Suspend Burst	Current	X	H	H	H	H	L	Q
Read, Suspend Burst	Current	X	H	H	H	H	H	High-Z
Read, Suspend Burst	Current	H	X	H	H	H	L	Q
Read, Suspend Burst	Current	H	X	H	H	H	H	High-Z
Write, Suspend Burst	Current	X	H	H	H	L	X	D
Write, Suspend Burst	Current	H	X	H	H	L	X	D

**NOTE:**

1. X means "Don't Care." H means logic HIGH. L means logic LOW.
2. For WRITE, L means one or more byte write enable signals ( $\overline{BWA-h}$ ) and  $\overline{BWE}$  are LOW or  $\overline{GW}$  is LOW.  $\overline{WRITE} = H$  for all  $\overline{BWx}$ ,  $\overline{BWE}$ ,  $\overline{GW}$  HIGH.
3.  $\overline{BWA}$  enables WRITES to DQa's and DQPa.  $\overline{BWB}$  enables WRITES to DQb's and DQPb.  $\overline{BWC}$  enables WRITES to DQc's and DQPc.  $\overline{BWD}$  enables WRITES to DQd's and DQPd. DQPa-DQPd are available on the x36 version.
4. All inputs except  $\overline{OE}$  and ZZ must meet setup and hold times around the rising edge (LOW to HIGH) of CLK.
5. Wait states are inserted by suspending burst.
6. For a WRITE operation following a READ operation,  $\overline{OE}$  must be HIGH before the input data setup time and held HIGH during the input data hold time.
7. This device contains circuitry that will ensure the outputs will be in High-Z during power-up.
8.  $\overline{ADSP}$  LOW always initiates an internal READ at the L-H edge of CLK. A WRITE is performed by setting one or more byte write enable signals and  $\overline{BWE}$  LOW or  $\overline{GW}$  LOW for the subsequent L-H edge of CLK. See WRITE timing diagram for clarification.

**PARTIAL TRUTH TABLE**

Function	$\overline{GW}$	$\overline{BWE}$	$\overline{BWA}$	$\overline{BWB}$	$\overline{BWC}$	$\overline{BWD}$
Read	H	H	X	X	X	X
Read	H	L	H	H	H	H
Write Byte 1	H	L	L	H	H	H
Write All Bytes	H	L	L	L	L	L
Write All Bytes	L	X	X	X	X	X

**INTERLEAVED BURST ADDRESS TABLE (MODE = V<sub>DD</sub> or No Connect)**

External Address A1 A0	1st Burst Address A1 A0	2nd Burst Address A1 A0	3rd Burst Address A1 A0
00	01	10	11
01	00	11	10
10	11	00	01
11	10	01	00

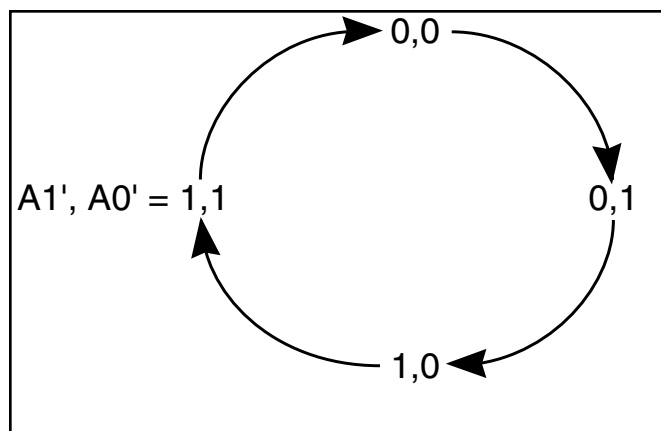
**LINEAR BURST ADDRESS TABLE (MODE = V<sub>SS</sub>)**

**ABSOLUTE MAXIMUM RATINGS<sup>(1)</sup>**

Symbol	Parameter	Value	Unit
T <sub>STG</sub>	Storage Temperature	-55 to +150	°C
P <sub>D</sub>	Power Dissipation	1.6	W
I <sub>OUT</sub>	Output Current (per I/O)	100	mA
V <sub>IN</sub> , V <sub>OUT</sub>	Voltage Relative to V <sub>SS</sub> for I/O Pins	-0.5 to V <sub>DDQ</sub> + 0.5	V
V <sub>IN</sub>	Voltage Relative to V <sub>SS</sub> for for Address and Control Inputs	-0.5 to V <sub>DD</sub> + 0.5	V
V <sub>DD</sub>	Voltage on V <sub>DD</sub> Supply Relative to V <sub>SS</sub>	-0.5 to 4.6	V

**Notes:**

1. Stress greater than those listed under ABSOLUTE MAXIMUM RATINGS may cause permanent damage to the device. This is a stress rating only and functional operation of the device at these or any other conditions above those indicated in the operational sections of this specification is not implied. Exposure to absolute maximum rating conditions for extended periods may affect reliability.
2. This device contains circuitry to protect the inputs against damage due to high static voltages or electric fields; however, precautions may be taken to avoid application of any voltage higher than maximum rated voltages to this high-impedance circuit.
3. This device contains circuitry that will ensure the output devices are in High-Z at power up.

**OPERATING RANGE (IS61LPSXXXXX)**

Range	Ambient Temperature	V <sub>DD</sub>	V <sub>DDQ</sub>
Commercial	0°C to +70°C	3.3V ± 5%	3.3V / 2.5V ± 5%
Industrial	-40°C to +85°C	3.3V ± 5%	3.3V / 2.5V ± 5%

**OPERATING RANGE (IS61VPSXXXXX)**

Range	Ambient Temperature	V <sub>DD</sub>	V <sub>DDQ</sub>
Commercial	0°C to +70°C	2.5V ± 5%	2.5V ± 5%
Industrial	-40°C to +85°C	2.5V ± 5%	2.5V ± 5%

**DC ELECTRICAL CHARACTERISTICS (Over Operating Range)**

Symbol	Parameter	Test Conditions	3.3V		2.5V		Unit
			Min.	Max.	Min.	Max.	
V <sub>OH</sub>	Output HIGH Voltage	I <sub>OH</sub> = -4.0 mA (3.3V) I <sub>OH</sub> = -1.0 mA (2.5V)	2.4	—	2.0	—	V
V <sub>OL</sub>	Output LOW Voltage	I <sub>OL</sub> = 8.0 mA (3.3V) I <sub>OL</sub> = 1.0 mA (2.5V)	—	0.4	—	0.4	V
V <sub>IH</sub>	Input HIGH Voltage		2.0	V <sub>DD</sub> + 0.3	1.7	V <sub>DD</sub> + 0.3	V
V <sub>IL</sub>	Input LOW Voltage		-0.3	0.8	-0.3	0.7	V
I <sub>LI</sub>	Input Leakage Current	V <sub>SS</sub> ≤ V <sub>IN</sub> ≤ V <sub>DD</sub> <sup>(1)</sup>	-5	5	-5	5	μA
I <sub>LO</sub>	Output Leakage Current	V <sub>SS</sub> ≤ V <sub>OUT</sub> ≤ V <sub>DDQ</sub> , OE = V <sub>IH</sub>	-5	5	-5	5	μA

**POWER SUPPLY CHARACTERISTICS<sup>(1)</sup> (Over Operating Range)**

Symbol	Parameter	Test Conditions	Temp. range	-200 MAX		-166 MAX		Unit
				x18	x36	x18	x36	
I <sub>CC</sub>	AC Operating Supply Current	Device Selected, OE = V <sub>IH</sub> , ZZ ≤ V <sub>IL</sub> , All Inputs ≤ 0.2V or ≥ V <sub>DD</sub> - 0.2V, Cycle Time ≥ t <sub>kc</sub> min.	Com. Ind. typ. <sup>(2)</sup>	450 475 390	450 475	400 450 340	400 450	mA
I <sub>SB</sub>	Standby Current TTL Input	Device Deselected, V <sub>DD</sub> = Max., All Inputs ≤ V <sub>IL</sub> or ≥ V <sub>IH</sub> , ZZ ≤ V <sub>IL</sub> , f = Max.	Com. Ind.	150 160	150 160	140 150	140 150	mA
I <sub>SBI</sub>	Standby Current CMOS Input	Device Deselected, V <sub>DD</sub> = Max., V <sub>IN</sub> ≤ V <sub>SS</sub> + 0.2V or ≥ V <sub>DD</sub> - 0.2V f = 0	Com. Ind. typ. <sup>(2)</sup>	110 140 75	110 140	110 140 75	110 140	mA

**Note:**

- MODE pin has an internal pullup and should be tied to V<sub>DD</sub> or V<sub>SS</sub>. It exhibits ±100μA maximum leakage current when tied to ≤ V<sub>SS</sub> + 0.2V or ≥ V<sub>DD</sub> - 0.2V.
- Typical values are measured at V<sub>CC</sub> = 3.3V, T<sub>A</sub> = 25°C and not 100% tested.

**CAPACITANCE<sup>(1,2)</sup>**

Symbol	Parameter	Conditions	Max.	Unit
C <sub>IN</sub>	Input Capacitance	V <sub>IN</sub> = 0V	6	pF
C <sub>OUT</sub>	Input/Output Capacitance	V <sub>OUT</sub> = 0V	8	pF

**Notes:**

1. Tested initially and after any design or process changes that may affect these parameters.
2. Test conditions: T<sub>A</sub> = 25°C, f = 1 MHz, V<sub>DD</sub> = 3.3V.

**3.3V I/O AC TEST CONDITIONS**

Parameter	Unit
Input Pulse Level	0V to 3.0V
Input Rise and Fall Times	1.5 ns
Input and Output Timing and Reference Level	1.5V
Output Load	See Figures 1 and 2

**AC TEST LOADS**

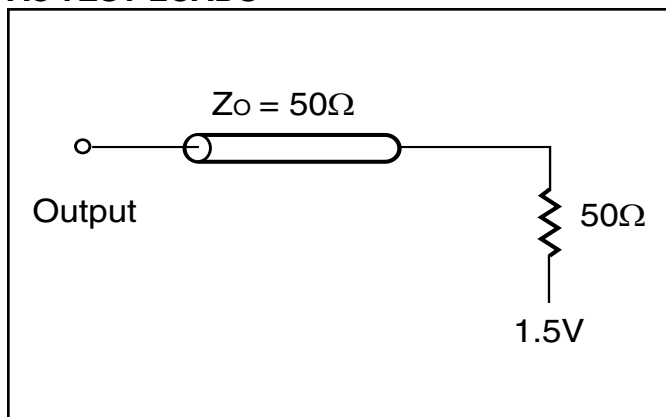

Figure 1

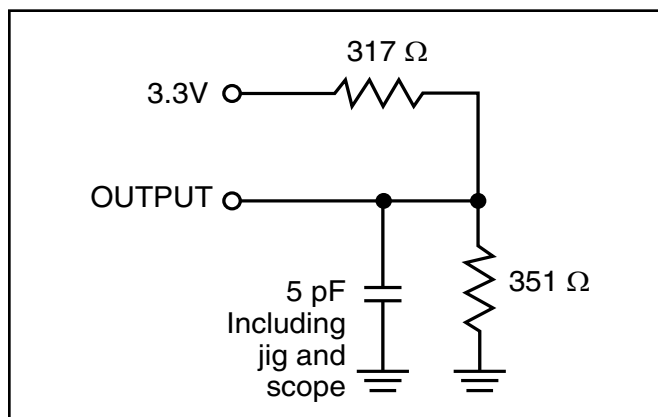

Figure 2

## 2.5V I/O AC TEST CONDITIONS

Parameter	Unit
Input Pulse Level	0V to 2.5V
Input Rise and Fall Times	1.5 ns
Input and Output Timing and Reference Level	1.25V
Output Load	See Figures 3 and 4

### 2.5 I/O OUTPUT LOAD EQUIVALENT

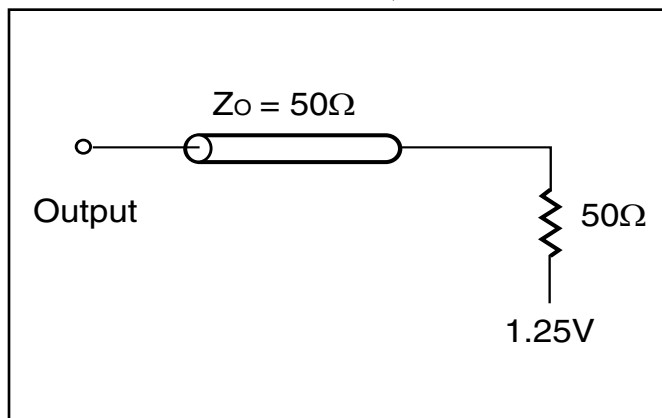

Figure 3

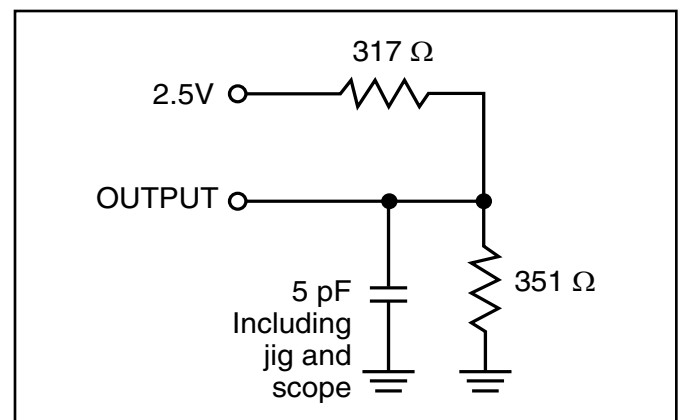

Figure 4

**READ/WRITE CYCLE SWITCHING CHARACTERISTICS** (Over Operating Range)

Symbol	Parameter	-200		-166		Unit
		Min.	Max.	Min.	Max.	
f <sub>MAX</sub>	Clock Frequency	—	200	—	166	MHz
t <sub>KC</sub>	Cycle Time	5	—	6	—	ns
t <sub>KH</sub>	Clock High Time	2	—	2.4	—	ns
t <sub>KL</sub>	Clock Low Time	2	—	2.4	—	ns
t <sub>KQ</sub>	Clock Access Time	—	3.1	—	3.5	ns
t <sub>KQX</sub> <sup>(2)</sup>	Clock High to Output Invalid	1.5	—	1.5	—	ns
t <sub>KQLZ</sub> <sup>(2,3)</sup>	Clock High to Output Low-Z	1	—	1	—	ns
t <sub>KQHZ</sub> <sup>(2,3)</sup>	Clock High to Output High-Z	—	3.0	—	3.4	ns
t <sub>OEQ</sub>	Output Enable to Output Valid	—	3.1	—	3.5	ns
t <sub>OEQX</sub> <sup>(2)</sup>	Output Disable to Output Invalid	0	—	0	—	ns
t <sub>OELZ</sub> <sup>(2,3)</sup>	Output Enable to Output Low-Z	0	—	0	—	ns
t <sub>OEHZ</sub> <sup>(2,3)</sup>	Output Disable to Output High-Z	—	3.0	—	3.4	ns
t <sub>AS</sub>	Address Setup Time	1.4	—	1.5	—	ns
t <sub>SS</sub>	Address Status Setup Time	1.4	—	1.5	—	ns
t <sub>WS</sub>	Read/Write Setup Time	1.4	—	1.5	—	ns
t <sub>CES</sub>	Chip Enable Setup Time	1.4	—	1.5	—	ns
t <sub>AVS</sub>	Address Advance Setup Time	1.4	—	1.5	—	ns
t <sub>DS</sub>	Data Setup Time	1.4	—	1.5	—	ns
t <sub>AH</sub>	Address Hold Time	0.4	—	0.5	—	ns
t <sub>SH</sub>	Address Status Hold Time	0.4	—	0.3	—	ns
t <sub>WH</sub>	Write Hold Time	0.4	—	0.5	—	ns
t <sub>CEH</sub>	Chip Enable Hold Time	0.4	—	0.5	—	ns
t <sub>AVH</sub>	Address Advance Hold Time	0.4	—	0.5	—	ns
t <sub>DH</sub>	Data Hold Time	0.4	—	0.5	—	ns
t <sub>PDS</sub>	ZZ High to Power Down	—	2	—	2	cyc
t <sub>PUS</sub>	ZZ Low to Power Down	—	2	—	2	cyc

**Note:**

1. Configuration signal MODE is static and must not change during normal operation.
2. Guaranteed but not 100% tested. This parameter is periodically sampled.
3. Tested with load in Figure 2.

**READ/WRITE CYCLE TIMING**

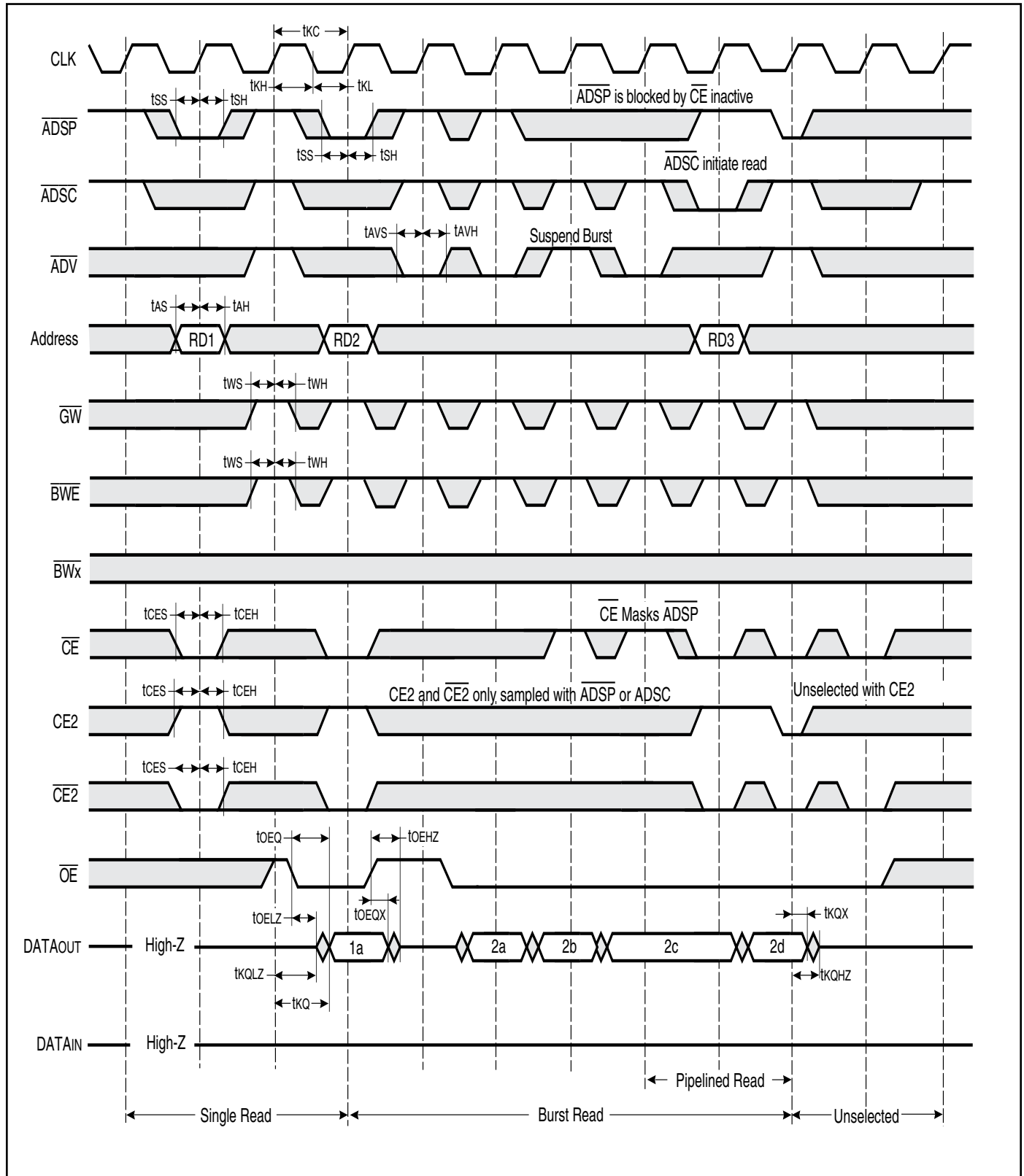

**WRITE CYCLE TIMING**

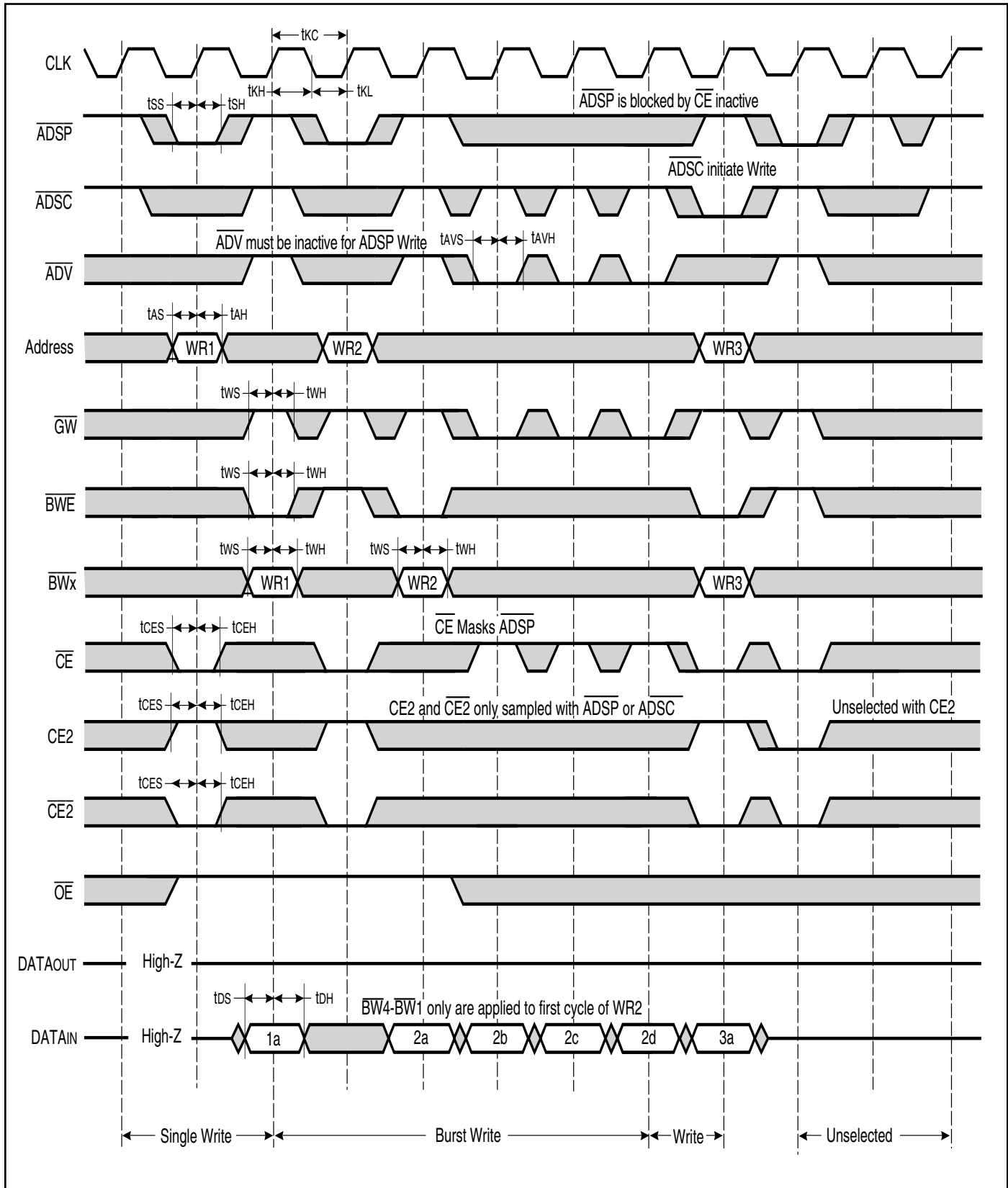

### SNOOZE MODE ELECTRICAL CHARACTERISTICS

Symbol	Parameter	Temperature	Conditions	Min.	Max.	Unit
ISB2	Current during SNOOZE MODE	Com. Ind.	$ZZ \geq V_{ih}$	— —	60 90	mA
$t_{PDS}$	ZZ active to input ignored			—	2	cycle
$t_{PUS}$	ZZ inactive to input sampled			2	—	cycle
$t_{ZZI}$	ZZ active to SNOOZE current			—	2	cycle
$t_{RZZI}$	ZZ inactive to exit SNOOZE current			0	—	ns

### SNOOZE MODE TIMING

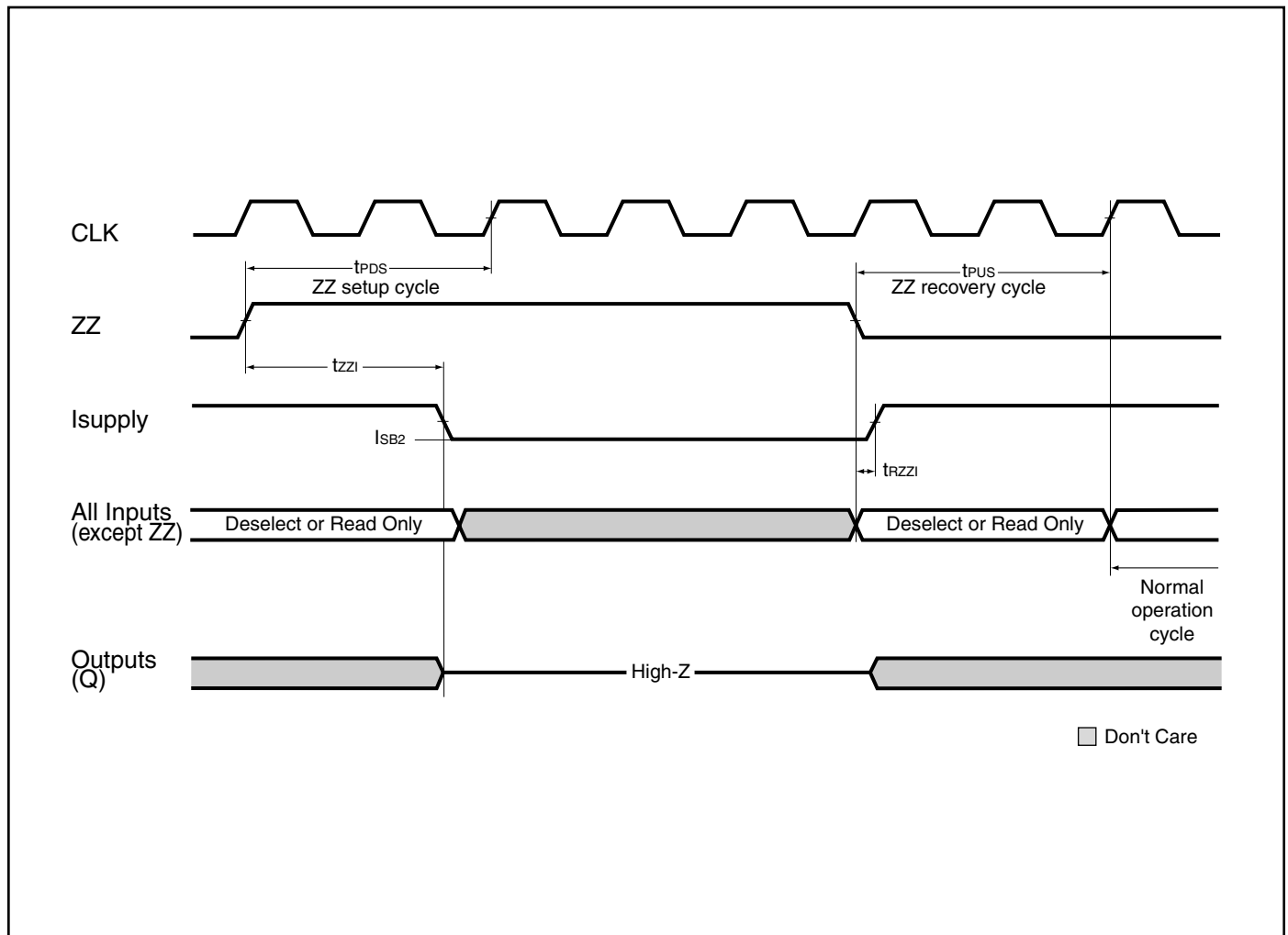

**ORDERING INFORMATION (3.3V core/2.5V-3.3V I/O)****Commercial Range: 0°C to +70°C**

Configuration	Frequency	Order Part Number	Package
<b>1Mx36</b>	166	IS61LPS102436A-166TQ	100 TQFP
		IS61LPS102436A-166TQL	100 TQFP, Lead-free
		IS61LPS102436A-166B3	165 PBGA
<b>2Mx18</b>	166	IS61LPS204818A-166TQ	100 TQFP
		IS61LPS204818A-166TQL	100 TQFP, Lead-free
		IS61LPS204818A-166B3	165 PBGA

**Industrial Range: -40°C to +85°C**

Configuration	Frequency	Order Part Number	Package
<b>1Mx36</b>	166	IS61LPS102436A-166TQI	100 TQFP
		IS61LPS102436A-166TQLI	100 TQFP, Lead-free
		IS61LPS102436A-166B3I	165 PBGA
		IS61LPS102436A-166B3LI	165 PBGA, Lead-free
<b>2Mx18</b>	166	IS61LPS204818A-166TQI	100 TQFP
		IS61LPS204818A-166B3I	165 PBGA



IS61VPS102436A, IS61LPS102436A, IS61VPS204818A, IS61LPS204818A

**ORDERING INFORMATION (2.5V core/2.5V I/O)**

**Commercial Range: 0°C to +70°C**

Configuration	Frequency	Order Part Number	Package
<b>1Mx36</b>	166	IS61VPS102436A-166TQ	100 TQFP
		IS61VPS102436A-166TQL	100 TQFP, Lead-free
		IS61VPS102436A-166B3	165 PBGA
<b>2Mx18</b>	166	IS61VPS204818A-166TQ	100 TQFP
		IS61VPS204818A-166TQL	100 TQFP, Lead-free
		IS61VPS204818A-166B3	165 PBGA

**Industrial Range: -40°C to +85°C**

Configuration	Frequency	Order Part Number	Package
<b>2Mx18</b>	166	IS61VPS204818A-166TQI	100 TQFP
		IS61VPS204818A-166B3I	165 PBGA

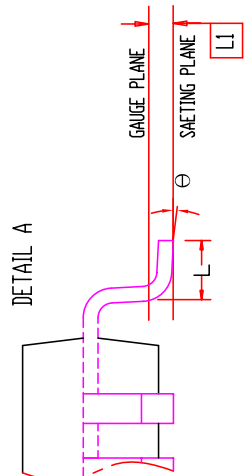
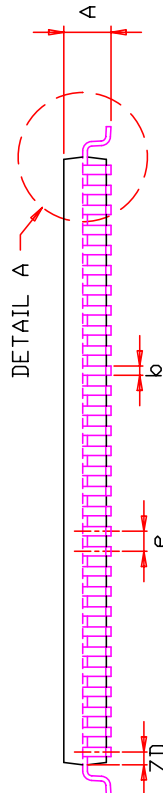
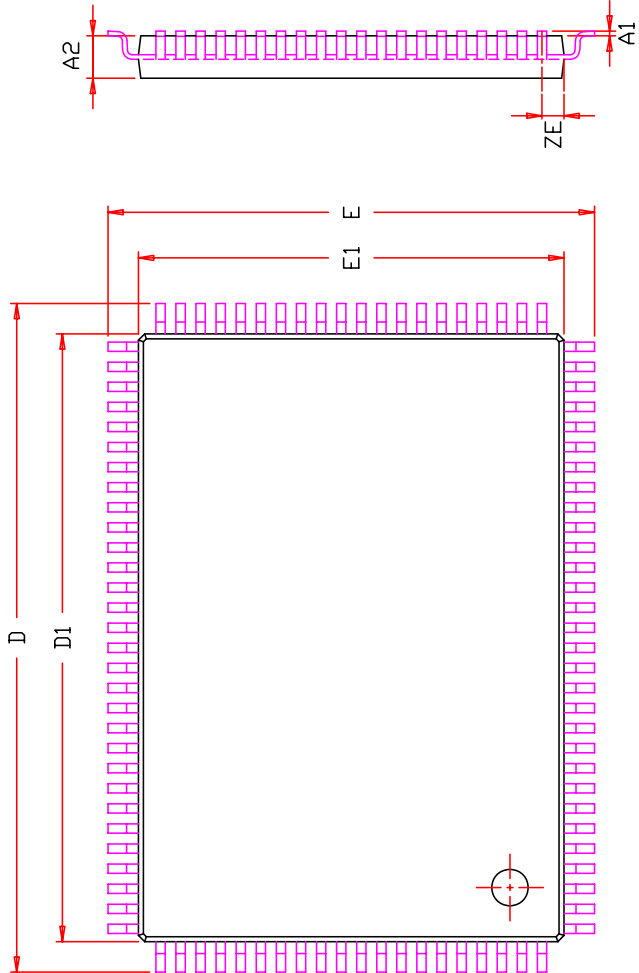

SYMBOL	DIMENSION IN MM		DIMENSION IN INCH	
	MIN.	NDM. MAX.	MIN.	NDM. MAX.
A	1.40	1.60	0.055	0.063
A1	0.05	0.15	0.002	0.006
A2	1.35	1.45	0.053	0.057
b	0.22	0.30	0.009	0.012
D	21.90	22.10	0.862	0.870
D1	19.90	20.10	0.783	0.791
E	15.90	16.10	0.626	0.634
E1	13.90	14.10	0.547	0.555
e	0.65 BSC.		0.026 BSC.	
L	0.45	0.60	0.018	0.024
L1	0.25 BSC.		0.010 BSC.	
ZD	0.575 REF.		0.023 REF.	
ZE	0.825 REF.		0.032 REF.	
θ	0	3.5°	0	3.5°

**NOTE :**

1. CONTROLLING DIMENSION : MM
2. DIMENSION D1 AND E1 DO NOT INCLUDE MOLD PROTRUSION.
3. DIMENSION b DOES NOT INCLUDE DAMBAR PROTRUSION/INTRUSION.



100L14x20x1.4mm LQFP  
(Footprint : 2.0 mm)  
Package Outline

TITLE

REV.

F

DATE

09/01/2009

280-600-011 REV. A

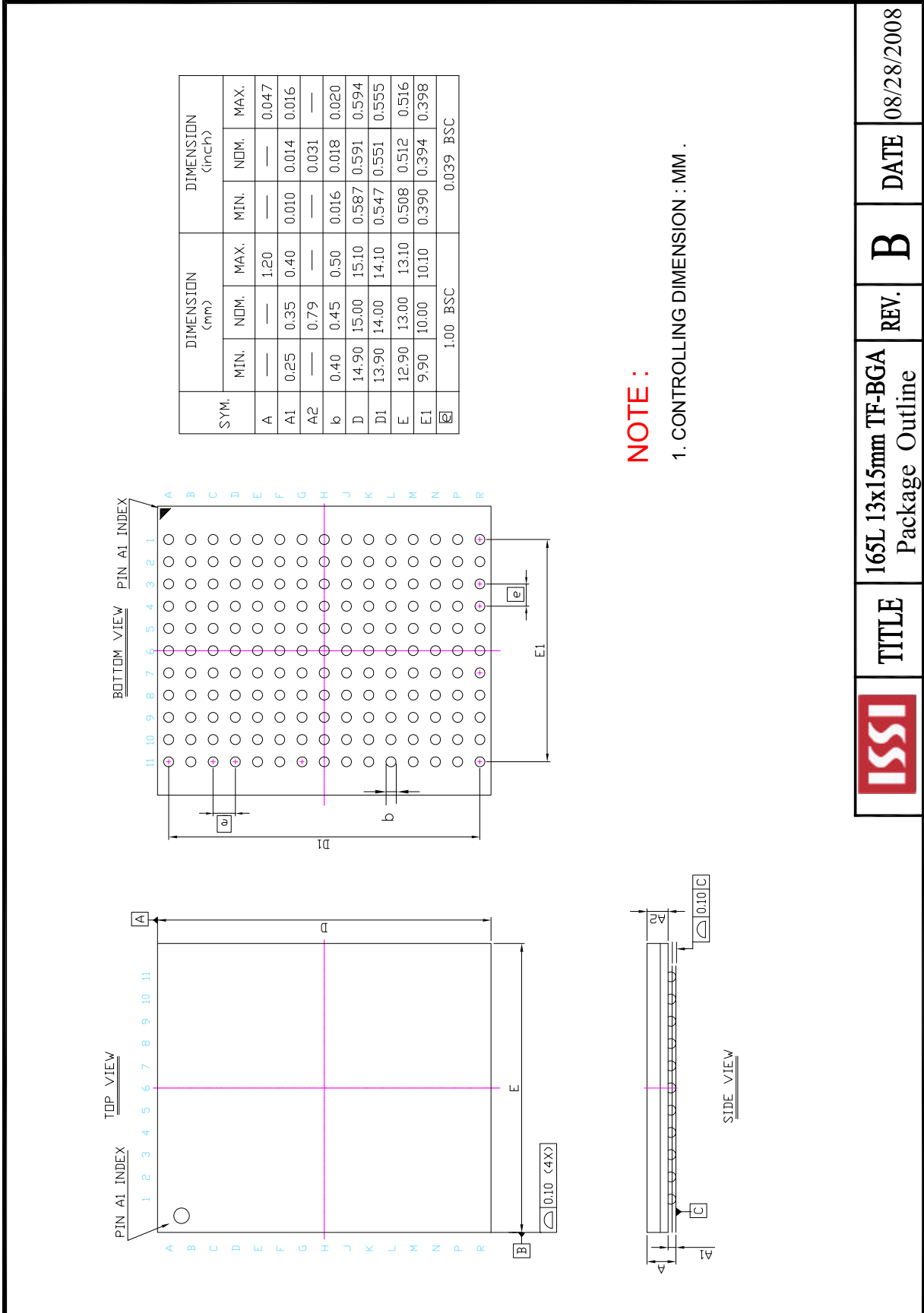

**TITLE**

**165L 13x15mm TF-BGA Package Outline**

**REV. B**

**DATE**

**08/28/2008**

## Looking for pricing, stock, or lifecycle information?

Click below to explore more details on WIN SOURCE:

- [⊖ View IS61VPS102436A-166TQL on WIN SOURCE](#)
- [⊖ ISSI, Integrated Silicon Solution Inc Information](#)

## Optimize Your Supply Chain with WIN SOURCE Solutions

- ✓ Global Sourcing Solution
- ✓ Obsolete Management
- ✓ Cost Control Management
- ✓ Shortage Management
- ✓ Alternative Solution
- ✓ Excess Inventory Management