

FULLY PROTECTED POWER MOSFET SWITCH

Features

- Controlled slew rate reduces EMI
- Over temperature protection with auto-restart
- Linear current-limit protection
- Active drain-to-source clamp
- ESD protection
- Lead compatible with standard Power MOSFET
- Low operating input current
- Monolithic construction

Description

The IRSF3021 Lamp and DC motor driver is a fully protected three terminal monolithic Smart Power MOSFET that features current limiting, over-temperature protection, ESD protection and over-voltage protection.

The on-chip protection circuit limits the drain current at 5.5A (typical) in the on-state, when the load is short circuited. The over-temperature circuitry turns off the Power MOSFET when the junction temperature exceeds 165°C (typical). The device restarts automatically once it has cooled down below the reset temperature.

The IRSF3021 is specifically designed for driving loads that require overload protection and in-rush current control while operating in automotive and industrial environments. Targeted applications include resistive loads such as lamps or capacitive loads such as airbag squibs and DC motor drives.

Product Summary

$V_{ds(clamp)}$	50V
$R_{ds(on)}$	200m Ω
I_{lim}	5.5A
$T_{j(sd)}$	165°C
EAS	200mJ

Applications

- Cabin Lighting
- Airbag System
- Programmable Logic Controller
- DC Motor Drive

Packages

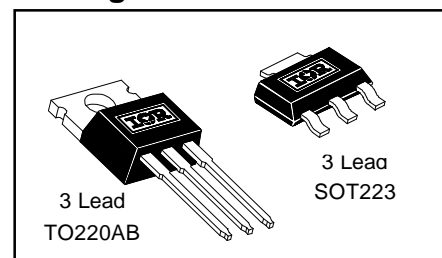

Block Diagram

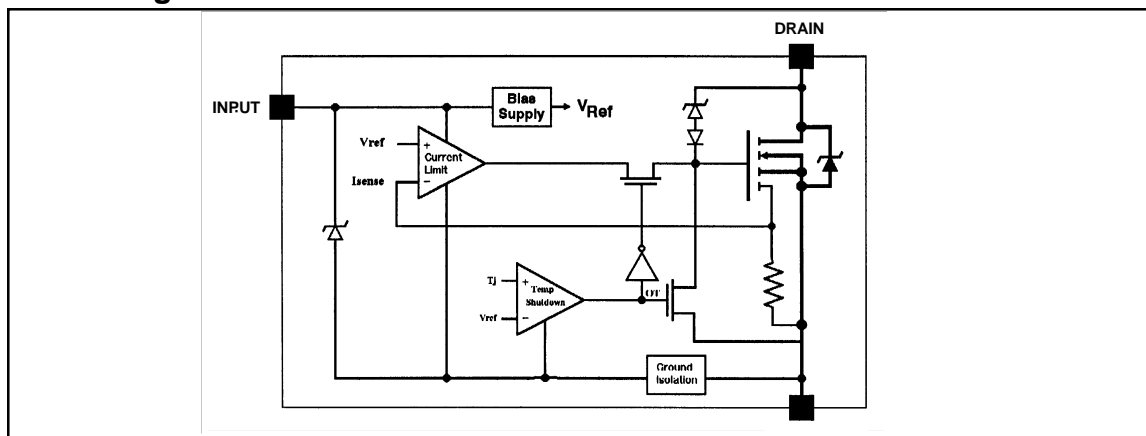

Absolute Maximum Ratings

Absolute Maximum Ratings indicate sustained limits beyond which damage to the device may occur. (T_C = 25°C unless otherwise specified.)

Symbol	Parameter	Min.	Max.	Units	Test Conditions
V _{ds, max}	Continuous drain to source voltage	—	50	V	
V _{in, max}	Continuous input voltage	-0.3	10		
I _{ds}	Continuous drain current	—	self limited	A	
P _d	Power dissipation	—	30	W	T _C ≤ 25°C, TO220
		—	3	W	T _C ≤ 25°C, SOT223
EAS	Unclamped single pulse inductive energy ^②	—	200	mJ	
V _{esd1}	Electrostatic discharge voltage (Human Body Model)	—	4000	V	100pF, 1.5kΩ
V _{esd2}	Electrostatic discharge voltage (Machine Model)	—	1000		200pF, 0Ω
T _{Jop}	Operating junction temperature range	-55	150	°C	
T _{Stg}	Storage temperature range	-55	150		
T _L	Lead temperature (soldering, 10 seconds)	—	300		

Static Electrical Characteristics

(T_C = 25°C unless otherwise specified.)

Symbol	Parameter	Min.	Typ.	Max.	Units	Test Conditions
V _{ds, clamp}	Drain to source clamp voltage	50	56	65	V	I _{ds} = 6A, t _p = 700 μS
R _{ds(on)}	Drain to source on resistance	—	155	200	mΩ	V _{in} = 5V, I _{ds} = 2A
I _{dss}	Drain to source leakage current	—	—	250	μA	V _{ds} = 40V, V _{in} = 0V
V _{th}	Input threshold voltage	1.0	2.0	3.0	V	V _{ds} = V _{in} , I _{ds} + I _{in} = 10mA
I _{i, on}	Input supply current (Normal Operation)	—	100	300	μA	V _{in} = 5V
I _{i, off}	Input supply current (Protection Mode)	—	250	500	μA	V _{in} = 5V
V _{in, clamp}	Input clamp voltage	9	10	—	V	I _{in} = 1mA
V _{sd}	Body-drain diode forward drop ^③	—	1.5	—		I _{ds} = -2A, R _{in} = 1kΩ

Thermal Characteristics

Symbol	Parameter	Min.	Typ.	Max.	Units	Test Conditions
R _{thjc}	Junction to case	—	—	4	°C/W	TO-220AB
R _{thja}	Junction to ambient	—	—	60		
R _{thjc}	Junction to case	—	—	40	°C/W	SOT-223
R _{thja}	Junction to PCB ^①	—	—	60		

NOTES:

- ① When mounted on a 1" square PCB (FR-4 or G10 material). For recommended footprint and soldering techniques, refer to International Rectifier Application Note AN-994.
- ② E_{AS} is tested with a constant current source of 6A applied for 700μS with V_{in} = 0V and starting T_j = 25°C.
- ③ Input current must be limited to less than 5mA with a 1kΩ resistor in series with the input when the Body-Drain Diode is forward biased.

Switching Electrical Characteristics

($V_{CC} = 14V$, resistive load (R_L) = 10Ω , $R_{in} = 100\Omega$. Specifications measured at $T_C = 25^\circ C$ unless otherwise specified.)

Symbol	Parameter	Min.	Typ.	Max.	Units	Test Conditions
t_{don}	Turn-on delay time	—	10	50	μs	$V_{in} = 0V$ to $5V$, 50% to 90%
t_r	Rise Time	—	30	80		$V_{in} = 0V$ to $5V$, 90% to 10%
t_{doff}	Turn-off delay time	—	20	60		$V_{in} = 5V$ to $0V$, 50% to 10%
t_f	Fall time	—	15	50	$V/\mu s$	$V_{in} = 5V$ to $0V$, 10% to 90%
SR	Output positive slew rate	-4	—	4		$V_{in} = 0V$ to $5V$, $+dV_{ds}/dt$
SR	Output negative slew rate	-4	—	4		$V_{in} = 5V$ to $0V$, $-dV_{ds}/dt$

Protection Characteristics

($T_C = 25^\circ C$ unless otherwise specified.)

Symbol	Parameter	Min.	Typ.	Max.	Units	Test Conditions
$I_{ds(lim)}$	Current limit	3.0	5.5	8.0	A	$V_{in} = 5V$, $V_{ds} = 14V$
$T_{j(sd)}$	Over temperature shutdown threshold	155	165	—	$^\circ C$	$V_{in} = 5V$, $I_{ds} = 2A$
$V_{protect}$	Min. input voltage for over-temp function	—	3	—	V	
t_{lres}	Current limit response time	—	TBD	—	μs	
I_{peak}	Peak short circuit current	—	10	—	A	
t_{Tresp}	Over-temperature response time	—	TBD	—	μs	

Lead Assignments

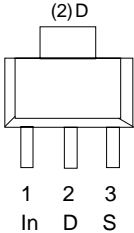
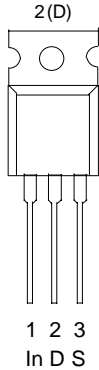
 <p>3 Lead - SOT223</p>	 <p>3 Lead - TO220</p>
IRSF3021L	IRSF3021
Part Number	

Case Outline - SOT-223

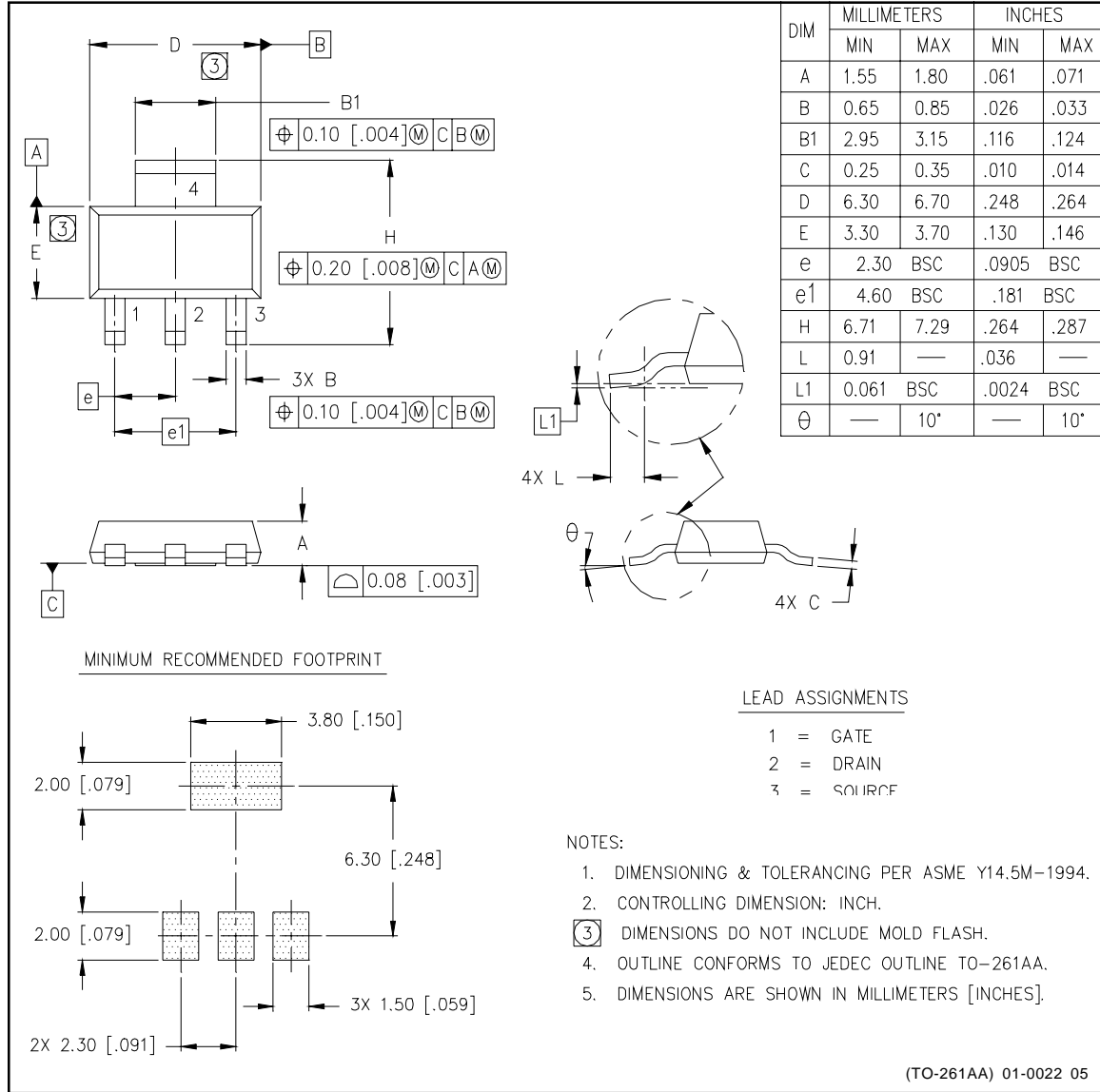

Case Outline 3 Lead - TO220

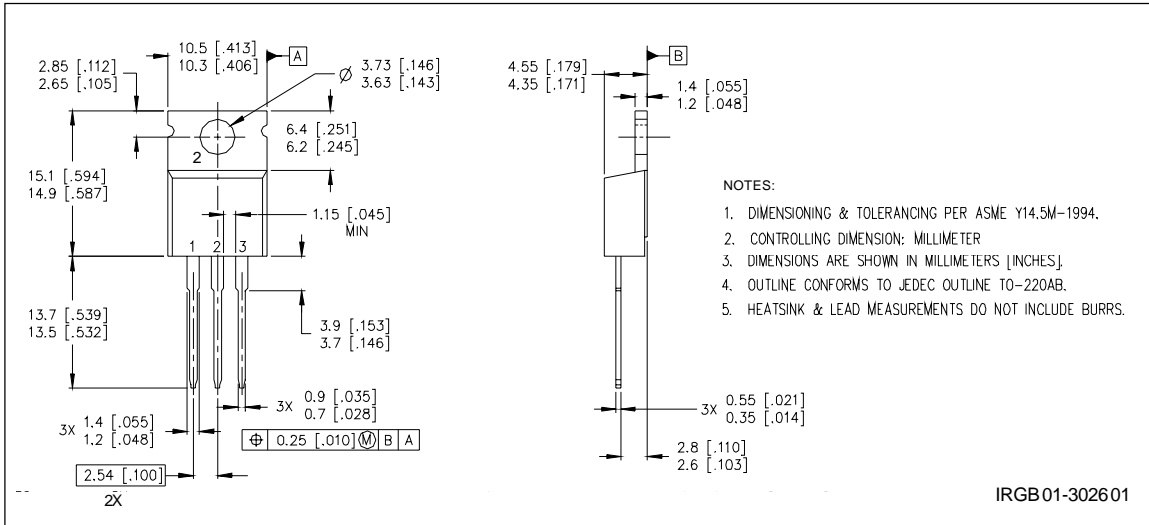

Tape & Reel - SOT223

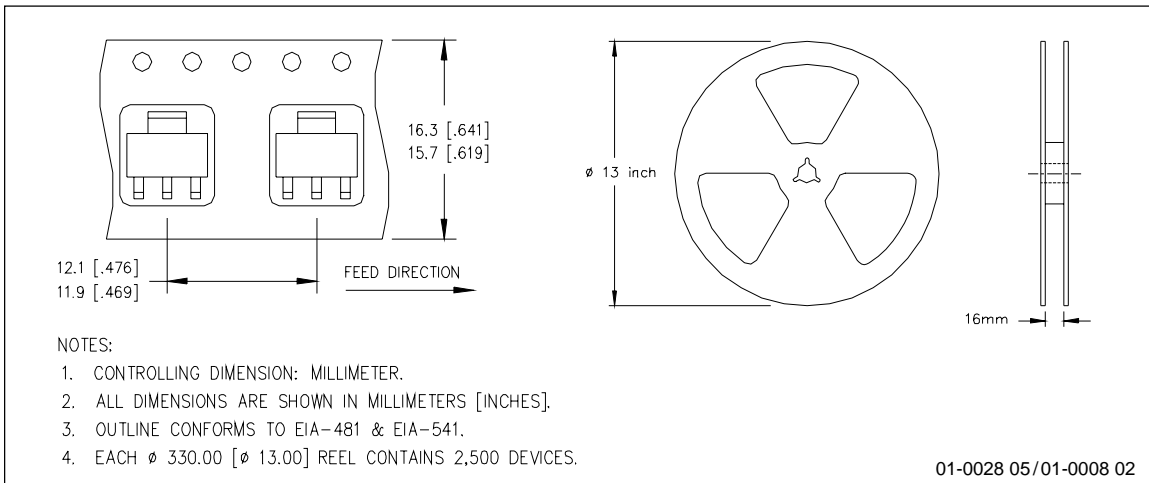

Note: For the most current drawings please refer to the IR website at:
<http://www.irf.com/package/>

Looking for pricing, stock, or lifecycle information?

Click below to explore more details on WIN SOURCE:

- ⊖ [View IRSF3021](#) on WIN SOURCE
- ⊖ [Infineon Technologies](#) Information

Optimize Your Supply Chain with WIN SOURCE Solutions

- ✓ Global Sourcing Solution
- ✓ Obsolete Management
- ✓ Cost Control Management
- ✓ Shortage Management
- ✓ Alternative Solution
- ✓ Excess Inventory Management