



**THE DATASHEET OF
IRMCK341TR**



Sensorless Motor Control IC for Appliances

Features

- **MCE™ (Motion Control Engine) - Hardware based computation engine for high efficiency sinusoidal sensorless control of permanent magnet AC motor**
- **Supports both interior and surface permanent magnet motors**
- **Built-in hardware peripheral for single shunt current feedback reconstruction**
- **No external current or voltage sensing operational amplifier required**
- **Three/two-phase Space Vector PWM**
- **Three-channel analog output (PWM)**
- **Embedded 8-bit high speed microcontroller (8051) for flexible I/O and man-machine control**
- **JTAG programming port for emulation/debugger**
- **Serial communication interface (UART)**
- **I²C/SPI serial interface**
- **Watchdog timer with independent analog clock**
- **Three general purpose timers/counters**
- **Two special timers: periodic timer, capture timer**
- **Internal 'One-Time Programmable' (OTP) memory and internal RAM for final production usage**
- **Pin compatible with IRMCF341, RAM version**
- **1.8V/3.3V CMOS**

Product Summary

Maximum crystal frequency	60 MHz
Maximum internal clock (SYSCLK) frequency	128 MHz
Maximum 8051 clock frequency	33 MHz
Sensorless control computation time	11 µsec typ
MCE™ computation data range	16 bit signed
8051 OTP Program memory	56K bytes
MCE program and Data RAM	8K bytes
GateKill latency (digital filtered)	2 µsec
PWM carrier frequency counter	16 bits/ SYSCLK
A/D input channels	8
A/D converter resolution	12 bits
A/D converter conversion speed	2 µsec
8051 instruction execution speed	2 SYSCLK
Analog output (PWM) resolution	8 bits
UART baud rate (typ)	57.6K bps
Number of I/O (max)	24
Package (lead-free)	QFP64
Operating temperature	-40°C ~ 85°C

Description

IRMCK341 is a high performance OTP based motion control IC designed primarily for appliance applications. IRMCK341 is designed to achieve low cost and high performance control solutions for advanced inverterized appliance motor control. IRMCK341 contains two computation engines. One is Motion Control Engine (MCE™) for sensorless control of permanent magnet motors; the other is an 8-bit high-speed microcontroller (8051). Both computation engines are integrated into one monolithic chip. The MCE™ contains a collection of control elements such as Proportional plus Integral, Vector rotator, Angle estimator, Multiply/Divide, Low loss SVPWM, Single Shunt IFB. The user can program a motion control algorithm by connecting these control elements using a graphic compiler. Key components of the sensorless control algorithms, such as the Angle Estimator, are provided as complete pre-defined control blocks implemented in hardware. A unique analog/digital circuit and algorithm to fully support single shunt current reconstruction is also provided. The 8051 microcontroller performs 2-cycle instruction execution (16MIPS at 33MHz). The MCE and 8051 microcontroller are connected via dual port RAM to process signal monitoring and command input. An advanced graphic compiler for the MCE™ is seamlessly integrated into the MATLAB/Simulink environment, while third party JTAG based emulator tools are supported for 8051 developments. IRMCK341 comes with a small QFP64 pin lead-free package.

TABLE OF CONTENTS

1	Overview	5
2	IRMCK341 Block Diagram and Main Functions	6
3	Pinout	8
4	Input/Output of IRMCK341	9
4.1	8051 Peripheral Interface Group	10
4.2	Motion Peripheral Interface Group	11
4.3	Analog Interface Group	11
4.4	Power Interface Group	12
4.5	Test Interface Group	12
5	Application Connections	13
6	DC Characteristics	14
6.1	Absolute Maximum Ratings	14
6.2	System Clock Frequency and Power Consumption	14
6.3	Digital I/O DC Characteristics	15
6.4	PLL and Oscillator DC characteristics	16
6.5	Analog I/O DC Characteristics	16
6.6	Under Voltage Lockout DC characteristics	17
6.7	AREF Characteristics	17
7	AC Characteristics	18
7.1	PLL AC Characteristics	18
7.2	Analog to Digital Converter AC Characteristics	19
7.3	Op amp AC Characteristics	19
7.4	SYNC to SVPWM and A/D Conversion AC Timing	20
7.5	GATEKILL to SVPWM AC Timing	21
7.6	Interrupt AC Timing	21
7.7	I ² C AC Timing	22
7.8	SPI AC Timing	23
7.8.1	SPI Write AC timing	23
7.8.2	SPI Read AC Timing	24
7.9	UART AC Timing	25
7.10	CAPTURE Input AC Timing	26
7.11	JTAG AC Timing	27
7.12	OTP Programming Timing	28
8	I/O Structure	29
9	Pin List	32
10	Package Dimensions	35
11	Part Marking Information	36
12	Order Information	36

TABLE OF FIGURES

Figure 1.	Typical Application Block Diagram Using IRMCK341.....	5
Figure 2.	IRMCK341 Internal Block Diagram.....	6
Figure 3.	IRMCK341 Pin Configuration.....	8
Figure 4.	Input/Output of IRMCK341	9
Figure 5.	Application Connection of IRMCK341	13
Figure 6.	Clock Frequency vs. Power Consumption.....	14
Figure 7	Crystal oscillator circuit.....	18
Figure 8	Voltage droop of sample and hold.....	19
Figure 9	SYNC to SVPWM and A/D Conversion AC Timing	20
Figure 10	GATEKILL to SVPWM AC Timing	21
Figure 11	Interrupt AC Timing	21
Figure 12	I ² C AC Timing	22
Figure 13	SPI Write AC Timing.....	23
Figure 14	SPI Read AC Timing.....	24
Figure 15	UART AC Timing	25
Figure 16	CAPTURE Input AC Timing.....	26
Figure 17	JTAG AC Timing.....	27
Figure 18	OTP Programming Timing.....	28
Figure 19	All digital I/O except motor PWM output.....	29
Figure 20	RESET, GATEKILL I/O	29
Figure 21	Analog input	30
Figure 22	Analog operational amplifier output and AREF I/O structure.....	30
Figure 23	VPP programming pin.....	30
Figure 24	VSS and AVSS pin structure.....	31
Figure 25	VDD1 and VDDCAP pin structure	31
Figure 26	XTAL0/XTAL1 pins structure	31

TABLE OF TABLES

Table 1.	Absolute Maximum Ratings	14
Table 2.	System Clock Frequency	14
Table 3.	Digital I/O DC Characteristics	15
Table 4.	PLL DC Characteristics	16
Table 5.	Analog I/O DC Characteristics	16
Table 6.	UVcc DC Characteristics	17
Table 7.	AREF DC Characteristics	17
Table 8.	PLL AC Characteristics.....	18
Table 9.	A/D Converter AC Characteristics	19
Table 10.	Current Sensing OP Amp AC Characteristics.....	19
Table 11.	SYNC AC Characteristics	20
Table 12.	GATEKILL to SVPWM AC Timing	21
Table 13.	Interrupt AC Timing.....	21
Table 14.	I ² C AC Timing	22
Table 15.	SPI Write AC Timing	23
Table 16.	SPI Read AC Timing.....	24
Table 17.	UART AC Timing	25
Table 18.	CAPTURE AC Timing	26
Table 19.	JTAG AC Timing	27
Table 20.	OTP Programming Timing	28
Table 21.	Pin List.....	34

1 Overview

IRMCK341 is a new International Rectifier integrated circuit device primarily designed as a one-chip solution for complete inverter controlled appliance motor control applications. Unlike a traditional microcontroller or DSP, the IRMCK341 provides a built-in closed loop sensorless control algorithm using the unique Motion Control Engine (MCE™) for permanent magnet motors. The MCE™ consists of a collection of control elements, motion peripherals, a dedicated motion control sequencer and dual port RAM to map internal signal nodes. IRMCK341 also employs a unique single shunt current reconstruction circuit to eliminate additional analog/digital circuitry and enables a direct shunt resistor interface to the IC. Motion control programming is achieved using a dedicated graphical compiler integrated into the MATLAB/Simulink™ development environment. Sequencing, user interface, host communication, and upper layer control tasks can be implemented in the 8051 high-speed 8-bit microcontroller. The 8051 microcontroller is equipped with a JTAG port to facilitate emulation and debugging tools. Figure 1 shows a typical application schematic using the IRMCK341.

IRMCK341 is intended for volume production purpose and contains 64K bytes of OTP (One Time Programming) ROM, which can be programmed through a JTAG port. For a development purpose use, IRMCF341 contains a 48k byte of RAM in place of program OTP to facilitate an application development work. Both IRMCF341 and IRMCK341 come in the same 64-pin QFP package with identical pin configuration to facilitate PC board layout and transition to mass production

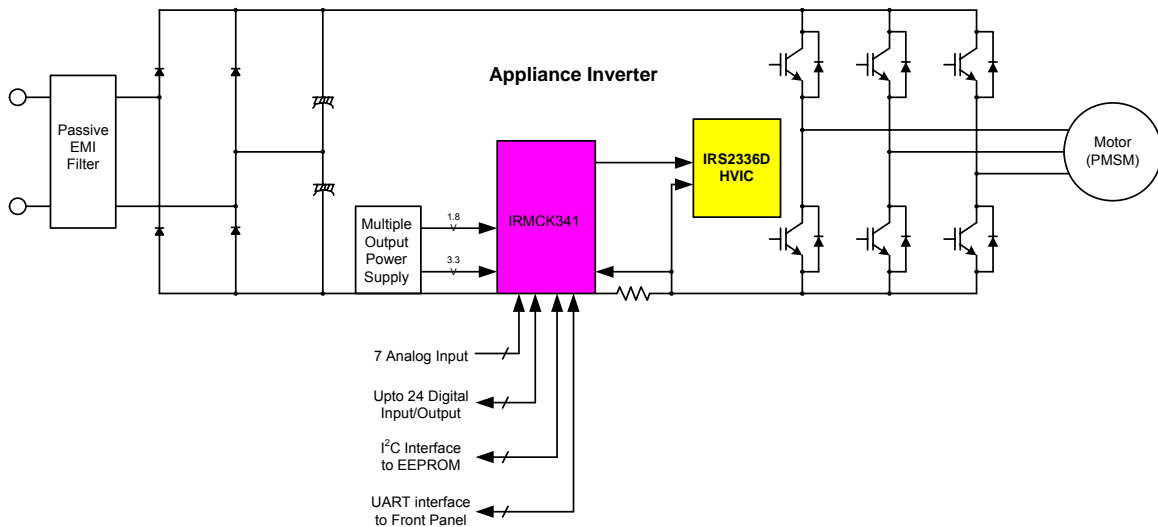

Figure 1. Typical Application Block Diagram Using IRMCK341

2 IRMCK341 Block Diagram and Main Functions

IRMCK341 block diagram is shown in Figure 2.

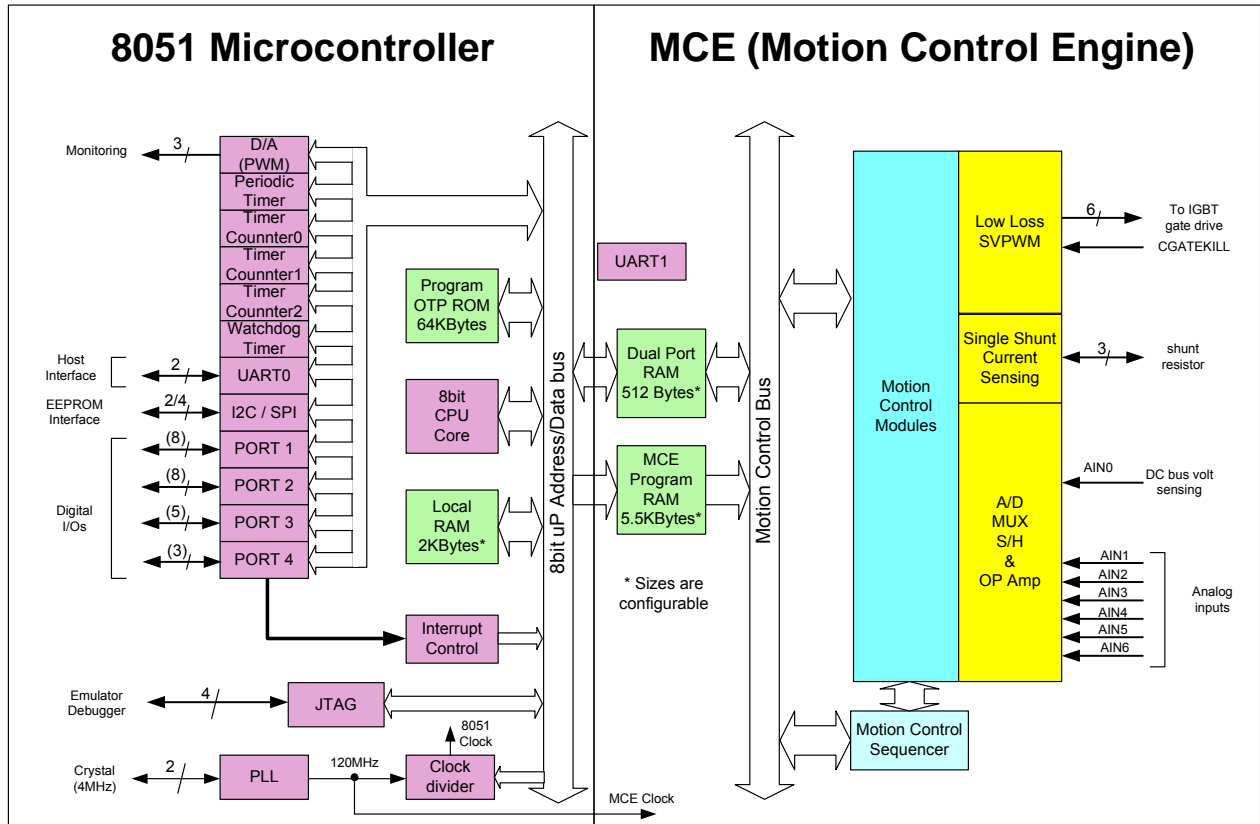

Figure 2. IRMCK341 Internal Block Diagram

IRMCK341 contains the following functions for sensorless AC motor control applications:

- Motion Control Engine (MCE™)
 - Proportional plus Integral block
 - Low pass filter
 - Differentiator and lag (high pass filter)
 - Ramp
 - Limit
 - Angle estimate (sensorless control)
 - Inverse Clark transformation
 - Vector rotator
 - Bit latch
 - Peak detect
 - Transition
 - Multiply-divide (signed and unsigned)

- Divide (signed and unsigned)
- Adder
- Subtractor
- Comparator
- Counter
- Accumulator
- Switch
- Shift
- ATAN (arc tangent)
- Function block (any curve fitting, nonlinear function)
- 16-bit wide Logic operations (AND, OR, XOR, NOT, NEGATE)
- MCE™ program and data memory (6K byte).^{Note 1}
- MCE™ control sequencer

- 8051 microcontroller
 - Three 16-bit timer/counters
 - 16-bit periodic timer
 - 16-bit analog watchdog timer
 - 16-bit capture timer
 - Up to 24 discrete I/Os
 - Eight-channel 12-bit A/D
 - One buffered channel for current sensing (0 – 1.2V input)
 - Seven unbuffered channels (0 – 1.2V input)
 - JTAG port (4 pins)
 - Up to three channels of analog output (8-bit PWM)
 - UART
 - I²C/SPI port
 - 64K byte program OTP
 - 2K byte data RAM.^{Note 1}

Note 1: Total size of RAM is 8K byte including MCE program, MCE data, and 8051 data. Different sizes can be allocated depending on applications.

3 Pinout

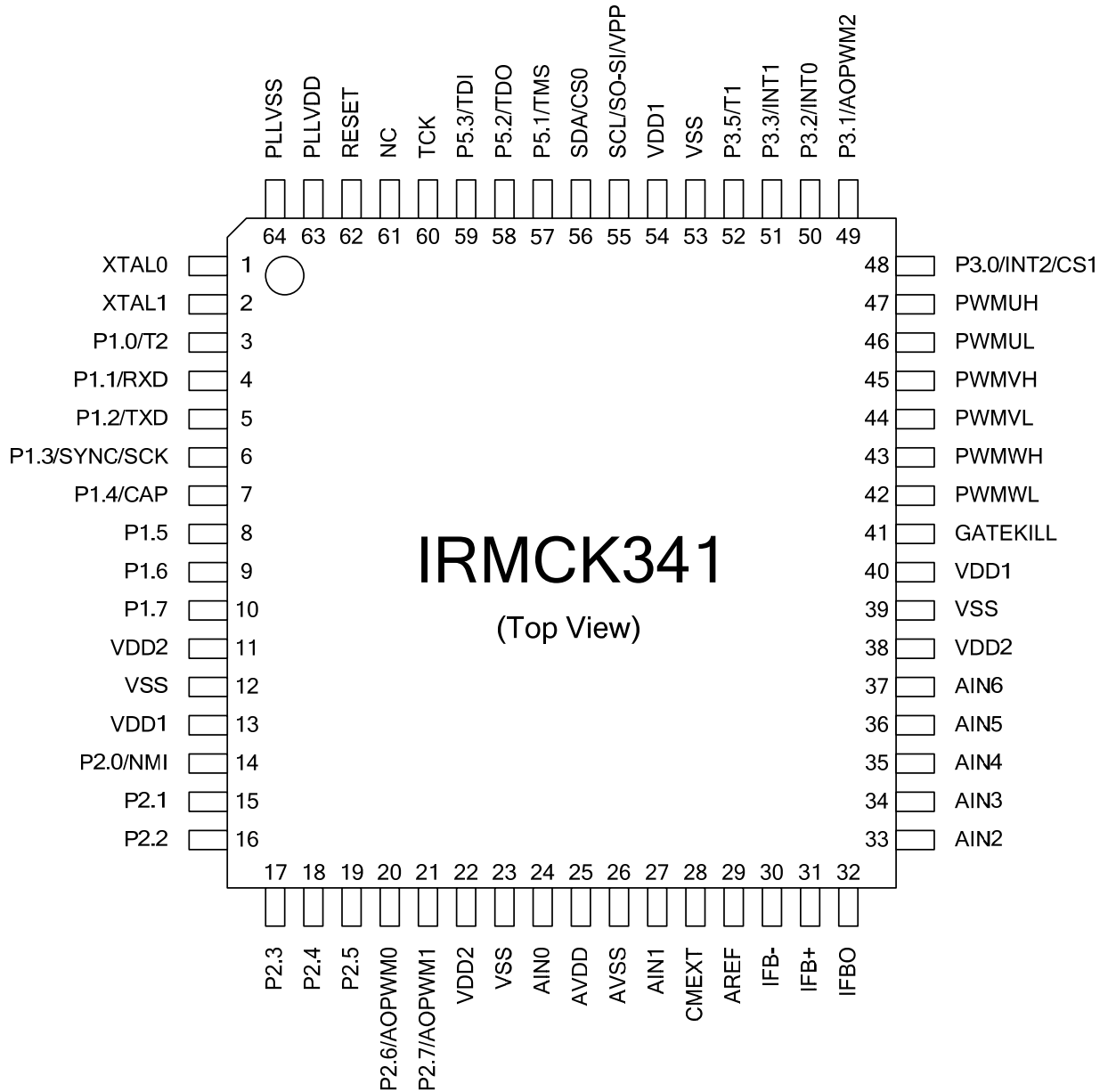

Figure 3. IRMCK341 Pin Configuration

4 Input/Output of IRMCK341

All I/O signals of IRMCK341 are shown in Figure 4. All I/O pins are 3.3V logic interface except A/D interface pins.

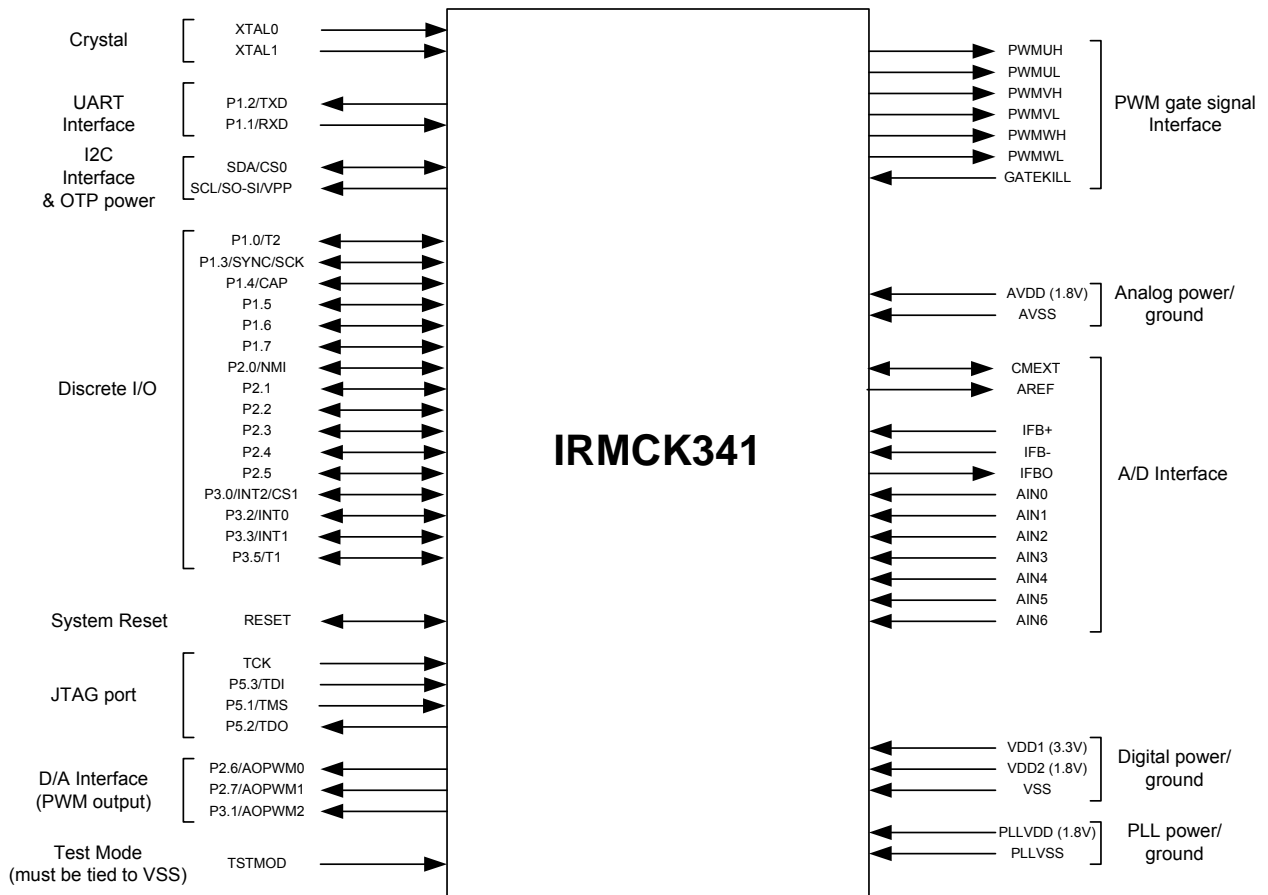

Figure 4. Input/Output of IRMCK341

4.1 8051 Peripheral Interface Group

UART Interface

TXD	Output, Transmit data from IRMCK341
RXD	Input, Receive data to IRMCK341

Discrete I/O Interface

P1.0/T2	Input/output port 1.0, can be configured as Timer/Counter 2 input
P1.1/RXD	Input/output port 1.1, can be configured as RXD input
P1.2/TXD	Input/output port 1.2, can be configured as TXD output
P1.3/SYNC/SCK	Input/output port 1.3, can be configured as SYNC output or SPI clock output
P1.4/CAP	Input/output port 1.4, can be configured as Capture Timer input
P1.5	Input/output port 1.5
P1.6	Input/output port 1.6
P1.7	Input/output port 1.7
P2.0/NMI	Input/output port 2.0, can be configured as non-maskable interrupt input
P2.1	Input/output port 2.1
P2.2	Input/output port 2.2
P2.3	Input/output port 2.3
P2.4	Input/output port 2.4
P2.5	Input/output port 2.5
P2.6/AOPWM0	Input/output port 2.6, can be configured as AOPWM0 output
P2.7/AOPWM1	Input/output port 2.7, can be configured as AOPWM1 output
P3.0/INT2/CS1	Input/output port 3.0, can be configured as INT2 input or SPI chip select 1
P3.1/AOPWM2	Input/output port 3.1, can be configured as AOPWM2 output
P3.2/NINT0	Input/output port 3.2, can be configured as INT0 input
P3.3/NINT1	Input/output port 3.3, can be configured as INT1 input
P3.5/T1	Input/output port 3.5, can be configured as Timer/Counter 1 input
P5.1/TSM	Input/output port 5.1, configured as JTAG port by default
P5.2/TDO	Input/output port 5.2, configured as JTAG port by default
P5.3/TDI	Input/output port 5.3, configured as JTAG port by default

Analog Output Interface

P2.6/AOPWM0	Input/output, can be configured as 8-bit PWM output 0 with programmable carrier frequency
P2.7/AOPWM1	Input/output, can be configured as 8-bit PWM output 1 with programmable carrier frequency
P3.1/AOPWM2	Input/output, can be configured as 8-bit PWM output 2 with programmable carrier frequency

Crystal Interface

XTAL0	Input, connected to crystal
XTAL1	Output, connected to crystal

Reset Interface

RESET	Inout, system reset, needs to be pulled up to VDD1 but doesn't require external RC time constant
-------	--

I²C Interface

SCL/SO-SI Output, I²C clock output, or SPI data
 SDA/CS0 Input/output, I²C Data line or SPI chip select 0

I²C/SPI Interface and OTP power

SCL/SO-SI/VPP Output, I²C clock output, or SPI data or OTP programming power
 SDA/CS0 Input/output, I²C data line or SPI chip select 0
 P1.3/SYNC/SCK Input/output port 1.3, can be configured as SYNC output or SPI clock output
 P3.0/INT2/CS1 Input/output port 3.0, can be configured as INT2 input or SPI chip select 1

4.2 Motion Peripheral Interface Group

PWM

PWMUH Output, PWM phase U high side gate signal
 PWMUL Output, PWM phase U low side gate signal
 PWMVH Output, PWM phase V high side gate signal
 PWMVL Output, PWM phase V low side gate signal
 PWMWH Output, PWM phase W high side gate signal
 PWMWL Output, PWM phase W low side gate signal

Fault

GATEKILL Input, upon assertion, this negates all six PWM signals, programmable logic sense

4.3 Analog Interface Group

AVDD Analog power (1.8V)
 AVSS Analog power return
 AREF 0.6V buffered output
 CMEXT Unbuffered 0.6V, input to the AREF buffer, capacitor needs to be connected.
 IFB+ Input, Operational amplifier positive input for shunt resistor current sensing
 IFB- Input, Operational amplifier negative input for shunt resistor current sensing
 IFBO Output, Operational amplifier output for shunt resistor current sensing
 AIN0 Input, Analog input channel 0 (0 – 1.2V), typically configured for DC bus voltage input
 AIN1 Input, Analog input channel 1 (0 – 1.2V), needs to be pulled down to AVSS if unused
 AIN2 Input, Analog input channel 2 (0 – 1.2V), needs to be pulled down to AVSS if unused
 AIN3 Input, Analog input channel 3 (0 – 1.2V), needs to be pulled down to AVSS if unused
 AIN4 Input, Analog input channel 4 (0 – 1.2V), needs to be pulled down to AVSS if unused

AIN5	Input, Analog input channel 5 (0 – 1.2V), needs to be pulled down to AVSS if unused
AIN6	Input, Analog input channel 6 (0 – 1.2V), needs to be pulled down to AVSS if unused

4.4 Power Interface Group

VDD1	Digital power for I/O (3.3V)
VDD2	Digital power for core logic (1.8V)
VSS	Digital common
PLLVDD	PLL power (1.8V)
PLLVSS	PLL ground return

4.5 Test Interface Group

TSTMOD	Must be tied to VSS, used only for factory testing.
P5.1/TSM	Input/output port 5.1, configured as JTAG port by default
P5.2/TDO	Input/output port 5.2, configured as JTAG port by default
P5.3/TDI	Input/output port 5.3, configured as JTAG port by default
TCK	Input, JTAG test clock

5 Application Connections

Typical application connection is shown in Figure 5. All components necessary to implement a complete sensorless drive control algorithm are shown connected to IRMCK341.

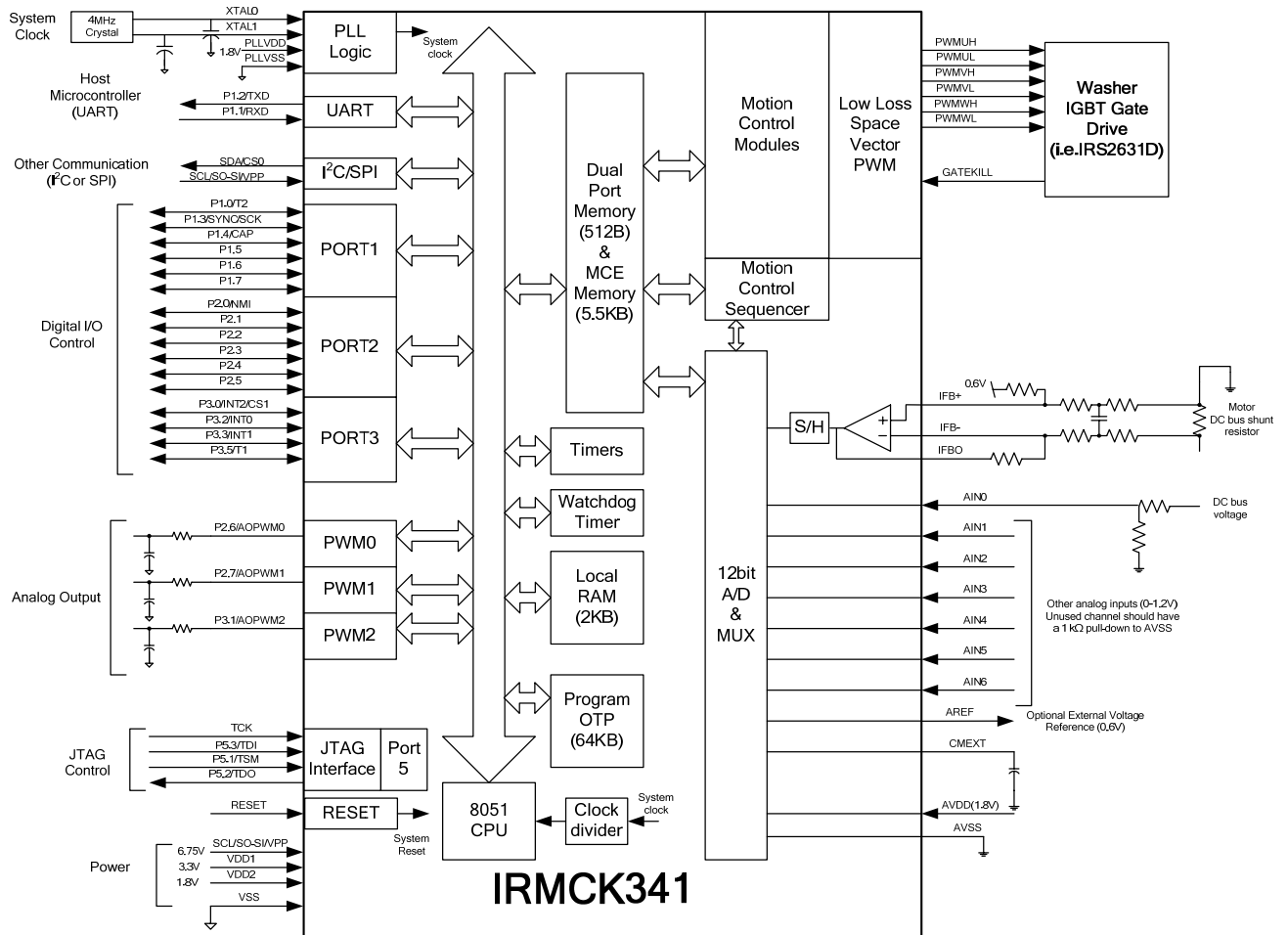

Figure 5. Application Connection of IRMCK341

6 DC Characteristics

6.1 Absolute Maximum Ratings

Symbol	Parameter	Min	Typ	Max	Condition
V _{DD1}	Supply Voltage	-0.3 V	-	3.6 V	Respect to VSS
V _{DD2}	Supply Voltage	-0.3 V	-	1.98 V	Respect to VSS
V _{PP}	OTP Programming Voltage	-0.3V	-	7.0V	Respect to VSS
V _{IA}	Analog Input Voltage	-0.3 V	-	1.98 V	Respect to AVSS
V _{ID}	Digital Input Voltage	-0.3 V	-	3.65 V	Respect to VSS
T _A	Ambient Temperature	-40 °C	-	85 °C	
T _S	Storage Temperature	-65 °C	-	150 °C	

Table 1. Absolute Maximum Ratings

Caution: Stresses beyond those listed in “Absolute Maximum Ratings” may cause permanent damage to the device. These are stress ratings only and function of the device at these or any other conditions beyond those indicated in the operational sections of the specifications are not implied.

6.2 System Clock Frequency and Power Consumption

Symbol	Parameter	Min	Typ	Max	Unit
SYSCLK	System Clock	32	-	128	MHz
8051CLK	8051 Clock	-	-	32	MHz

Table 2. System Clock Frequency

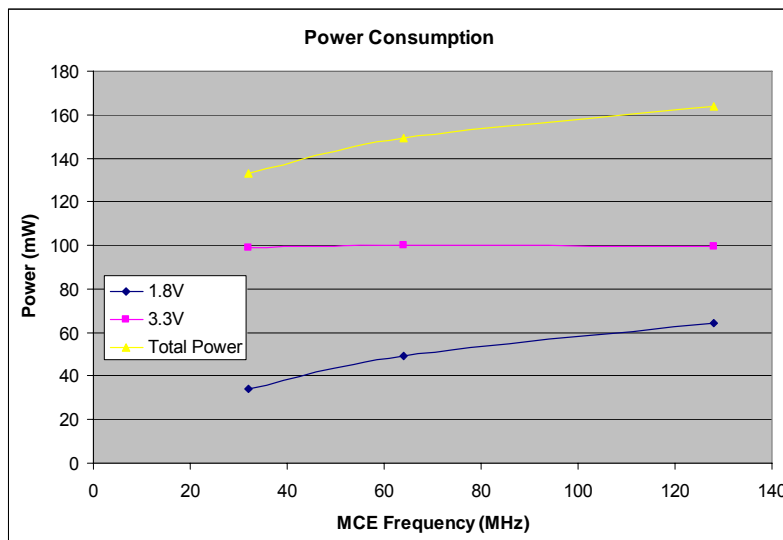

6.3 Digital I/O DC Characteristics

Symbol	Parameter	Min	Typ	Max	Condition
V _{DD1}	Supply Voltage	3.0 V	3.3 V	3.6 V	Recommended
V _{DD2}	Supply Voltage	1.62 V	1.8 V	1.98 V	Recommended
V _{PP}	OTP Programming voltage	6.5V	6.75V	7.0V	Recommended
V _{IL}	Input Low Voltage	-0.3 V	-	0.8 V	Recommended
V _{IH}	Input High Voltage	2.0 V		3.6 V	Recommended
C _{IN}	Input capacitance	-	3.6 pF	-	(1)
I _L	Input leakage current		±10 nA	±1 µA	V _O = 3.3 V or 0 V
I _{OL1} ⁽²⁾	Low level output current	8.9 mA	13.2 mA	15.2 mA	V _{OL} = 0.4 V (1)
I _{OH1} ⁽²⁾	High level output current	12.4 mA	24.8 mA	38 mA	V _{OH} = 2.4 V (1)
I _{OL2} ⁽³⁾	Low level output current	17.9 mA	26.3 mA	33.4 mA	V _{OL} = 0.4 V (1)
I _{OH2} ⁽³⁾	High level output current	24.6 mA	49.5 mA	81 mA	V _{OH} = 2.4 V (1)

Table 3. Digital I/O DC Characteristics

Note:

- (1) Data guaranteed by design.
- (2) Applied to SCL/SO-SI, SDA/CS0 pins.
- (3) Applied to P1.0/T2, P1.1/RXD, P1.2/TXD, P1.3/SYNC/SCK, P1.4/CAP, P1.5, P1.6, P1.7, P2.0/NMI, P2.1, P2.2, P2.3, P2.4, P2.5, P2.6/AOPWM0, P2.7/AOPWM1, P3.0/INT2/CS1, P3.1/AOPWM2, P3.2/INT0, P3.3/INT1, P3.5/T1, P3.6/RXD1, P3.7/TXD1, P5.1/TMS, P5.2/TDO, P5.3/TDI, GATEKILL, PWMUL, PWMUH, PWMVL, PWMVH, PWMWL, and PWMWH pins.

6.4 PLL and Oscillator DC characteristics

Symbol	Parameter	Min	Typ	Max	Condition
V _{PLLVD}	Supply Voltage	1.62 V	1.8 V	1.92 V	Recommended
V _{IL OSC}	Oscillator Input Low Voltage	V _{PLLSS}	-	0.2* V _{PLLVD}	V _{PLLVD} = 1.8 V (1)
V _{IH OSC}	Oscillator Input High Voltage	0.8* V _{PLLVD}		V _{PLLVD}	V _{PLLVD} = 1.8 V (1)

Table 4. PLL DC Characteristics

Note:

(1) Data guaranteed by design.

6.5 Analog I/O DC Characteristics

- OP amp for current sensing (IFB+, IFB-, IFBO)

C_{AREF} = 1nF, C_{MEXT} = 100nF. Unless specified, Ta = 25°C.

Symbol	Parameter	Min	Typ	Max	Condition
V _{AVDD}	Supply Voltage	1.71 V	1.8 V	1.89 V	Recommended
V _{OFFSET}	Input Offset Voltage	-	-	26 mV	V _{AVDD} = 1.8 V
V _I	Input Voltage Range	0 V		1.2 V	Recommended
V _{OUTSW}	OP amp output operating range	50 mV (1)	-	1.2 V	V _{AVDD} = 1.8 V
C _{IN}	Input capacitance	-	3.6 pF	-	(1)
R _{FDBK}	OP amp feedback resistor	5 kΩ	-	20 kΩ	Requested between IFBO and IFB-
OP _{GAINCL}	Operating Close loop Gain	80 db	-	-	(1)
CMRR	Common Mode Rejection Ratio	-	80 db	-	(1)
I _{SRC}	Op amp output source current	-	1 mA	-	V _{OUT} = 0.6 V (1)
I _{SNK}	Op amp output sink current	-	100 μA	-	V _{OUT} = 0.6 V (1)

Table 5. Analog I/O DC Characteristics

Note: (1) Data guaranteed by design.

6.6 Under Voltage Lockout DC characteristics

Unless specified, $T_a = 25^\circ\text{C}$, AVDD (1.8V)

Symbol	Parameter	Min	Typ	Max	Condition
UV _{CC+}	UVcc positive going Threshold ⁽¹⁾	1.53 V	1.66 V	1.71 V	V _{DD1} = 3.3 V
UV _{CC-}	UVcc negative going Threshold	1.52 V	1.62 V	1.71 V	V _{DD1} = 3.3 V
UV _{CCH}	UVcc Hysteresys	-	40 mV	-	

Table 6. UVcc DC Characteristics

Note: (1) Data guaranteed by design.

6.7 AREF Characteristics

C_{AREF} = 1nF, C_{MEXT} = 100nF. Unless specified, $T_a = 25^\circ\text{C}$.

Symbol	Parameter	Min	Typ	Max	Condition
V _{AREF}	AREF Output Voltage	495 mV	600 mV	700 mV	V _{AVDD} = 1.8 V
ΔV_o	Load regulation (V _{DC} -0.6)	-	1 mV	-	(1)
PSRR	Power Supply Rejection Ratio	-	75 db	-	(1)

Table 7. AREF DC Characteristics

Note:

(1) Data guaranteed by design.

7 AC Characteristics

7.1 PLL AC Characteristics

Symbol	Parameter	Min	Typ	Max	Condition
F_{CLKIN}	Crystal input frequency	3.2 MHz	4 MHz	60 MHz	⁽¹⁾ (see figure below)
F_{PLL}	Internal clock frequency	32 MHz	50 MHz	128 MHz	⁽¹⁾
F_{LWPM}	Sleep mode output frequency	$F_{CLKIN} \div 256$	-	-	⁽¹⁾
J_S	Short time jitter	-	200 psec	-	⁽¹⁾
D	Duty cycle	-	50 %	-	⁽¹⁾
T_{LOCK}	PLL lock time	-	-	500 μ sec	⁽¹⁾

Table 8. PLL AC Characteristics

Note:

(1) Data guaranteed by design.

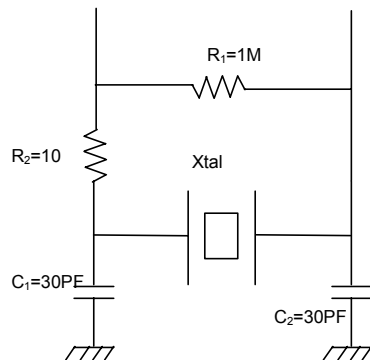

Figure 7 Crystal oscillator circuit

7.2 Analog to Digital Converter AC Characteristics

Unless specified, $T_a = 25^\circ\text{C}$.

Symbol	Parameter	Min	Typ	Max	Condition
T_{CONV}	Conversion time	-	-	2.05 μsec	⁽¹⁾
T_{HOLD}	Sample/Hold maximum hold time	-	-	10 μsec	Voltage droop \leq 15 LSB (see figure below)

Table 9. A/D Converter AC Characteristics

Note:

(1) Data guaranteed by design.

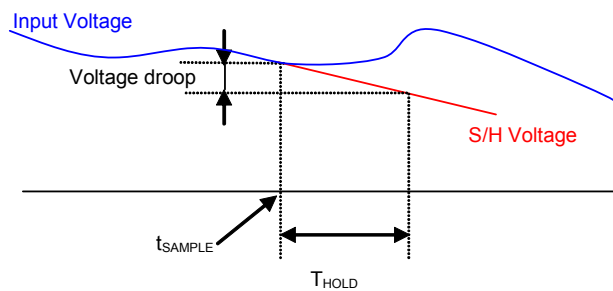

Figure 8 Voltage droop of sample and hold

7.3 Op amp AC Characteristics

- OP amp for current sensing (IFB+, IFB-, IFBO)

Unless specified, $T_a = 25^\circ\text{C}$.

Symbol	Parameter	Min	Typ	Max	Condition
OP_{SR}	OP amp slew rate	-	10 V/ μsec	-	$V_{\text{AVDD}} = 1.8 \text{ V}$, $CL = 33 \text{ pF}$ ⁽¹⁾
OP_{IMP}	OP input impedance	-	$10^8 \Omega$	-	⁽¹⁾
T_{SET}	Settling time	-	400 ns	-	$V_{\text{AVDD}} = 1.8 \text{ V}$, $CL = 33 \text{ pF}$ ⁽¹⁾

Table 10. Current Sensing OP Amp AC Characteristics

Note:

(1) Data guaranteed by design.

7.4 SYNC to SVPWM and A/D Conversion AC Timing

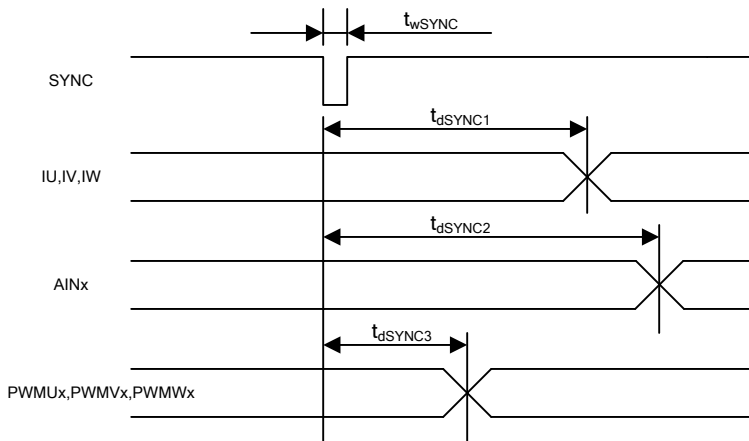

Figure 9 SYNC to SVPWM and A/D Conversion AC Timing

Unless specified, $T_a = 25^\circ\text{C}$.

Symbol	Parameter	Min	Typ	Max	Unit
t_{w_SYNC}	SYNC pulse width	-	32	-	SYSClk
t_{d_SYNC1}	SYNC to current feedback conversion time	-	-	100	SYSClk
t_{d_SYNC2}	SYNC to AIN0-6 analog input conversion time	-	-	200	SYSClk ⁽¹⁾
t_{d_SYNC3}	SYNC to PWM output delay time	-	-	2	SYSClk

Table 11. SYNC AC Characteristics

Note:

(1) AIN1 through AIN6 channels are converted once every 6 SYNC events

7.5 GATEKILL to SVPWM AC Timing

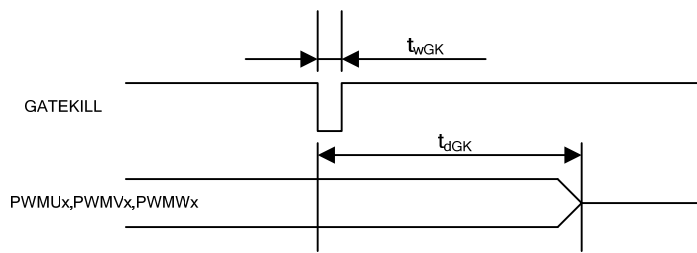

Figure 10 GATEKILL to SVPWM AC Timing

Unless specified, Ta = 25°C.

Symbol	Parameter	Min	Typ	Max	Unit
t _{wGK}	GATEKILL pulse width	32	-	-	SYSClk
t _{dGK}	GATEKILL to PWM output delay	-	-	100	SYSClk

Table 12. GATEKILL to SVPWM AC Timing

7.6 Interrupt AC Timing

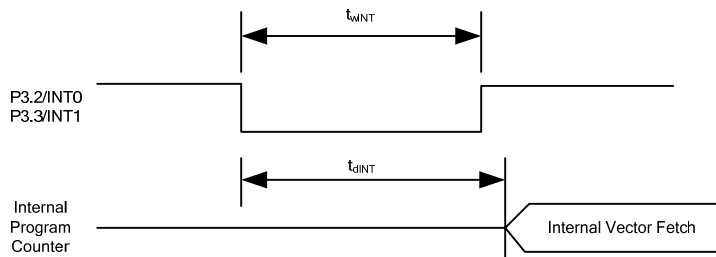

Figure 11 Interrupt AC Timing

Unless specified, Ta = 25°C.

Symbol	Parameter	Min	Typ	Max	Unit
t _{wINT}	INT0, INT1 Interrupt Assertion Time	4	-	-	SYSClk
t _{dINT}	INT0, INT1 latency	-	-	4	SYSClk

Table 13. Interrupt AC Timing

7.7 I²C AC Timing

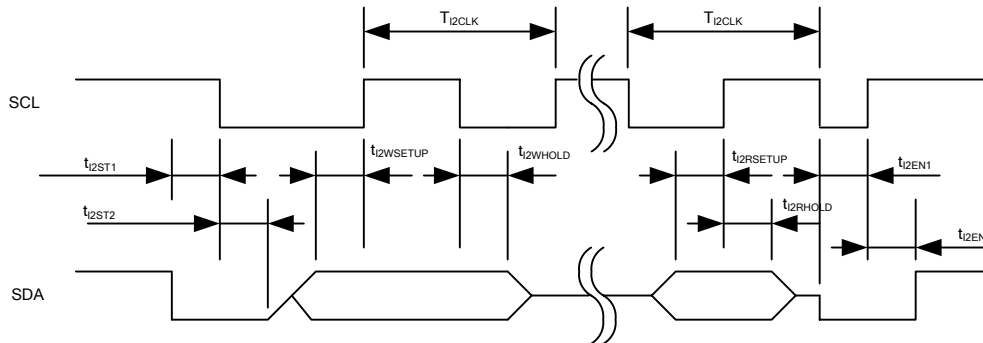

Figure 12 I²C AC Timing

Unless specified, Ta = 25°C.

Symbol	Parameter	Min	Typ	Max	Unit
T _{I2CLK}	I ² C clock period	10	-	8192	SYCLK
t _{I2ST1}	I ² C SDA start time	0.25	-	-	T _{I2CLK}
t _{I2ST2}	I ² C SCL start time	0.25	-	-	T _{I2CLK}
t _{I2WSETUP}	I ² C write setup time	0.25	-	-	T _{I2CLK}
t _{I2WHOLD}	I ² C write hold time	0.25	-	-	T _{I2CLK}
t _{I2RSETUP}	I ² C read setup time	I ² C filter time ⁽¹⁾	-	-	SYCLK
t _{I2RHOLD}	I ² C read hold time	1	-	-	SYCLK

Table 14. I²C AC Timing

Note:

- (1) I²C read setup time is determined by the programmable filter time applied to I²C communication.

7.8 SPI AC Timing

7.8.1 SPI Write AC timing

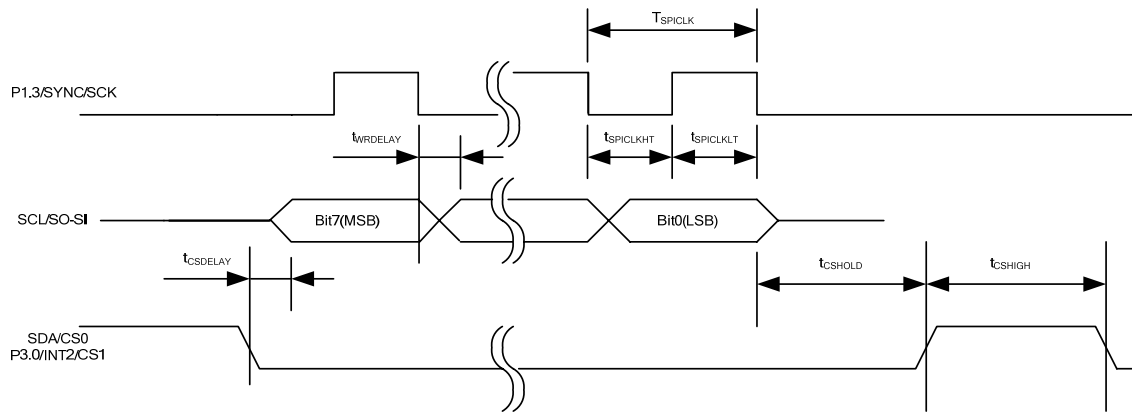

Figure 13 SPI Write AC Timing

Unless specified, $T_a = 25^\circ\text{C}$.

Symbol	Parameter	Min	Typ	Max	Unit
T_{SPICLK}	SPI clock period	4	-	-	SYSCLK
t_{SPICLKHT}	SPI clock high time	-	1/2	-	T_{SPICLK}
t_{SPICLKLT}	SPI clock low time	-	1/2	-	T_{SPICLK}
t_{CSDELAY}	CS to data delay time	-	-	10	nsec
t_{WRDELAY}	CLK falling edge to data delay time	-	-	10	nsec
t_{CSHIGH}	CS high time between two consecutive byte transfer	1	-	-	T_{SPICLK}
t_{CSHOLD}	CS hold time	-	1	-	T_{SPICLK}

Table 15. SPI Write AC Timing

7.8.2 SPI Read AC Timing

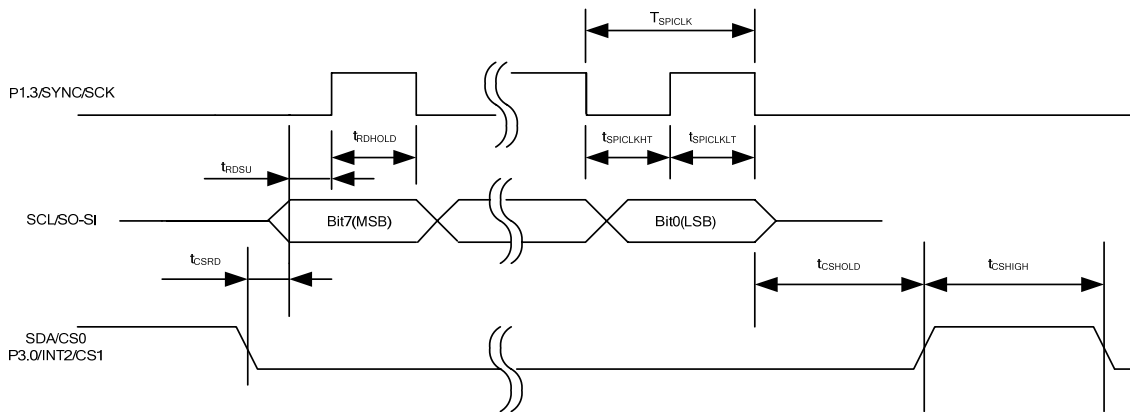

Figure 14 SPI Read AC Timing

Unless specified, Ta = 25°C.

Symbol	Parameter	Min	Typ	Max	Unit
T_{SPICLK}	SPI clock period	4	-	-	SYCLK
$t_{SPICLKHT}$	SPI clock high time	-	1/2	-	T_{SPICLK}
$t_{SPICLKLT}$	SPI clock low time	-	1/2	-	T_{SPICLK}
t_{CSRDL}	CS to data delay time	-	-	10	nsec
t_{RDSU}	SPI read data setup time	10	-	-	nsec
t_{RDHOLD}	SPI read data hold time	10	-	-	nsec
t_{CSHIGH}	CS high time between two consecutive byte transfer	1	-	-	T_{SPICLK}
t_{CSHOLD}	CS hold time	-	1	-	T_{SPICLK}

Table 16. SPI Read AC Timing

7.9 UART AC Timing

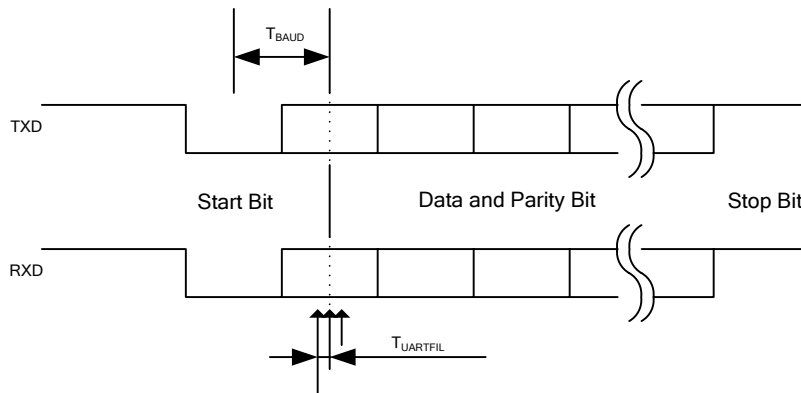

Figure 15 UART AC Timing

Unless specified, $T_a = 25^\circ\text{C}$.

Symbol	Parameter	Min	Typ	Max	Unit
T_{BAUD}	Baud Rate Period	-	57600	-	bit/sec
$T_{UARTFIL}$	UART sampling filter period ⁽¹⁾	-	1/16	-	T_{BAUD}

Table 17. UART AC Timing

Note:

- (1) Each bit including start and stop bit is sampled three times at center of a bit at an interval of $1/16 T_{BAUD}$. If three sampled values do not agree, then UART noise error is generated.

7.10 CAPTURE Input AC Timing

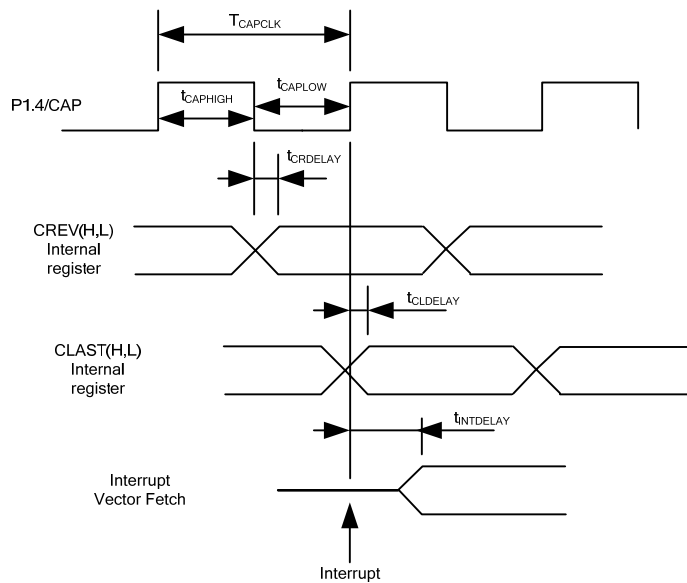

Figure 16 CAPTURE Input AC Timing

Unless specified, $T_a = 25^\circ\text{C}$.

Symbol	Parameter	Min	Typ	Max	Unit
T_{CAPCLK}	CAPTURE input period	8	-	-	SYSCLK
$t_{CAPHIGH}$	CAPTURE input high time	4	-	-	SYSCLK
t_{CAPLOW}	CAPTURE input low time	4	-	-	SYSCLK
$t_{CRDELAY}$	CAPTURE falling edge to capture register latch time	-	-	4	SYSCLK
$t_{CLDELAY}$	CAPTURE rising edge to capture register latch time	-	-	4	SYSCLK
$t_{INTDELAY}$	CAPTURE input interrupt latency time	-	-	4	SYSCLK

Table 18. CAPTURE AC Timing

7.11 JTAG AC Timing

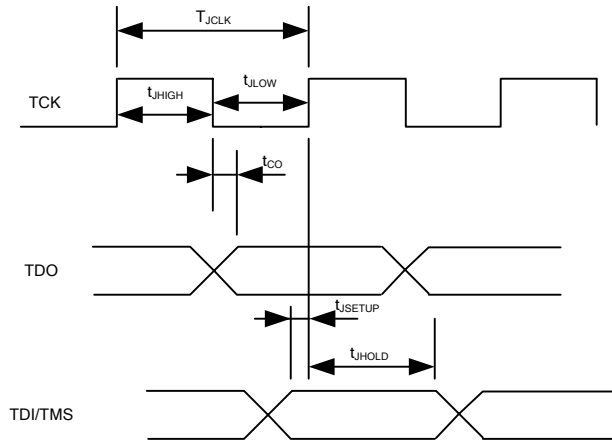

Figure 17 JTAG AC Timing

Unless specified, $T_a = 25^\circ\text{C}$.

Symbol	Parameter	Min	Typ	Max	Unit
T_{JCLK}	TCK Period	-	-	50	MHz
t_{JHIGH}	TCK High Period	10	-	-	nsec
t_{JLOW}	TCK Low Period	10	-	-	nsec
t_{CO}	TCK to TDO propagation delay time	0	-	5	nsec
t_{JSETUP}	TDI/TMS setup time	4	-	-	nsec
t_{JHOLD}	TDI/TMS hold time	0	-	-	nsec

Table 19. JTAG AC Timing

7.12 OTP Programming Timing

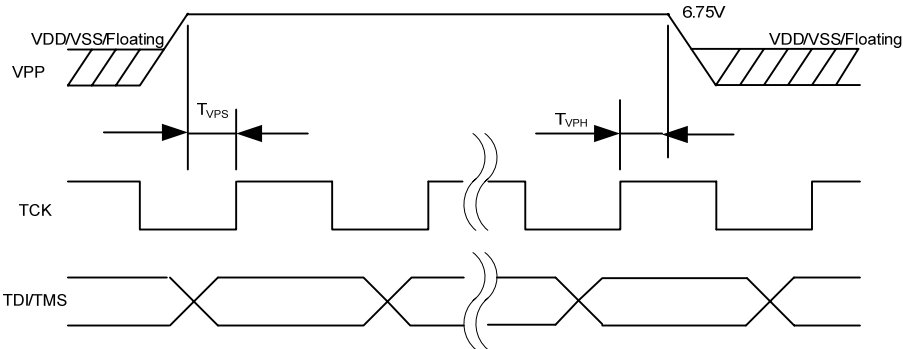

Figure 18 OTP Programming Timing

Unless specified, $T_a = 25^\circ\text{C}$.

Symbol	Parameter	Min	Typ	Max	Unit
T_{VPS}	VPP Setup Time	10	-	-	nsec
T_{VPH}	VPP Hold Time	15	-	-	nsec

Table 20. OTP Programming Timing

8 I/O Structure

The following figure shows the motor PWM and digital I/O structure except the motor PWM output

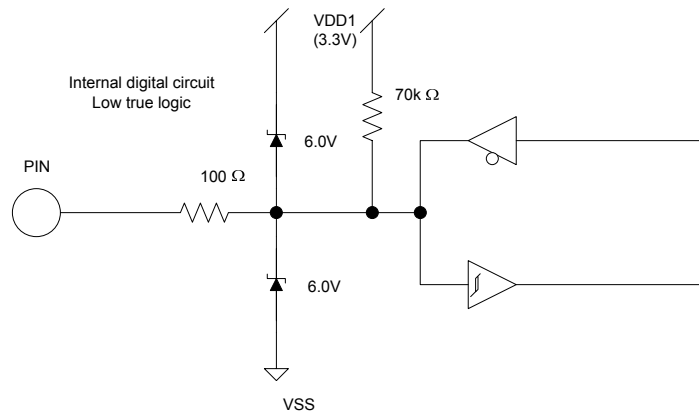

Figure 19 All digital I/O except motor PWM output

The following figure shows RESET and GATEKILL I/O structure.

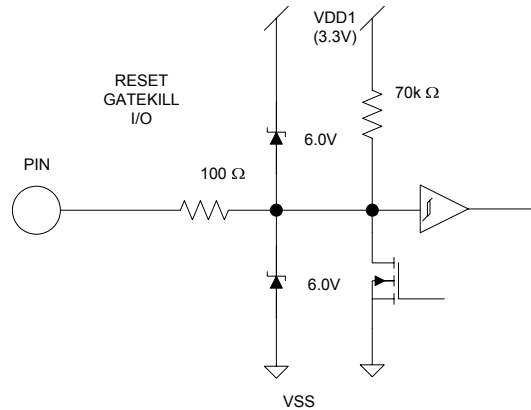

Figure 20 RESET, GATEKILL I/O

The following figure shows the analog input structure.

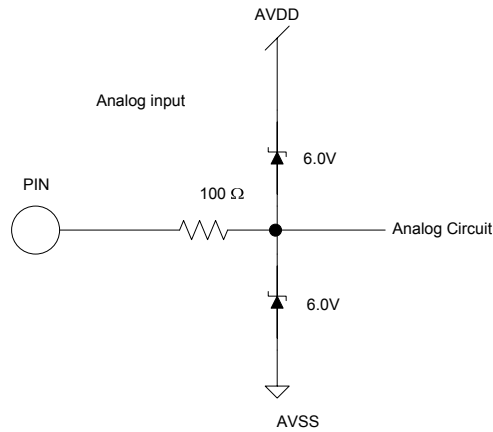

Figure 21 Analog input

The following figure shows all analog operational amplifier output pins and AREF pin I/O structure.

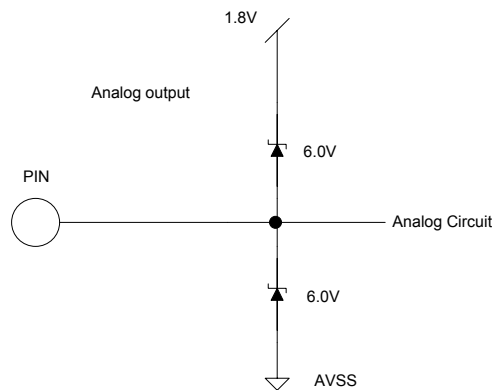

Figure 22 Analog operational amplifier output and AREF I/O structure

The following figure shows the VPP pin I/O structure

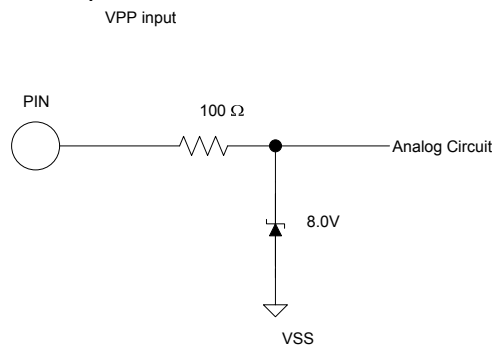

Figure 23 VPP programming pin

The following figure shows the VSS, AVSS and PLLVSS pin structure

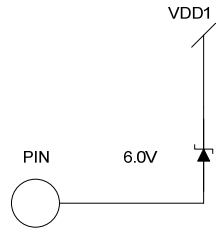

Figure 24 VSS, AVSS and PLLVSS pin structure

The following figure shows the VDD1, VDD2, AVDD and PLLVDD pin structure

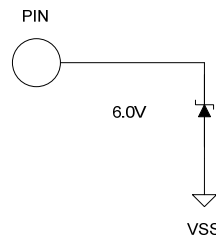

Figure 25 VDD1, VDD2, AVDD and PLLVDD pin structure

The following figure shows the XTAL0 and XTAL1 pins structure

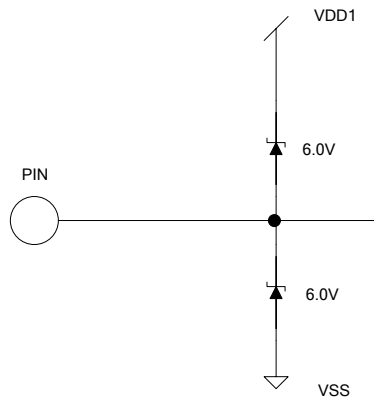

Figure 26 XTAL0/XTAL1 pins structure

9 Pin List

Pin Number	Pin Name	Internal Pull-up /Pull-down	Pin Type	Description
1	XTAL0		I	Crystal input
2	XTAL1		O	Crystal output
3	P1.0/T2		I/O	Discrete programmable I/O or Timer/Counter 2 input
4	P1.1/RXD		I/O	Discrete programmable I/O or UART receive input
5	P1.2/TXD		I/O	Discrete programmable I/O or UART transmit output
6	P1.3/SYNC/SCK		I/O	Discrete programmable I/O or SYNC output or SPI clock output
7	P1.4/CAP		I/O	Discrete programmable I/O or Capture timer input
8	P1.5		I/O	Discrete programmable I/O
9	P1.6		I/O	Discrete programmable I/O
10	P1.7		I/O	Discrete programmable I/O
11	VDD2		P	1.8V digital power
12	VSS		P	Digital common
13	VDD1		P	3.3V digital power
14	P2.0/NMI		I/O	Discrete programmable I/O or Non-maskable Interrupt input
15	P2.1		I/O	Discrete programmable I/O
16	P2.2		I/O	Discrete programmable I/O
17	P2.3		I/O	Discrete programmable I/O
18	P2.4		I/O	Discrete programmable I/O
19	P2.5		I/O	Discrete programmable I/O
20	P2.6/AOPWM0		I/O	Discrete programmable I/O or PWM 0 digital output
21	P2.7/AOPWM1		I/O	Discrete programmable I/O or PWM 1 digital output
22	VDD2		P	1.8V digital power
23	VSS		P	Digital common
24	AIN0		I	Analog input channel 0, 0-1.2V range, needs to be pulled down to AVSS if unused
25	AVDD		P	1.8V analog power
26	AVSS		P	Analog common
27	AIN1		I	Analog input channel 1, 0-1.2V range, needs to be pulled down to AVSS if unused
28	CMEXT		O	Unbuffered 0.6V output. Capacitor needs to be connected.
29	AREF		O	Analog reference voltage output (0.6V)
30	IFB-		I	Single shunt current sensing OP amp input (-)
31	IFB+		I	Single shunt current sensing OP amp input (+)
32	IFBO		O	Single shunt current sensing OP amp output

Pin Number	Pin Name	Internal Pull-up /Pull-down	Pin Type	Description
33	AIN2		I	Analog input channel 2, 0-1.2V range, needs to be pulled down to AVSS if unused
34	AIN3		I	Analog input channel 3, 0-1.2V range, needs to be pulled down to AVSS if unused
35	AIN4		I	Analog input channel 4, 0-1.2V range, needs to be pulled down to AVSS if unused
36	AIN5		I	Analog input channel 5, 0-1.2V range, needs to be pulled down to AVSS if unused
37	AIN6		I	Analog input channel 6, 0-1.2V range, needs to be pulled down to AVSS if unused
38	VDD2		P	1.8V digital power
39	VSS		P	Digital common
40	VDD1		P	3.3V digital power
41	GATEKILL		I	PWM shutdown input, 2- μ sec digital filter, configurable either high or low true.
42	PWMWL	70 k Ω Pull up	O	PWM gate drive for phase W low side, configurable either high or low true
43	PWMWH	70 k Ω Pull up	O	PWM gate drive for phase W high side, configurable either high or low true
44	PWMVL	70 k Ω Pull up	O	PWM gate drive for phase V low side, configurable either high or low true
45	PWMVH	70 k Ω Pull up	O	PWM gate drive for phase V high side, configurable either high or low true
46	PWMUL	70 k Ω Pull up	O	PWM gate drive for phase U low side, configurable either high or low true
47	PWMUH	70 k Ω Pull up	O	PWM gate drive for phase U high side, configurable either high or low true
48	P3.0/INT2/CS1		I/O	Discrete programmable I/O or external interrupt 2 input or SPI Chip Select 1
49	P3.1/AOPWM2		I/O	Discrete programmable I/O or PWM 2 digital output
50	P3.2/INT0		I/O	Discrete programmable I/O or Interrupt 0 input
51	P3.3/INT1		I/O	Discrete programmable I/O or Interrupt 1 input
52	P3.5/T1		I/O	Discrete programmable I/O or Timer/Counter 1
53	VSS		P	Digital common
54	VDD1		P	3.3V digital power
55	SCL/SO-SI/VPP		I/O	I ² C clock output (open drain, need pull up) or SPI data or OTP power supply for programming
56	SDA/CS0		I/O	I ² C data (open drain, need pull up) or SPI Chip Select 0
57	P5.1/TMS		I/O	JTAG test mode select
58	P5.2/TDO		I/O	JTAG test data output
59	P5.3/TDI		I/O	JTAG test data input
60	TCK		I	JTAG test clock

Pin Number	Pin Name	Internal Pull-up /Pull-down	Pin Type	Description
61	TSTMOD	58 kΩ pull down	I	Test mode. Must be tied to VSS. Factory use only
62	RESET		I/O	Reset, low true, Schmitt trigger input
63	PLLVDD		P	1.8V PLL power
64	PLLVSS		P	PLL ground

Table 21. Pin List

10 Package Dimensions

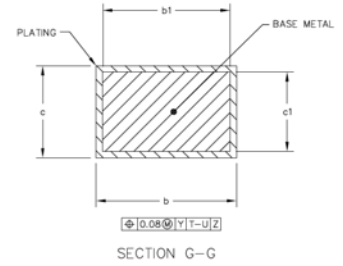
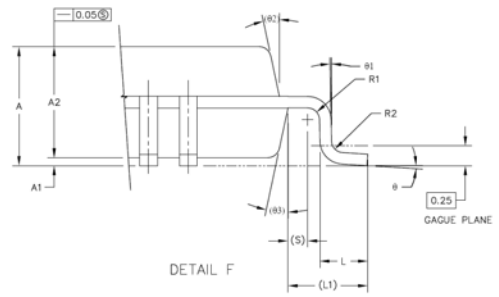
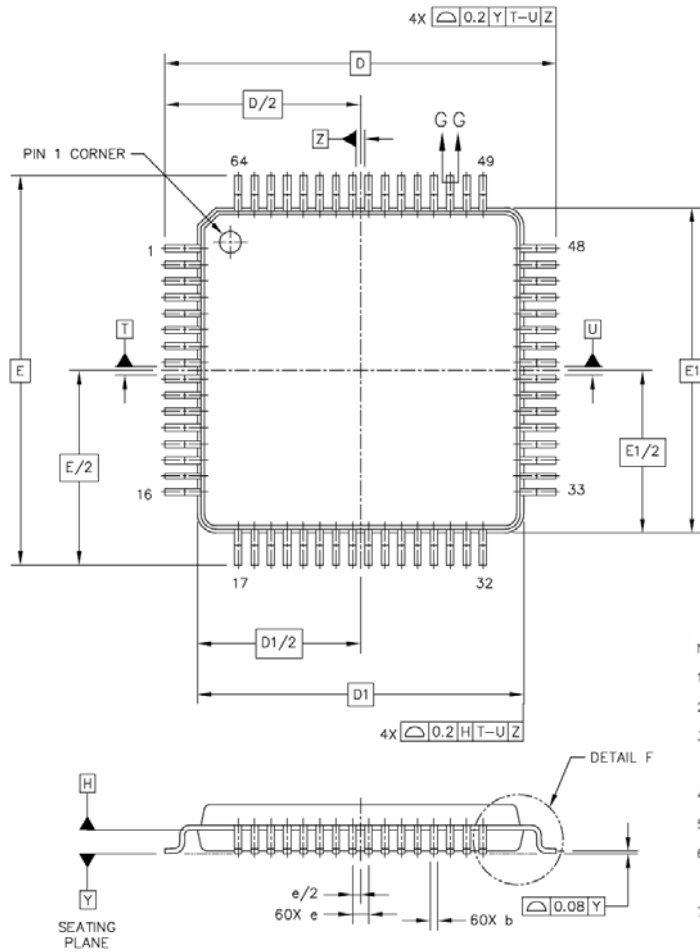

- NOTES:
1. DIMENSIONS ARE IN MILLIMETERS.
 2. INTERPRET DIMENSIONS AND TOLERANCES PER ASME Y14.5M-1994.
 3. DATUM PLANE DATUM H IS LOCATED AT BOTTOM OF LEAD AND IS COINCIDENT WITH THE LEAD WHERE THE LEAD EXITS THE PLASTIC BODY AT THE BOTTOM OF THE PARTING LINE.
 4. DATUM T, U, AND Z TO BE DETERMINED AT DATUM PLANE H.
 5. DIMENSIONS D AND E TO BE DETERMINED AT SEATING PLANE DATUM Y.
 6. DIMENSIONS D1 AND E1 DO NOT INCLUDE MOLD PROTRUSION. ALLOWABLE PROTRUSION IS 0.25 PER SIDE. DIMENSIONS D1 AND E1 DO INCLUDE MOLD MISMATCH AND ARE DETERMINED AT DATUM PLANE DATUM H.
 7. DIMENSION b DOES NOT INCLUDE DAMBAR PROTRUSION. DAMBAR PROTRUSION SHALL NOT CAUSE THE b DIMENSION TO EXCEED 0.35. MINIMUM SPACE BETWEEN PROTRUSION AND ADJACENT LEAD OR PROTRUSION 0.07.

DIM	MIN	MAX	DIM	MIN	MAX	DIM	MIN	MAX
A	---	1.6	L1	1 REF				
A1	0.05	0.15	R1	0.1	0.2			
A2	1.35	1.45	R2	0.1	0.2			
b	0.17	0.27	S	0.2 REF				
b1	0.17	0.23	θ	0°	7°			
c	0.09	0.2	θ1	0°	---			
c1	0.09	0.16	θ2	12° REF				
D		12 BSC	θ3	12° REF				
D1		10 BSC						
e		0.5 BSC						
E		12 BSC						
E1		10 BSC						
L	0.45	0.75						

11 Part Marking Information

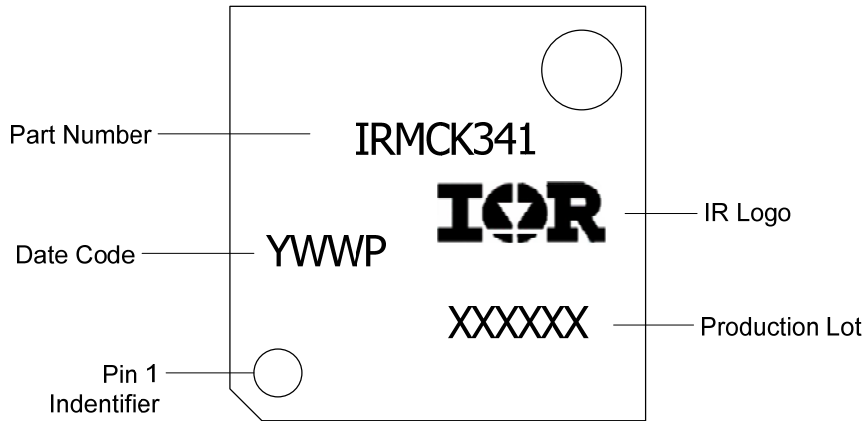

12 Order Information

Lead-Free Part in 64-lead QFP
Moisture Sensitivity Rating – MSL3

Part number	Order quantities
IRMCK341TR	1500 parts on tape and reel in dry pack
IRMCK341TY	1600 parts on trays (160 parts per tray) in dry pack

International
IR Rectifier

The LQFP-64 is MSL3 qualified
 This product has been designed and qualified for the industrial level
 Qualification standards can be found at www.irf.com <<http://www.irf.com>>
IR WORLD HEADQUARTERS: 233 Kansas St., El Segundo, California 90245, Tel: (310) 252-7105
 Data and specifications subject to change without notice. 12/25/2007

www.irf.com

Looking for pricing, stock, or lifecycle information?

Click below to explore more details on WIN SOURCE:

 [View IRMCK341TR on WIN SOURCE](#)

 [Infineon Technologies](#) Information

Optimize Your Supply Chain with WIN SOURCE Solutions

-  Global Sourcing Solution
-  Obsolete Management
-  Cost Control Management
-  Shortage Management
-  Alternative Solution
-  Excess Inventory Management