



# THE DATASHEET OF IRGPS40B120UDP



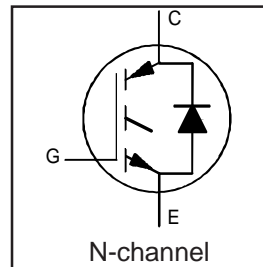
# IRGPS40B120UDP

INSULATED GATE BIPOLAR TRANSISTOR WITH  
ULTRAFAST SOFT RECOVERY DIODE

UltraFast Co-Pack IGBT

## Features

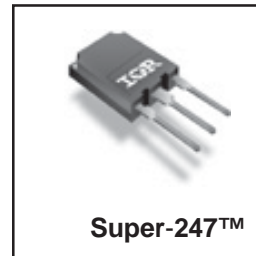
- Non Punch Through IGBT Technology.
- Low Diode VF.
- 10µs Short Circuit Capability.
- Square RBSOA.
- Ultrasoft Diode Reverse Recovery Characteristics.
- Positive VCE (on) Temperature Coefficient.
- Super-247 Package.
- Lead-Free



$V_{CES} = 1200V$
$V_{CE(on)} \text{ typ.} = 3.12V$
@ $V_{GE} = 15V,$
$I_{CE} = 40A, T_j = 25^\circ C$

## Benefits

- Benchmark Efficiency for Motor Control.
- Rugged Transient Performance.
- Low EMI.
- Significantly Less Snubber Required
- Excellent Current Sharing in Parallel Operation.



## Absolute Maximum Ratings

	Parameter	Max.	Units
$V_{CES}$	Collector-to-Emitter Voltage	1200	V
$I_C @ T_C = 25^\circ C$	Continuous Collector Current	80	A
$I_C @ T_C = 100^\circ C$	Continuous Collector Current	40	
$I_{CM}$	Pulsed Collector Current	160	
$I_{LM}$	Clamped Inductive Load Current <sup>Ⓞ</sup>	160	
$I_F @ T_C = 25^\circ C$	Diode Continuous Forward Current	80	
$I_F @ T_C = 100^\circ C$	Diode Continuous Forward Current	40	
$I_{FM}$	Diode Maximum Forward Current	160	
$V_{GE}$	Gate-to-Emitter Voltage	$\pm 20$	V
$P_D @ T_C = 25^\circ C$	Maximum Power Dissipation	595	W
$P_D @ T_C = 100^\circ C$	Maximum Power Dissipation	238	
$T_J$	Operating Junction and	-55 to +150	°C
$T_{STG}$	Storage Temperature Range		
	Soldering Temperature, for 10 sec.	300 (0.063 in. (1.6mm) from case)	

## Thermal Resistance

	Parameter	Min.	Typ.	Max.	Units
$R_{\theta JC}$	Junction-to-Case - IGBT	—	—	0.20	°C/W
$R_{\theta JC}$	Junction-to-Case - Diode	—	—	0.83	
$R_{\theta CS}$	Case-to-Sink, flat, greased surface	—	0.24	—	
$R_{\theta JA}$	Junction-to-Ambient, typical socket mount	—	—	40	
	Recommended Clip Force	20 (2)	—	—	N(kgf)
Wt	Weight	—	6.0 (0.21)	—	g (oz)
Le	Internal Emitter Inductance (5mm from package)	—	13	—	nH

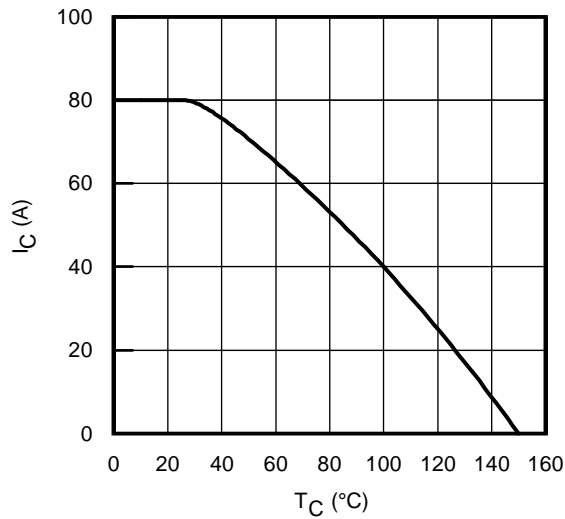
# IRGPS40B120UDP

## Electrical Characteristics @ T<sub>J</sub> = 25°C (unless otherwise specified)

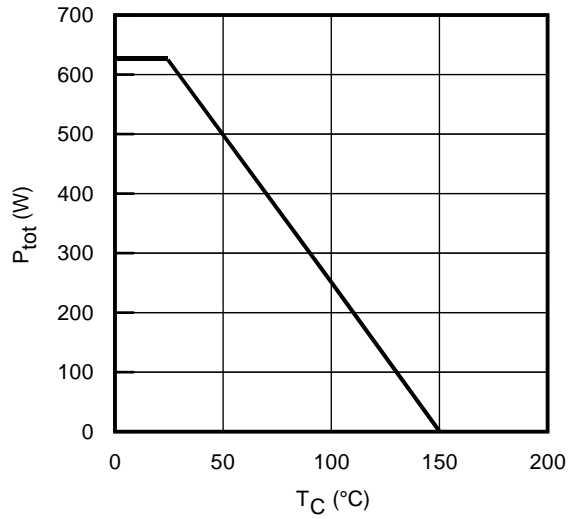
	Parameter	Min.	Typ.	Max.	Units	Conditions	Ref.Fig.
V <sub>(BR)CES</sub>	Collector-to-Emitter Breakdown Voltage	1200	—	—	V	V <sub>GE</sub> = 0V, I <sub>C</sub> = 500μA	
ΔV <sub>(BR)CES</sub> /ΔT <sub>J</sub>	Temperature Coeff. of Breakdown Voltage	—	0.40	—	V/°C	V <sub>GE</sub> = 0V, I <sub>C</sub> = 1.0mA, (25°C-125°C)	
V <sub>CE(on)</sub>	Collector-to-Emitter Saturation Voltage	—	3.12	3.40	V	I <sub>C</sub> = 40A I <sub>C</sub> = 50A I <sub>C</sub> = 40A, T <sub>J</sub> = 125°C I <sub>C</sub> = 50A, T <sub>J</sub> = 125°C	5, 6
		—	3.39	3.70			7, 9
		—	3.88	4.30			10
		—	4.24	4.70			11
V <sub>GE(th)</sub>	Gate Threshold Voltage	4.0	5.0	6.0		V <sub>CE</sub> = V <sub>GE</sub> , I <sub>C</sub> = 250μA	9,10
ΔV <sub>GE(th)</sub> /ΔT <sub>J</sub>	Temperature Coeff. of Threshold Voltage	—	-12	—	mV/°C	V <sub>CE</sub> = V <sub>GE</sub> , I <sub>C</sub> = 1.0mA, (25°C-125°C)	11, 12
g <sub>fe</sub>	Forward Transconductance	—	30.5	—	S	V <sub>CE</sub> = 50V, I <sub>C</sub> = 40A, PW=80μs	
I <sub>CES</sub>	Zero Gate Voltage Collector Current	—	—	500	μA	V <sub>GE</sub> = 0V, V <sub>CE</sub> = 1200V	
		—	420	1200		V <sub>GE</sub> = 0V, V <sub>CE</sub> = 1200V, T <sub>J</sub> = 125°C	
V <sub>FM</sub>	Diode Forward Voltage Drop	—	2.03	2.40	V	I <sub>C</sub> = 40A	8
		—	2.17	2.60		I <sub>C</sub> = 50A	
		—	2.26	2.68		I <sub>C</sub> = 40A, T <sub>J</sub> = 125°C	
		—	2.46	2.95		I <sub>C</sub> = 50A, T <sub>J</sub> = 125°C	
I <sub>GES</sub>	Gate-to-Emitter Leakage Current	—	—	±100	nA	V <sub>GE</sub> = ±20V	

## Switching Characteristics @ T<sub>J</sub> = 25°C (unless otherwise specified)

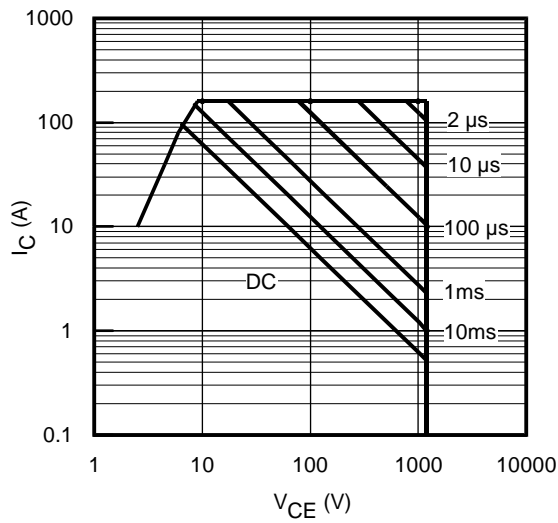
	Parameter	Min.	Typ.	Max.	Units	Conditions	Ref.Fig.
Q <sub>g</sub>	Total Gate Charge (turn-on)	—	340	510	nC	I <sub>C</sub> = 40A	23
Q <sub>ge</sub>	Gate - Emitter Charge (turn-on)	—	40	60		V <sub>CC</sub> = 600V	CT1
Q <sub>gc</sub>	Gate - Collector Charge (turn-on)	—	165	248		V <sub>GE</sub> = 15V	
E <sub>on</sub>	Turn-On Switching Loss	—	1400	1750	μJ	I <sub>C</sub> = 40A, V <sub>CC</sub> = 600V	CT4
E <sub>off</sub>	Turn-Off Switching Loss	—	1650	2050		V <sub>GE</sub> = 15V, R <sub>G</sub> = 4.7Ω, L = 200μH	WF1
E <sub>tot</sub>	Total Switching Loss	—	3050	3800	μJ	L <sub>s</sub> = 150nH T <sub>J</sub> = 25°C	WF2
E <sub>on</sub>	Turn-On Switching Loss	—	1950	2300		T <sub>J</sub> = 125°C	13,15
E <sub>off</sub>	Turn-Off Switching Loss	—	2200	2950	μJ	Energy losses include "tail" and diode reverse recovery.	
E <sub>tot</sub>	Total Switching Loss	—	4150	5250			
t <sub>d(on)</sub>	Turn-On Delay Time	—	76	99	ns	I <sub>C</sub> = 40A, V <sub>CC</sub> = 600V	14, 16
t <sub>r</sub>	Rise Time	—	39	55		V <sub>GE</sub> = 15V, R <sub>G</sub> = 4.7Ω, L = 200μH	CT4
t <sub>d(off)</sub>	Turn-Off Delay Time	—	332	365		L <sub>s</sub> = 150nH, T <sub>J</sub> = 125°C	WF1
t <sub>f</sub>	Fall Time	—	25	33			WF2
C <sub>ies</sub>	Input Capacitance	—	4300	—	pF	V <sub>GE</sub> = 0V	22
C <sub>oes</sub>	Output Capacitance	—	330	—		V <sub>CC</sub> = 30V	
C <sub>res</sub>	Reverse Transfer Capacitance	—	160	—		f = 1.0MHz	
RBSOA	Reverse Bias Safe Operating Area	FULL SQUARE				T <sub>J</sub> = 150°C, I <sub>C</sub> = 160A, V <sub>p</sub> = 1200V V <sub>CC</sub> = 1000V, V <sub>GE</sub> = +15V to 0V R <sub>G</sub> = 4.7Ω	4 CT2
SCSOA	Short Circuit Safe Operating Area	10	—	—	μs	T <sub>J</sub> = 150°C, V <sub>p</sub> = 1200V V <sub>CC</sub> = 900V, V <sub>GE</sub> = +15V to 0V, R <sub>G</sub> = 4.7Ω	CT3 WF4
E <sub>rec</sub>	Reverse Recovery energy of the diode	—	3346	—	μJ	T <sub>J</sub> = 125°C	17,18,19
t <sub>rr</sub>	Diode Reverse Recovery time	—	180	—	ns	V <sub>CC</sub> = 600V, I <sub>F</sub> = 60A, L = 200μH	20, 21
I <sub>rr</sub>	Diode Peak Reverse Recovery Current	—	50	—	A	V <sub>GE</sub> = 15V, R <sub>G</sub> = 4.7Ω, L <sub>s</sub> = 150nH	CT4, WF3



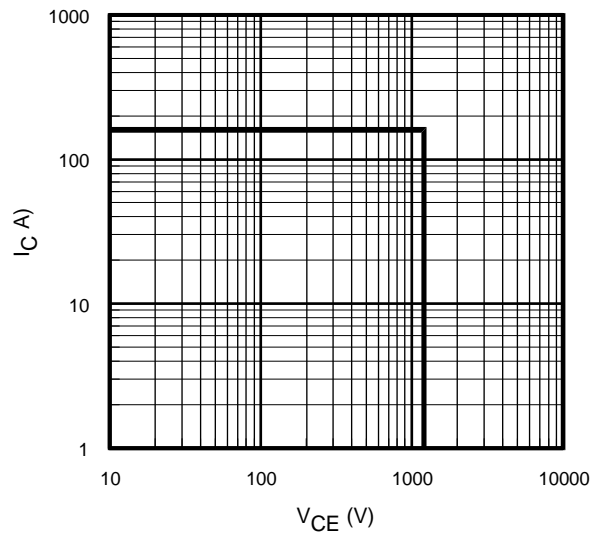
**Fig. 1** - Maximum DC Collector Current vs. Case Temperature



**Fig. 2** - Power Dissipation vs. Case Temperature

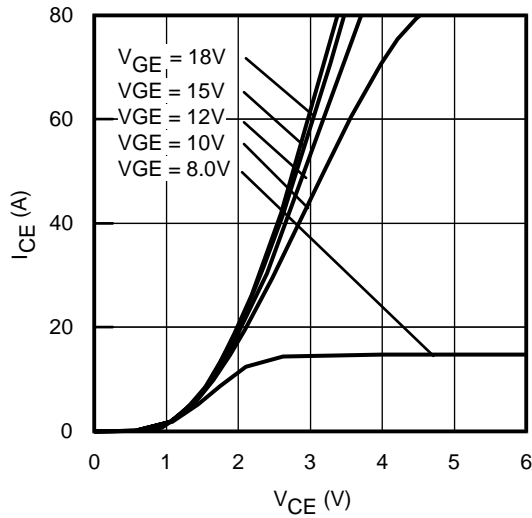


**Fig. 3** - Forward SOA  
 $T_C = 25^\circ\text{C}$ ;  $T_{JS} \leq 150^\circ\text{C}$

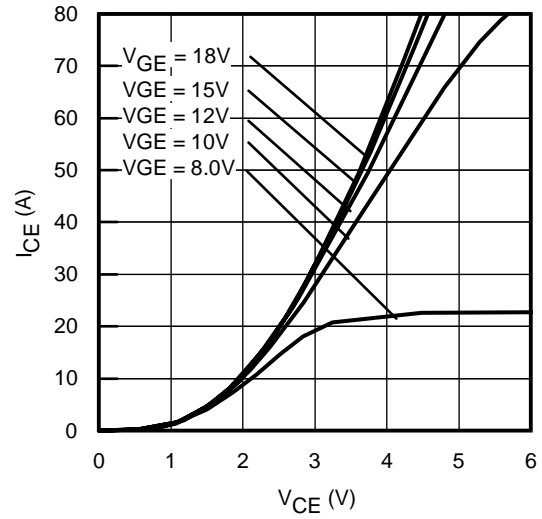


**Fig. 4** - Reverse Bias SOA  
 $T_J = 150^\circ\text{C}$ ;  $V_{GE} = 15\text{V}$

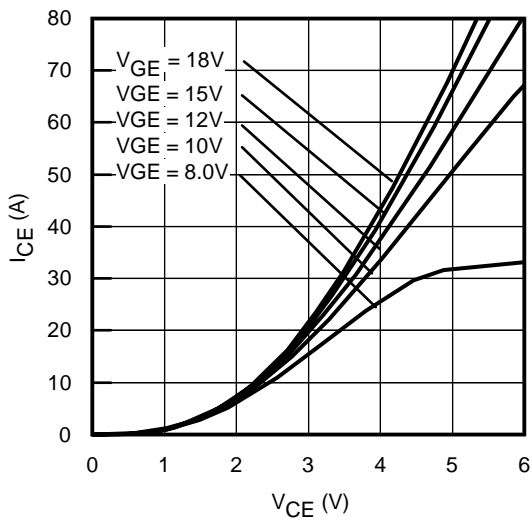
# IRGPS40B120UDP



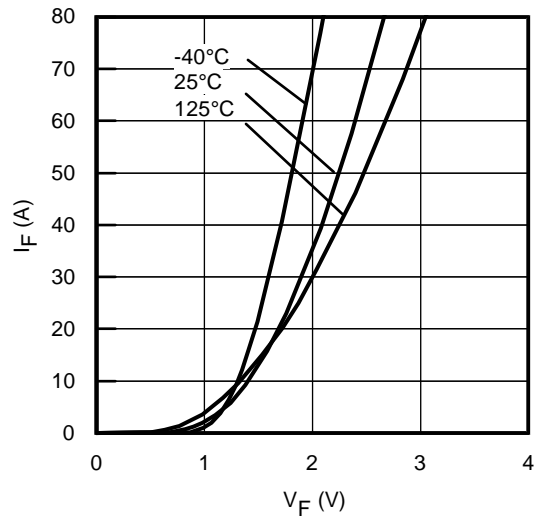
**Fig. 5** - Typ. IGBT Output Characteristics  
 $T_J = -40^\circ\text{C}$ ;  $t_p = 80\mu\text{s}$



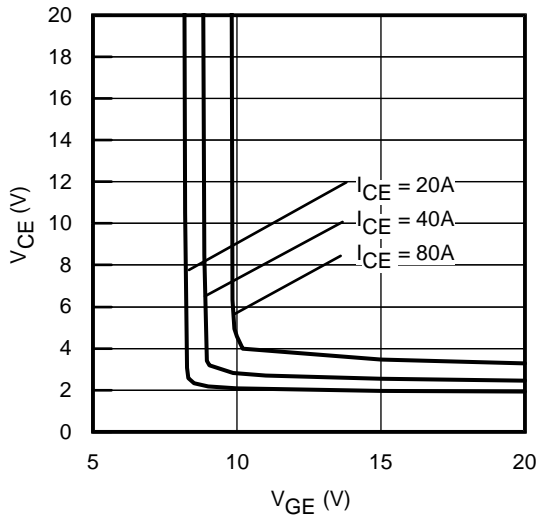
**Fig. 6** - Typ. IGBT Output Characteristics  
 $T_J = 25^\circ\text{C}$ ;  $t_p = 80\mu\text{s}$



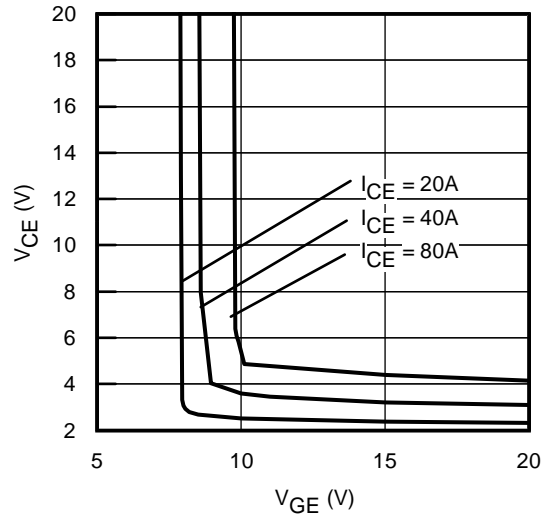
**Fig. 7** - Typ. IGBT Output Characteristics  
 $T_J = 125^\circ\text{C}$ ;  $t_p = 80\mu\text{s}$



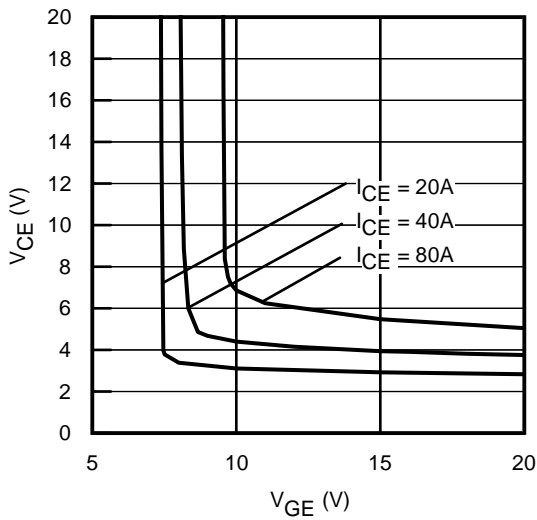
**Fig. 8** - Typ. Diode Forward Characteristics  
 $t_p = 80\mu\text{s}$



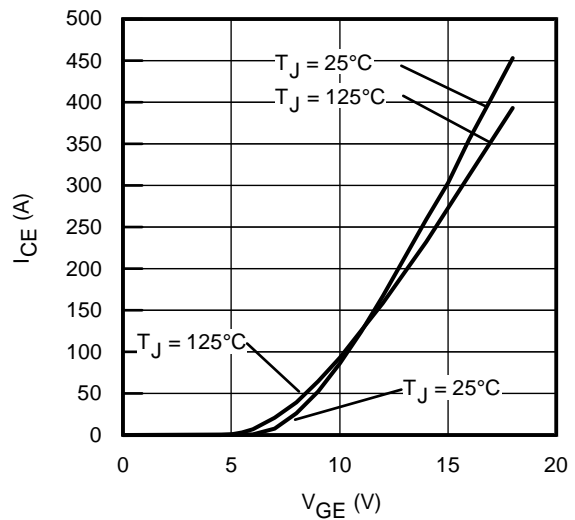
**Fig. 9** - Typical  $V_{CE}$  vs.  $V_{GE}$   
 $T_J = -40^\circ\text{C}$



**Fig. 10** - Typical  $V_{CE}$  vs.  $V_{GE}$   
 $T_J = 25^\circ\text{C}$

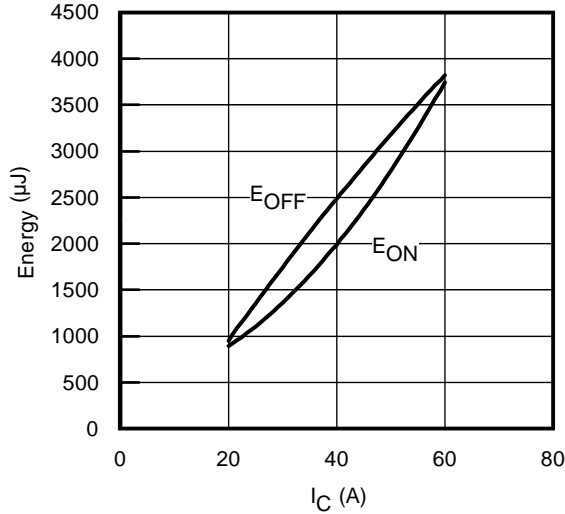


**Fig. 11** - Typical  $V_{CE}$  vs.  $V_{GE}$   
 $T_J = 125^\circ\text{C}$

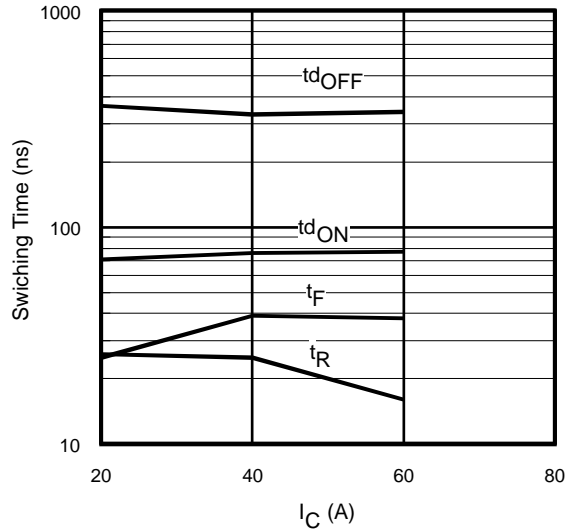


**Fig. 12** - Typ. Transfer Characteristics  
 $V_{CE} = 50\text{V}$ ;  $t_p = 10\mu\text{s}$

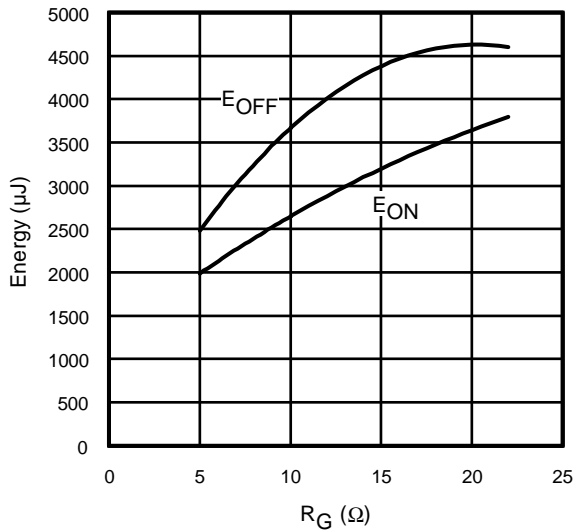
# IRGPS40B120UDP



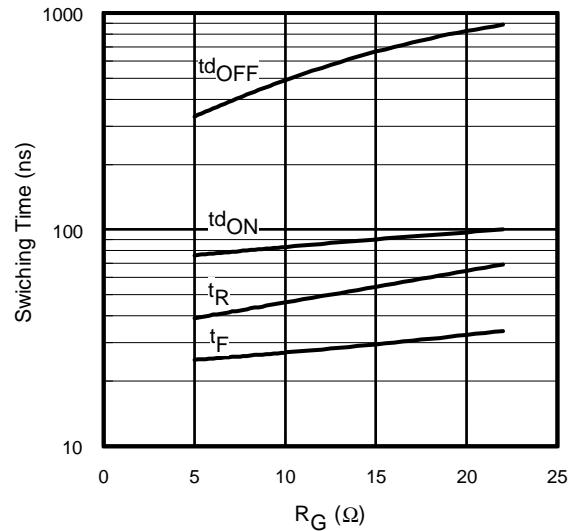
**Fig. 13** - Typ. Energy Loss vs.  $I_C$   
 $T_J = 125^\circ\text{C}$ ;  $L=200\mu\text{H}$ ;  $V_{CE}= 600\text{V}$   
 $R_G= 4.7\Omega$ ;  $V_{GE}= 15\text{V}$



**Fig. 14** - Typ. Switching Time vs.  $I_C$   
 $T_J = 125^\circ\text{C}$ ;  $L=200\mu\text{H}$ ;  $V_{CE}= 600\text{V}$   
 $R_G= 4.7\Omega$ ;  $V_{GE}= 15\text{V}$

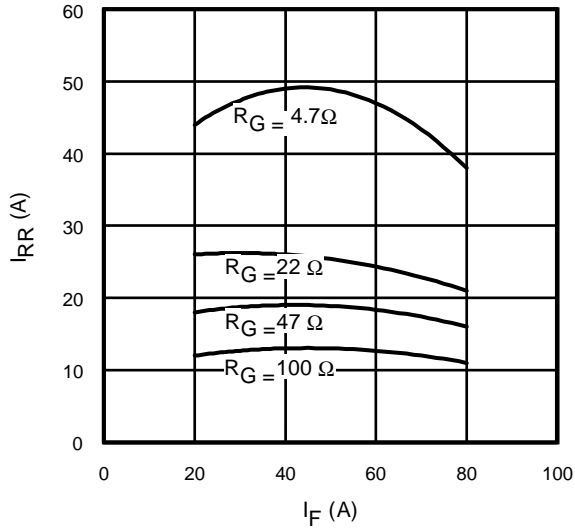


**Fig. 15** - Typ. Energy Loss vs.  $R_G$   
 $T_J = 125^\circ\text{C}$ ;  $L=200\mu\text{H}$ ;  $V_{CE}= 600\text{V}$   
 $I_{CE}= 40\text{A}$ ;  $V_{GE}= 15\text{V}$

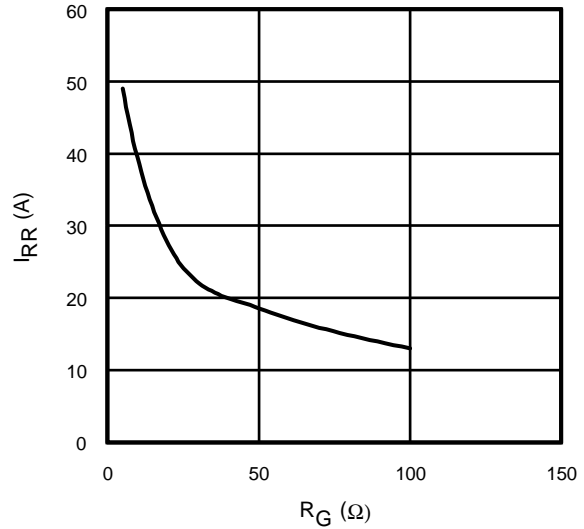


**Fig. 16** - Typ. Switching Time vs.  $R_G$   
 $T_J = 125^\circ\text{C}$ ;  $L=200\mu\text{H}$ ;  $V_{CE}= 600\text{V}$   
 $I_{CE}= 40\text{A}$ ;  $V_{GE}= 15\text{V}$

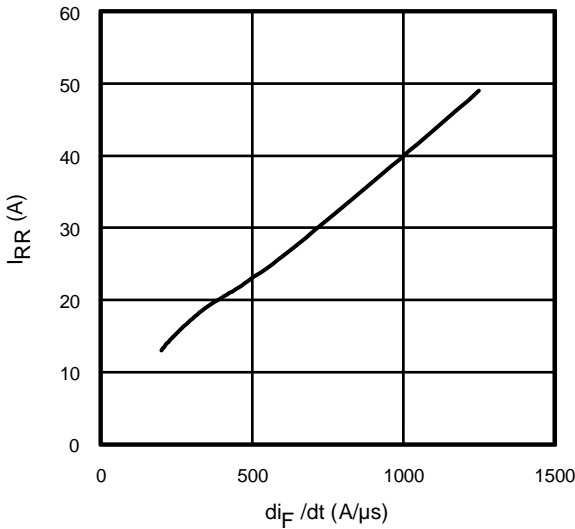
# IRGPS40B120UDP



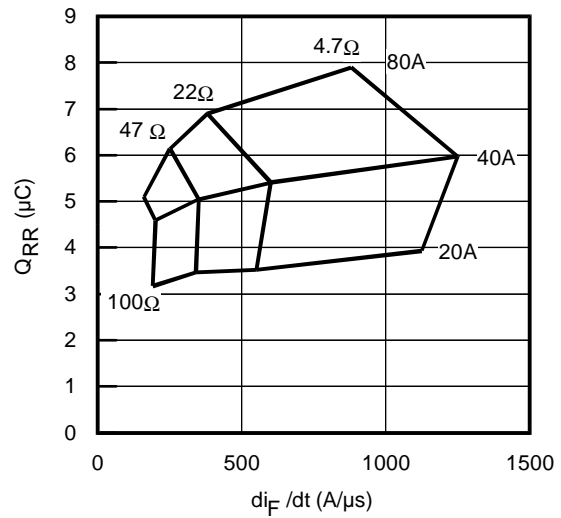
**Fig. 17** - Typical Diode  $I_{RR}$  vs.  $I_F$   
 $T_J = 125^\circ\text{C}$



**Fig. 18** - Typical Diode  $I_{RR}$  vs.  $R_G$   
 $T_J = 125^\circ\text{C}; I_F = 40\text{A}$

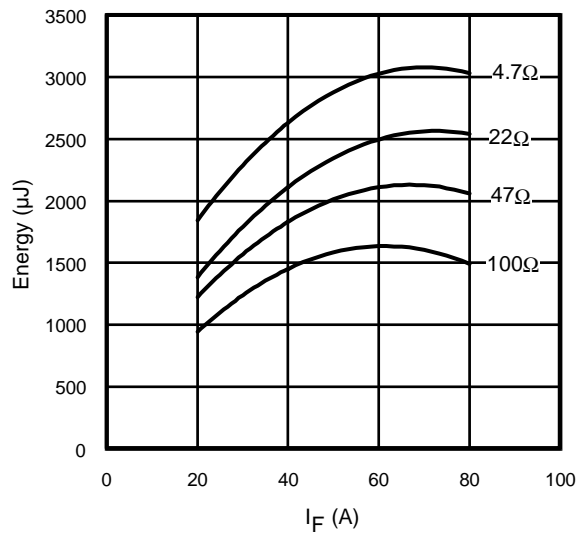


**Fig. 19**- Typical Diode  $I_{RR}$  vs.  $di_F/dt$   
 $V_{CC} = 600\text{V}; V_{GE} = 15\text{V};$   
 $I_{CE} = 40\text{A}; T_J = 125^\circ\text{C}$

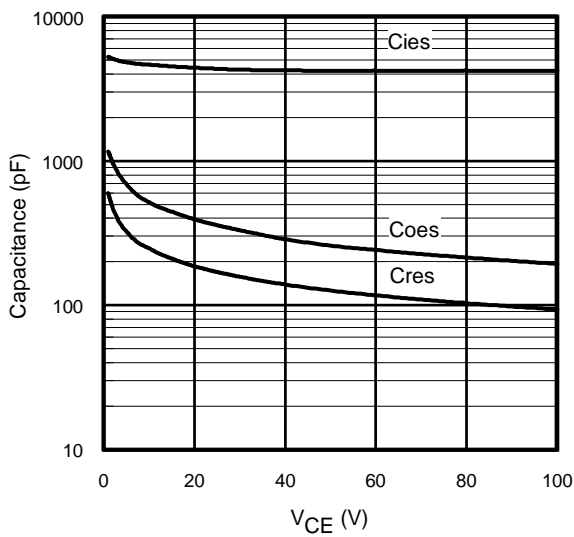


**Fig. 20** - Typical Diode  $Q_{RR}$   
 $V_{CC} = 600\text{V}; V_{GE} = 15\text{V}; T_J = 125^\circ\text{C}$

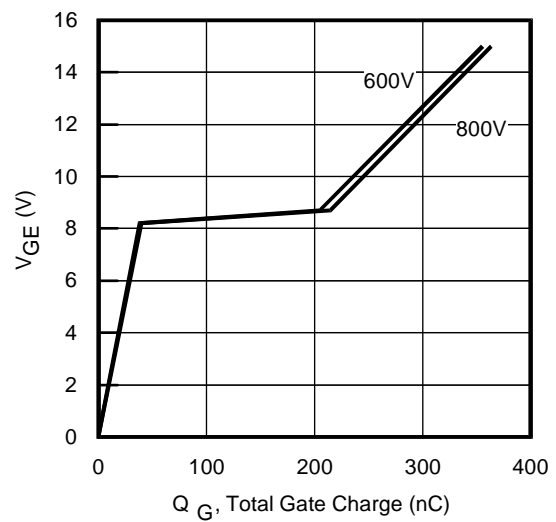
# IRGPS40B120UDP



**Fig. 21** - Typical Diode  $E_{RR}$  vs.  $I_F$   
 $T_J = 125^\circ\text{C}$



**Fig. 22**- Typ. Capacitance vs.  $V_{CE}$   
 $V_{GE} = 0V$ ;  $f = 1\text{MHz}$



**Fig. 23** - Typical Gate Charge vs.  $V_{GE}$   
 $I_{CE} = 40A$ ;  $L = 600\mu\text{H}$

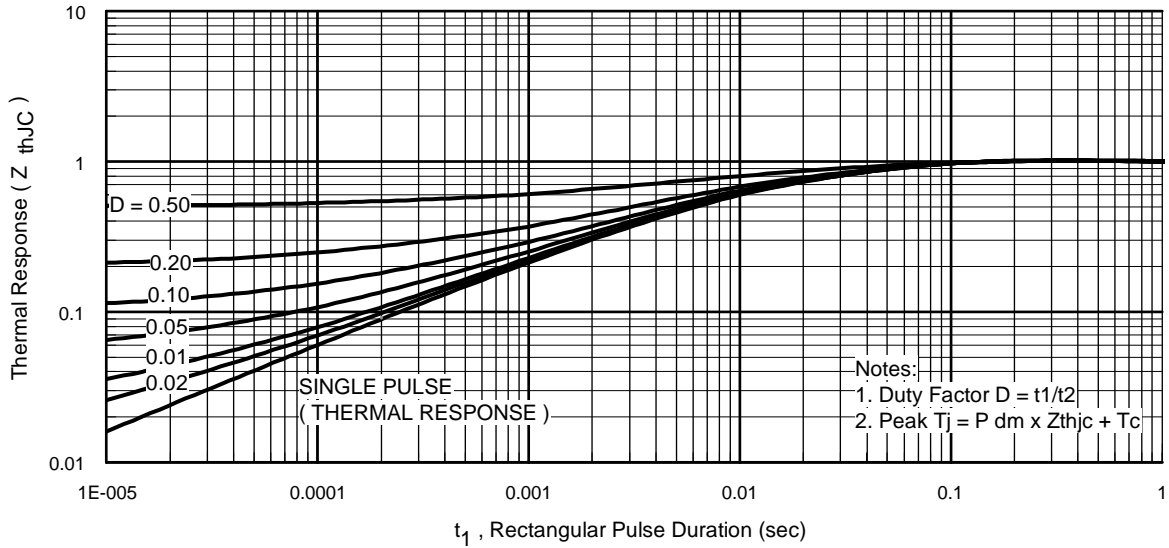


Fig 24. Normalized Transient Thermal Impedance, Junction-to-Case (IGBT)

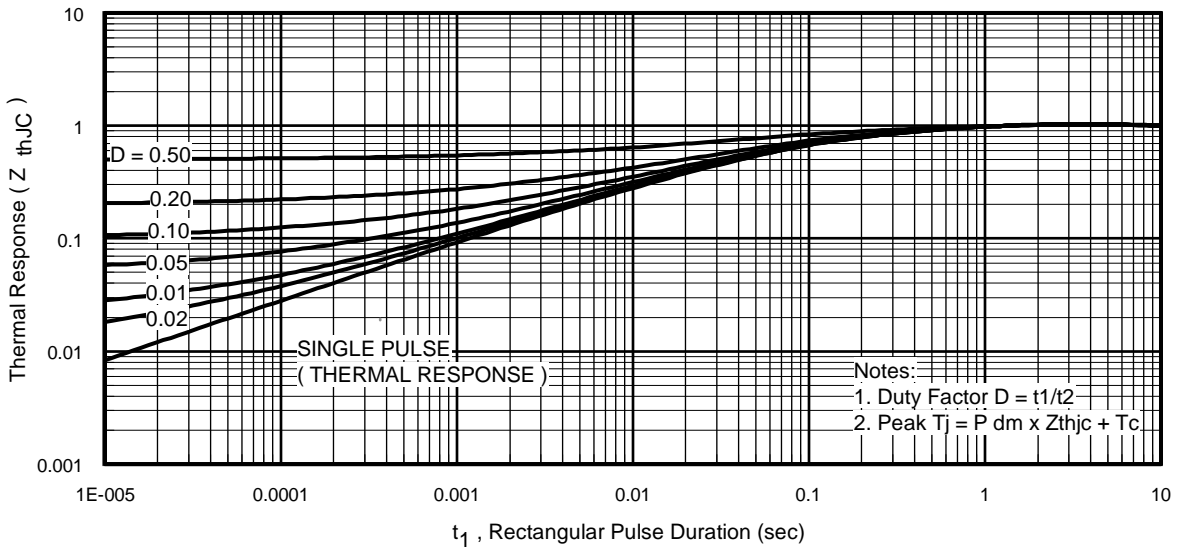
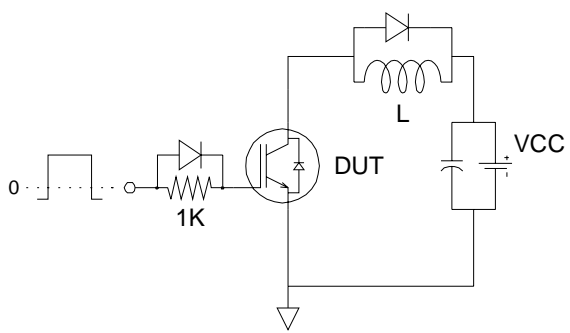


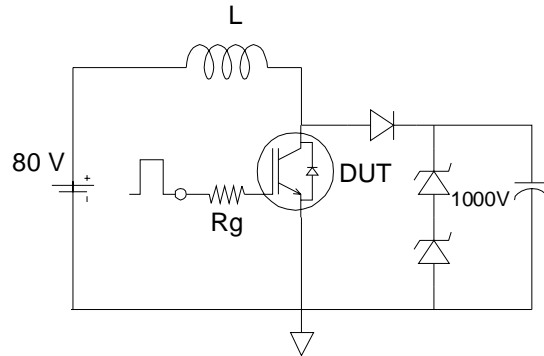
Fig 25. Normalized Transient Thermal Impedance, Junction-to-Case (DIODE)

# IRGPS40B120UDP

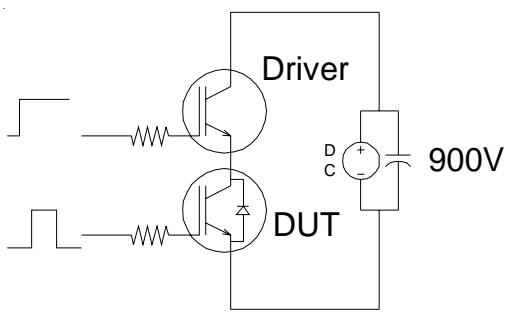
International  
**IR** Rectifier



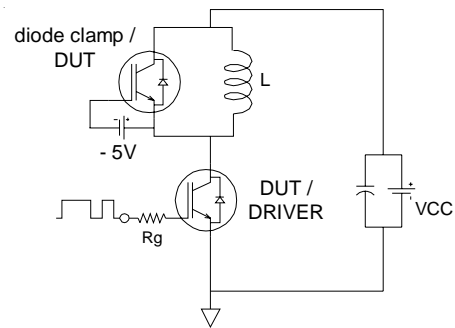
**Fig.C.T.1** - Gate Charge Circuit (turn-on)



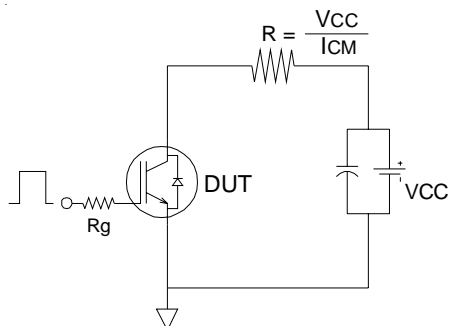
**Fig.C.T.2** - RBSOA Circuit



**Fig.C.T.3** - RBSOA Circuit



**Fig.C.T.4** - RBSOA Circuit



**Fig.C.T.5** - RBSOA Circuit

# IRGPS40B120UDP

Fig. WF.1 - Typ. Turn-off Loss Waveform  
 @  $T_j=125^\circ\text{C}$  using Fig. CT.4

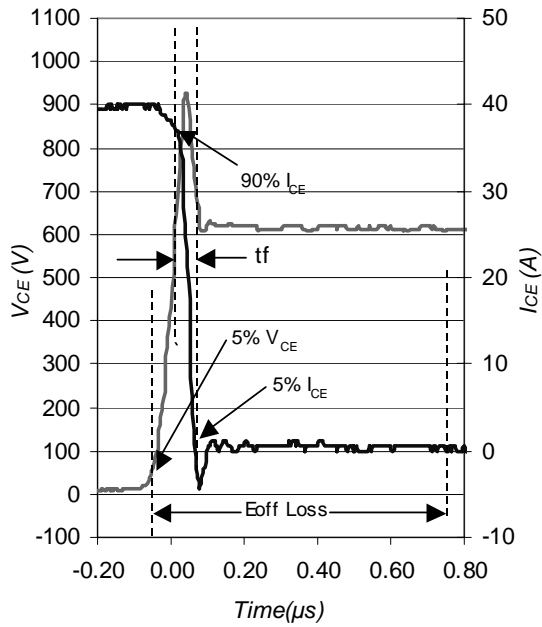


Fig. WF.2 - Typ. Turn-on Loss Waveform  
 @  $T_j=125^\circ\text{C}$  using Fig. CT.4

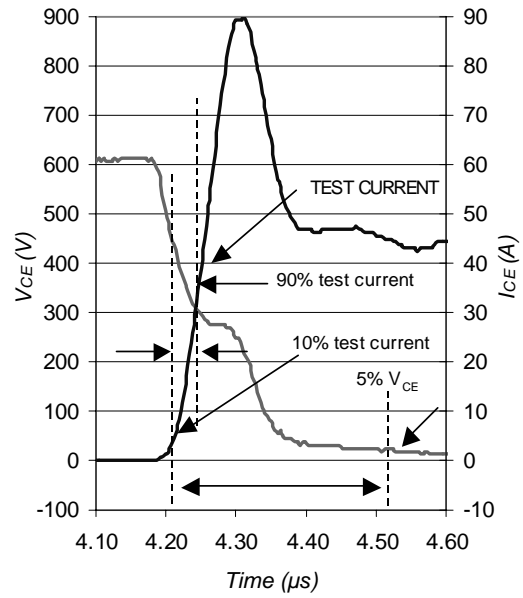


Fig. WF.3 - Typ. Diode Recovery Waveform  
 @  $T_j=125^\circ\text{C}$  using Fig. CT.4

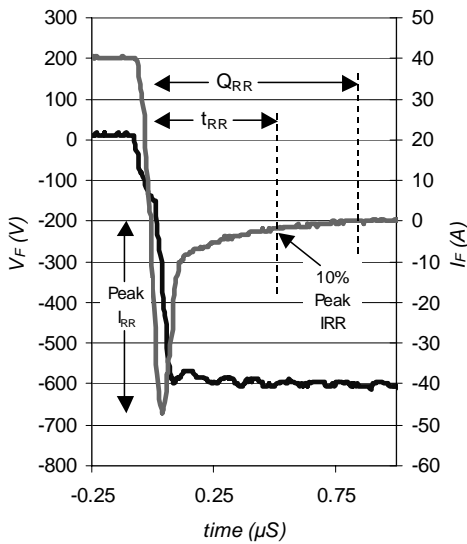
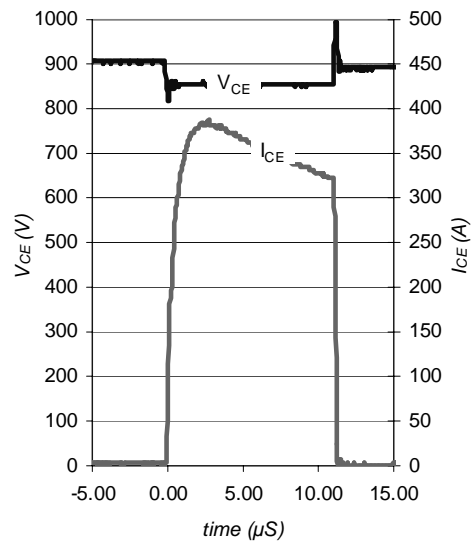


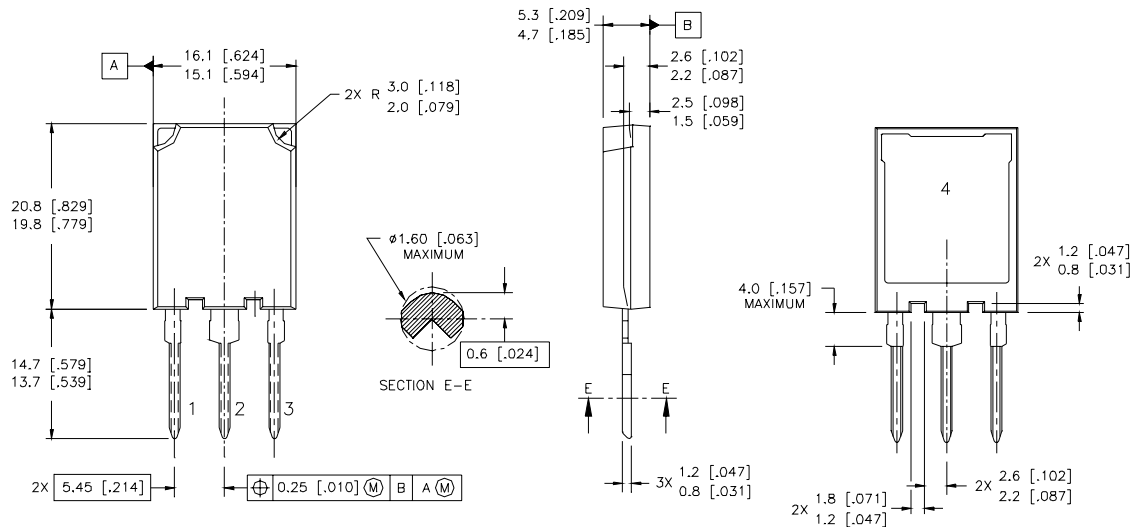
Fig. WF.4 - Typ. S.C. Waveform  
 @  $T_C=150^\circ\text{C}$  using Fig. CT.3



# IRGPS40B120UDP

## Case Outline and Dimensions — Super-247

International  
**IR** Rectifier



**NOTES:**

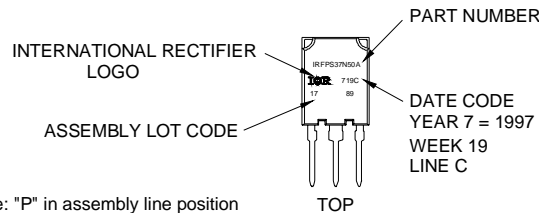
1. DIMENSIONS & TOLERANCING PER ASME Y14.5M-1994
2. CONTROLLING DIMENSION: MILLIMETER
3. DIMENSIONS ARE SHOWN IN MILLIMETRES [INCHES]

**LEAD ASSIGNMENTS**

MOSFET	IGBT
1 - GATE	1 - GATE
2 - DRAIN	2 - COLLECTOR
3 - SOURCE	3 - EMITTER
4 - DRAIN	4 - COLLECTOR

## Super-247 (TO-274AA) Part Marking Information

EXAMPLE: THIS IS AN IRFP37N50A WITH  
ASSEMBLY LOT CODE 1789  
ASSEMBLED ON WW 19, 1997  
IN THE ASSEMBLY LINE "C"



Note: "P" in assembly line position indicates "Lead-Free"

①  $V_{CC} = 80\% (V_{CES})$ ,  $V_{GE} = 20V$ ,  $L = 100 \mu H$ ,  $R_G = 4.7\Omega$ .

Data and specifications subject to change without notice.  
This product has been designed and qualified for the industrial market.  
Qualification Standards can be found on IR's Web site.

International  
**IR** Rectifier

**IR WORLD HEADQUARTERS:** 233 Kansas St., El Segundo, California 90245, USA Tel: (310) 252-7105  
TAC Fax: (310) 252-7903

Visit us at [www.irf.com](http://www.irf.com) for sales contact information.11/04

## Looking for pricing, stock, or lifecycle information?

Click below to explore more details on WIN SOURCE:

 [View IRGPS40B120UDP](#) on WIN SOURCE

 [Infineon Technologies](#) Information

## Optimize Your Supply Chain with WIN SOURCE Solutions

-  Global Sourcing Solution
-  Obsolete Management
-  Cost Control Management
-  Shortage Management
-  Alternative Solution
-  Excess Inventory Management