



# THE DATASHEET OF IRGI4056

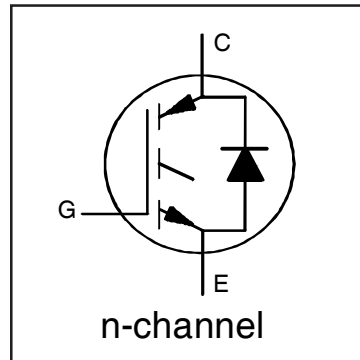


# IRGI4056DPbF

## INSULATED GATE BIPOLAR TRANSISTOR WITH ULTRAFAST SOFT RECOVERY DIODE

### Features

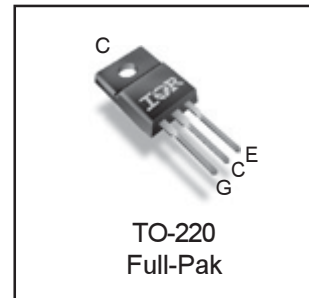
- Low  $V_{CE(ON)}$  trench IGBT technology
- Low switching losses
- 5  $\mu$ S short circuit SOA
- Square RBSOA
- 100% of the parts tested for  $I_{LM}$  ①
- Positive  $V_{CE(ON)}$  temperature co-efficient
- Ultra fast soft recovery co-pak diode
- Tight parameter distribution
- Lead-Free package



$V_{CES} = 600V$
$I_C = 9.0A, T_C = 100^\circ C$
$t_{SC} \geq 5\mu s, T_{J(max)} = 150^\circ C$
$V_{CE(on)} \text{ typ.} = 1.44V$

### Benefits

- High efficiency in a wide range of applications
- Suitable for a wide range of switching frequencies due to Low  $V_{CE(ON)}$  and low switching losses
- Rugged transient performance for increased reliability
- Excellent current sharing in parallel operation
- Low EMI



<b>G</b>	<b>C</b>	<b>E</b>
Gate	Collector	Emitter

### Absolute Maximum Ratings

	Parameter	Max.	Units
$V_{CES}$	Collector-to-Emitter Voltage	600	V
$I_C @ T_C = 25^\circ C$	Continuous Collector Current	18	A
$I_C @ T_C = 100^\circ C$	Continuous Collector Current	9.0	
$I_{CM}$	Pulse Collector Current, $V_{GE} = 15V$	27	
$I_{LM}$	Clamped Inductive Load Current, $V_{GE} = 20V$ ①	36	
$I_F @ T_C = 25^\circ C$	Diode Continuous Forward Current	18	
$I_F @ T_C = 100^\circ C$	Diode Continuous Forward Current	9.0	
$I_{FM}$	Diode Maximum Forward Current ②	36	
$V_{GE}$	Continuous Gate-to-Emitter Voltage	$\pm 20$	V
	Transient Gate-to-Emitter Voltage	$\pm 30$	
$P_D @ T_C = 25^\circ C$	Maximum Power Dissipation	34	W
	$P_D @ T_C = 100^\circ C$	Maximum Power Dissipation	
$T_J$ $T_{STG}$	Operating Junction and Storage Temperature Range	-55 to +150	$^\circ C$
	Soldering Temperature, for 10 sec.	300 (0.063 in. (1.6mm) from case)	
	Mounting Torque, 6-32 or M3 Screw	10 lbf-in (1.1 N·m)	

### Thermal Resistance

	Parameter	Min.	Typ.	Max.	Units
$R_{\theta JC}$ (IGBT)	Thermal Resistance Junction-to-Case-(each IGBT)	—	—	3.7	$^\circ C/W$
$R_{\theta JC}$ (Diode)	Thermal Resistance Junction-to-Case-(each Diode)	—	—	6.6	
$R_{\theta CS}$	Thermal Resistance, Case-to-Sink (flat, greased surface)	—	0.50	—	
$R_{\theta JA}$	Thermal Resistance, Junction-to-Ambient (typical socket mount)	—	—	65	

**Electrical Characteristics @  $T_J = 25^\circ\text{C}$  (unless otherwise specified)**

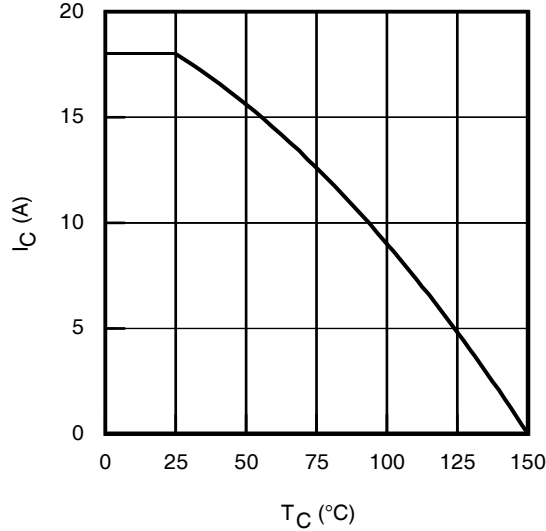
	Parameter	Min.	Typ.	Max.	Units	Conditions	Ref.Fig
$V_{(BR)CES}$	Collector-to-Emitter Breakdown Voltage	600	—	—	V	$V_{GE} = 0V, I_C = 100\mu\text{A}$ ②	CT6
$\Delta V_{(BR)CES}/\Delta T_J$	Temperature Coeff. of Breakdown Voltage	—	0.66	—	V/ $^\circ\text{C}$	$V_{GE} = 0V, I_C = 1.0\text{mA}$ (-55 $^\circ\text{C}$ -150 $^\circ\text{C}$ )	CT6
$V_{CE(on)}$	Collector-to-Emitter Saturation Voltage	—	1.44	1.65	V	$I_C = 9.0A, V_{GE} = 15V, T_J = 25^\circ\text{C}$	5,6,7
		—	1.69	—		$I_C = 9.0A, V_{GE} = 15V, T_J = 125^\circ\text{C}$	9,10,11
		—	1.72	—		$I_C = 9.0A, V_{GE} = 15V, T_J = 150^\circ\text{C}$	
$V_{GE(th)}$	Gate Threshold Voltage	4.0	—	6.5	V	$V_{CE} = V_{GE}, I_C = 350\mu\text{A}$	9, 10,
$\Delta V_{GE(th)}/\Delta T_J$	Threshold Voltage temp. coefficient	—	-13	—	mV/ $^\circ\text{C}$	$V_{CE} = V_{GE}, I_C = 1.0\text{mA}$ (-55 $^\circ\text{C}$ - 150 $^\circ\text{C}$ )	11, 12
$g_{fe}$	Forward Transconductance	—	7.1	—	S	$V_{CE} = 50V, I_C = 9.0A$	
$I_{CES}$	Collector-to-Emitter Leakage Current	—	—	20	$\mu\text{A}$	$V_{GE} = 0V, V_{CE} = 600V$	
		—	60	—		$V_{GE} = 0V, V_{CE} = 600V, T_J = 150^\circ\text{C}$	
$V_{FM}$	Diode Forward Voltage Drop	—	2.3	3.0	V	$I_F = 9.0A$	8
		—	1.7	—		$I_F = 9.0A, T_J = 150^\circ\text{C}$	
$I_{GES}$	Gate-to-Emitter Leakage Current	—	—	$\pm 100$	nA	$V_{GE} = \pm 20V$	

**Switching Characteristics @  $T_J = 25^\circ\text{C}$  (unless otherwise specified)**

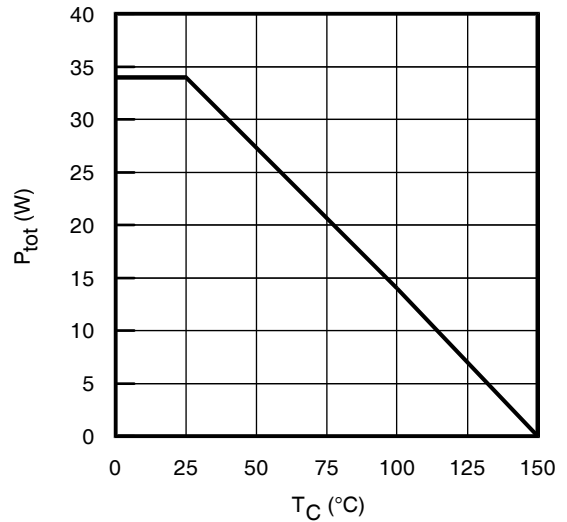
	Parameter	Min.	Typ.	Max.	Units	Conditions	Ref.Fig
$Q_g$	Total Gate Charge (turn-on)	—	25	38	nC	$I_C = 9.0A$ $V_{GE} = 15V$ $V_{CC} = 400V$	24
$Q_{ge}$	Gate-to-Emitter Charge (turn-on)	—	6.6	9.9			CT1
$Q_{gc}$	Gate-to-Collector Charge (turn-on)	—	9.5	14			
$E_{on}$	Turn-On Switching Loss	—	59	143	$\mu\text{J}$	$I_C = 9.0A, V_{CC} = 400V, V_{GE} = 15V$ $R_G = 22\Omega, L = 1.0\text{mH}, T_J = 25^\circ\text{C}$ Energy losses include tail & diode reverse recovery	CT4
$E_{off}$	Turn-Off Switching Loss	—	177	264			
$E_{total}$	Total Switching Loss	—	236	407			
$t_{d(on)}$	Turn-On delay time	—	34	52	ns	$I_C = 9.0A, V_{CC} = 400V, V_{GE} = 15V$ $R_G = 22\Omega, L = 1.0\text{mH}, T_J = 25^\circ\text{C}$	CT4
$t_r$	Rise time	—	12	29			
$t_{d(off)}$	Turn-Off delay time	—	84	103			
$t_f$	Fall time	—	24	42			
$E_{on}$	Turn-On Switching Loss	—	131	—			$\mu\text{J}$
$E_{off}$	Turn-Off Switching Loss	—	276	—	CT4		
$E_{total}$	Total Switching Loss	—	407	—	WF1, WF2		
$t_{d(on)}$	Turn-On delay time	—	31	—	ns	$I_C = 9.0A, V_{CC} = 400V, V_{GE} = 15V$ $R_G = 22\Omega, L = 1.0\text{mH}$ $T_J = 150^\circ\text{C}$	14, 16
$t_r$	Rise time	—	15	—			CT4
$t_{d(off)}$	Turn-Off delay time	—	104	—			WF1
$t_f$	Fall time	—	86	—			WF2
$C_{ies}$	Input Capacitance	—	769	—			pF
$C_{oes}$	Output Capacitance	—	59	—			
$C_{res}$	Reverse Transfer Capacitance	—	21	—			
RBSOA	Reverse Bias Safe Operating Area	FULL SQUARE				$T_J = 150^\circ\text{C}, I_C = 36A$ $V_{CC} = 480V, V_p = 600V$ $R_G = 22\Omega, V_{GE} = +20V \text{ to } 0V$	4 CT2
SCSOA	Short Circuit Safe Operating Area	5	—	—	$\mu\text{s}$	$V_{CC} = 400V, V_p = 600V$ $R_G = 75\Omega, V_{GE} = +15V \text{ to } 0V$	22, CT3 WF4
$E_{rec}$	Reverse Recovery Energy of the Diode	—	176	—	$\mu\text{J}$	$T_J = 150^\circ\text{C}$	17, 18, 19
$t_{rr}$	Diode Reverse Recovery Time	—	72	—	ns	$V_{CC} = 400V, I_F = 9.0A$	20, 21
$I_{rr}$	Peak Reverse Recovery Current	—	19	—	A	$V_{GE} = 15V, R_G = 22\Omega, L = 1.0\text{mH}$	WF3

**Notes:**

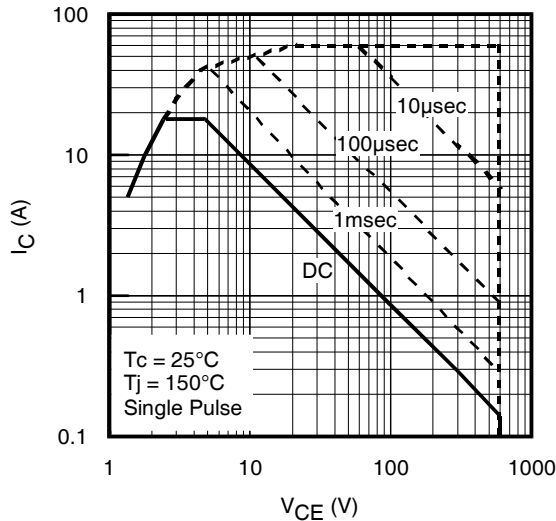
- ①  $V_{CC} = 80\% (V_{CES}), V_{GE} = 20V, L = 80\mu\text{H}, R_G = 22\Omega$ .
- ② Pulse width limited by max. junction temperature.
- ③ Refer to AN-1086 for guidelines for measuring  $V_{(BR)CES}$  safely.



**Fig. 1 - Maximum DC Collector Current vs. Case Temperature**

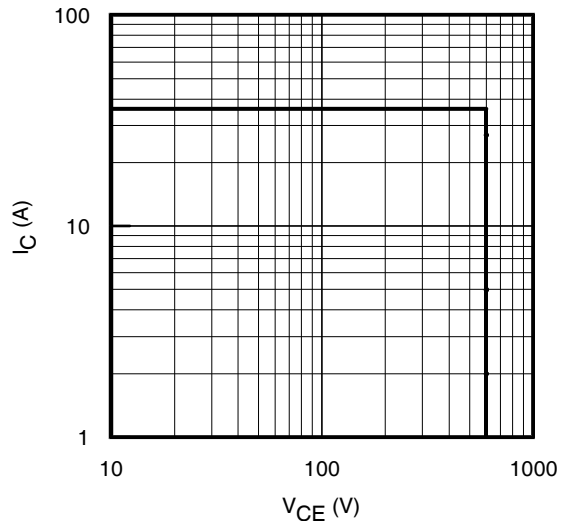


**Fig. 2 - Power Dissipation vs. Case Temperature**



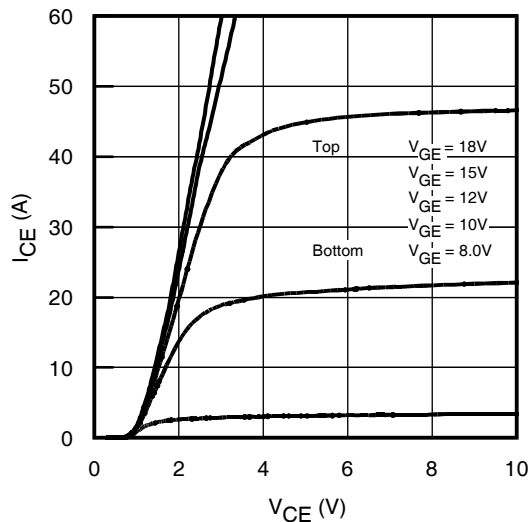
**Fig. 3 - Forward SOA**

$T_C = 25^\circ\text{C}$ ,  $T_J \leq 150^\circ\text{C}$ ;  $V_{GE} = 15\text{V}$

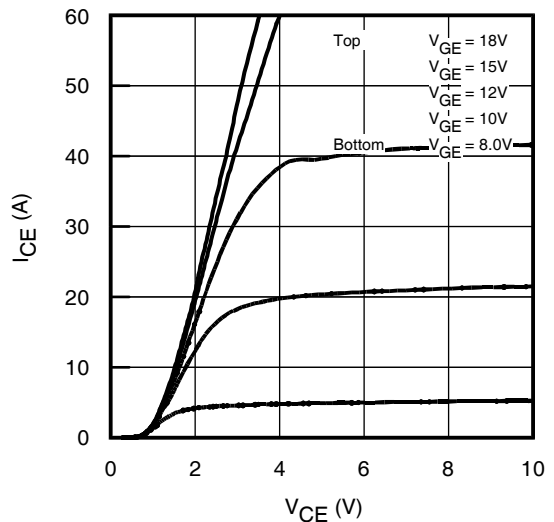


**Fig. 4 - Reverse Bias SOA**

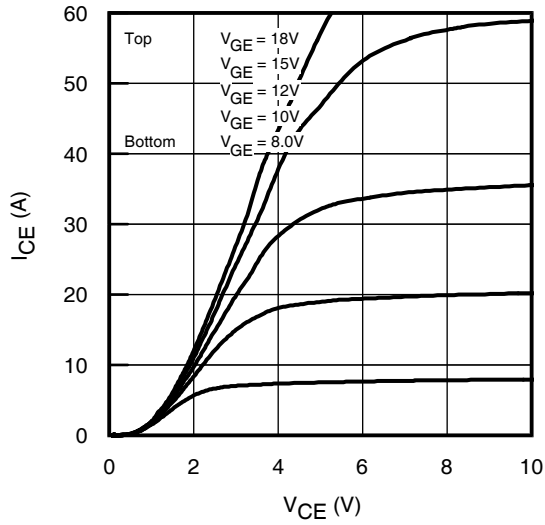
$T_J = 150^\circ\text{C}$ ;  $V_{GE} = 20\text{V}$



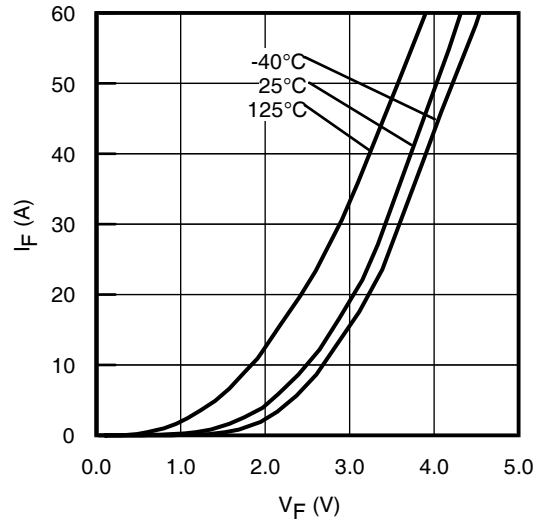
**Fig. 5 - Typ. IGBT Output Characteristics**  
 $T_J = -40^\circ\text{C}$ ;  $t_p = 80\mu\text{s}$



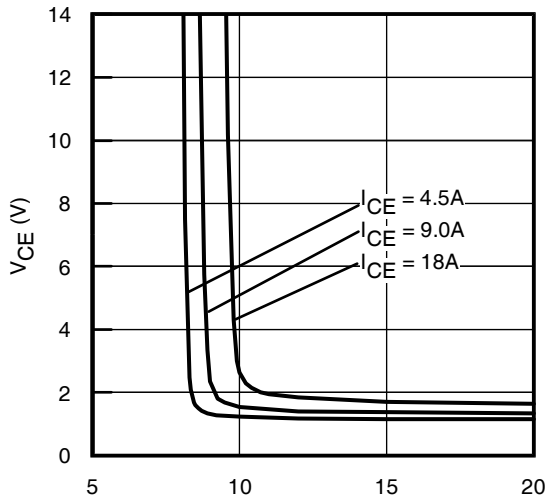
**Fig. 6 - Typ. IGBT Output Characteristics**  
 $T_J = 25^\circ\text{C}$ ;  $t_p = 80\mu\text{s}$



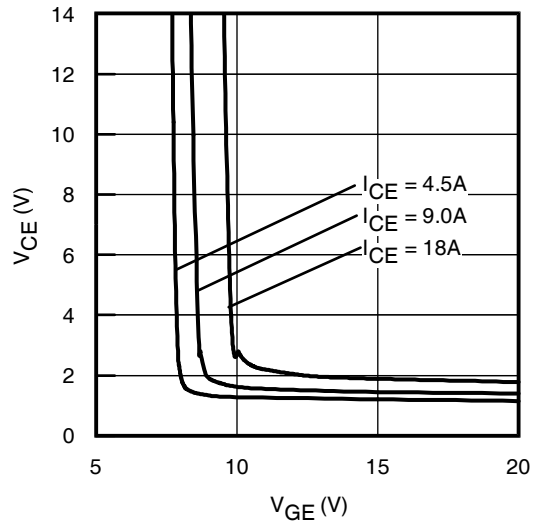
**Fig. 7** - Typ. IGBT Output Characteristics  
 $T_J = 150^\circ\text{C}$ ;  $t_p = 80\mu\text{s}$



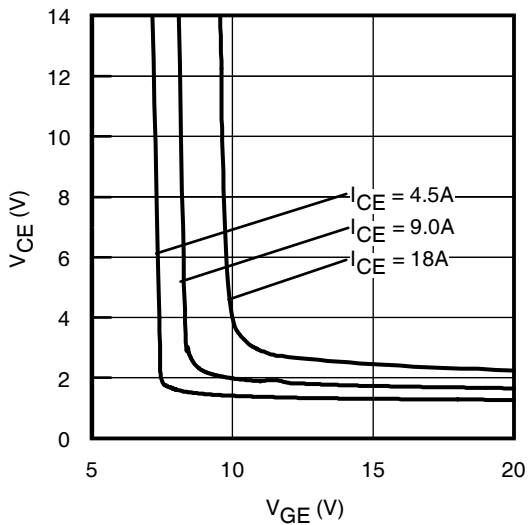
**Fig. 8** - Typ. Diode Forward Characteristics  
 $t_p = 80\mu\text{s}$



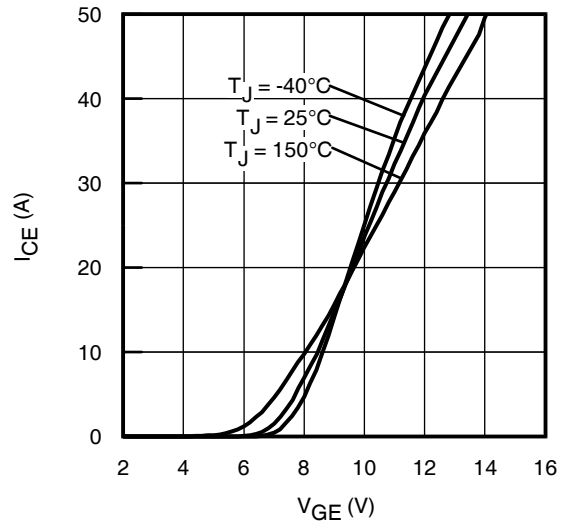
**Fig. 9** - Typical  $V_{CE}$  vs.  $V_{GE}$   
 $T_J = -40^\circ\text{C}$



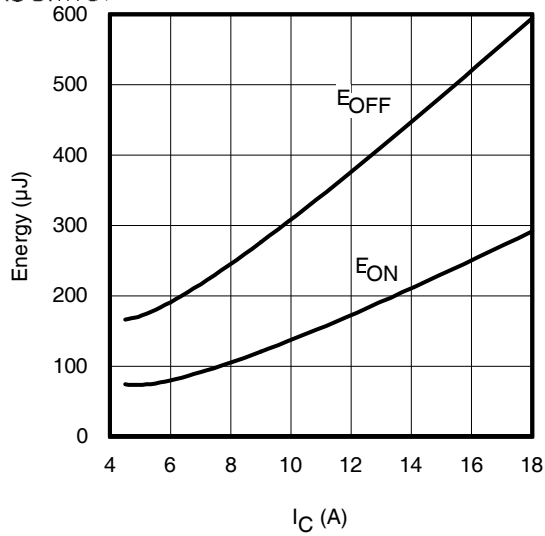
**Fig. 10** - Typical  $V_{CE}$  vs.  $V_{GE}$   
 $T_J = 25^\circ\text{C}$



**Fig. 11** - Typical  $V_{CE}$  vs.  $V_{GE}$   
 $T_J = 150^\circ\text{C}$

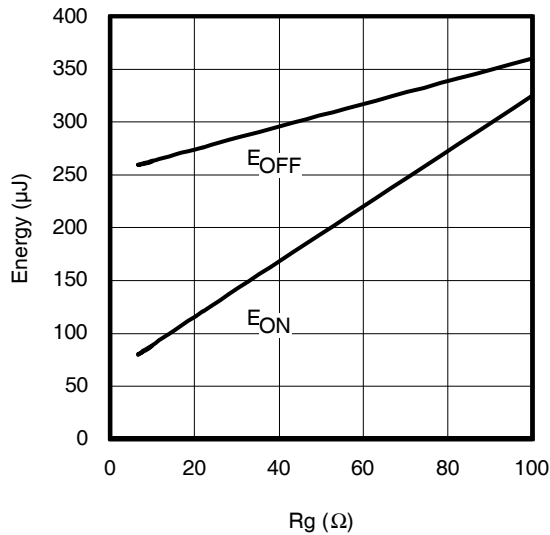


**Fig. 12** - Typ. Transfer Characteristics  
 $V_{CE} = 50\text{V}$ ;  $t_p = 10\mu\text{s}$



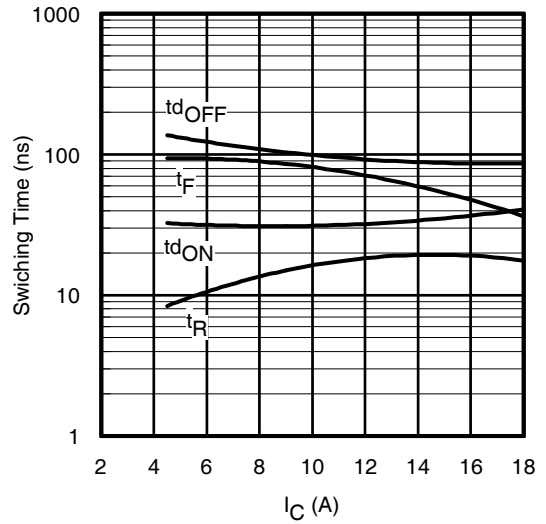
**Fig. 13** - Typ. Energy Loss vs.  $I_C$

$T_J = 150^\circ\text{C}$ ;  $L = 1.0\text{mH}$ ;  $V_{CE} = 400\text{V}$ ,  $R_G = 22\Omega$ ;  $V_{GE} = 15\text{V}$



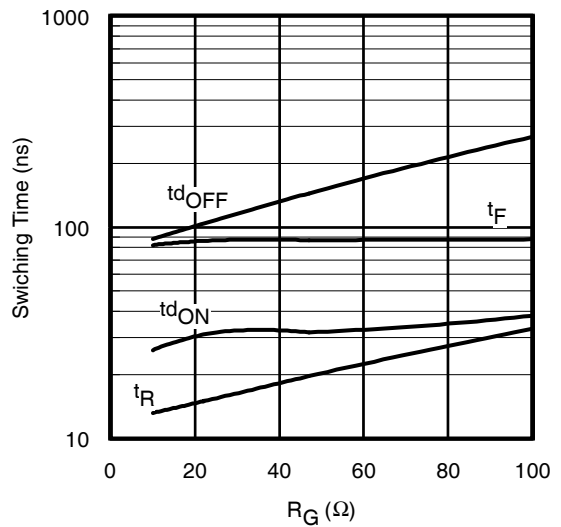
**Fig. 15** - Typ. Energy Loss vs.  $R_G$

$T_J = 150^\circ\text{C}$ ;  $L = 1.0\text{mH}$ ;  $V_{CE} = 400\text{V}$ ,  $I_{CE} = 9.0\text{A}$ ;  $V_{GE} = 15\text{V}$



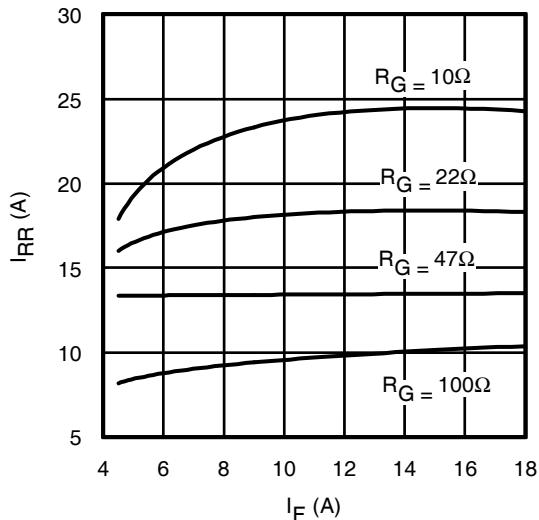
**Fig. 14** - Typ. Switching Time vs.  $I_C$

$T_J = 150^\circ\text{C}$ ;  $L = 1.0\text{mH}$ ;  $V_{CE} = 400\text{V}$ ,  $R_G = 22\Omega$ ;  $V_{GE} = 15\text{V}$



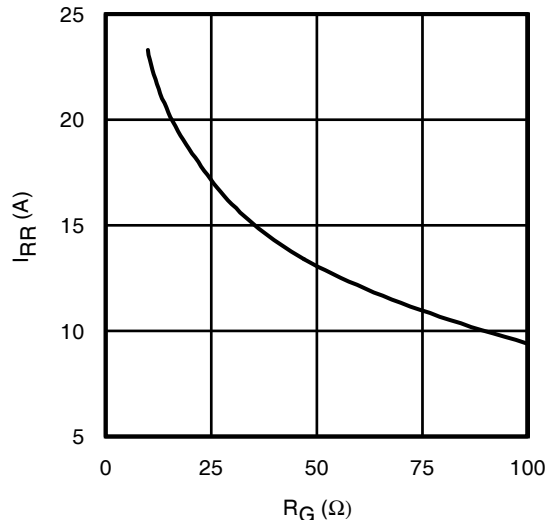
**Fig. 16** - Typ. Switching Time vs.  $R_G$

$T_J = 150^\circ\text{C}$ ;  $L = 1.0\text{mH}$ ;  $V_{CE} = 400\text{V}$ ,  $I_{CE} = 9.0\text{A}$ ;  $V_{GE} = 15\text{V}$



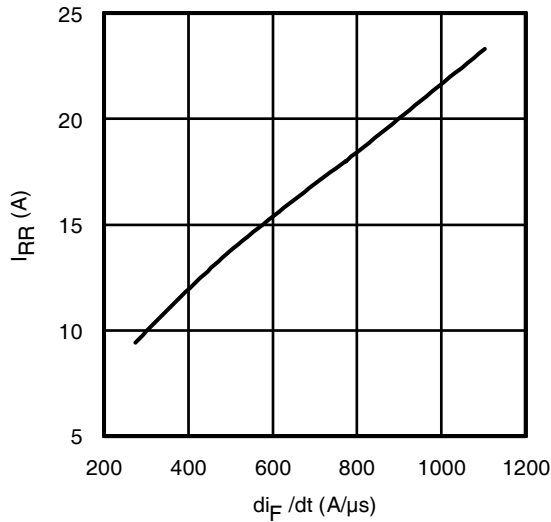
**Fig. 17** - Typ. Diode  $I_{RR}$  vs.  $I_F$

$T_J = 150^\circ\text{C}$

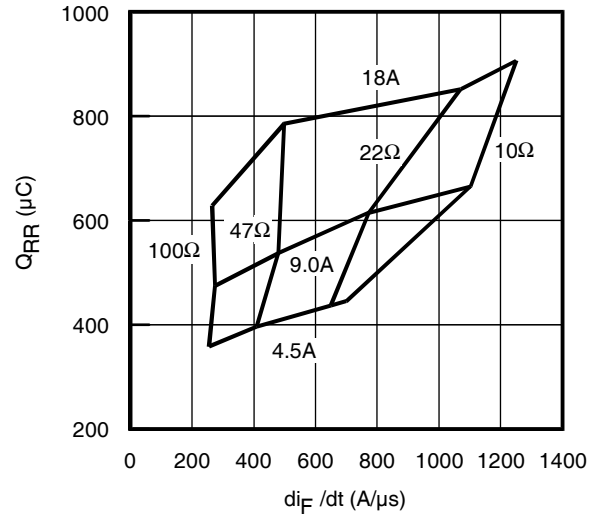


**Fig. 18** - Typ. Diode  $I_{RR}$  vs.  $R_G$

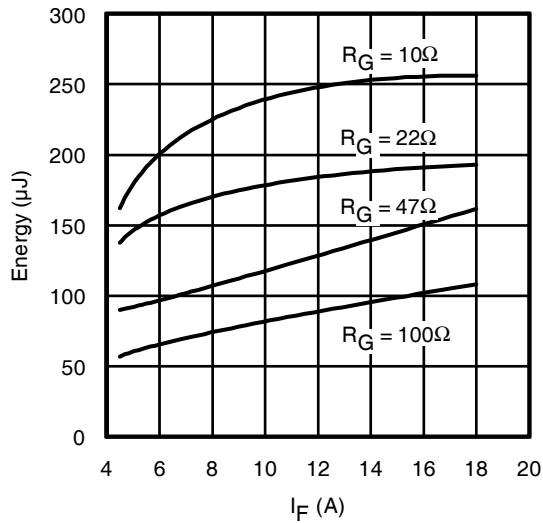
$T_J = 150^\circ\text{C}$



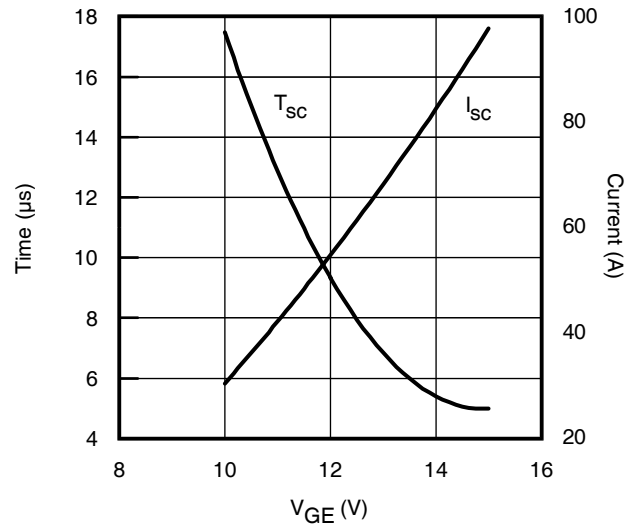
**Fig. 19** - Typ. Diode  $I_{RR}$  vs.  $di_F/dt$   
 $V_{CC} = 400V$ ;  $V_{GE} = 15V$ ;  $I_F = 9.0A$ ;  $T_J = 150^\circ C$



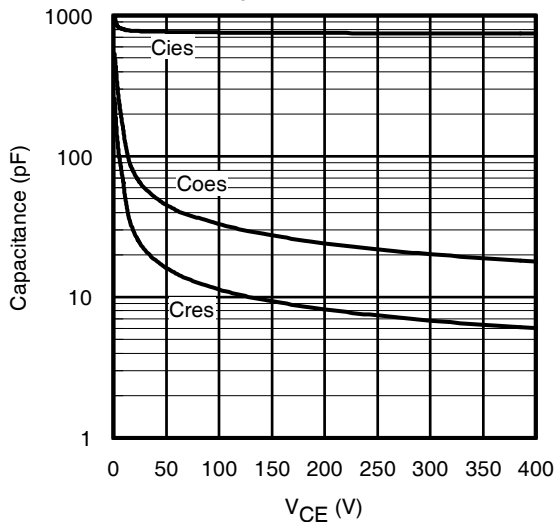
**Fig. 20** - Typ. Diode  $Q_{RR}$  vs.  $di_F/dt$   
 $V_{CC} = 400V$ ;  $V_{GE} = 15V$ ;  $T_J = 150^\circ C$



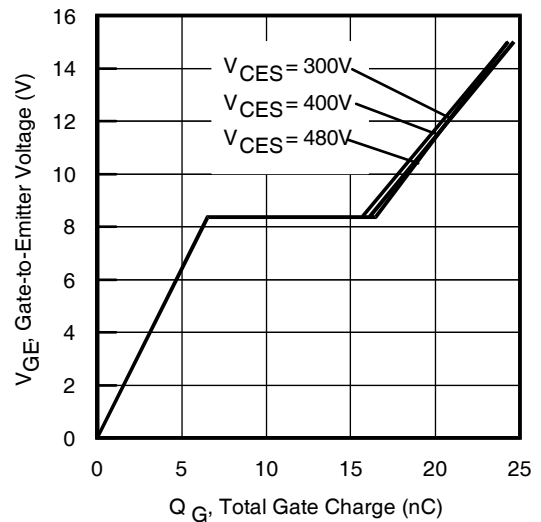
**Fig. 21** - Typ. Diode  $E_{RR}$  vs.  $I_F$   
 $T_J = 150^\circ C$



**Fig. 22** -  $V_{GE}$  vs. Short Circuit Time  
 $V_{CC} = 400V$ ;  $T_C = 25^\circ C$



**Fig. 23** - Typ. Capacitance vs.  $V_{CE}$   
 $V_{GE} = 0V$ ;  $f = 1MHz$



**Fig. 24** - Typical Gate Charge vs.  $V_{GE}$   
 $I_{CE} = 9.0A$ ;  $L = 1.0mH$

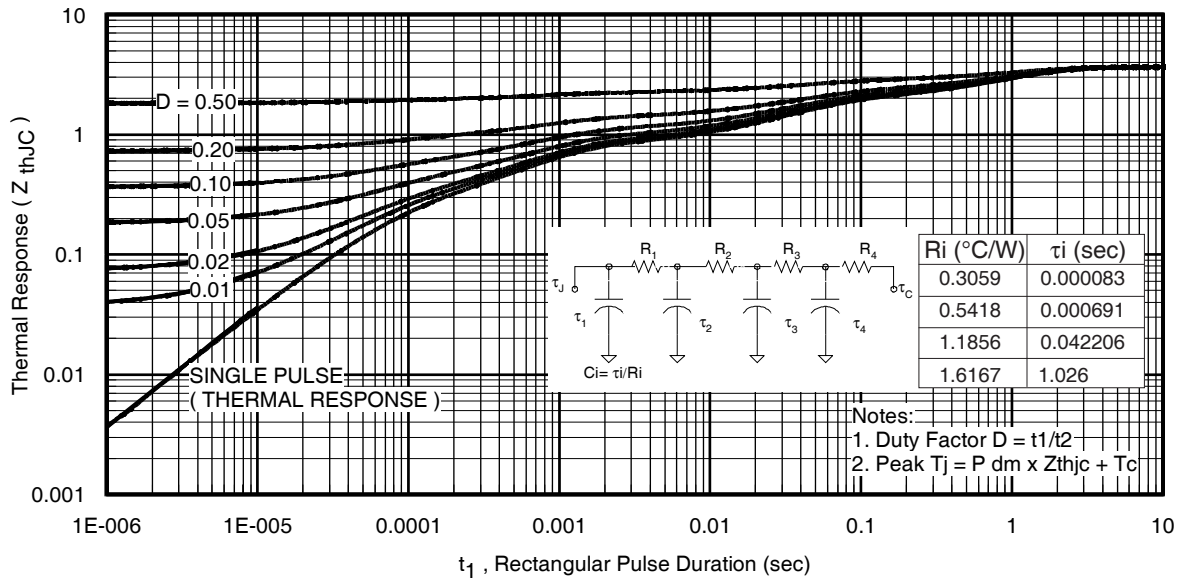


Fig 23. Maximum Transient Thermal Impedance, Junction-to-Case (IGBT)

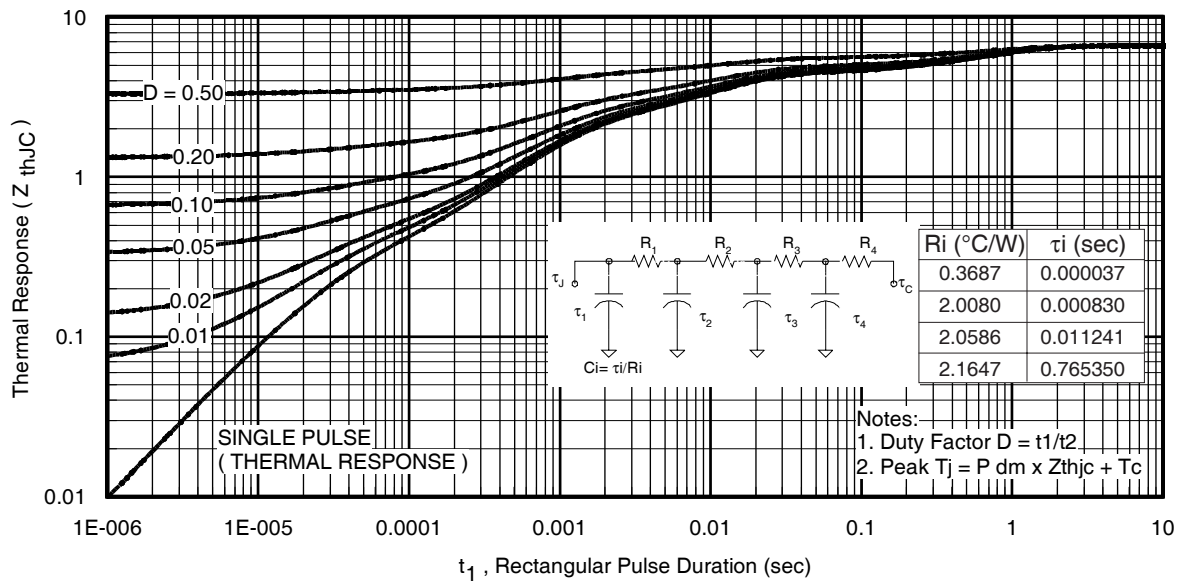
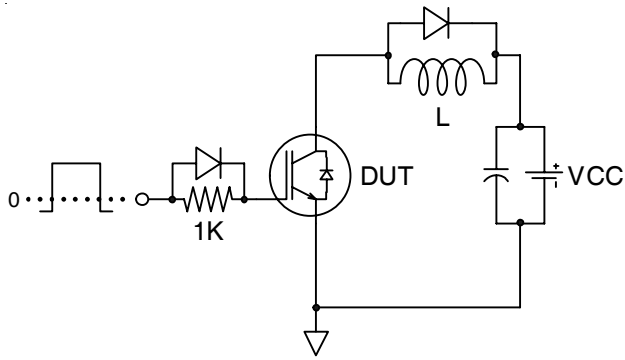
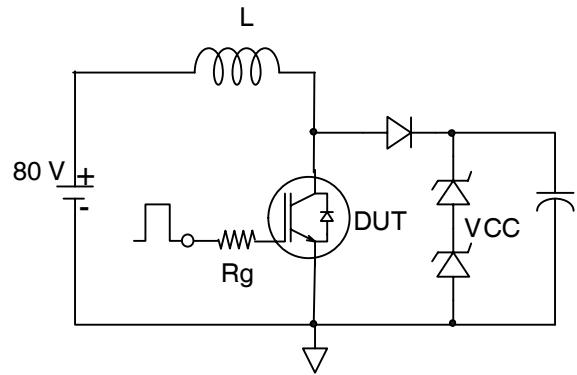


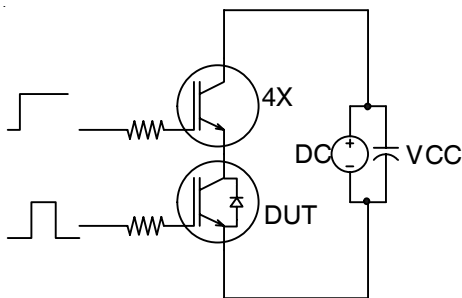
Fig. 24. Maximum Transient Thermal Impedance, Junction-to-Case (DIODE)



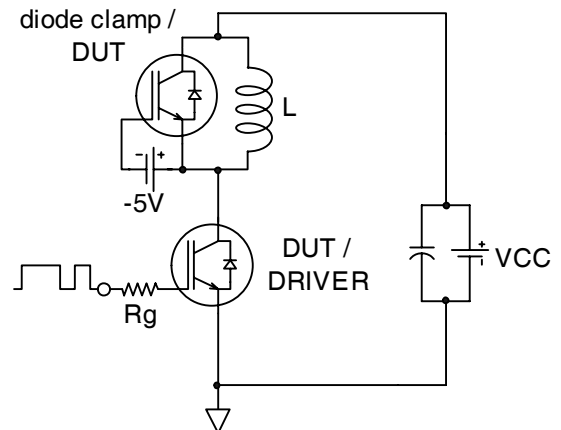
**Fig.C.T.1** - Gate Charge Circuit (turn-off)



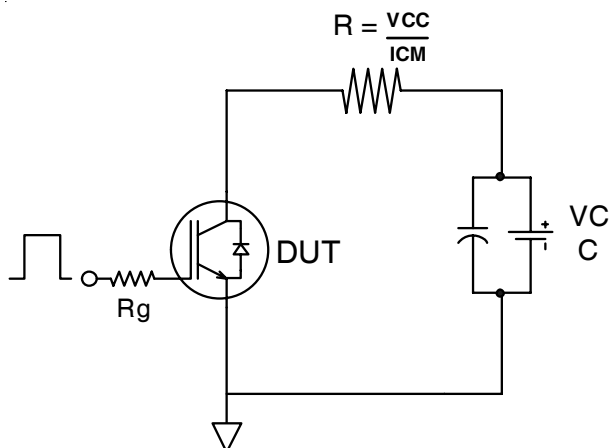
**Fig.C.T.2** - RBSOA Circuit



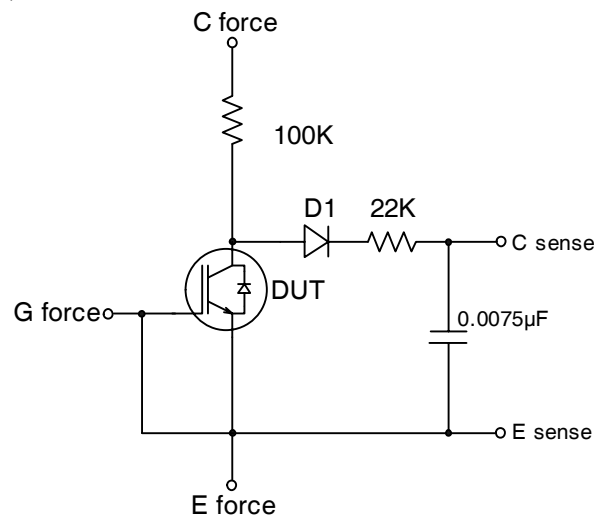
**Fig.C.T.3** - S.C. SOA Circuit



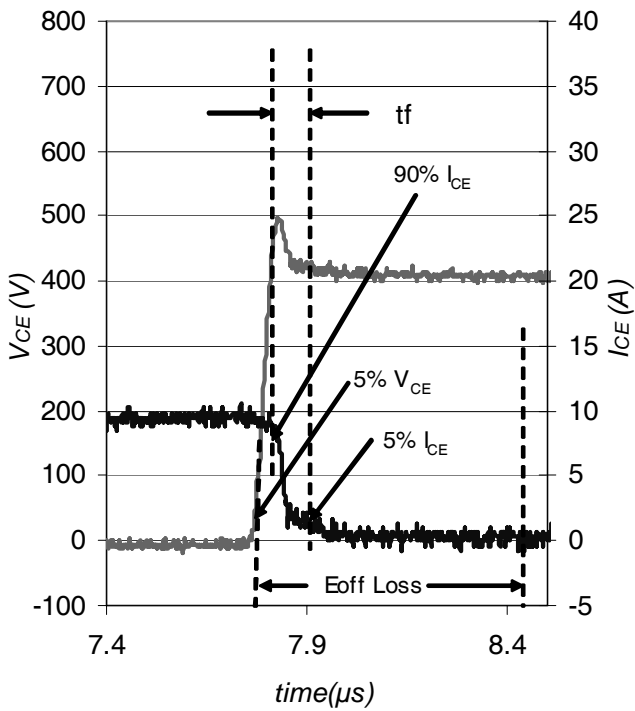
**Fig.C.T.4** - Switching Loss Circuit



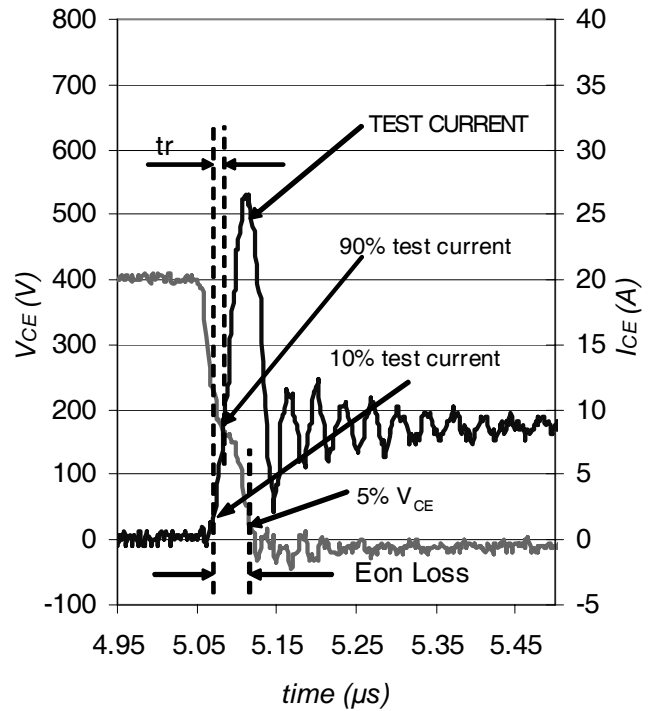
**Fig.C.T.5** - Resistive Load Circuit



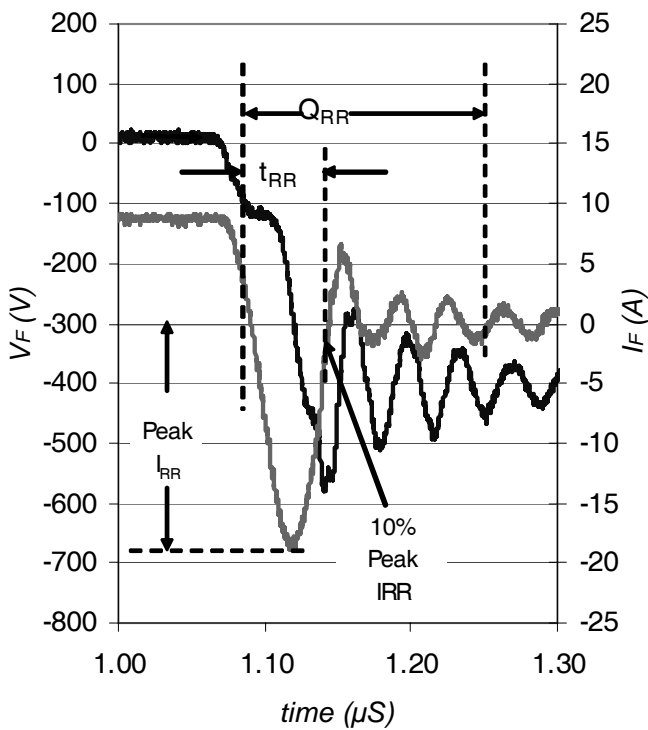
**Fig.C.T.6** - BVCES Filter Circuit



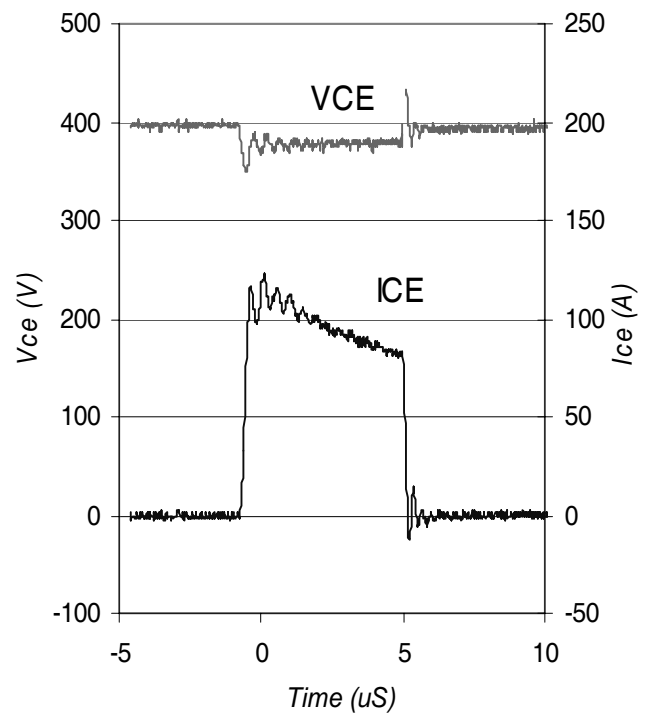
**Fig. WF1** - Typ. Turn-off Loss Waveform  
@  $T_J = 150^\circ\text{C}$  using Fig. CT.4



**Fig. WF2** - Typ. Turn-on Loss Waveform  
@  $T_J = 150^\circ\text{C}$  using Fig. CT.4



**Fig. WF3** - Typ. Diode Recovery Waveform  
@  $T_J = 150^\circ\text{C}$  using Fig. CT.4

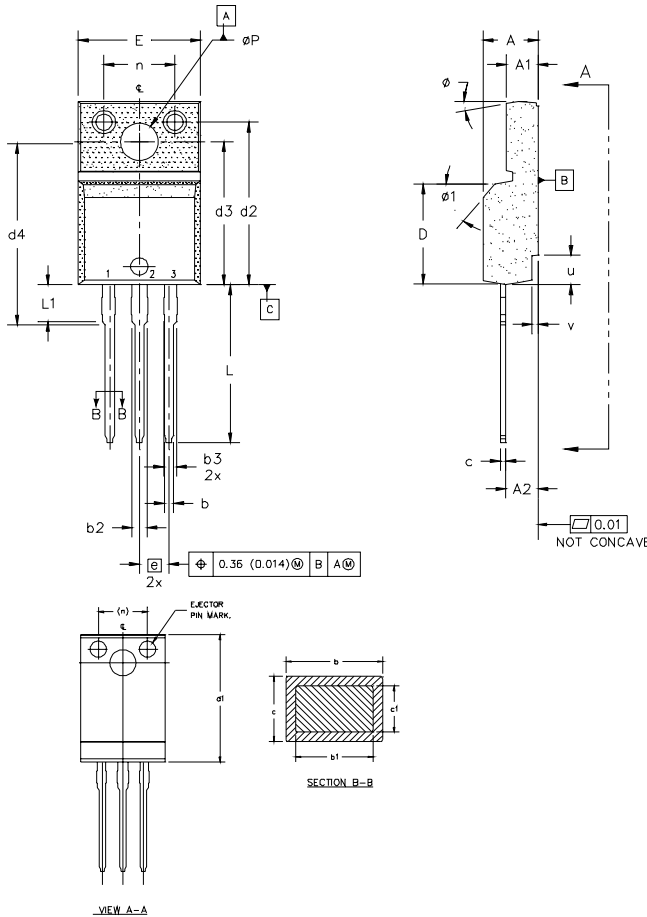


**Fig. WF4** - Typ. S.C. Waveform  
@  $T_J = 25^\circ\text{C}$  using Fig. CT.3

# IRGI4056DPbF

## TO-220 Full-Pak Package Outline

Dimensions are shown in millimeters (inches)



- NOTES:
- 1.0 DIMENSIONING AND TOLERANCING PER ASME Y14.5 M- 1994.
  - 2.0 DIMENSIONS ARE SHOWN IN MILLIMETERS [INCHES].
  - 3.0 LEAD DIMENSION AND FINISH UNCONTROLLED IN L1.
  - 4.0 DIMENSION D & E DO NOT INCLUDE MOLD FLASH. MOLD FLASH SHALL NOT EXCEED 0.005" (0.127) PER SIDE. THESE DIMENSIONS ARE MEASURED AT THE OUTERMOST EXTREMES OF THE PLASTIC BODY.
  - 5.0 DIMENSION b1 APPLY TO BASE METAL ONLY.
  - 6.0 STEP OPTIONAL ON PLASTIC BODY DEFINED BY DIMENSIONS u & v.
  - 7.0 CONTROLLING DIMENSION : INCHES.

SYMBOL	DIMENSIONS				NOTES
	MILLIMETERS		INCHES		
	MIN.	MAX.	MIN.	MAX.	
A	4.57	4.83	0.180	0.190	
A1	2.57	2.83	0.101	0.114	
A2	2.51	2.85	0.099	0.112	
b	0.622	0.89	0.024	0.035	
b1	0.622	0.838	0.024	0.033	5
b2	1.229	1.400	0.048	0.055	
b3	1.229	1.400	0.048	0.055	
c	0.440	0.629	0.017	0.025	
d	0.440	0.584	0.017	0.023	4
d1	8.65	9.80	0.341	0.386	
d2	15.80	16.12	0.622	0.635	
d3	13.97	14.22	0.550	0.560	
d4	12.30	12.92	0.484	0.509	
d5	8.64	9.91	0.340	0.390	
E	10.36	10.63	0.408	0.419	4
e	2.54 BSC		0.100 BSC		
L	13.20	13.73	0.520	0.541	
L1	3.10	3.50	0.122	0.138	3
n	6.05	6.15	0.238	0.242	
phi P	3.05	3.45	0.120	0.136	
u	2.40	2.50	0.094	0.098	6
v	0.40	0.50	0.016	0.020	6
phi	3"	7"	3"	7"	
phi 1		45'		45'	

**LEAD ASSIGNMENTS**

HEXFET

- 1.- GATE
- 2.- DRAIN
- 3.- SOURCE

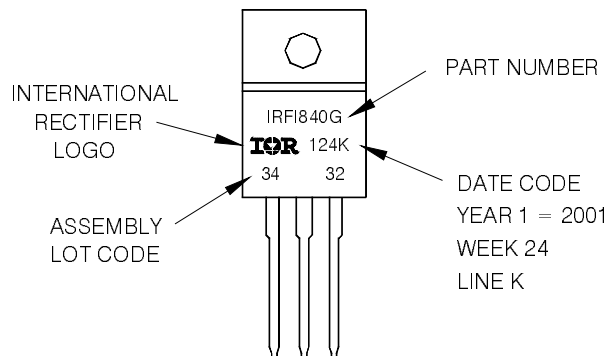
IGBTs, CoPACK

- 1.- GATE
- 2.- COLLECTOR
- 3.- EMITTER

## TO-220 Full-Pak Part Marking Information

EXAMPLE: THIS IS AN IRFI840G  
WITH ASSEMBLY  
LOT CODE 3432  
ASSEMBLED ON WW 24, 2001  
IN THE ASSEMBLY LINE "K"

Note: "P" in assembly line position  
indicates "Lead-Free"



**TO-220 Full-Pak package is not recommended for Surface Mount Application.**

Data and specifications subject to change without notice.  
This product has been designed and qualified for Industrial market.  
Qualification Standards can be found on IR's Web site.

## Looking for pricing, stock, or lifecycle information?

Click below to explore more details on WIN SOURCE:

- ⊖ [View IRGI4056 on WIN SOURCE](#)
- ⊖ [Infineon Technologies](#) Information

## Optimize Your Supply Chain with WIN SOURCE Solutions

- ✓ Global Sourcing Solution
- ✓ Obsolete Management
- ✓ Cost Control Management
- ✓ Shortage Management
- ✓ Alternative Solution
- ✓ Excess Inventory Management