



**THE DATASHEET OF
IRG7PSH73K10**



IRG7PSH73K10PbF

INSULATED GATE BIPOLAR TRANSISTOR

Features

- Low $V_{CE(ON)}$ Trench IGBT Technology
- Low Switching Losses
- Maximum Junction Temperature 175 °C
- 10 μ S short Circuit SOA
- Square RBSOA
- 100% of The Parts Tested for I_{LM}
- Positive $V_{CE(ON)}$ Temperature Coefficient
- Tight Parameter Distribution
- Lead Free Package

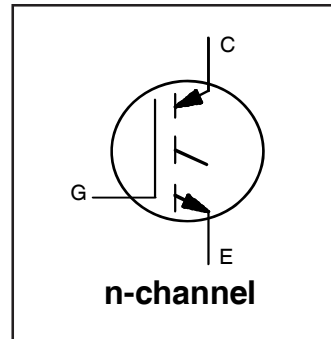

$V_{CES} = 1200V$
$I_{C(Nominal)} = 75A$
$t_{SC} \geq 10\mu s, T_{J(max)} = 175^{\circ}C$
$V_{CE(on)} \text{ typ.} = 2.0V$

Benefits

- High Efficiency in a Wide Range of Applications
- Suitable for a Wide Range of Switching Frequencies due to Low $V_{CE(ON)}$ and Low Switching Losses
- Rugged Transient Performance for Increased Reliability
- Excellent Current Sharing in Parallel Operation

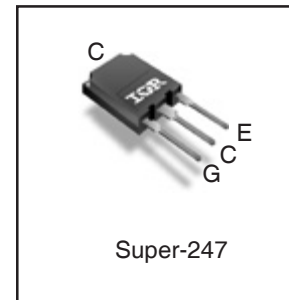

G	C	E
Gate	Collector	Emitter

Absolute Maximum Ratings

	Parameter	Max.	Units
V_{CES}	Collector-to-Emitter Voltage	1200	V
$I_C @ T_C = 25^{\circ}C$	Continuous Collector Current	220 [Ⓞ]	A
$I_C @ T_C = 100^{\circ}C$	Continuous Collector Current	130	
$I_{NOMINAL}$	Nominal Current	75	
I_{CM}	Pulse Collector Current, $V_{GE}=15V$	225	
I_{LM}	Clamped Inductive Load Current, $V_{GE}=20V$ [Ⓢ]	300	
V_{GE}	Continuous Gate-to-Emitter Voltage	± 30	V
$P_D @ T_C = 25^{\circ}C$	Maximum Power Dissipation	1150	W
$P_D @ T_C = 100^{\circ}C$	Maximum Power Dissipation	580	
T_J T_{STG}	Operating Junction and Storage Temperature Range	-55 to +175	$^{\circ}C$
	Soldering Temperature, for 10 sec.	300 (0.063 in. (1.6mm) from case)	
	Mounting Torque, 6-32 or M3 Screw	10 lbf-in (1.1 N·m)	

Thermal Resistance

	Parameter	Min.	Typ.	Max.	Units
$R_{\theta JC}$ (IGBT)	Thermal Resistance Junction-to-Case-(each IGBT) [Ⓢ]	—	—	0.13	$^{\circ}C/W$
$R_{\theta CS}$	Thermal Resistance, Case-to-Sink (flat, greased surface) [Ⓢ]	—	0.24	—	
$R_{\theta JA}$	Thermal Resistance, Junction-to-Ambient (typical socket mount)	—	40	—	

Electrical Characteristics @ T_J = 25°C (unless otherwise specified)

	Parameter	Min.	Typ.	Max.	Units	Conditions
V _{(BR)CES}	Collector-to-Emitter Breakdown Voltage	1200	—	—	V	V _{GE} = 0V, I _C = 250μA ④
ΔV _{(BR)CES} /ΔT _J	Temperature Coeff. of Breakdown Voltage	—	1.58	—	V/°C	V _{GE} = 0V, I _C = 5.0mA (25°C-175°C) ④
V _{CE(on)}	Collector-to-Emitter Saturation Voltage	—	2.0	2.3	V	I _C = 75A, V _{GE} = 15V, T _J = 25°C ③
		—	2.50	—		I _C = 75A, V _{GE} = 15V, T _J = 150°C ③
		—	2.60	—		I _C = 75A, V _{GE} = 15V, T _J = 175°C ③
V _{GE(th)}	Gate Threshold Voltage	5.0	—	7.5	V	V _{CE} = V _{GE} , I _C = 3.5mA
ΔV _{GE(th)} /ΔT _J	Threshold Voltage temp. coefficient	—	-18	—	mV/°C	V _{CE} = V _{GE} , I _C = 3.5mA (25°C - 175°C)
g _{fe}	Forward Transconductance	—	53	—	S	V _{CE} = 50V, I _C = 75A, PW = 80μs
I _{CES}	Collector-to-Emitter Leakage Current	—	1.0	25	μA	V _{GE} = 0V, V _{CE} = 1200V, T _J = 25°C
		—	2340	—		V _{GE} = 0V, V _{CE} = 1200V, T _J = 175°C
I _{GES}	Gate-to-Emitter Leakage Current	—	—	±400	nA	V _{GE} = ±30V

Switching Characteristics @ T_J = 25°C (unless otherwise specified)

	Parameter	Min.	Typ.	Max.	Units	Conditions
Q _g	Total Gate Charge (turn-on)	—	360	540	nC	I _C = 75A ③
Q _{ge}	Gate-to-Emitter Charge (turn-on)	—	87	130		V _{GE} = 15V
Q _{gc}	Gate-to-Collector Charge (turn-on)	—	180	270		V _{CC} = 600V
E _{on}	Turn-On Switching Loss	—	7.7	8.7	mJ	I _C = 75A, V _{CC} = 600V, V _{GE} = 15V ③
E _{off}	Turn-Off Switching Loss	—	4.6	5.6		R _G = 4.7Ω, L = 200μH, T _J = 25°C
E _{total}	Total Switching Loss	—	12.3	14.3		Energy losses include tail & diode reverse recovery
t _{d(on)}	Turn-On delay time	—	63	81	ns	I _C = 75A, V _{CC} = 600V, V _{GE} = 15V ③
t _r	Rise time	—	118	138		R _G = 4.7Ω, L = 200μH, T _J = 25°C
t _{d(off)}	Turn-Off delay time	—	267	291		
t _f	Fall time	—	114	134		
E _{on}	Turn-On Switching Loss	—	11	—	mJ	I _C = 75A, V _{CC} = 600V, V _{GE} = 15V ③
E _{off}	Turn-Off Switching Loss	—	7.4	—		R _G = 4.7Ω, L = 200μH, T _J = 175°C
E _{total}	Total Switching Loss	—	18.4	—		Energy losses include tail & diode reverse recovery
t _{d(on)}	Turn-On delay time	—	62	—	ns	I _C = 75A, V _{CC} = 600V, V _{GE} = 15V ③
t _r	Rise time	—	110	—		R _G = 4.7Ω, L = 200μH
t _{d(off)}	Turn-Off delay time	—	330	—		T _J = 175°C
t _f	Fall time	—	237	—		
C _{ies}	Input Capacitance	—	9450	—	pF	V _{GE} = 0V
C _{oes}	Output Capacitance	—	340	—		V _{CC} = 30V
C _{res}	Reverse Transfer Capacitance	—	230	—		f = 1.0Mhz
RBSOA	Reverse Bias Safe Operating Area	FULL SQUARE				I _C = 300A V _{CC} = 960V, V _p = 1200V R _G = 4.7Ω, V _{GE} = +20V to 0V, T _J = 175°C
SCSOA	Short Circuit Safe Operating Area	10	—	—	μs	V _{CC} = 600V, V _p = 1200V, T _J = 150°C R _G = 4.7Ω, V _{GE} = +15V to 0V

Notes:

- ① Calculated continuous current based on maximum allowable junction temperature. Bond wire current limit is 195A. Note that current limitations arising from heating of the device leads may occur with some lead mounting arrangements. (Refer to AN-1140)
- ② V_{CC} = 80% (V_{CES}), V_{GE} = 20V, L = 20μH, R_G = 5.0Ω.
- ③ Pulse width ≤ 400μs; duty cycle ≤ 2%.
- ④ Refer to AN-1086 for guidelines for measuring V_{(BR)CES} safely.
- ⑤ R_θ is measured at T_J of approximately 90°C.

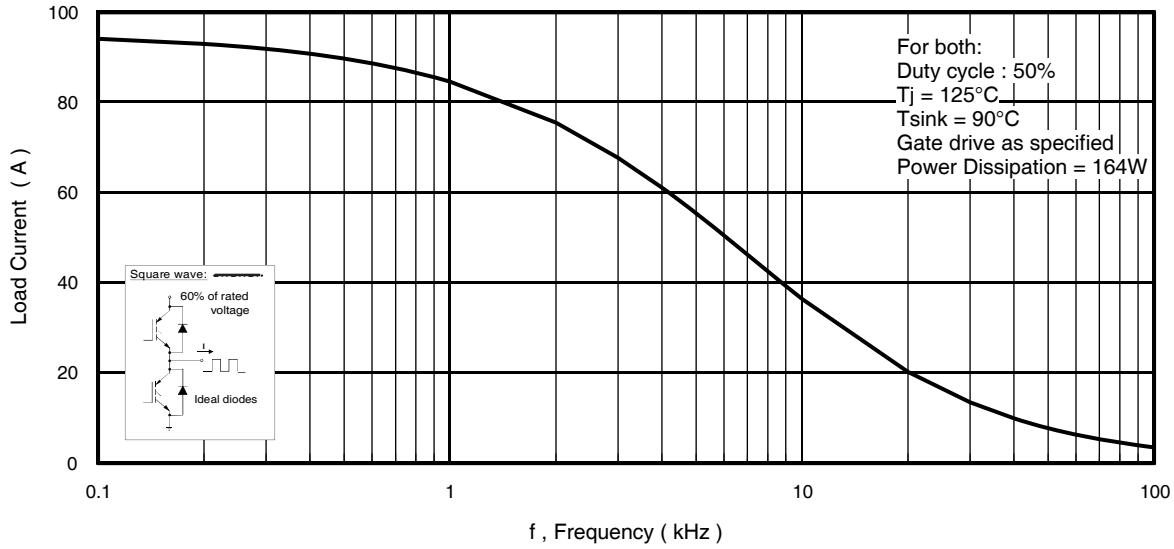

Fig. 1 - Typical Load Current vs. Frequency

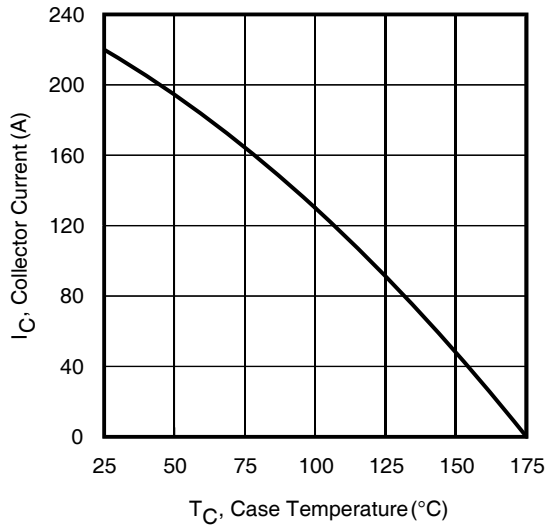

Fig. 2 - Maximum DC Collector Current vs. Case Temperature

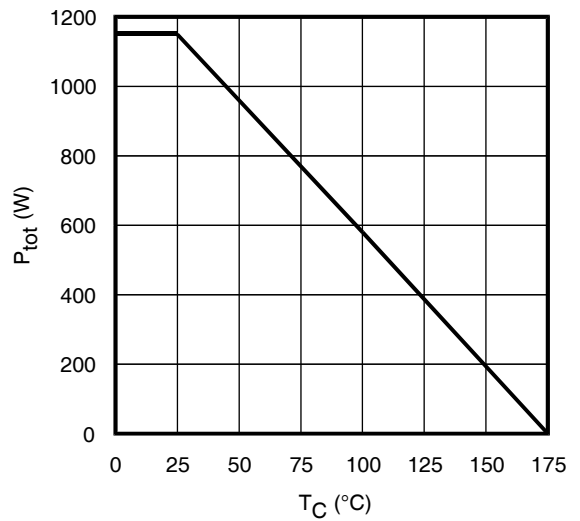

Fig. 3 - Power Dissipation vs. Case Temperature

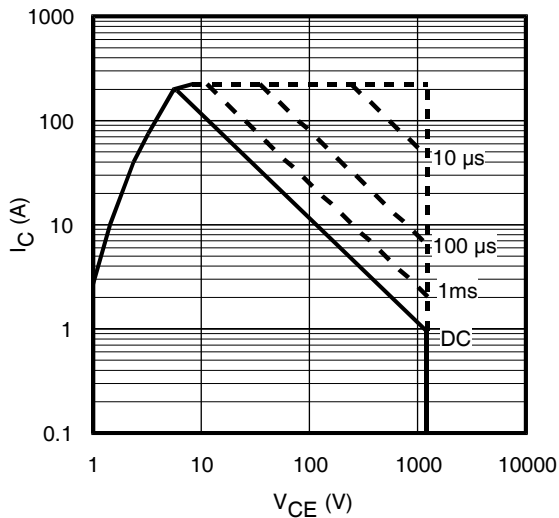

Fig. 4 - Forward SOA
 $T_C = 25^{\circ}\text{C}$, $T_J \leq 175^{\circ}\text{C}$; $V_{GE} = 15\text{V}$

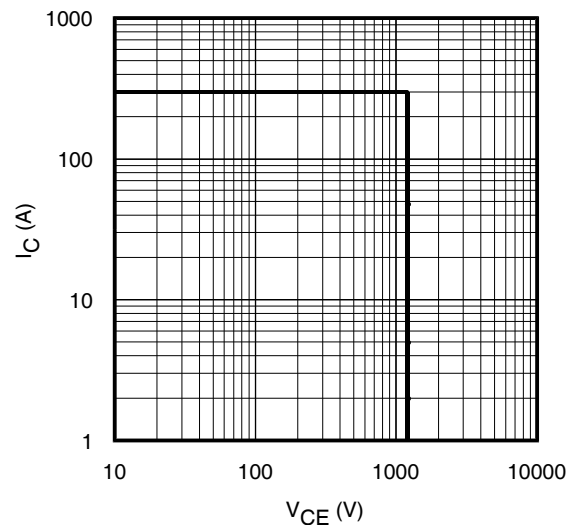

Fig. 5 - Reverse Bias SOA
 $T_J = 175^{\circ}\text{C}$; $V_{GE} = 20\text{V}$

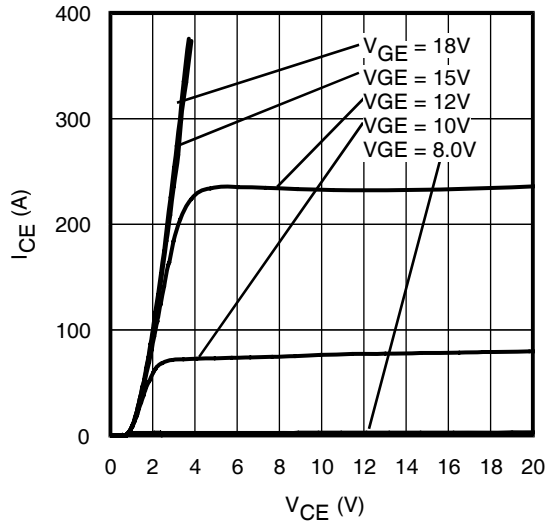

Fig. 6 - Typ. IGBT Output Characteristics
 $T_J = -40^\circ\text{C}$; $t_p = 80\mu\text{s}$

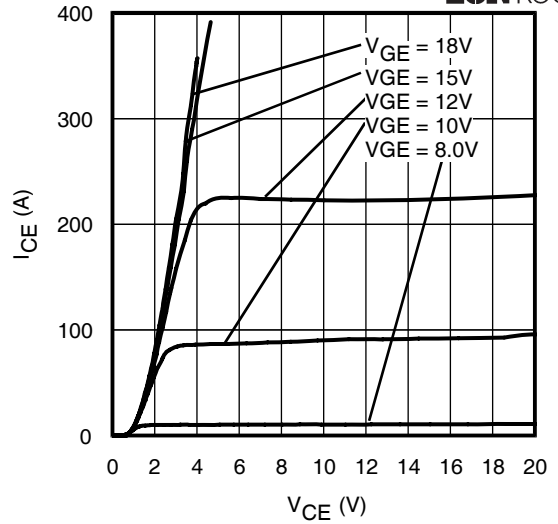

Fig. 7 - Typ. IGBT Output Characteristics
 $T_J = 25^\circ\text{C}$; $t_p = 80\mu\text{s}$

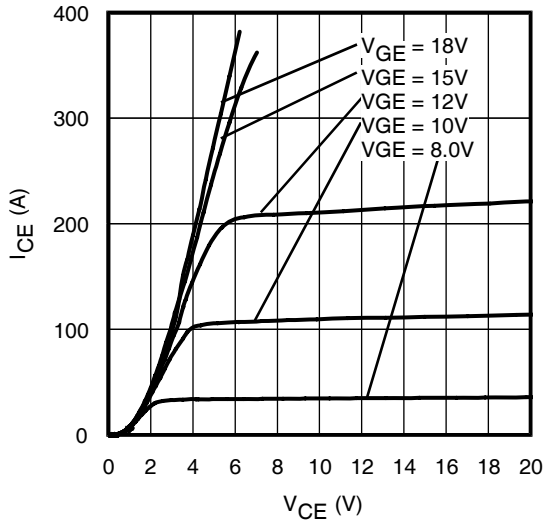

Fig. 8 - Typ. IGBT Output Characteristics
 $T_J = 175^\circ\text{C}$; $t_p = 80\mu\text{s}$

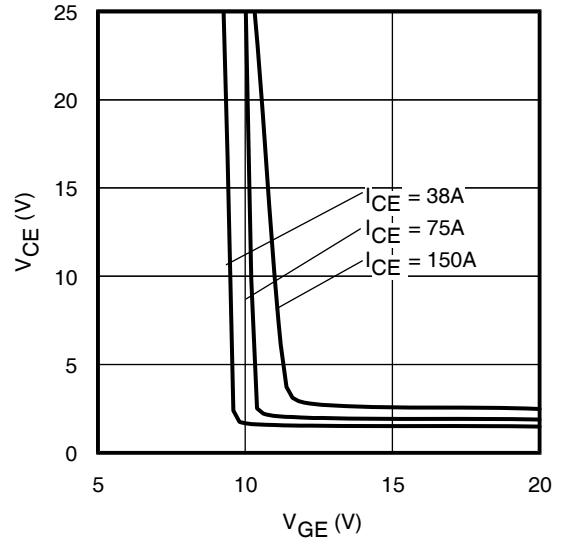

Fig. 9 - Typical V_{CE} vs. V_{GE}
 $T_J = -40^\circ\text{C}$

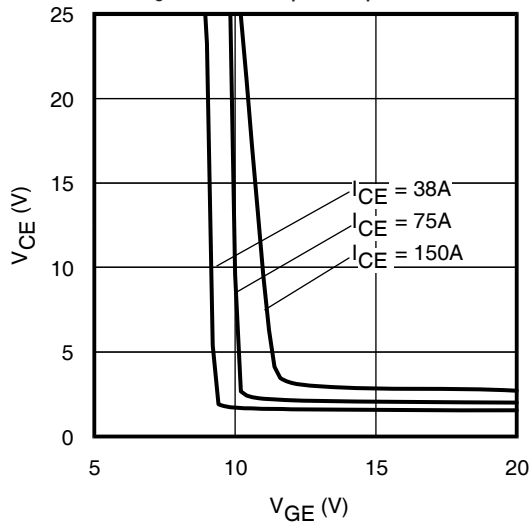

Fig. 10 - Typical V_{CE} vs. V_{GE}
 $T_J = 25^\circ\text{C}$

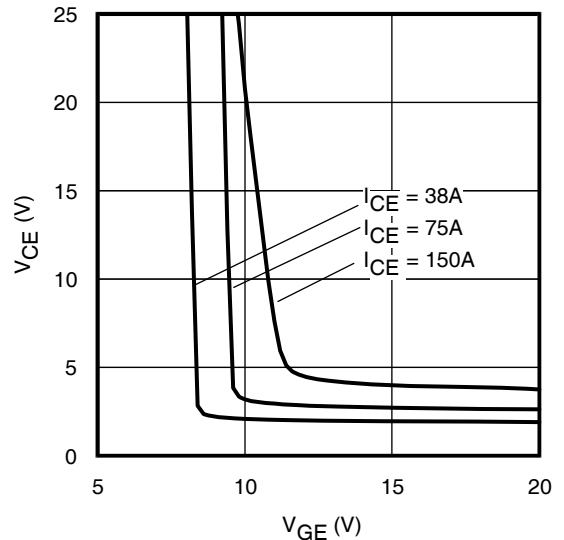

Fig. 11 - Typical V_{CE} vs. V_{GE}
 $T_J = 175^\circ\text{C}$

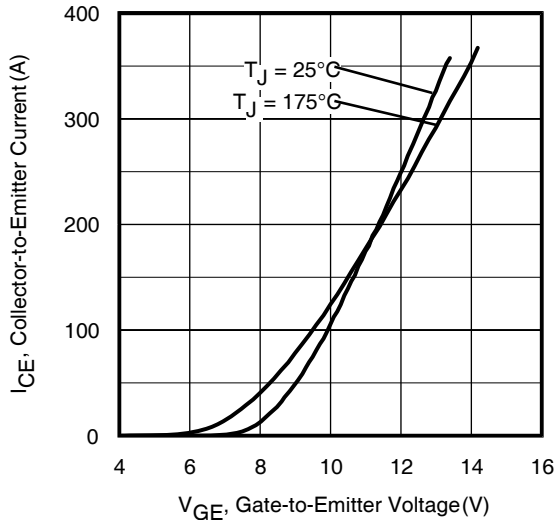

Fig. 12- Typ. Transfer Characteristics
 $V_{CE} = 50V$; $t_p = 10\mu s$

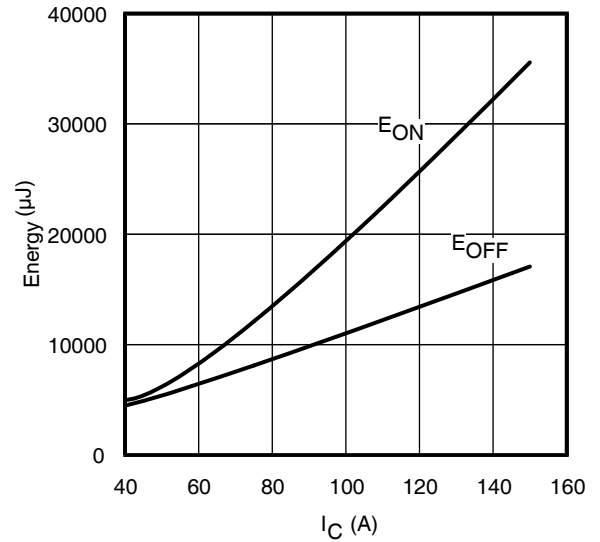

Fig. 13 - Typ. Energy Loss vs. I_C
 $T_J = 175^\circ C$; $L = 200\mu H$; $V_{CE} = 600V$, $R_G = 5.0\Omega$; $V_{GE} = 15V$

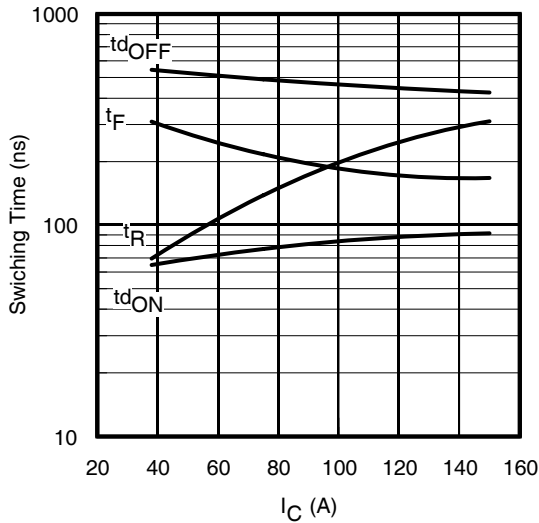

Fig. 14 - Typ. Switching Time vs. I_C
 $T_J = 175^\circ C$; $L = 200\mu H$; $V_{CE} = 600V$, $R_G = 5.0\Omega$; $V_{GE} = 15V$

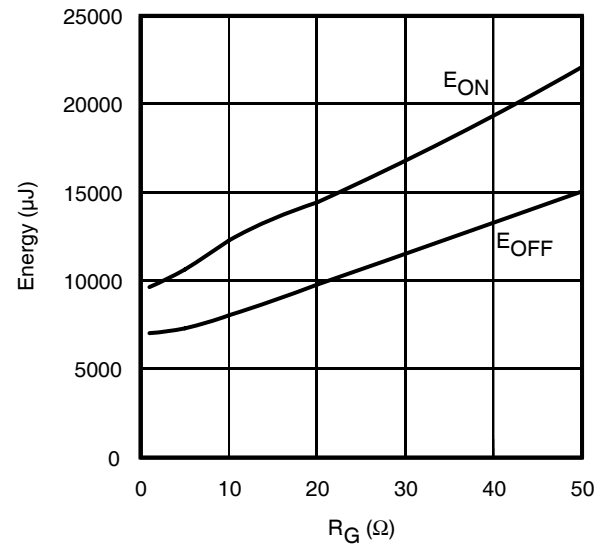

Fig. 15 - Typ. Energy Loss vs. R_G
 $T_J = 175^\circ C$; $L = 200\mu H$; $V_{CE} = 600V$, $I_{CE} = 75A$; $V_{GE} = 15V$

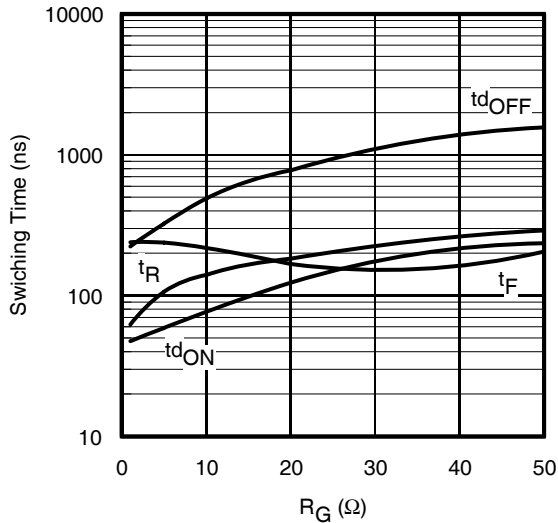

Fig. 16 - Typ. Switching Time vs. R_G
 $T_J = 175^\circ C$; $L = 200\mu H$; $V_{CE} = 600V$, $I_{CE} = 75A$; $V_{GE} = 15V$

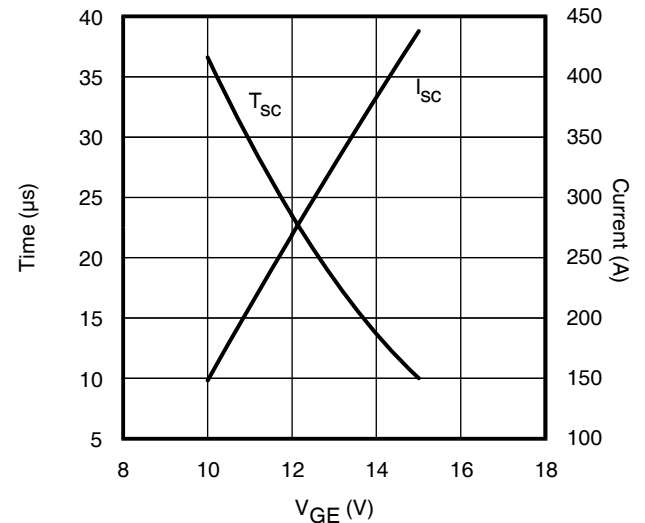

Fig. 17 - V_{GE} vs. Short Circuit Time
 $V_{CC} = 600V$; $T_C = 150^\circ C$

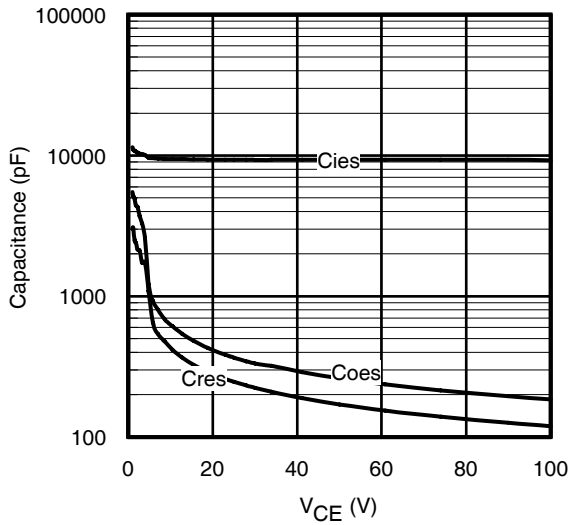

Fig. 18 - Typ. Capacitance vs. V_{CE}
 $V_{GE} = 0V$; $f = 1MHz$

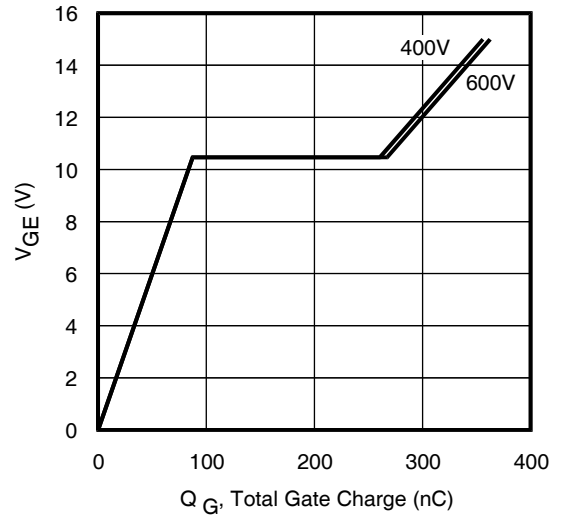

Fig. 19- Typical Gate Charge vs. V_{GE}
 $I_{CE} = 75A$; $L = 330\mu H$

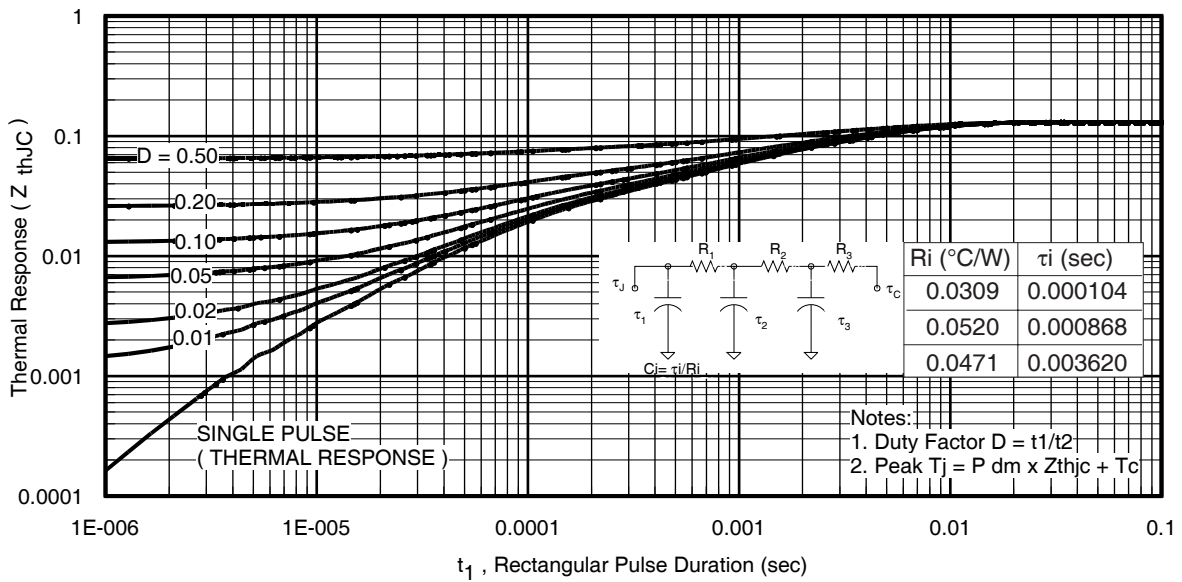

Fig 20. Maximum Transient Thermal Impedance, Junction-to-Case

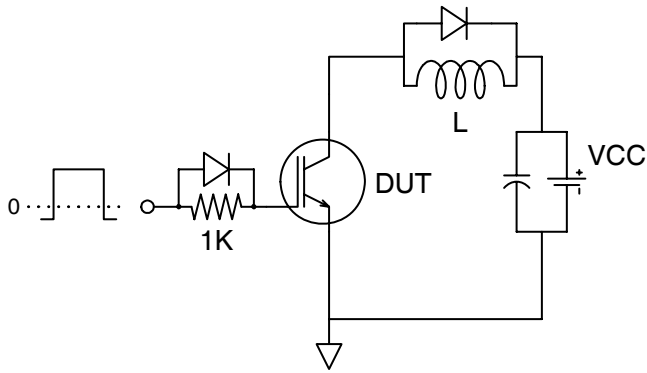

Fig.C.T.1 - Gate Charge Circuit (turn-off)

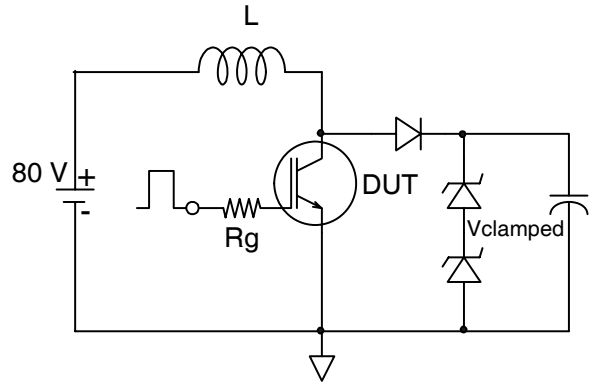

Fig.C.T.2 - RBSOA Circuit

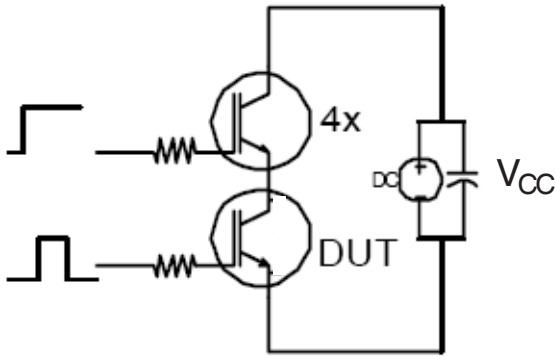

Fig.C.T.3 - S.C. SOA Circuit

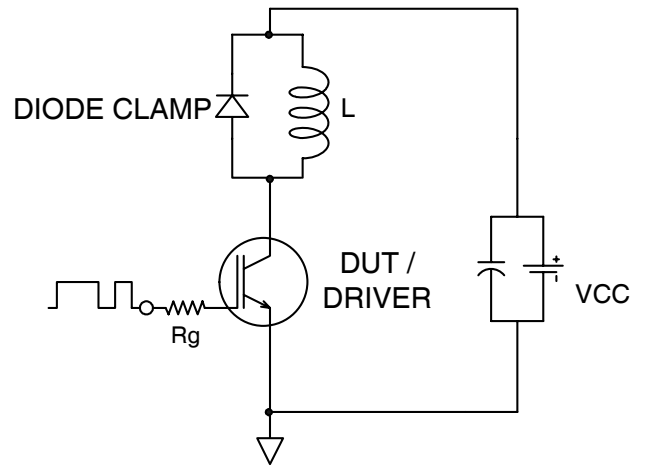

Fig.C.T.4 - Switching Loss Circuit

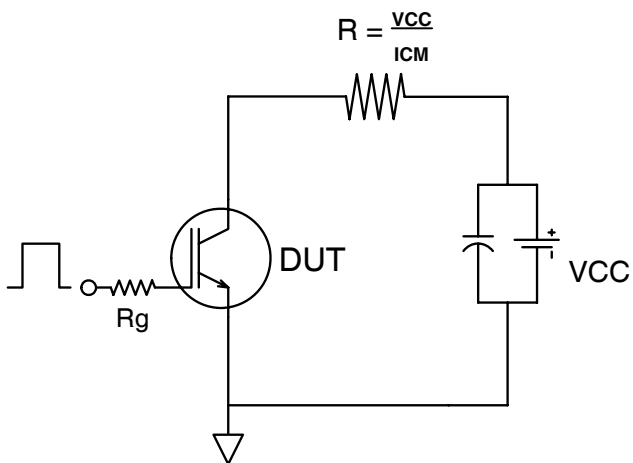

Fig.C.T.5 - Resistive Load Circuit

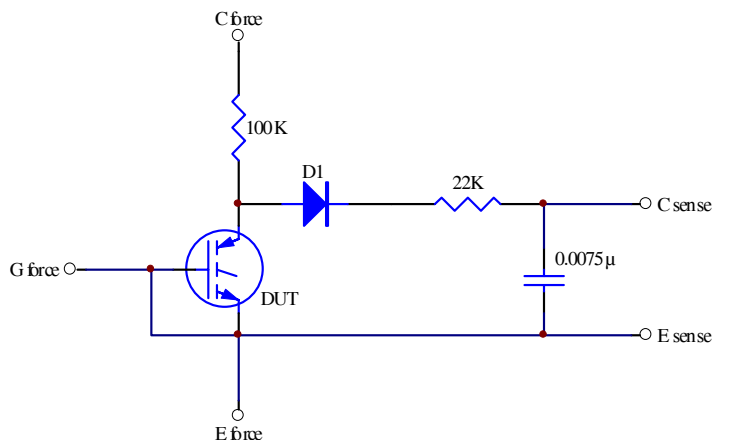

Fig.C.T.6 - BVCES Filter Circuit

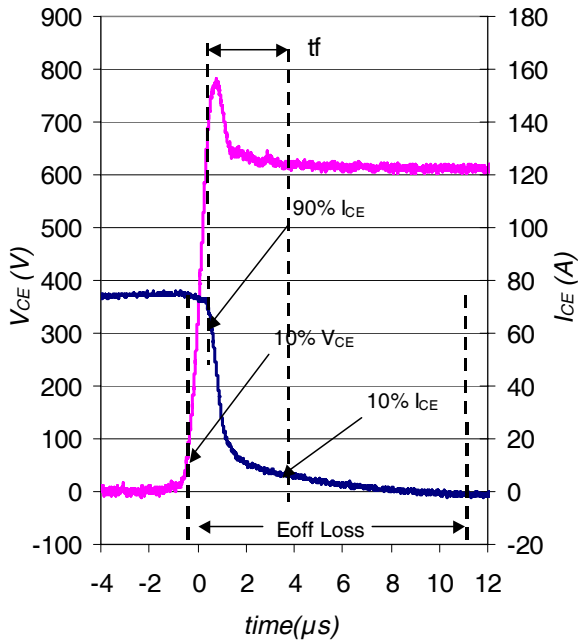

Fig. WF1 - Typ. Turn-off Loss Waveform
@ $T_J = 175^\circ\text{C}$ using Fig. CT.4

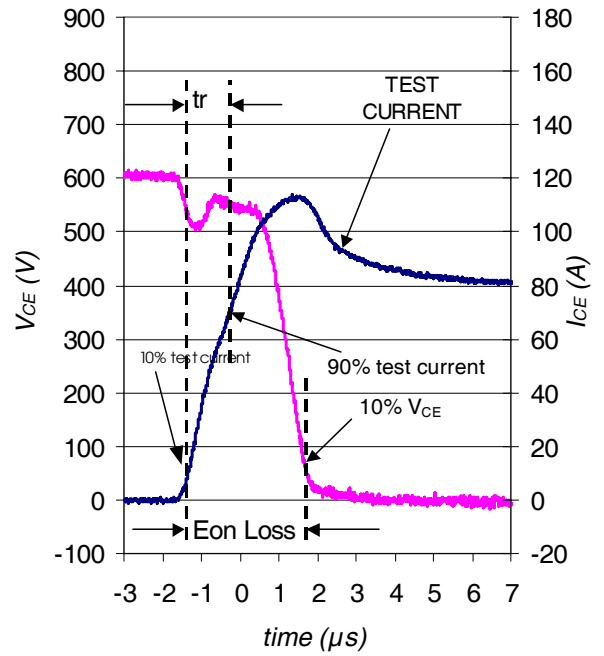

Fig. WF2 - Typ. Turn-on Loss Waveform
@ $T_J = 175^\circ\text{C}$ using Fig. CT.4

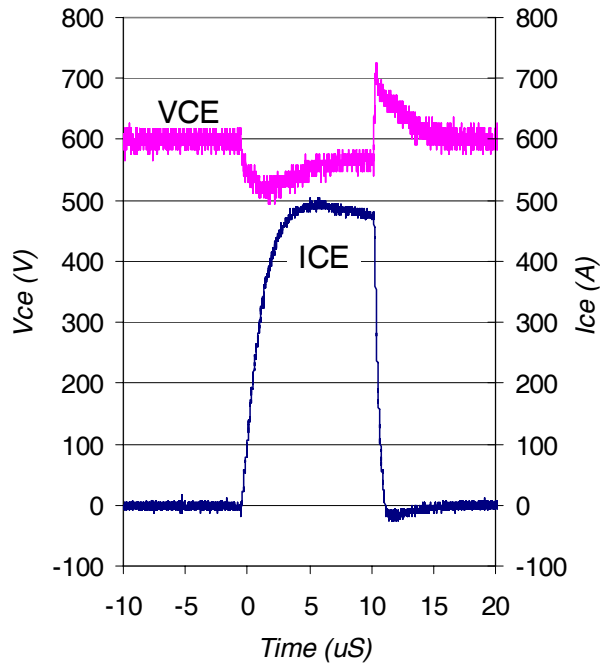
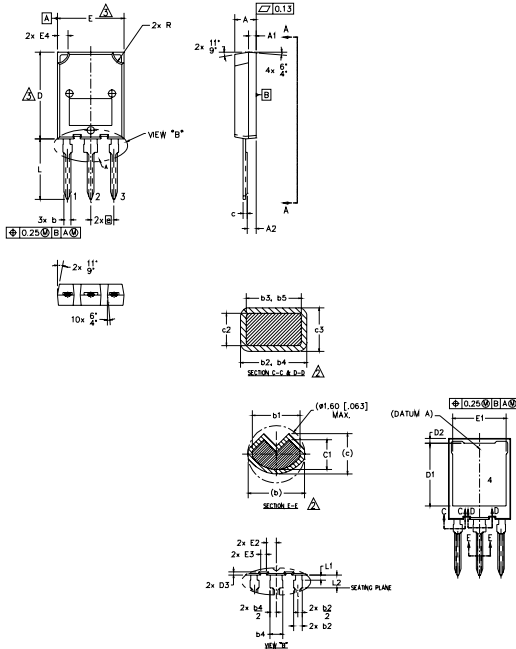

Fig. WF3 - Typ. S.C. Waveform
@ $T_J = 150^\circ\text{C}$ using Fig. CT.3

Case Outline and Dimensions — Super-247



NOTES:
1. DIMENSIONING AND TOLERANCING AS PER ASME Y14.5M-1994
2. DIMENSIONS b1, b3, b5, c1 & c3 APPLY TO BASE METAL ONLY.
3. DIMENSION D & E DO NOT INCLUDE MOLD FLASH. MOLD FLASH SHALL NOT EXCEED 0.127 [0.005] PER SIDE. THESE DIMENSIONS ARE MEASURED AT THE OUTER EXTREMES OF THE PLASTIC BODY.
4. ALL DIMENSIONS SHOWN IN MILLIMETERS.
5. CONTROLLING DIMENSION: MILLIMETER.
6. OUTLINE CONFORMS TO JEDEC OUTLINE TO-274AA

SYMBOL	DIMENSIONS				NOTES
	MILLIMETERS		INCHES		
	MIN.	MAX.	MIN.	MAX.	
A	4.50	5.50	.177	.217	
A1	1.45	2.15	.057	.085	
A2	1.65	2.35	.065	.093	
b	1.45	1.60	.054	.063	
b1	1.40	1.50	.055	.059	2
b2	2.00	2.40	.079	.094	
b3	1.95	2.35	.077	.093	2
b4	3.00	3.15	.118	.124	
b5	2.95	3.35	.116	.132	2
c	1.10	1.30	.043	.051	
c1	0.90	1.10	.035	.043	2
c2	0.65	0.85	.026	.033	
c3	0.50	0.70	.020	.028	2
D	19.80	20.80	.780	.819	3
D1	15.50	16.10	.610	.634	
D2	0.70	1.30	.028	.051	
D3	0.75	1.25	.030	.049	
E	15.10	16.10	.594	.634	
E1	13.30	13.90	.524	.547	
E2	2.25	2.70	.089	.109	
E3	1.20	1.70	.047	.067	
E4	2.00	3.00	.079	.118	
e	5.45 BSC		.215 BSC		
L	13.80	14.80	.535	.583	
L1	1.00	1.60	.039	.063	
L2	3.85	4.25	.152	.167	
R	2.00	3.00	.079	.118	

LEAD ASSIGNMENTS

MOSET

- 1.- GATE
- 2.- DRAIN
- 3.- SOURCE
- 4.- DRAIN

IGBT

- 1.- GATE
- 2.- COLLECTOR
- 3.- EMITTER
- 4.- COLLECTOR

Super-247 (TO-274AA) Part Marking Information

EXAMPLE: THIS IS AN IRFPS37N50A WITH
ASSEMBLY LOT CODE 1789
ASSEMBLED ON WW 19, 1997
IN THE ASSEMBLY LINE "C"

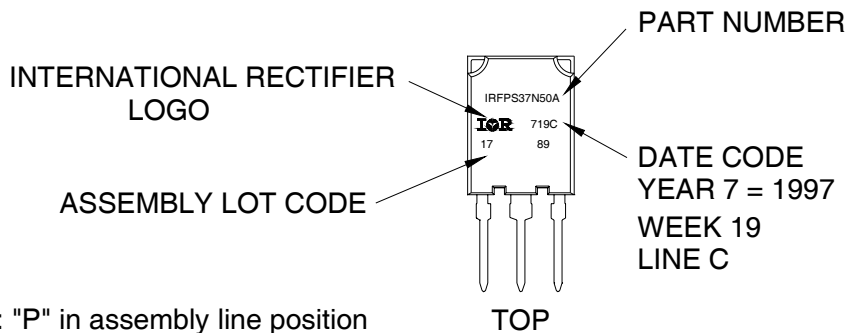

Note: "P" in assembly line position indicates "Lead-Free"

Super-247 package is not recommended for Surface Mount Application.

Note: For the most current drawing please refer to IR website at <http://www.irf.com/package/>

Data and specifications subject to change without notice.
This product has been designed and qualified for Industrial market.
Qualification Standards can be found on IR's Web site.

Looking for pricing, stock, or lifecycle information?

Click below to explore more details on WIN SOURCE:

- ⊖ [View IRG7PSH73K10 on WIN SOURCE](#)
- ⊖ [Infineon Technologies](#) Information

Optimize Your Supply Chain with WIN SOURCE Solutions

- ✓ Global Sourcing Solution
- ✓ Obsolete Management
- ✓ Cost Control Management
- ✓ Shortage Management
- ✓ Alternative Solution
- ✓ Excess Inventory Management