

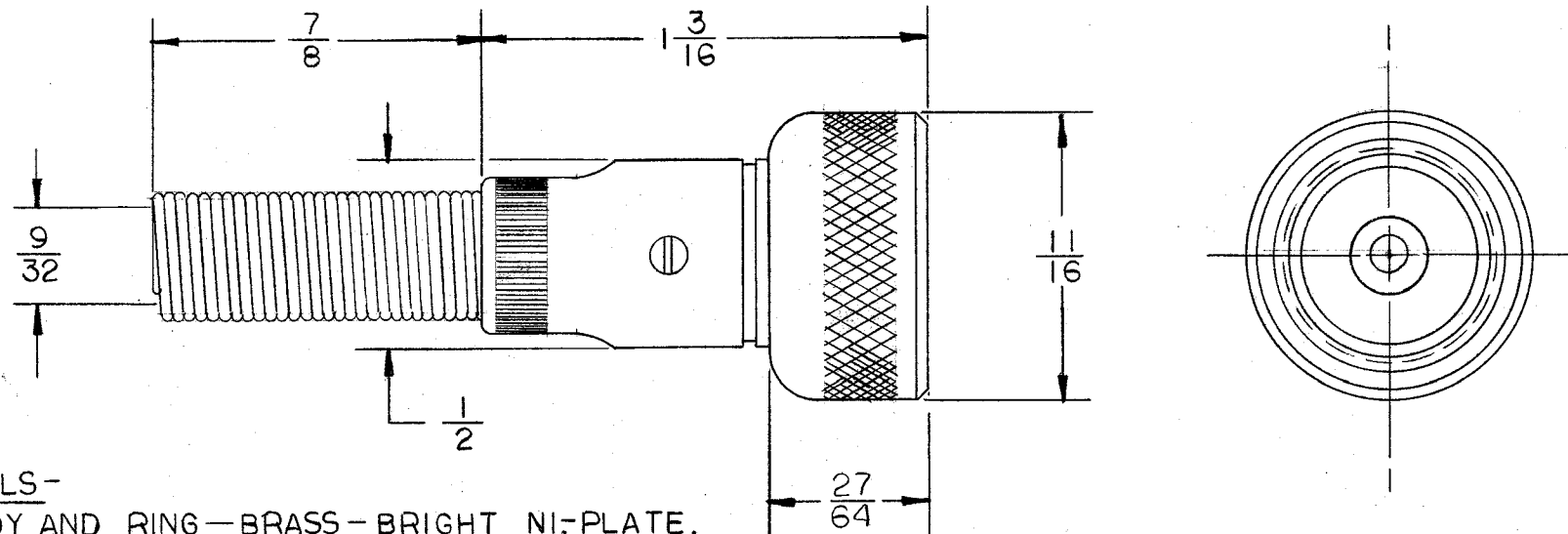

**THE DATASHEET OF**  
**2501F**





MATERIALS-

- 1-BODY AND RING-BRASS-BRIGHT NI-PLATE.
- 2-INSULATOR-PAPER BASE PHENOLIC.
- 3-CORD PROTECTOR SLEEVE-MUSIC WIRE-TINNED.
- 4-EYELET-BRASS-HOT TINNED.
- 5-SET SCREW-STEEL-NI-PLATED.

★ STAR SYMBOL DENOTES CRITICAL DIMENSION, SEE S/C ENGINEERING STANDARD ES-0001.	SIZE	WIDTH	MULT.	LBS. PER M	TEMPER
---	------	-------	-------	------------	--------

THIS DRAWING DESCRIBES A DESIGN CONSIDERED PROPRIETARY IN NATURE, DEVELOPED AND MANUFACTURED BY SWITCHCRAFT, INC., AND IS RELEASED ON A CONFIDENTIAL BASIS FOR IDENTIFICATION PURPOSE ONLY.

- UNLESS OTHERWISE SPECIFIED:
- 1- DECIMAL DIMENSIONS ± .005
  - 2- FRACTIONAL DIMENSIONS ± 1/64
  - 3- ANGLES ± 1/2°
  - 4- ALL DIA'S CONCENTRIC WITHIN .005 T.I.R.
  - 5- ALL DIMENSIONS IN INCHES
  - 6- FOR THREADS USE UNIFIED PLUG AND RING GAGES ONLY.
  - 7- REMOVE ALL BURRS.
  - 8- PART TO BE FABRICATED AS SPECIFIED. MAKE NO DIMENSIONAL ALLOWANCES FOR APPLIED FINISHES, I.E., PLATING, PAINTING, ETC.
  - 9- HOLES ON SAME CENTERLINE MUST BE ALIGNED WITHIN ± .002

DRAWN BY HCJ	DATE 12-29-75
CHECKED BY W/H	DATE 12-31-75
APPROVED BY	DATE

FINISH	PER FINISH SPEC. NO. _____
MATERIAL	PER MAT. SPEC. NO. _____

SCALE (2X)
FIRST USED ON



NAME  
SINGLE CONTACT  
MICROPHONE CONN.  
FEMALE TYPE

PART NO. 2501 F	ISSUE A
SHEET	OF

DO NOT SCALE DRAWING

ISS SYM	REVISION	BY	DATE
A	RE-DRAWN ECO 1/6/74	W	12-31-75



## Looking for pricing, stock, or lifecycle information?

Click below to explore more details on WIN SOURCE:

 [View 2501F](#) on WIN SOURCE

 [Switchcraft Inc.](#) Information

## Optimize Your Supply Chain with WIN SOURCE Solutions

-  Global Sourcing Solution
-  Obsolete Management
-  Cost Control Management
-  Shortage Management
-  Alternative Solution
-  Excess Inventory Management