



**THE DATASHEET OF  
IML-0686**



Fresnel Lens

IML-0686

Product Specification

**1. Scope**

This product specification is applied to fresnel lens IML-0686 used for Pyroelectric infrared sensor IRA-S210ST01 to detect infrared ray. Please contact us when using this product for any other applications than described in the above.

**2. Murata Part Number**

IML-0686

**3. Outline Drawing and Dimensions**

See Figure 1.

**4. Material etc.**

## 4-1 Material

High density polyethylene

## 4-2 Refractive Index

1.51

## 4-3 Transmittance

See Figure 3.

## 4-4 Color

IML-0686 : Natural White

IML-0686G : Dark Gray

IML-0686W : White

**5. Lens**

## 5-1 Field of View

See Figure 2.

**6. Operating Temperature**

-25 ~ 60°C

**7. Storage Temperature**

-30 ~ 80°C

**8 ⚠ Caution****8-1 Limitation of Applications**

Please contact us before using our products for the applications listed below which require especially high reliability for the prevention of defects which might directly cause damage to the third party's life, body or property.

1. Aircraft equipment
2. Aerospace equipment
3. Undersea equipment
4. Power plant control equipment
5. Medical equipment
6. Transportation equipment (vehicles, trans, ships, etc.)
7. Traffic signal equipment
8. Disaster prevention / crime prevention equipment
9. Data-processing equipment
10. Application of similar complexity and/or reliability requirement to the applications listed in the above

**8-2 Fail-safe**

Be sure to provide an appropriate fail-safe function on your product to prevent a second damage that may be caused by the abnormal function or the failure of our product.

**9. Caution in use**

## 9-1 Notice in design

- 1) Please set the direction of the tab of fresnel lens to the tab of the sensor.
- 2) To bring pyro-Element into the focus of fresnel lens, Please push the sensor until the step inside the fresnel lens.
- 3) Please add any mechanism for preventing dislocation or for preventing coming off from the sensor because of transition fit between sensor and fresnel lens.
- 4) Please avoid using the fresnel lens in the following conditions because it may cause failure or malfunction ;
  - a) in such a fluid as water, alcohol etc. corrosive gas (SO<sub>2</sub>, Cl<sub>2</sub>, NO<sub>x</sub> etc.) or sea breeze.
  - b) in high humidity.
  - c) in a place exposed directly to sun light or headlight of automobile.
  - d) in a place exposed directly to blow from air-conditioner or heater.
  - e) in such a place where infrared ray is shaded.
  - f) in any other place similar to the above (a) through (e).

## 9-2 Notice in handling and storage

- 1) Optical filter of sensor should not be scratched or soiled.
- 2) Strong shock should be avoided.
- 3) High temperature, high humidity, fluid as water or alcohol etc., corrosive gas (SO<sub>2</sub>, Cl<sub>2</sub>, NO<sub>x</sub> etc.) and sea breeze should be avoided.
- 4) Use the products within 6 months after receiving.

**10. ⚠ Note**

- 1) Please make sure that your product has been evaluated in view of your specifications with our product being mounted to your product.
- 2) You are requested not to use our product deviating from the agreed specifications.
- 3) We consider it not to appropriate to include any terms and conditions with regard to the business transaction in the product specifications, drawings or other technical documents. Therefore, if your technical documents as above include such terms and conditions such as warranty clause, product liability clause, or intellectual property infringement liability clause, they will be deemed to be invalid.

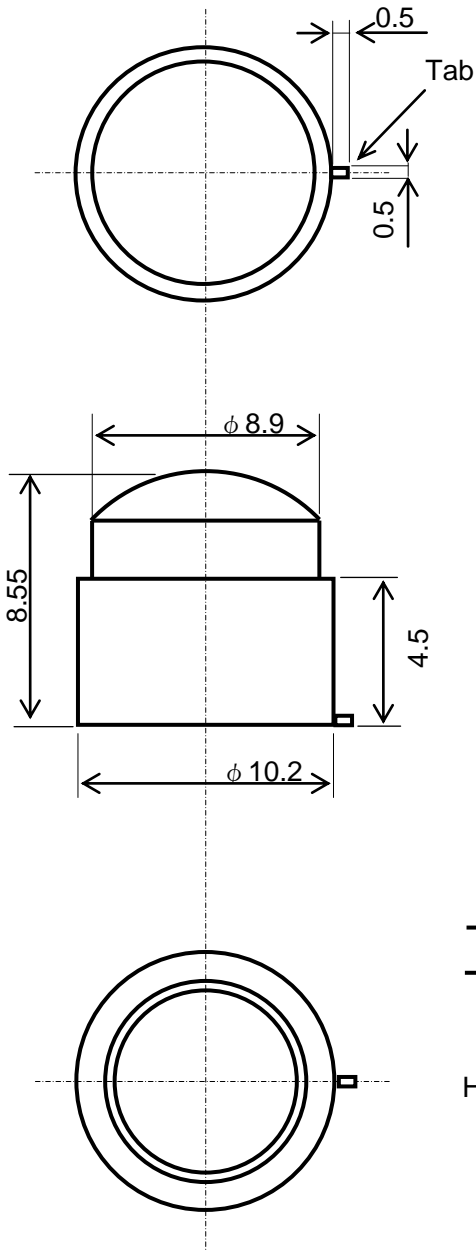

Unit : mm  
 General tolerance :  $\pm 0.2$

- ※Please set the direction of the tab on the fresnel lens to the tab on the sensor.
- ※To bring pyro-Element into the focus of fresnel lens, Please push the sensor until the step inside the fresnel lens.
- ※Please design the housing that the sensor does not receive infrared ray through the area shown as diagram in Figure A.
- ※Please design housing and set of sensor and lens to prevent from dislocation and coming off .

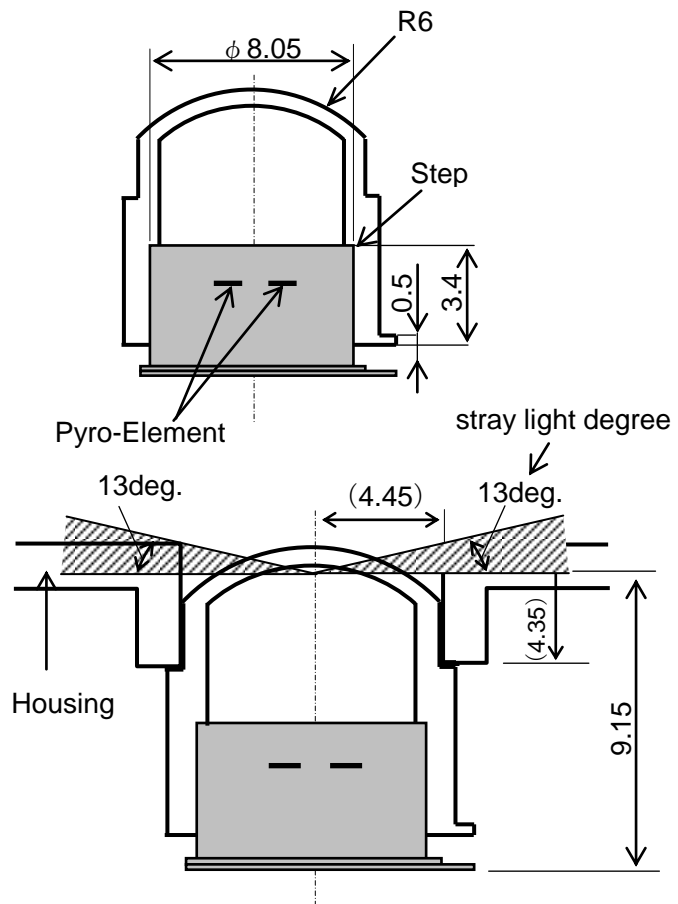
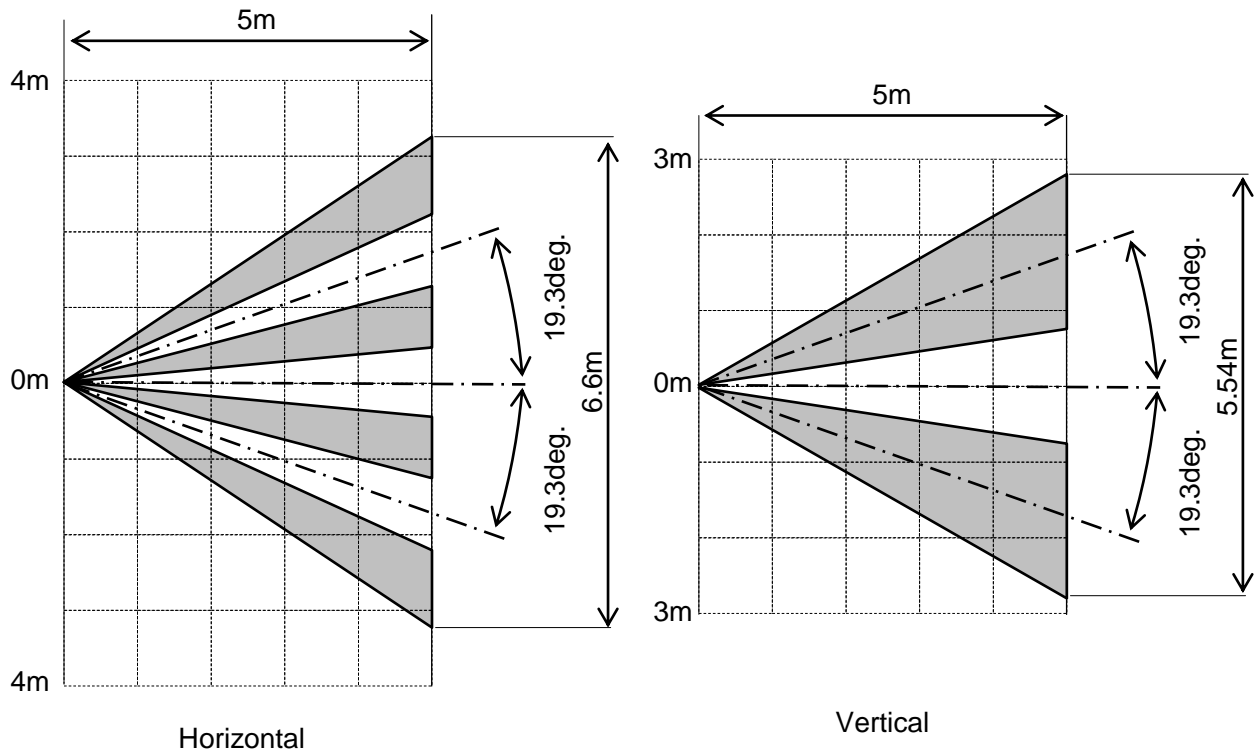

Figure A

An example of a design of the housing

Figure 1



※Assembled with Murata sensor IRA-S210 series

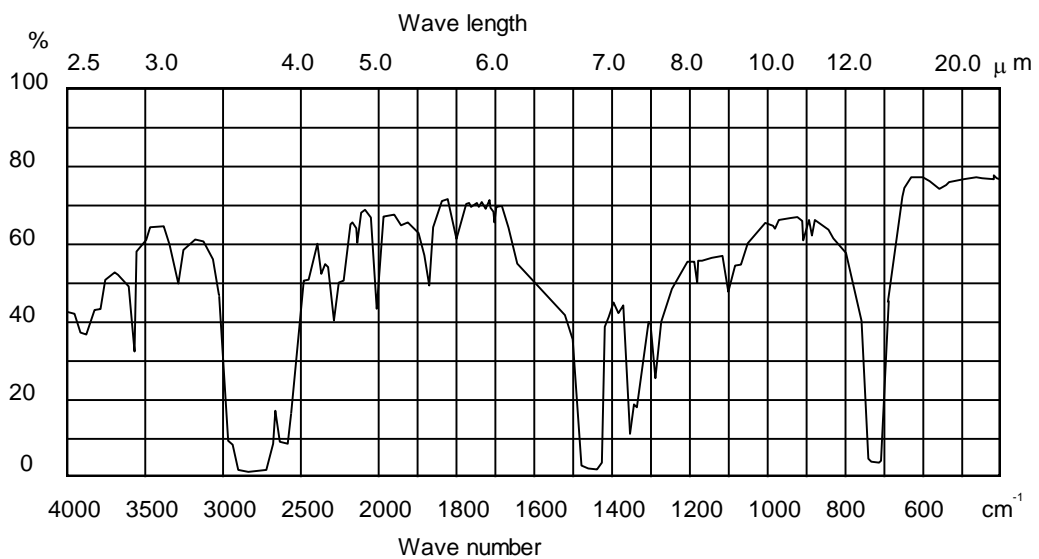

**Figure2**



**Figure 3. Transmittance**

## Looking for pricing, stock, or lifecycle information?

Click below to explore more details on WIN SOURCE:

-  [View IML-0686 on WIN SOURCE](#)
-  [Murata Electronics North America Information](#)

## Optimize Your Supply Chain with WIN SOURCE Solutions

-  Global Sourcing Solution
-  Obsolete Management
-  Cost Control Management
-  Shortage Management
-  Alternative Solution
-  Excess Inventory Management