



**THE DATASHEET OF
NGTG12N60TF1G**





NGTG12N60TF1G

N-Channel IGBT

600V, 12A, $V_{CE(sat)}$;1.4V TO-3PF-3L

ON Semiconductor®

<http://onsemi.com>

Features

- $V_{CE(sat)}$ =1.4V typ. (I_C =12A, V_{GE} =15V)
- Low switching loss in higher frequency applications
- Enhancement type
- 5 μ s short circuit capability
- Adoption of full isolation type package

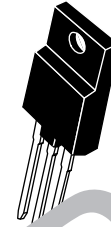

TO-3PF-3L

Applications

- Power factor correction of white goods appliance
- General purpose inverter

Specifications

Absolute Maximum Ratings at $T_a = 25^\circ\text{C}$, Unless otherwise specified

Parameter	Symbol	Conditions	Ratings	Unit	
Collector to Emitter Voltage	V_{CES}		600	V	
Gate to Emitter Voltage	V_{GES}		± 20	V	
Collector Current (DC)	I_C^{*1}	Limited by T_{jmax}	@ $T_c=25^\circ\text{C}^{*1}$	24	A
			@ $T_c=100^\circ\text{C}^{*2}$	12	A
Collector Current (Pulse)	I_{CP}	Pulse width Limited by T_{jmax} (Ref:ASO graph)	88	A	
Allowable Power Dissipation	P_{Dmax}	$T_c=25^\circ\text{C}$ (Our ideal heat dissipation condition) ^{*2}	54	W	
Junction Temperature	T_j		150	$^\circ\text{C}$	
Storage Temperature	T_{stg}		- 55 to +150	$^\circ\text{C}$	

Note : ^{*1} Collector Current is calculated from the following formula.

$$I_C = \frac{T_{jmax} - T_c}{R_{th(jc)}} \times V_{CE(sat)max} \times I_C(1c)$$

^{*2} Our condition is radiation from backside.

The method is applying silicone grease to the backside of the device and attaching the device to water-cooled radiator made of aluminium.

Stresses exceeding Maximum Ratings may damage the device. Maximum Ratings are stress ratings only. Functional operation above the Recommended Operating Conditions is not implied. Extended exposure to stresses above the Recommended Operating Conditions may affect device reliability.

Electrical Characteristics at $T_a = 25^\circ\text{C}$, Unless otherwise specified

Parameter	Symbol	Conditions	Ratings			Unit
			min	typ	max	
Collector to Emitter Breakdown Voltage	$V_{(BR)CES}$	$I_C=500\mu\text{A}$, $V_{GE}=0\text{V}$	600			V
Collector to Emitter Cut off Current	I_{CES}	$V_{CE}=600\text{V}$, $V_{GE}=0\text{V}$	$T_c=25^\circ\text{C}$		10	μA
			$T_c=125^\circ\text{C}$		1	mA
Gate to Emitter Leakage Current	I_{GES}	$V_{GE}=\pm 20\text{V}$, $V_{CE}=0\text{V}$			± 100	nA
Gate to Emitter Threshold Voltage	$V_{GE(th)}$	$V_{CE}=20\text{V}$, $I_C=250\mu\text{A}$	4.5		6.5	V
Collector to Emitter Saturation Voltage	$V_{CE(sat)}$	$V_{GE}=15\text{V}$, $I_C=12\text{A}$	$T_c=25^\circ\text{C}$	1.4	1.6	V
			$T_c=125^\circ\text{C}$	1.6		V
Input Capacitance	C_{ies}			2000		pF
Output Capacitance	C_{oes}	$V_{CE}=20\text{V}$, $f=1\text{MHz}$		60		pF
Reverse Transfer Capacitance	C_{res}			50		pF

Continued on next page.

ORDERING INFORMATION

See detailed ordering and shipping information on page 7 of this data sheet.

NGTG12N60TF1G

Continued from preceding page.

Parameter	Symbol	Conditions	Ratings			Unit
			min	typ	max	
Turn-ON Delay Time	$t_{d(on)}$	$V_{CC}=300V, I_C=15A$ $R_G=30\Omega, L=200\mu H$ $V_{GE}=0V/15V$ $V_{clamp}=400V$ See Fig.1, See Fig.2		55		ns
Rise Time	t_r			30		ns
Turn-ON Time	t_{on}			330		ns
Turn-OFF Delay Time	$t_{d(off)}$			200		ns
Fall Time	t_f			110		ns
Turn-OFF Time	t_{off}			350		ns
Total Gate Charge	Q_g	$V_{CE} =300V, V_{GE}=15V, I_C=15A$		84		nC
Gate to Emitter Charge	Q_{ge}			16		nC
Gate to Collector "Miller" Charge	Q_{gc}			37		nC

Thermal Characteristics at $T_a = 25^\circ C$, Unless otherwise specified

Parameter	Symbol	Conditions	Ratings	Unit
Thermal Resistance (junction- Case)	$R_{th(j-c)}$	$T_c=25^\circ C$ (our ideal heat dissipation condition)*2	2.33	$^\circ C/W$
Thermal Resistance (junction- atmosphere)	$R_{th(j-a)}$		47.5	$^\circ C/W$

DISCONTINUED
 THIS DEVICE IS NOT RECOMMENDED FOR NEW DESIGN
 PLEASE CONTACT YOUR onsemi
 REPRESENTATIVE FOR INFORMATION

NGTG12N60TF1G

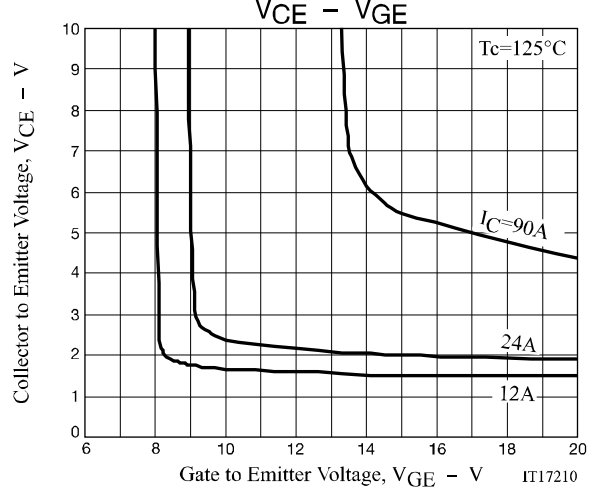
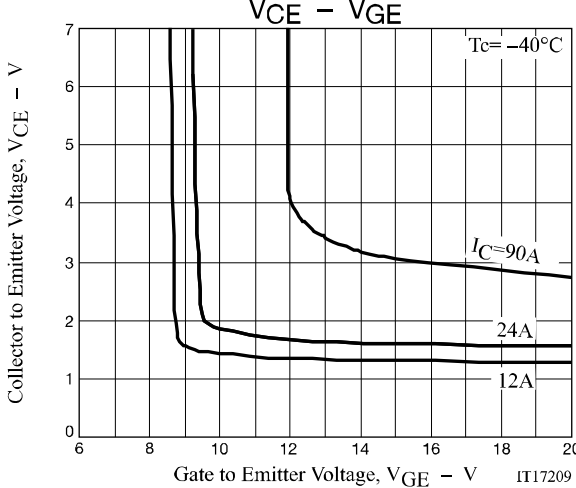
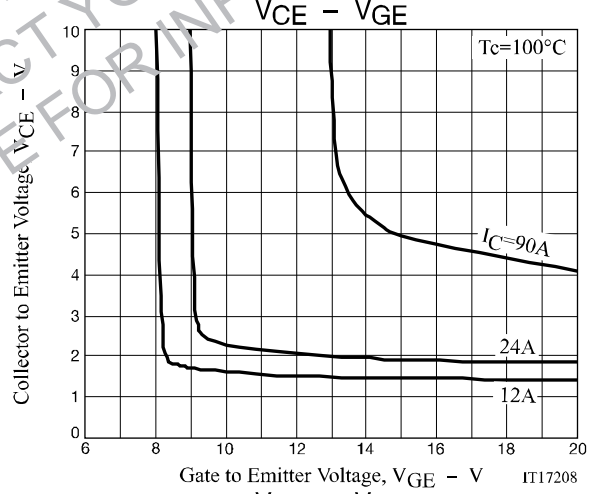
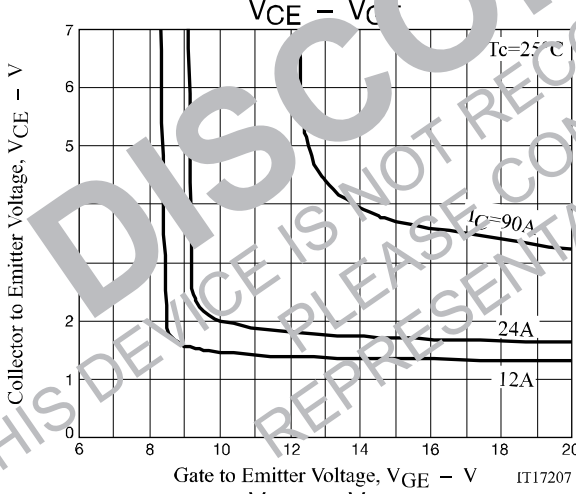
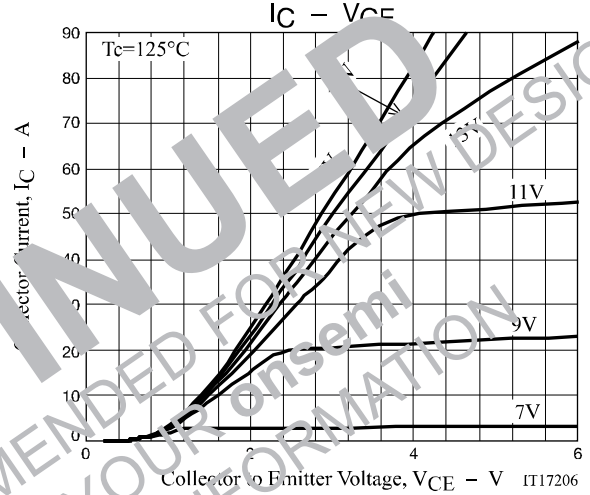
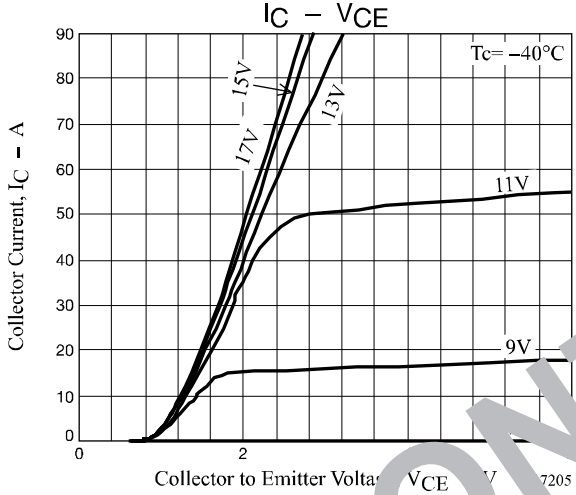
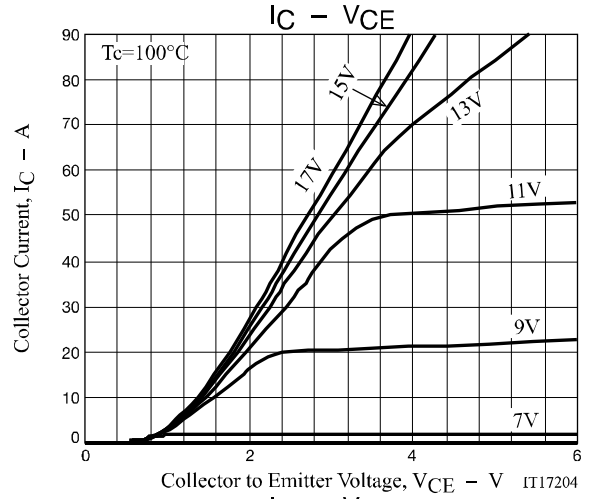
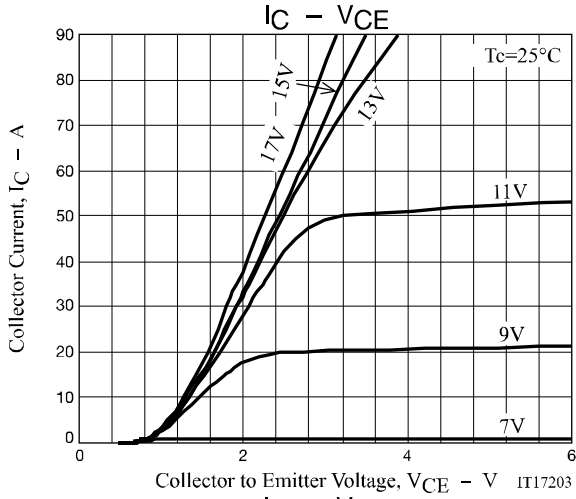

NGTG12N60TF1G

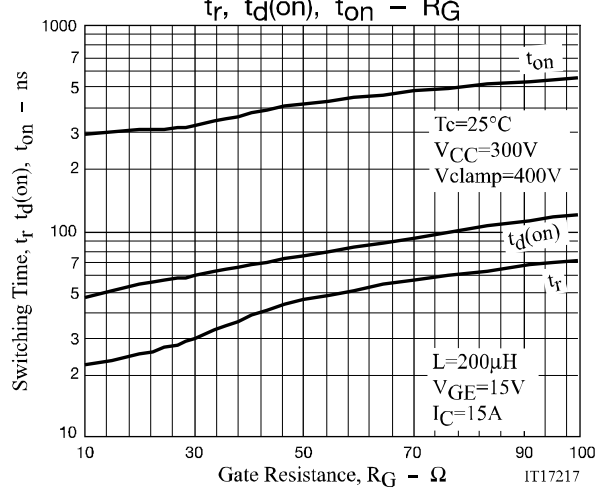
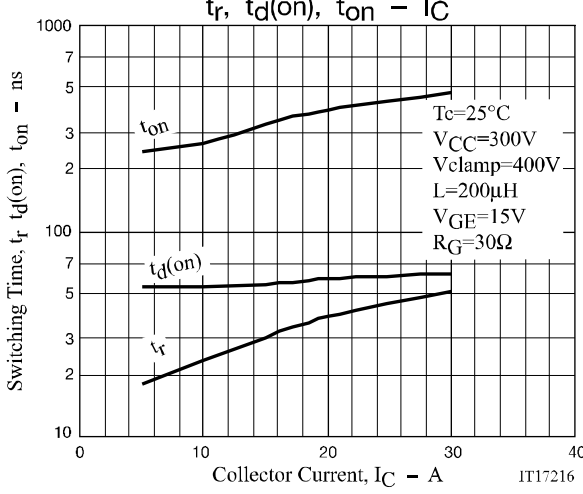
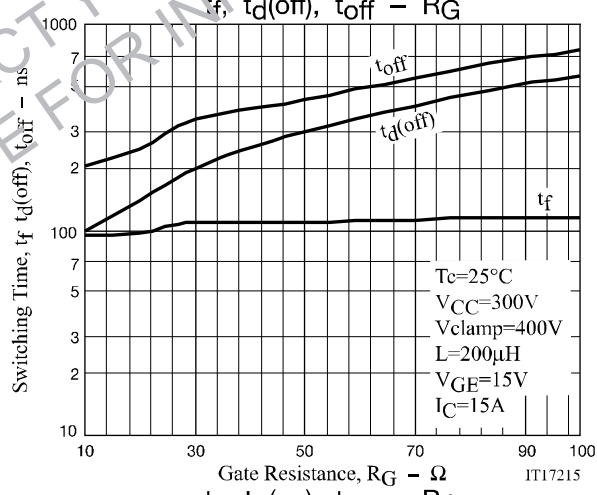
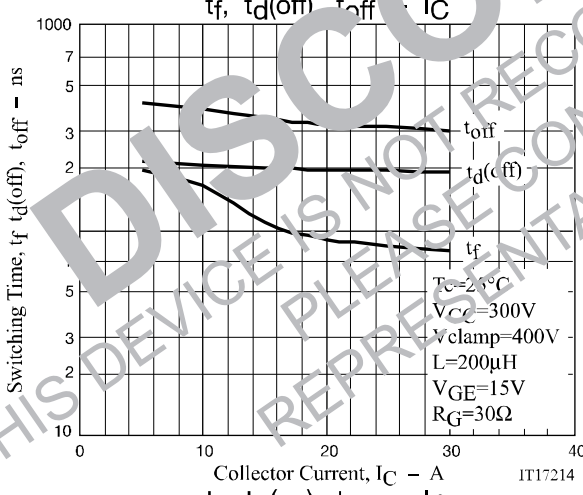
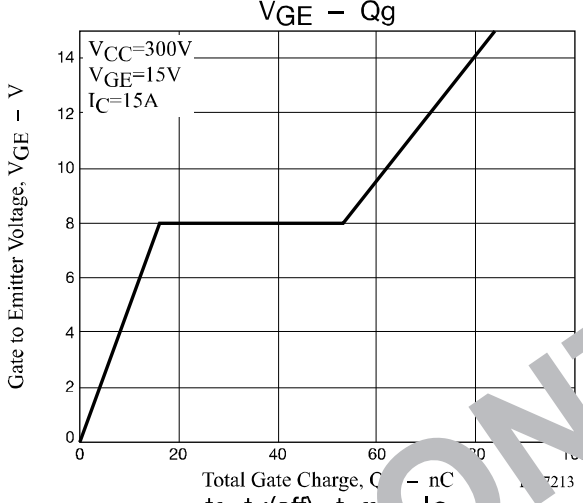
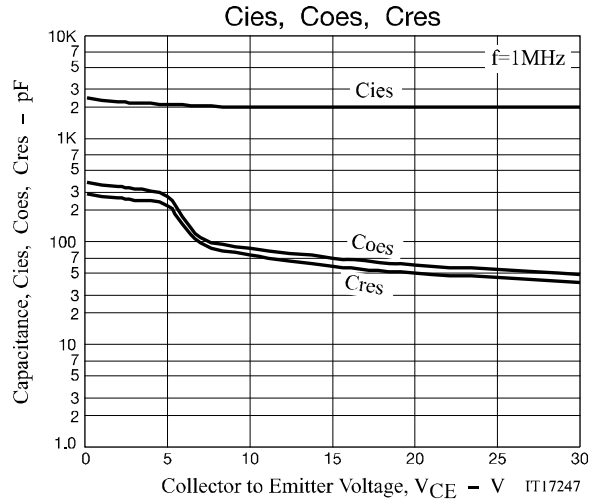
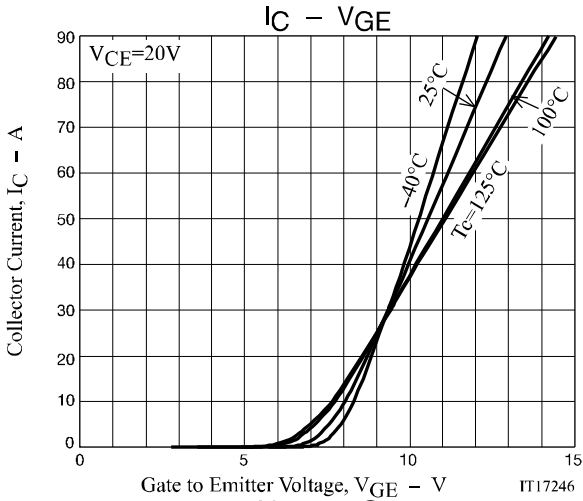

DISCONTINUED

THIS DEVICE IS NOT RECOMMENDED FOR NEW DESIGN

PLEASE CONTACT YOUR onsemi REPRESENTATIVE FOR INFORMATION

NGTG12N60TF1G

Forward Bias A S O

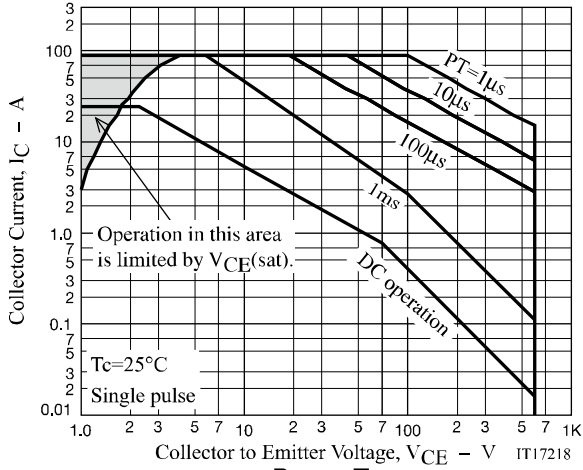

Reverse Bias A S O

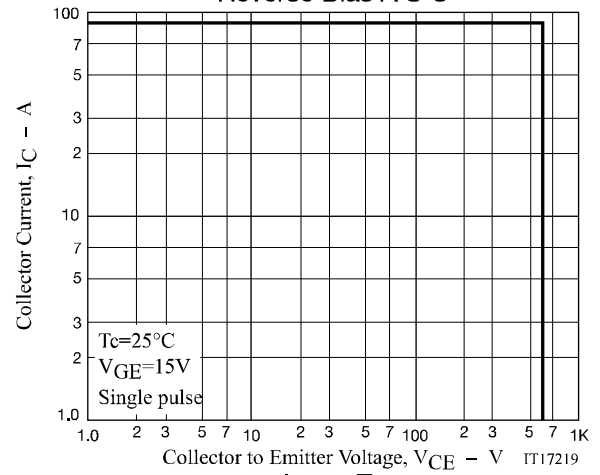

$P_D - T_c$

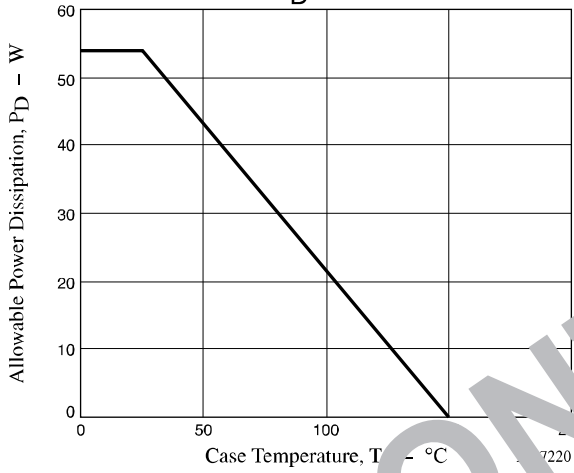

$I_C - T_c$

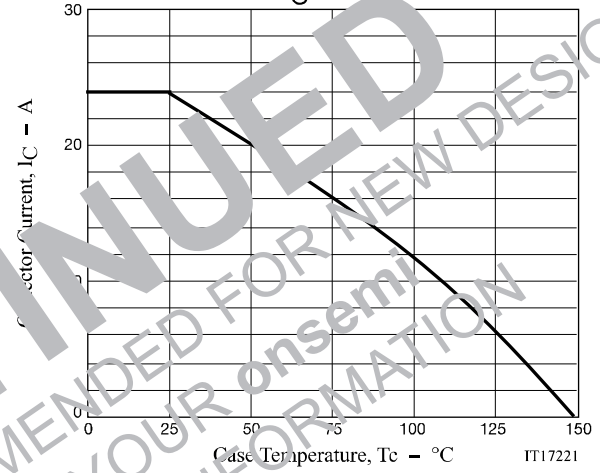

DISCONTINUED

THIS DEVICE IS NOT RECOMMENDED FOR NEW DESIGN

PLEASE CONTACT YOUR onsemi REPRESENTATIVE FOR INFORMATION

NGTG12N60TF1G

Ordering & Package Information

Device	Package	Shipping	note
NGTG12N60TF1G	TO-3PF-3L SC-94	30 pcs. / tube	Pb-Free

Marking

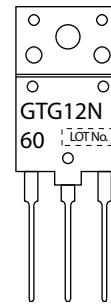

Fig.1 Switching Time Test Circuit

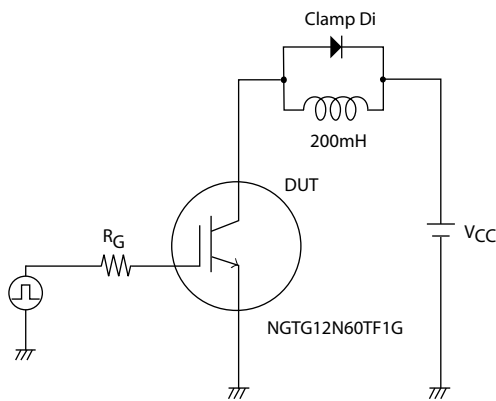
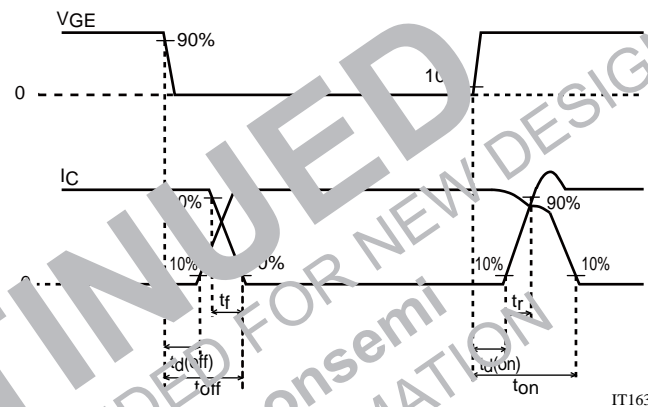

Fig.2 Timing Chart



IT16383

DISCONTINUED FOR NEW DESIGN

THIS DEVICE IS NOT RECOMMENDED FOR NEW DESIGN
PLEASE CONTACT YOUR onsemi REPRESENTATIVE FOR INFORMATION

ON Semiconductor and the ON logo are registered trademarks of Semiconductor Components Industries, LLC (SCILLC). SCILLC owns the rights to a number of patents, trademarks, copyrights, trade secrets, and other intellectual property. A listing of SCILLC's product/patent coverage may be accessed at www.onsemi.com/site/pdf/Patent-Marking.pdf. SCILLC reserves the right to make changes without further notice to any products herein. SCILLC makes no warranty, representation or guarantee regarding the suitability of its products for any particular purpose, nor does SCILLC assume any liability arising out of the application or use of any product or circuit, and specifically disclaims any and all liability, including without limitation special, consequential or incidental damages. "Typical" parameters which may be provided in SCILLC data sheets and/or specifications can and do vary in different applications and actual performance may vary over time. All operating parameters, including "Typicals" must be validated for each customer application by customer's technical experts. SCILLC does not convey any license under its patent rights nor the rights of others. SCILLC products are not designed, intended, or authorized for use as components in systems intended for surgical implant into the body, or other applications intended to support or sustain life, or for any other application in which the failure of the SCILLC product could create a situation where personal injury or death may occur. Should Buyer purchase or use SCILLC products for any such unintended or unauthorized application, Buyer shall indemnify and hold SCILLC and its officers, employees, subsidiaries, affiliates, and distributors harmless against all claims, costs, damages, and expenses, and reasonable attorney fees arising out of, directly or indirectly, any claim of personal injury or death associated with such unintended or unauthorized use, even if such claim alleges that SCILLC was negligent regarding the design or manufacture of the part. SCILLC is an Equal Opportunity/Affirmative Action Employer. This literature is subject to all applicable copyright laws and is not for resale in any manner.

Looking for pricing, stock, or lifecycle information?

Click below to explore more details on WIN SOURCE:

 [View NGTG12N60TF1G on WIN SOURCE](#)

 [ON Semiconductor](#) Information

Optimize Your Supply Chain with WIN SOURCE Solutions

-  Global Sourcing Solution
-  Obsolete Management
-  Cost Control Management
-  Shortage Management
-  Alternative Solution
-  Excess Inventory Management