



**THE DATASHEET OF
MC14526BDWG**



Presettable 4-Bit Down Counters

MC14526B

The MC14526B binary counter is constructed with MOS P-channel and N-channel enhancement mode devices in a monolithic structure.

This device is presettable, cascadable, synchronous down counter with a decoded “0” state output for divide-by-N applications. In single stage applications the “0” output is applied to the Preset Enable input. The Cascade Feedback input allows cascade divide-by-N operation with no additional gates required. The Inhibit input allows disabling of the pulse counting function. Inhibit may also be used as a negative edge clock.

This complementary MOS counter can be used in frequency synthesizers, phase-locked loops, and other frequency division applications requiring low power dissipation and/or high noise immunity.

Features

- Supply Voltage Range = 3.0 Vdc to 18 Vdc
- Logic Edge-Clocked Design: Incremented on Positive Transition of Clock or Negative Transition of Inhibit
- Asynchronous Preset Enable
- Capable of Driving Two Low-Power TTL Loads or One Low-Power Schottky TTL Load Over the Rated Temperature Range
- This Device is Pb-Free and is RoHS Compliant

MAXIMUM RATINGS

Rating	Symbol	Value	Unit
DC Supply Voltage Range	V_{DD}	-0.5 to +18.0	V
Input or Output Voltage Range (DC or Transient)	V_{in}, V_{out}	-0.5 to $V_{DD} + 0.5$	V
Input or Output Current (DC or Transient) per Pin	I_{in}, I_{out}	±10	mA
Power Dissipation per Package (Note 1)	P_D	500	mW
Operating Temperature Range	T_A	-55 to +125	°C
Storage Temperature Range	T_{stg}	-65 to +150	°C
Lead Temperature (8-Second Soldering)	T_L	260	°C

Stresses exceeding those listed in the Maximum Ratings table may damage the device. If any of these limits are exceeded, device functionality should not be assumed, damage may occur and reliability may be affected. Operating the device outside its recommended conditions, but still within its maximum rated limits may not cause immediate damage. However, doing so can lead to reduced performance, unpredictable behavior, and potentially shorten the device's lifespan or reliability.

1. Temperature Derating: “D/DW” Package: -7.0 mW/°C From 65 °C To 125 °C

This device contains protection circuitry to guard against damage due to high static voltages or electric fields. However, precautions must be taken to avoid applications of any voltage higher than maximum rated voltages to this high-impedance circuit. For proper operation, V_{in} and V_{out} should be constrained to the range $V_{SS} \leq (V_{in} \text{ or } V_{out}) \leq V_{DD}$.

Unused inputs must always be tied to an appropriate logic voltage level (e.g., either V_{SS} or V_{DD}). Unused outputs must be left open.

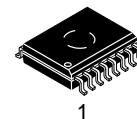

SOIC-16 WB
DW SUFFIX
CASE 751G

MARKING DIAGRAM

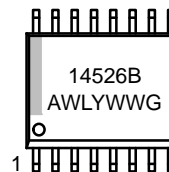

- A = Assembly Location
- WL, L = Wafer Lot
- YY, Y = Year
- WW, W = Work Week
- G = Pb-Free Package

ORDERING INFORMATION

See detailed ordering and shipping information in the package dimensions section on page 8 of this data sheet.

FUNCTION TABLE

Inputs					Output	Resulting Function
Clock	Reset	Inhibit	Preset Enable	Cascade Feedback	"0"	
X	H	X	L	L	L	Asynchronous reset*
X	H	X	H	L	H	Asynchronous reset
X	H	X	X	H	H	Asynchronous reset
X	L	X	H	X	L	Asynchronous preset
L	L	H	L	X	L	Decrement inhibited
			L	X	L	Decrement inhibited
H	L	L	L	L	L	No change** (inactive edge)
			L	L	L	No change** (inactive edge)
			L	L	L	Decrement**
			L	L	L	Decrement**

X = Don't Care

NOTES:

* Output "0" is low when reset goes high only if PE and CF are low.

** Output "0" is high when reset is low, only if CF is high and count is 0000.

PIN DESCRIPTIONS

Preset Enable (Pin 3) — If Reset is low, a high level on the Preset Enable input asynchronously loads the counter with the programmed values on P0, P1, P2, and P3.

Inhibit (Pin 4) — A high level on the Inhibit input prevents the Clock from decrementing the counter. With Clock (pin 6) held high, Inhibit may be used as a negative edge clock input.

Clock (Pin 6) — The counter decrements by one for each rising edge of Clock. See the Function Table for level requirements on the other inputs.

Reset (Pin 10) — A high level on Reset asynchronously forces Q0, Q1, Q2, and Q3 low and, if Cascade Feedback is high, causes the "0" output to go high.

"0" (Pin 12) — The "0" (Zero) output issues a pulse one clock period wide when the counter reaches terminal count (Q0 = Q1 = Q2 = Q3 = low) if Cascade Feedback is high and Preset Enable is low. When presetting the counter to a value

other than all zeroes, the "0" output is valid after the rising edge of Preset Enable (when Cascade Feedback is high). See the Function Table.

Cascade Feedback (Pin 13) — If the Cascade Feedback input is high, a high level is generated at the "0" output when the count is all zeroes. If Cascade Feedback is low, the "0" output depends on the Preset Enable input level. See the Function Table.

P0, P1, P2, P3 (Pins 5, 11, 14, 2) — These are the preset data inputs. P0 is the LSB.

Q0, Q1, Q2, Q3 (Pins 7, 9, 15, 1) — These are the synchronous counter outputs. Q0 is the LSB.

VSS (Pin 8) — The most negative power supply potential. This pin is usually ground.

VDD (Pin 16) — The most positive power supply potential. VDD may range from 3.0 to 18 V with respect to VSS.

STATE DIAGRAM
MC14526B

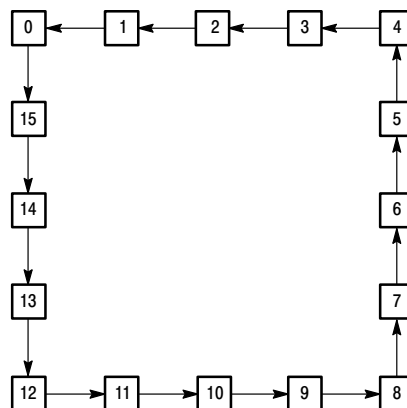

MC14526B

ELECTRICAL CHARACTERISTICS (Voltages Referenced to V_{SS})

Characteristic	Symbol	V_{DD} Vdc	-55 °C		25 °C			125 °C		Unit	
			Min	Max	Min	Typ (Note 2)	Max	Min	Max		
Output Voltage $V_{in} = V_{DD}$ or 0	"0" Level	V_{OL}	5.0	–	0.05	–	0	0.05	–	0.05	Vdc
	$V_{in} = 0$ or V_{DD}	"1" Level	10 15	–	0.05 0.05	–	0 0	0.05 0.05	–	0.05 0.05	
Output Voltage $V_{in} = V_{DD}$ or 0	"0" Level	V_{OH}	5.0	4.95	–	4.95	5.0	–	4.95	–	Vdc
	$V_{in} = 0$ or V_{DD}	"1" Level	10 15	9.95 14.95	–	9.95 14.95	10 15	–	9.95 14.95	–	
Input Voltage ($V_O = 4.5$ or 0.5 Vdc) ($V_O = 9.0$ or 1.0 Vdc) ($V_O = 13.5$ or 1.5 Vdc)	"0" Level	V_{IL}	5.0	–	1.5	–	2.25	1.5	–	1.5	Vdc
	$V_O = 0.5$ or 4.5 Vdc $V_O = 1.0$ or 9.0 Vdc $V_O = 1.5$ or 13.5 Vdc	"1" Level	10 15	–	3.0 4.0	–	4.50 6.75	3.0 4.0	–	3.0 4.0	
Input Voltage ($V_O = 4.5$ or 0.5 Vdc) ($V_O = 9.0$ or 1.0 Vdc) ($V_O = 13.5$ or 1.5 Vdc)	"0" Level	V_{IH}	5.0	3.5	–	3.5	2.75	–	3.5	–	Vdc
	$V_O = 0.5$ or 4.5 Vdc $V_O = 1.0$ or 9.0 Vdc $V_O = 1.5$ or 13.5 Vdc	"1" Level	10 15	7.0 11	–	7.0 11	5.50 8.25	–	7.0 11	–	
Output Drive Current ($V_{OH} = 2.5$ Vdc) ($V_{OH} = 4.6$ Vdc) ($V_{OH} = 9.5$ Vdc) ($V_{OH} = 13.5$ Vdc)	Source	I_{OH}	5.0	–3.0	–	–2.4	–4.2	–	–1.7	–	mAdc
	$V_{OL} = 0.4$ Vdc $V_{OL} = 0.5$ Vdc $V_{OL} = 1.5$ Vdc	Sink	5.0	0.64	–	0.51	0.88	–	0.36	–	
			10	–0.64	–	–0.51	–0.88	–	–0.36	–	
			15	–1.6	–	–1.3	–2.25	–	–0.9	–	
			15	–4.2	–	–3.4	–8.8	–	–2.4	–	
Input Current		I_{in}	15	–	± 0.1	–	± 0.00001	± 0.1	–	± 1.0	μ Adc
Input Capacitance ($V_{in} = 0$)		C_{in}	–	–	–	–	5.0	7.5	–	–	pF
Quiescent Current (Per Package)			5.0	–	5.0	–	0.005	5.0	–	150	μ Adc
			10	–	10	–	0.010	10	–	300	
			15	–	20	–	0.015	20	–	600	
Total Supply Current (Notes 3, 4) (Dynamic plus Quiescent, Per Package) ($C_L = 50$ pF on all outputs, all buffers switching)			5.0	$I_T = (1.7 \mu\text{A/kHz}) f + I_{DD}$							μ Adc
		10	$I_T = (3.4 \mu\text{A/kHz}) f + I_{DD}$								
		15	$I_T = (5.1 \mu\text{A/kHz}) f + I_{DD}$								

Product parametric performance is indicated in the Electrical Characteristics for the listed test conditions, unless otherwise noted. Product performance may not be indicated by the Electrical Characteristics if operated under different conditions.

2. Data labelled "Typ" is not to be used for design purposes but is intended as an indication of the IC's potential performance.

3. The formulas given are for the typical characteristics only at 25 °C.

4. To calculate total supply current at loads other than 50 pF:

$$I_T(C_L) = I_T(50 \text{ pF}) + (C_L - 50) Vfk$$

where: I_T is in μA (per package), C_L in pF, $V = (V_{DD} - V_{SS})$ in volts, f in kHz is input frequency, and $k = 0.001$.

MC14526B

SWITCHING CHARACTERISTICS ($C_L = 50 \text{ pF}$, $T_A = 25 \text{ }^\circ\text{C}$) (Note 5)

Characteristic	Symbol	V_{DD}	Min	Typ (Note 6)	Max	Unit
Output Rise and Fall Time t_{TLH} , $t_{THL} = (1.5 \text{ ns/pF}) C_L + 25 \text{ ns}$ t_{TLH} , $t_{THL} = (0.75 \text{ ns/pF}) C_L + 12.5 \text{ ns}$ t_{TLH} , $t_{THL} = (0.55 \text{ ns/pF}) C_L + 9.5 \text{ ns}$	t_{TLH} , t_{THL} (Figures 4, 5)	5.0 10 15	– – –	100 50 40	200 100 80	ns
Propagation Delay Time (Inhibit Used as Negative Edge Clock) Clock or Inhibit to Q t_{PLH} , $t_{PHL} = (1.7 \text{ ns/pF}) C_L + 465 \text{ ns}$ t_{PLH} , $t_{PHL} = (0.66 \text{ ns/pF}) C_L + 197 \text{ ns}$ t_{PLH} , $t_{PHL} = (0.5 \text{ ns/pF}) C_L + 135 \text{ ns}$ Clock or Inhibit to "0" t_{PLH} , $t_{PHL} = (1.7 \text{ ns/pF}) C_L + 155 \text{ ns}$ t_{PLH} , $t_{PHL} = (0.66 \text{ ns/pF}) C_L + 87 \text{ ns}$ t_{PLH} , $t_{PHL} = (0.5 \text{ ns/pF}) C_L + 65 \text{ ns}$	t_{PLH} , t_{PHL} (Figures 4, 5, 6)	5.0 10 15	– – –	550 225 160	1100 450 320	ns
Propagation Delay Time Pn to Q	t_{PLH} , t_{PHL} (Figures 4, 7)	5.0 10 15	– – –	260 120 100	520 240 200	ns
Propagation Delay Time Reset to Q	t_{PHL} (Figure 8)	5.0 10 15	– – –	250 110 80	500 220 160	ns
Propagation Delay Time Preset Enable to "0"	t_{PHL} , t_{PLH} (Figures 4, 9)	5.0 10 15	– – –	220 100 80	440 200 160	ns
Clock or Inhibit Pulse Width	t_w (Figures 5, 6)	5.0 10 15	250 100 80	125 50 40	– – –	ns
Clock Pulse Frequency (with PE = low)	f_{max} (Figures 4, 5, 6)	5.0 10 15	– – –	2.0 5.0 6.6	1.5 3.0 4.0	MHz
Clock or Inhibit Rise and Fall Time	t_r , t_f (Figures 5, 6)	5.0 10 15	– – –	– – –	15 5 4	μs
Setup Time Pn to Preset Enable	t_{su} (Figure 1)	5.0 10 15	90 50 40	40 15 10	– – –	ns
Hold Time Preset Enable to Pn	t_h (Figure 2)	5.0 10 15	30 30 30	–15 –5 0	– – –	ns
Preset Enable Pulse Width	t_w (Figure 3)	5.0 10 15	250 100 80	125 50 40	– – –	ns
Reset Pulse Width	t_w (Figure 8)	5.0 10 15	350 250 200	175 125 100	– – –	ns
Reset Removal Time	t_{rem} (Figure 8)	5.0 10 15	10 20 30	–110 –30 –20	– – –	ns

5. The formulas given are for the typical characteristics only at 25 °C.

6. Data labelled "Typ" is not to be used for design purposes but is intended as an indication of the IC's potential performance.

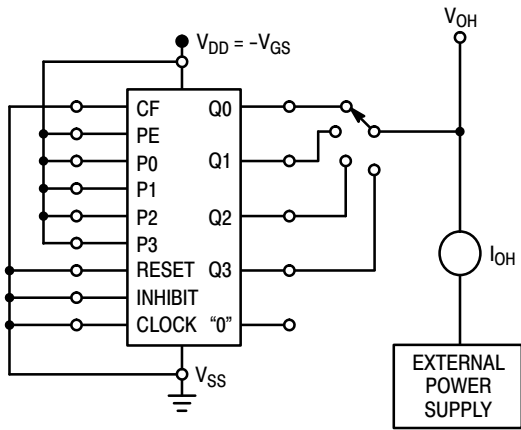

Figure 1. Typical Output Source Characteristics Test Circuit

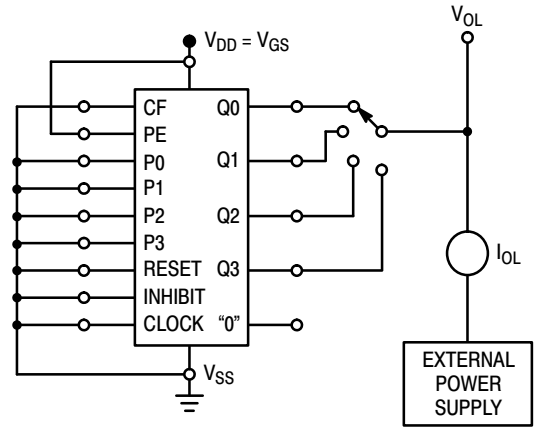

Figure 2. Typical Output Sink Characteristics Test Circuit

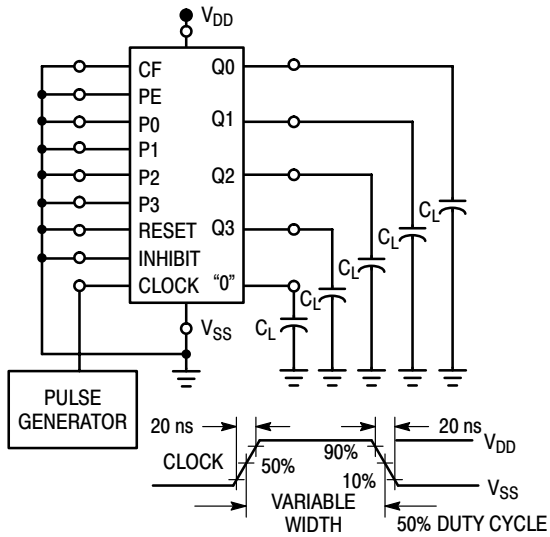
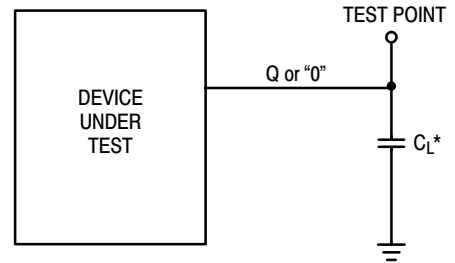

Figure 3. Power Dissipation



* Includes all probe and jig capacitance.

Figure 4. Test Circuit

SWITCHING WAVEFORMS

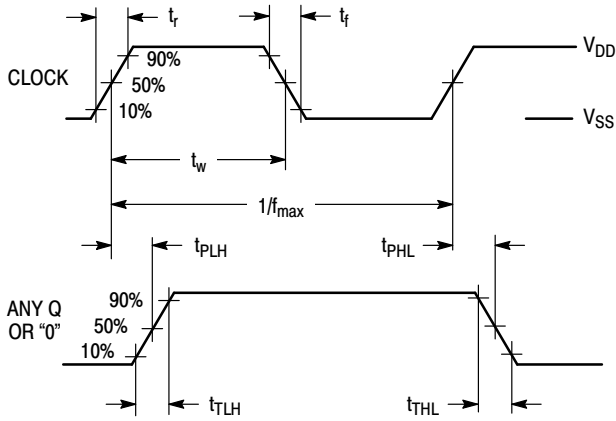

Figure 5.

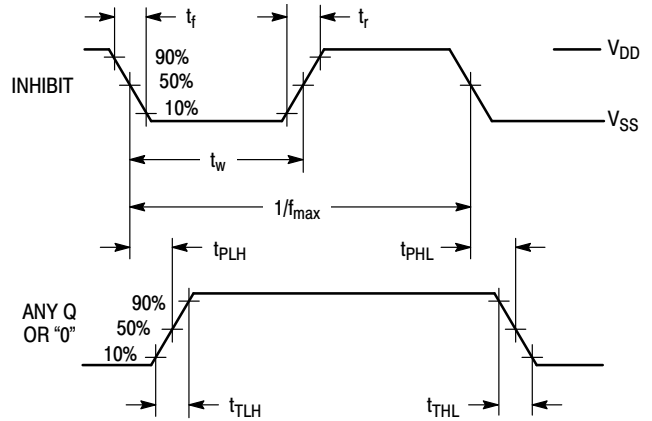

Figure 6.

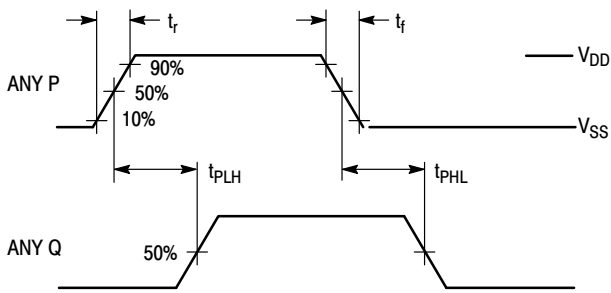

Figure 7.

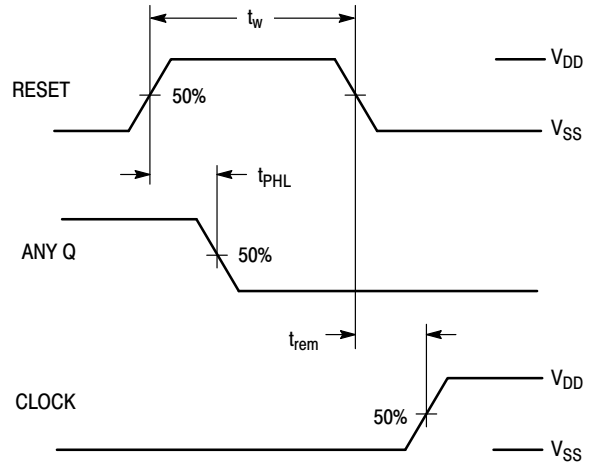

Figure 8.

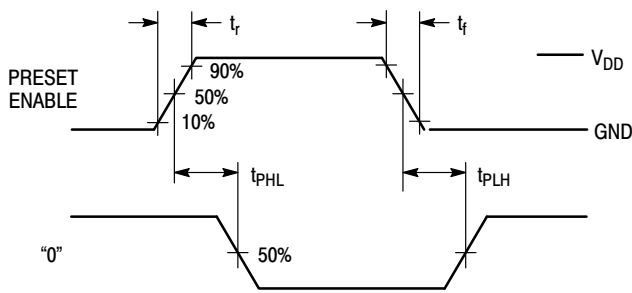

Figure 9.

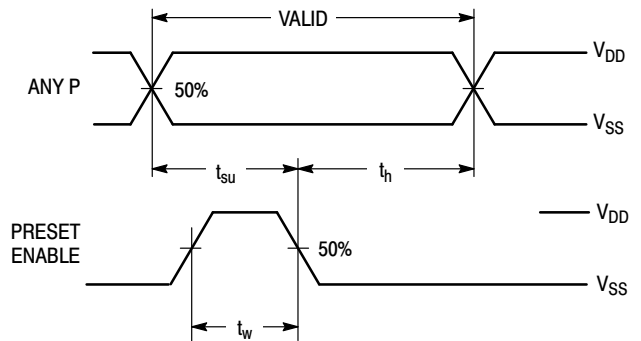

Figure 10.

MC14526B

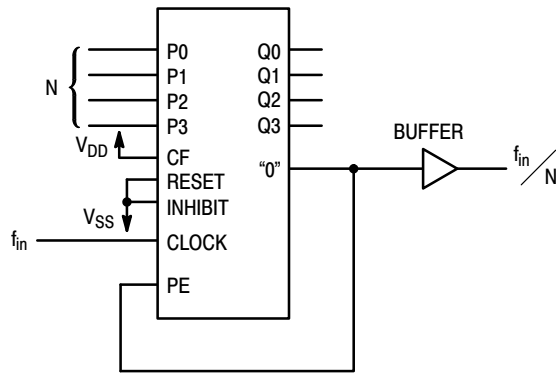

Figure 11. $\div N$ Counter

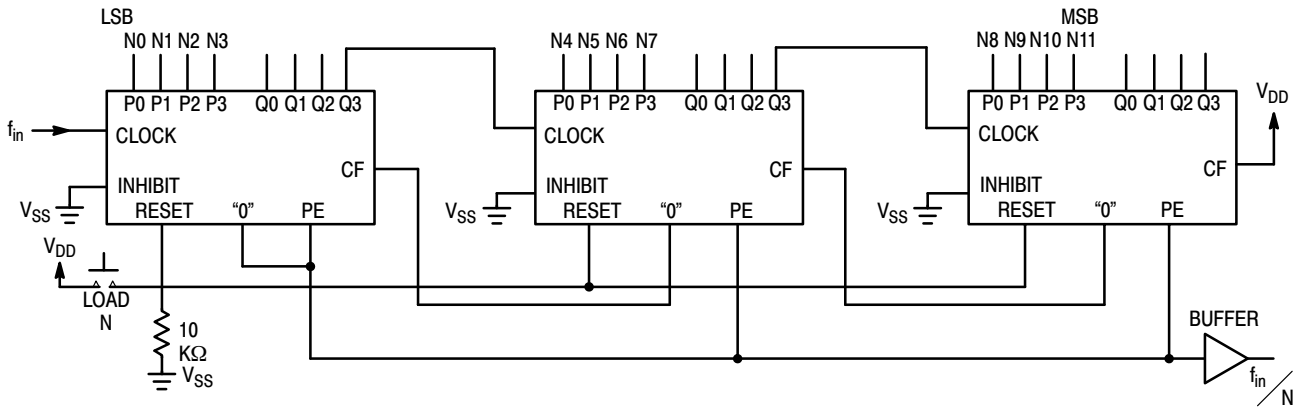

Figure 12. 3 Stages Cascaded

ORDERING INFORMATION

Device	Package	Shipping [†]
MC14526BDWG	SOIC-16 WB (Pb-Free)	47 Units / Rail
MC14526BDWR2G	SOIC-16 WB (Pb-Free)	1000 / Tape & Reel

[†] For information on tape and reel specifications, including part orientation and tape sizes, please refer to our Tape and Reel Packaging Specifications Brochure, [BRD8011/D](#).

MC14526B

REVISION HISTORY

Revision	Description of Changes	Date
9	Rebranded the Data Sheet to onsemi format.	10/3/2025

This document has undergone updates prior to the inclusion of this revision history table. The changes tracked here only reflect updates made on the noted approval dates.

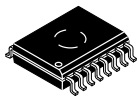

1
SCALE 1:1

SOIC-16 WB
CASE 751G
ISSUE E

DATE 08 OCT 2021

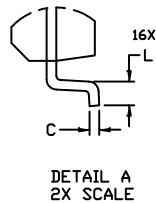
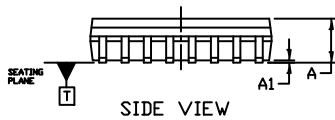
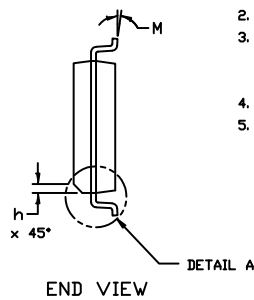
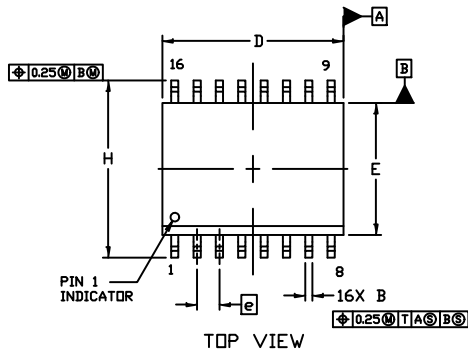

NOTES:

- DIMENSIONING AND TOLERANCING PER ASME Y14.5M, 1994.
- CONTROLLING DIMENSION: MILLIMETERS
- DIMENSION b DOES NOT INCLUDE DAMBAR PROTRUSION. ALLOWABLE PROTRUSION SHALL BE 0.13 TOTAL IN EXCESS OF B DIMENSION AT MAXIMUM MATERIAL CONDITION.
- DIMENSIONS D AND E DO NOT INCLUDE MOLD PROTRUSIONS.
- MAXIMUM MOLD PROTRUSION OR FLASH TO BE 0.15 PER SIDE.

DIM	MILLIMETERS	
	MIN.	MAX.
A	2.35	2.65
A1	0.10	0.25
B	0.35	0.49
C	0.23	0.32
D	10.15	10.45
E	7.40	7.60
e	1.27 BSC	
H	10.05	10.55
h	0.53 REF	
L	0.50	0.90
M	0°	7°

GENERIC
MARKING DIAGRAM*

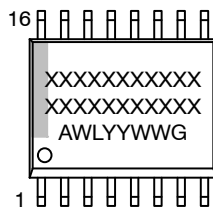

- XXXXXX = Specific Device Code
- A = Assembly Location
- WL = Wafer Lot
- YY = Year
- WW = Work Week
- G = Pb-Free Package

*This information is generic. Please refer to device data sheet for actual part marking. Pb-Free indicator, "G" or microdot "•", may or may not be present. Some products may not follow the Generic Marking.

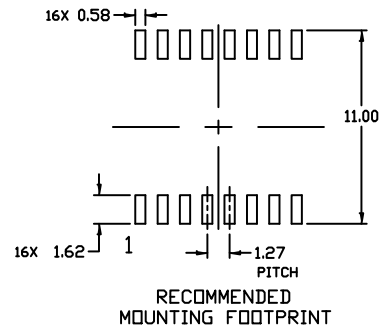

DOCUMENT NUMBER:	98ASB42567B	Electronic versions are uncontrolled except when accessed directly from the Document Repository. Printed versions are uncontrolled except when stamped "CONTROLLED COPY" in red.
DESCRIPTION:	SOIC-16 WB	PAGE 1 OF 1

onsemi and onSEMI are trademarks of Semiconductor Components Industries, LLC dba onsemi or its subsidiaries in the United States and/or other countries. onsemi reserves the right to make changes without further notice to any products herein. onsemi makes no warranty, representation or guarantee regarding the suitability of its products for any particular purpose, nor does onsemi assume any liability arising out of the application or use of any product or circuit, and specifically disclaims any and all liability, including without limitation special, consequential or incidental damages. onsemi does not convey any license under its patent rights nor the rights of others.

onsemi, **Onsemi**, and other names, marks, and brands are registered and/or common law trademarks of Semiconductor Components Industries, LLC dba "**onsemi**" or its affiliates and/or subsidiaries in the United States and/or other countries. **onsemi** owns the rights to a number of patents, trademarks, copyrights, trade secrets, and other intellectual property. A listing of **onsemi**'s product/patent coverage may be accessed at www.onsemi.com/site/pdf/Patent-Marking.pdf. **onsemi** reserves the right to make changes at any time to any products or information herein, without notice. The information herein is provided "as-is" and **onsemi** makes no warranty, representation or guarantee regarding the accuracy of the information, product features, availability, functionality, or suitability of its products for any particular purpose, nor does **onsemi** assume any liability arising out of the application or use of any product or circuit, and specifically disclaims any and all liability, including without limitation special, consequential or incidental damages. Buyer is responsible for its products and applications using **onsemi** products, including compliance with all laws, regulations and safety requirements or standards, regardless of any support or applications information provided by **onsemi**. "Typical" parameters which may be provided in **onsemi** data sheets and/or specifications can and do vary in different applications and actual performance may vary over time. All operating parameters, including "Typicals" must be validated for each customer application by customer's technical experts. **onsemi** does not convey any license under any of its intellectual property rights nor the rights of others. **onsemi** products are not designed, intended, or authorized for use as a critical component in life support systems or any FDA Class 3 medical devices or medical devices with a same or similar classification in a foreign jurisdiction or any devices intended for implantation in the human body. Should Buyer purchase or use **onsemi** products for any such unintended or unauthorized application, Buyer shall indemnify and hold **onsemi** and its officers, employees, subsidiaries, affiliates, and distributors harmless against all claims, costs, damages, and expenses, and reasonable attorney fees arising out of, directly or indirectly, any claim of personal injury or death associated with such unintended or unauthorized use, even if such claim alleges that **onsemi** was negligent regarding the design or manufacture of the part. **onsemi** is an Equal Opportunity/Affirmative Action Employer. This literature is subject to all applicable copyright laws and is not for resale in any manner.

ADDITIONAL INFORMATION

TECHNICAL PUBLICATIONS:

Technical Library: www.onsemi.com/design/resources/technical-documentation
onsemi Website: www.onsemi.com

ONLINE SUPPORT: www.onsemi.com/support

For additional information, please contact your local Sales Representative at www.onsemi.com/support/sales

Looking for pricing, stock, or lifecycle information?

Click below to explore more details on WIN SOURCE:

 [View MC14526BDWG](#) on WIN SOURCE

 [ON Semiconductor](#) Information

Optimize Your Supply Chain with WIN SOURCE Solutions

-  Global Sourcing Solution
-  Obsolete Management
-  Cost Control Management
-  Shortage Management
-  Alternative Solution
-  Excess Inventory Management