

Description

The Abracon AMJM series is a programmable MEMS oscillator, offering four different package size configurations (1612mm, 2016mm, 2520mm, and 3225mm). All packages are capable of operating with a supply range of 1.71V to 3.63V. This series features low power consumption, a wide frequency range, tight stabilities, and short lead times for industrial, consumer, and other applications.

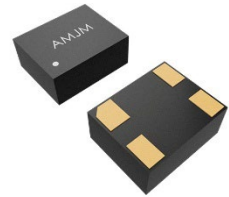

Features

- Compact footprint as small as 1.6x1.2mm
- Low power consumption, 3.0mA IDD (typ at Fo=27MHz)
- 1MHz to 100MHz output frequency range
- Output Drive Options: Standard or High
- Wide -40°C to 85°C operating temperature range
- Output Enable or Standby Function
- [REACH/RoHS II Compliant | MSL Level 1](#)

Typical Applications

- Storage Area Networks (SATA, SAS, Fiber Channel)
- Passive Optical Networks (EPON, 10G-EPON, GPON, 10G-PON)
- Ethernet (1G, 10GBASE-T, /KR/LR/SR, FCoE)
- PCI Express
- Display port

Electrical Specifications

Electrical characteristics unless otherwise indicated, VDD = 1.8V -5% to 3.3V +10%, temperature range -40°C to 85 °C

Parameters		Min.	Typ.	Max.	Units	Notes
Frequency Range (F)		1.0000		100.0000	MHz	
Power Supply Voltage (V _{DD})		1.71		3.63	V	
Current Consumption (I _{DD})			3.0		mA	f _{out} = 27MHz, V _{DD} = 1.8V, No load
Standby Current Consumption (I _{STBY}) [Note 1]			1		μA	V _{DD} = 1.8V/2.5V
			1.5			V _{DD} = 3.3V
Operating Temperature Range (T _{USE})		-40		+85	°C	See Options
Storage Temperature		-55		+150	°C	
All Inclusive Frequency Stability [Note 2]		-25		+25	ppm	Options "D" or "F"
		-50		+50		Options "E" or "G"
Aging		-5		±5	ppm	1 st year @25°C
		-1		±1		Per year after first year
Duty Cycle		45		55	%	
Output Logic Levels		V _{OH}	0.8*V _{DD}		V	Std Drive option: I = 3mA
		V _{OL}		0.2*V _{DD}		High Drive option: I = 6mA
Input Logic Levels [Note 3]		V _{IH}	0.7*V _{DD}		V	Std Drive option: I = -3mA
		V _{IL}		0.3*V _{DD}		High Drive option: I = -6mA
Enable Pull-Up Resistor [Note 5]			300		kΩ	From 90% V _{DD} to valid clock output, @ 25°C
Power Supply Ramp (t _{PU}) [Note 6]		0.1		100	ms	Time to 90% targeted V _{DD}
Start-up Time (t _{SU})				1.5	ms	

Electrical Specifications *continued*

Parameters		Min.	Typ.	Max.	Units	Notes
Output Enable Time (t_{EN}) [Note 4]	OE			1	μ s	
	Standby			1.5	ms	
Output Disable Time (t_{DA})				200+2 periods	ns	
Rise (T_r) / Fall (T_f) Time	High Drive 20% \leftrightarrow 80%		1	1.5	ns	CL = 15pF VDD = 1.8V
			0.5	1.0		CL = 15 pF V _{DD} = 2.5 V/3.3 V
	Std Drive 20% \leftrightarrow 80%		1.2	2.0		CL = 10pF VDD = 1.8V
			0.6	1.2		CL = 10 pF V _{DD} = 2.5 V/3.3 V
RMS Period Jitter (J_{PER})	$F_{out} = 27\text{MHz}$		8.5	11	ps	V _{DD} = 1.8V
			7	9		V _{DD} = 2.5V/3.3V
Cycle-to-Cycle Jitter (Peak) (J_{Cy-Cy})	$F_{out} = 27\text{MHz}$		50	70	ps	V _{DD} = 1.8V
			35	60		V _{DD} 2.5V/3.3V
Peak to Peak Period Jitter (J_{Cy-Cy}) [Note 7]	$F_{out} = 27\text{MHz}$		70		ps	V _{DD} = 1.8V
			60			V _{DD} 2.5V/3.3V

Note 1: Not including current through pull-up resistor on EN pin (if configured). Higher standby current seen at >3.3V VDD.

Note 2: Includes post reflow frequency accuracy, temperature stability, load pulling and power supply variation.

Note 3: Input waveform must be monotonic with rise/fall time <10 ms.

Note 4: For parts configured with OE, not Standby.

Note 5: Output is enabled if pad is floated or not connected.

Note 6: Time to reach 90% of target VDD. Power ramp rise must be monotonic

Note 7: Peak to peak period jitter is measured over 10,000 cycles.

Absolute Maximum Ratings

Parameters	Min.	Typ.	Max.	Units	Notes
Supply Voltage	-0.3		+4.0	V	
Input Voltage	-0.3		V _{DD} +0.3	V	
Maximum Junction Temperature			+150	°C	
Ambient Operating Temperature	-40		+85	°C	Industrial
Ambient Operating Temperature	-20		+70	°C	Extended Commercial
Storage Ambient Temperature Range	-55		+150	°C	
Soldering Temperature		+260		°C	
ESD Protection	4kV HBM, 400V MM, 2kV CDM				

Options and Part Identification

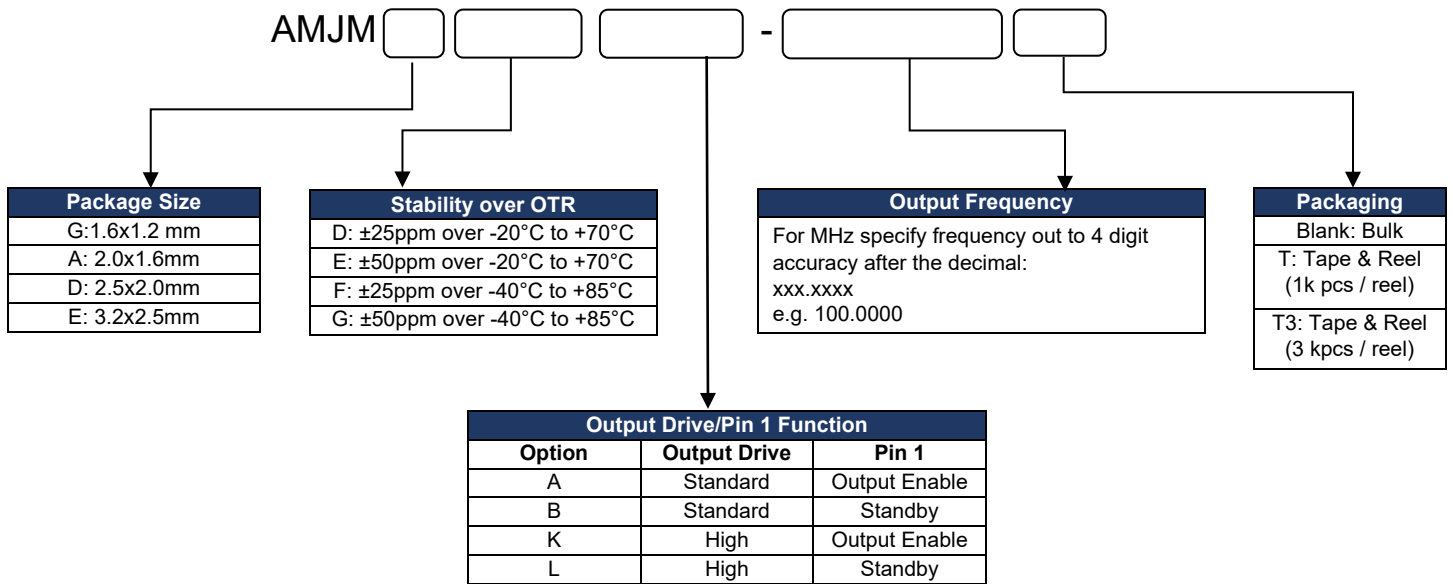

Part Number Example:

AMJMGK-8.0000T

Typical Performance Data @ 25°C ± 3°C

Current Consumption vs Frequency

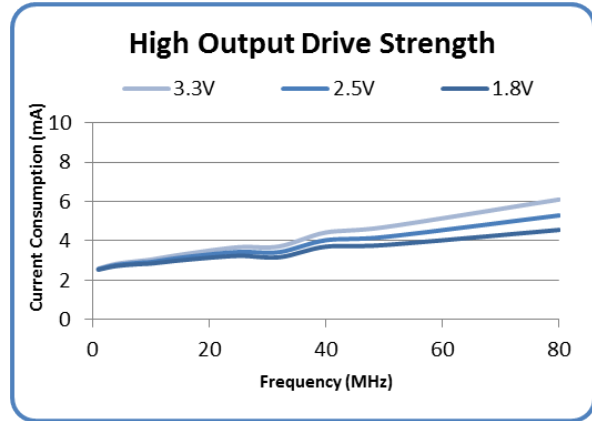
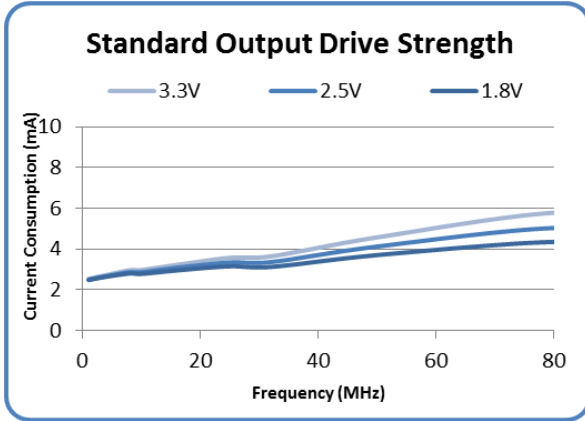

Current Consumption vs Supply Voltage

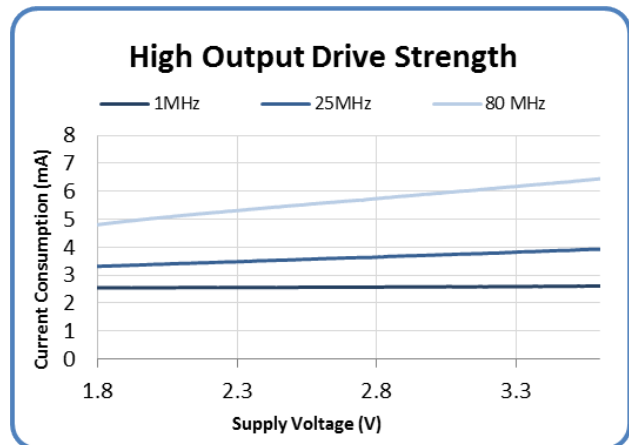
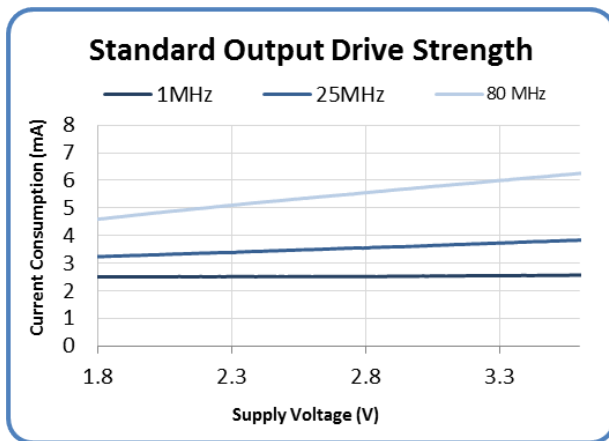

Pin Functions

Pin	Pin Name	Description
1	OE	Output Enable ^{Note 1&3} : High or Open = Specified Frequency Output Low = Output is high impedance
	STBY	Standby ^{Note 1&3} : High or Open = Specified Frequency Output Low = Output is high impedance, Device is in low power mode, Supply current is ISTBY
2	GND	Power Supply Ground
3	Output	Oscillator clock output
4	V _{DD}	Power supply ^{Note 2}

Note 8. If pin 1 is high or floating, there will be frequency output. If pin 1 is low, output will be disengaged.

Note 9. Bypass with 0.1 μ F capacitor placed as close to VDD pin as possible.

Note 10. 300 K Ω internal pull-up resistor present on pin 1.

Diagrams

Output Waveform

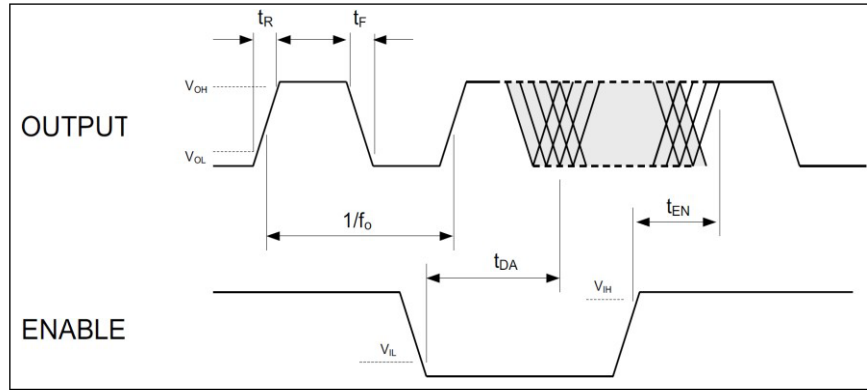

Test Circuit

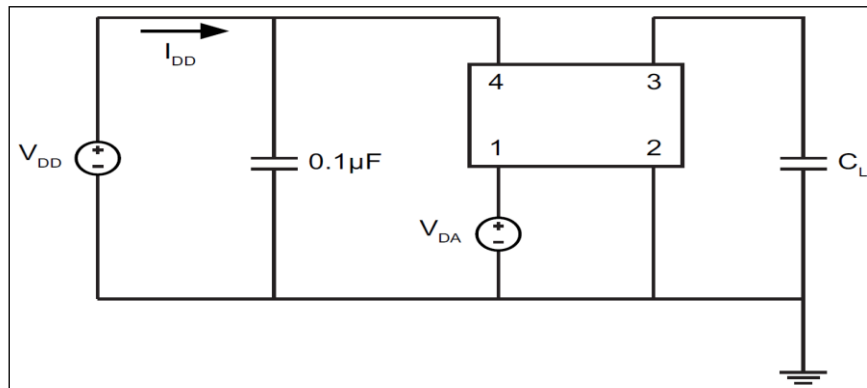

Recommended Board Layout

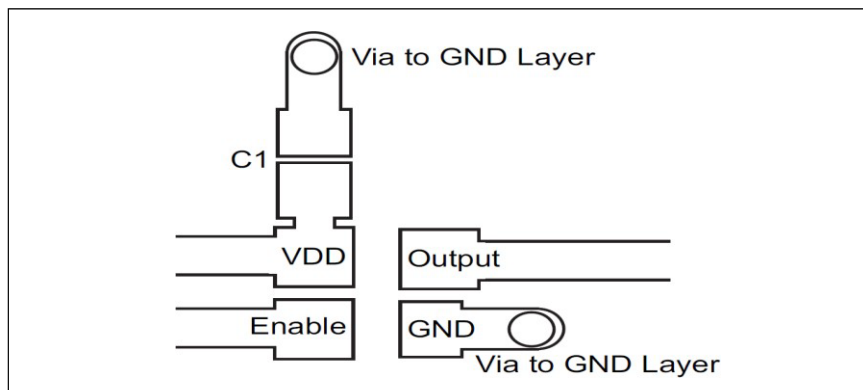

Mechanical Dimensions

1.6 x 1.2 mm VFLGA Package Outline

Top View

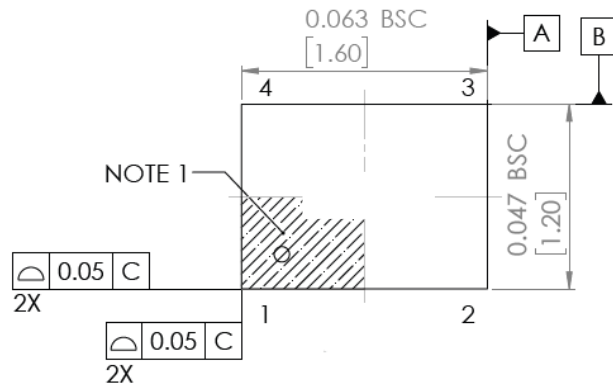

Side View

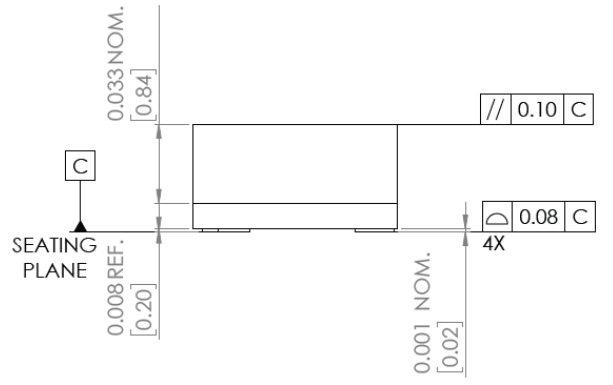

Bottom View

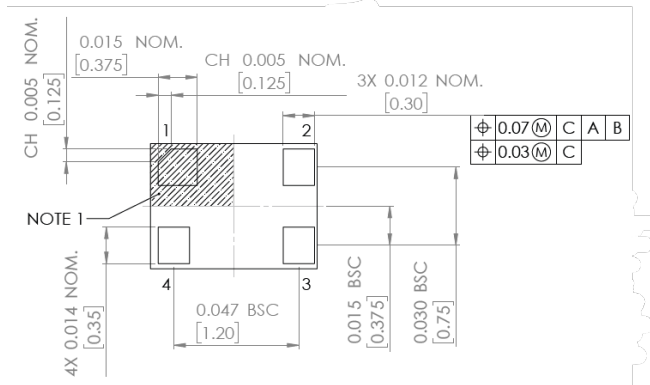

Recommended Landing Pattern

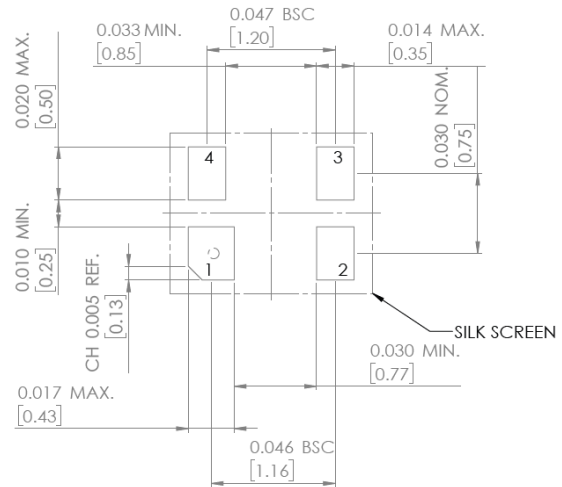

* Standoff max .05 mm and min 0.00 mm

Dimensioning and tolerance per ASME Y14.5M
 BSC: Basic Dimension. Theoretically exact value shown without tolerances
 REF: Reference Dimension, usually without tolerance, for information purposes only

Dimensions: Inches[mm]

2.0 x 1.6 mm VFLGA Package Outline

Top View

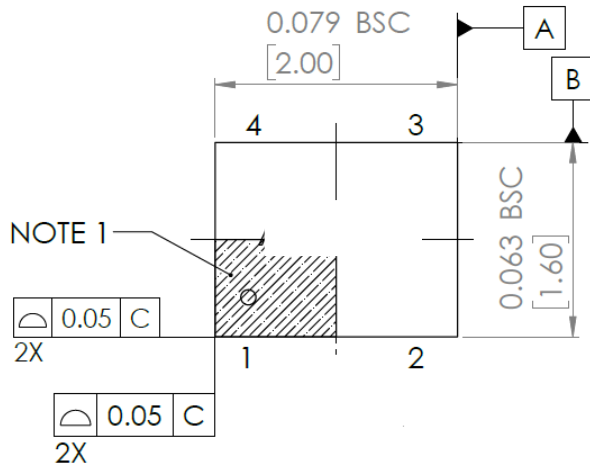

Side View

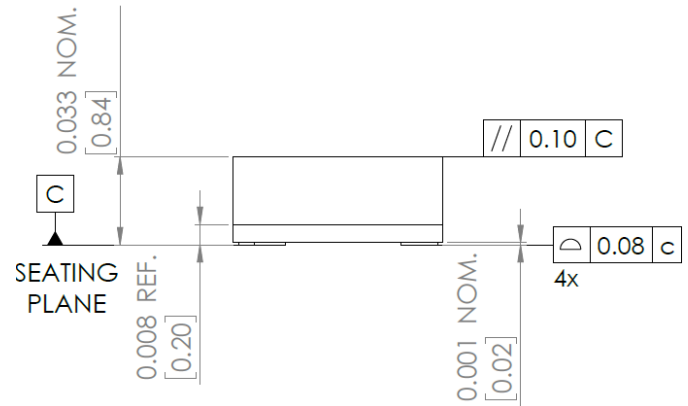

Bottom View

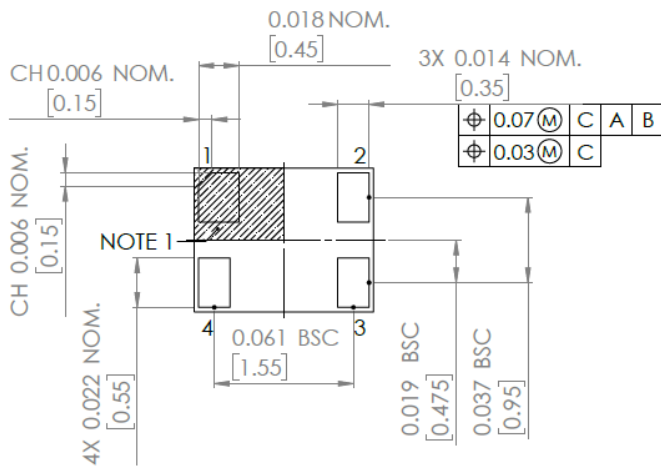

Recommended Landing Pattern

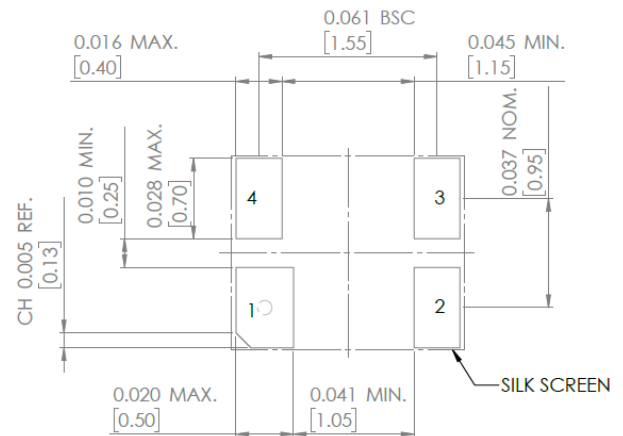

*Standoff max .05 mm and min 0.00 mm

Dimensioning and tolerance per ASME Y14.5M

BSC: Basic Dimension. Theoretically exact value shown without tolerances

REF: Reference Dimension, usually without tolerance, for information purposes only

Dimensions: Inches[mm]

2.5 x 2.0 mm VLGA Package Outline

Top View

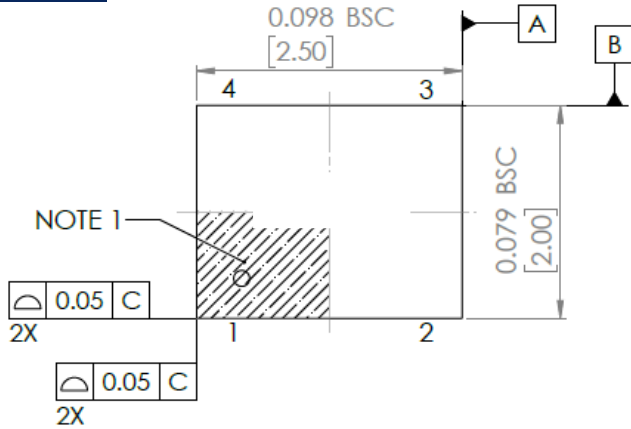

Side View

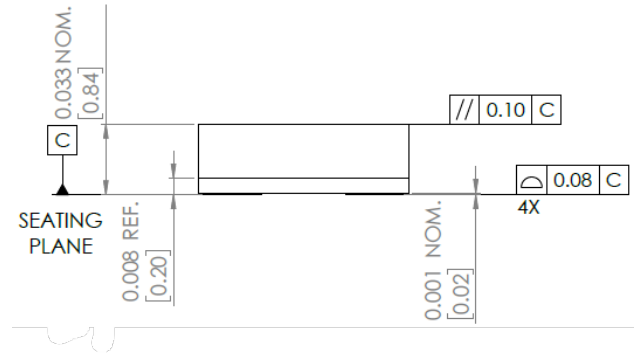

Bottom View

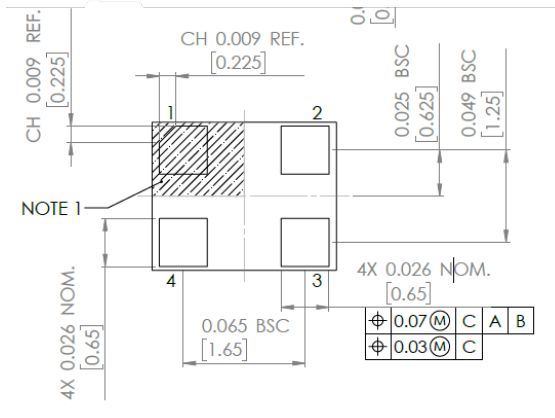

Recommended Land Pattern

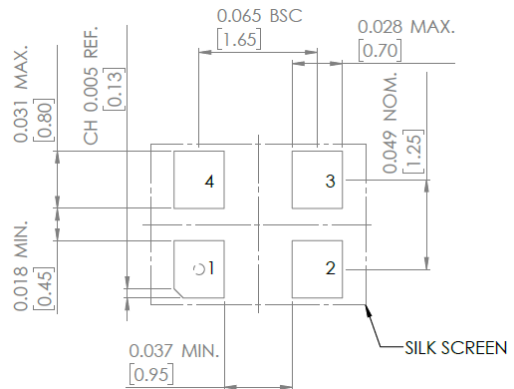

*Standoff max .05 mm and min 0.00 mm

Dimensioning and tolerance per ASME Y14.5M

BSC: Basic Dimension. Theoretically exact value shown without tolerances

REF: Reference Dimension, usually without tolerance, for information purposes only

Dimensions: Inches[mm]

3.5 x 2.5 mm DFN Package Outline

Top View

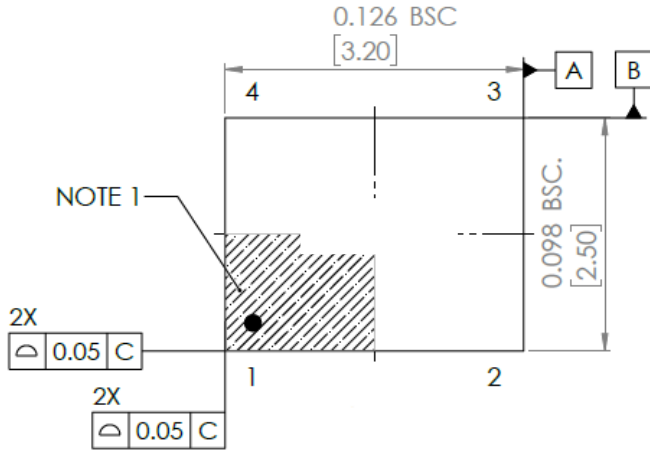

Side View

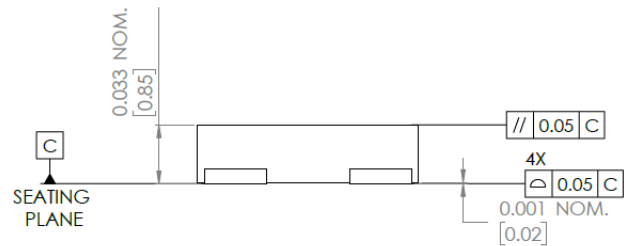

Bottom View

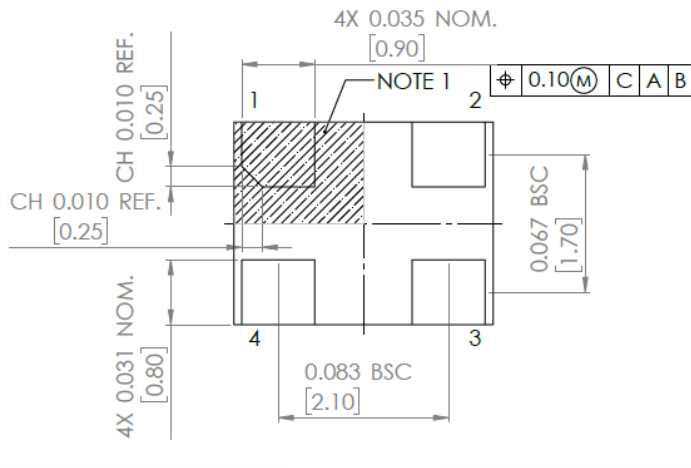

Recommended Land Pattern

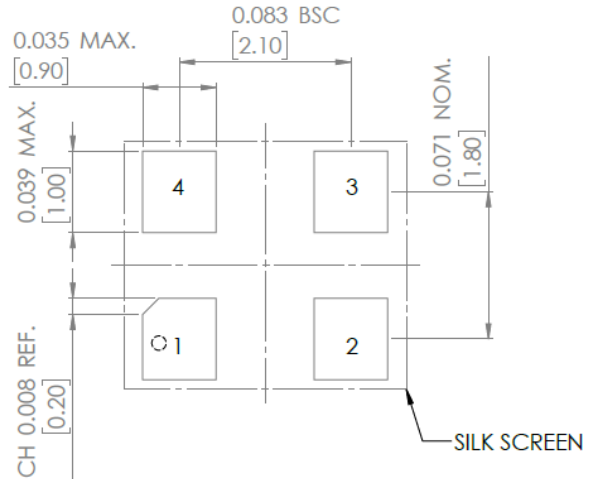

*Standoff max .05 mm and min 0.00 mm

Dimensioning and tolerance per ASME Y14.5M
BSC: Basic Dimension. Theoretically exact value shown without tolerances
REF: Reference Dimension, usually without tolerance, for information purposes only

Dimensions: Inches[mm]

Reflow Profile [JEDEC J-STD-020]

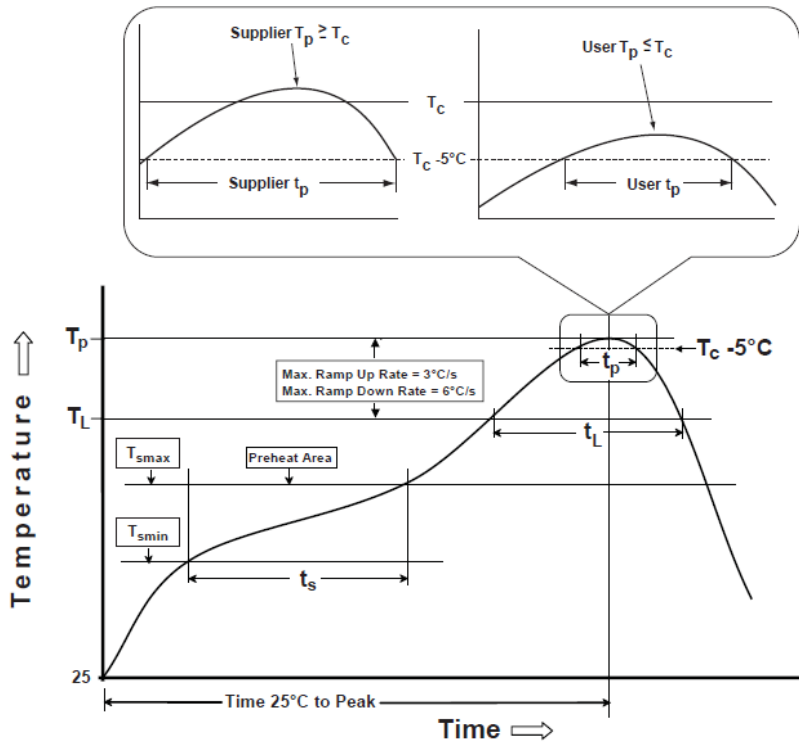

Table 1

SnPb Eutectic Process Classification Temperatures (T _c)		
Package Thickness	Volume mm ³ <350	Volume mm ³ ≥350
<2.5 mm	235 °C	220 °C
≥2.5 mm	220 °C	220 °C

Table 2

Pb-Free Process Classification Temperatures (T _c)			
Package Thickness	Volume mm ³ <350	Volume mm ³ 350-2000	Volume mm ³ >2000
<1.6 mm	260 °C	260 °C	260 °C
1.6 mm - 2.5 mm	260 °C	250 °C	245 °C
>2.5 mm	250 °C	245 °C	245 °C

Profile Feature	Sn-Pb Eutectic Assembly	Pb-Free Assembly
Preheat / soak		
Temperature minimum (T _{smin})	100°C	150°C
Temperature maximum (T _{smax})	150°C	200°C
Time (T _{smin} to T _{smax}) (t _s)	60 - 120 sec.	60 - 120 sec.
Average ramp-up rate (T _{smax} to T _p)	3°C/sec. max	3°C/sec. max
Liquidous temperature (T _L)	183°C	217°C
Time at liquidous (t _L)	60 - 150 sec.	60 - 150 sec.
Peak package body temperature (T _p)*	see Table 1	see Table 2
Time (t _p)** within 5°C of the specified classification temperature (T _c)	20 sec.	30 sec.
Ramp-down rate (T _p to T _{smax})	6°C/sec. max	6°C/sec. max
Time 25°C to peak temperature	6 min. max	8 min. max
Reflow cycles	2 max	2 max

*Tolerance for peak profile temperature (T_p) is defined as a supplier minimum and a user maximum.

**Tolerance for time at peak profile temperature (t_p) is defined as supplier minimum and a user maximum.

Packaging

1.6 mm x 1.2 mm VFLGA

T=1,000pcs/reel

T3=3,000pcs/reel

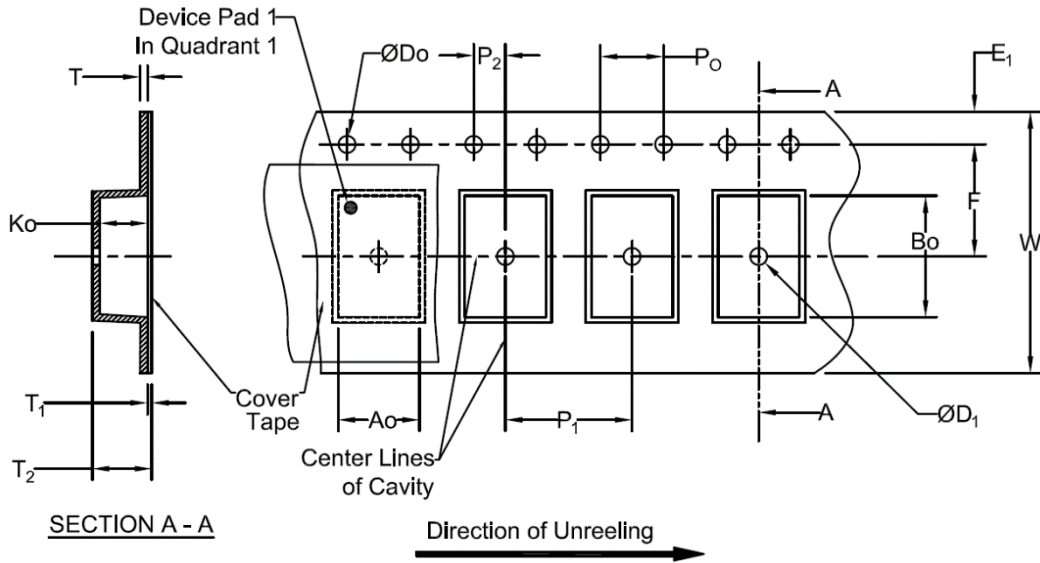

Tape Specifications (mm)							
Width	Ao	Bo	Do	D ₁ (Min)	E ₁	F	Ko
8mm	*	*	1.5+0.1/-0.0	1.0	1.75±0.1	3.5±0.05	*
Width	P1	P2	P0	T (Max)	T1 (Max)	T2 (Max)	W (Max)
8mm	4.0±0.1	2.0±0.05	4.0±0.1	0.6	0.1	2.5	8.3

***Note: Compliant to EIA-481**

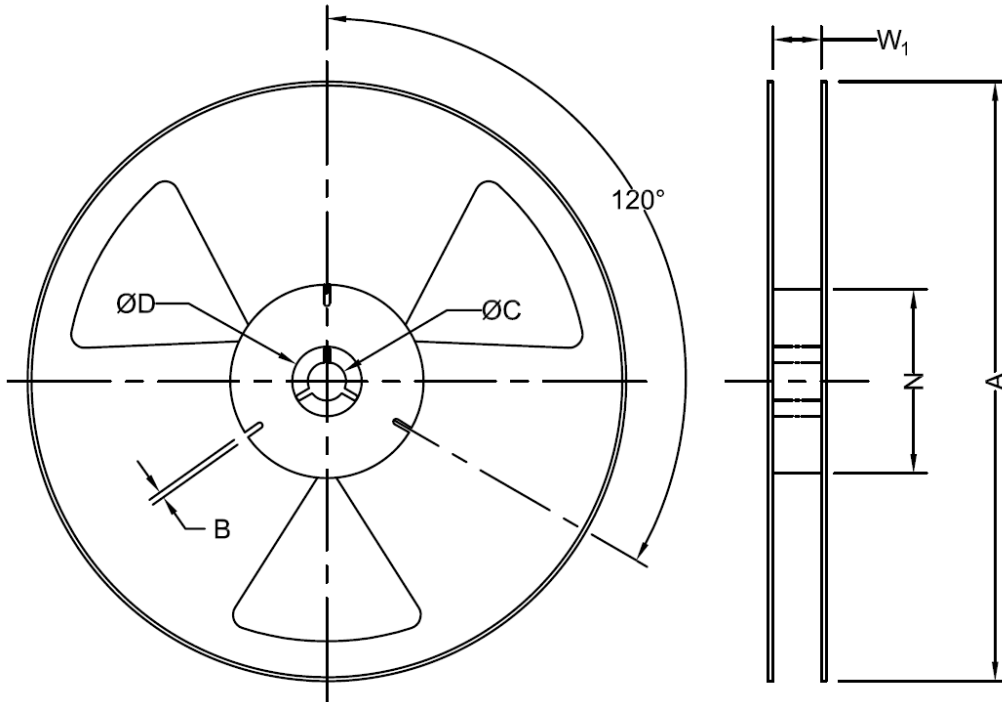

Reel Specifications (mm)							
Width	Qty/Reel	A (Nom)	B (Min)	C (Min)	D (Min)	N (Min)	*W ₁
8mm	1000	178	1.5	13.0+0.5/-0.2	20.2	50	8.4+1.5/-0.0
	3000	178	1.5	13.0+0.5/-0.2	20.2	50	8.4+1.5/-0.0

***Note: Measured at Hub**

2.0 mm x 1.6 mm VFLGA

T=1,000pcs/reel

T3=3,000pcs/reel

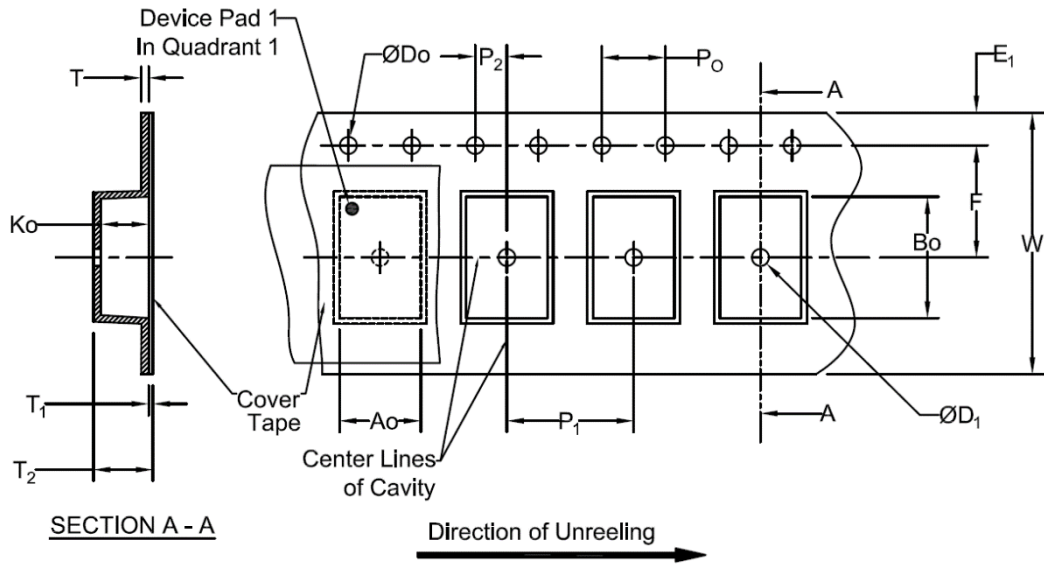

Tape Specifications (mm)							
Width	Ao	Bo	Do	D ₁ (Min)	E ₁	F	Ko
8mm	*	*	1.5+0.1/-0.0	1.0	1.75±0.1	3.5±0.05	*
Width	P1	P2	P0	T (Max)	T1 (Max)	T2 (Max)	W (Max)
8mm	4.0±0.1	2.0±0.05	4.0±0.1	0.6	0.1	2.5	8.3

*Note: Compliant to EIA-481

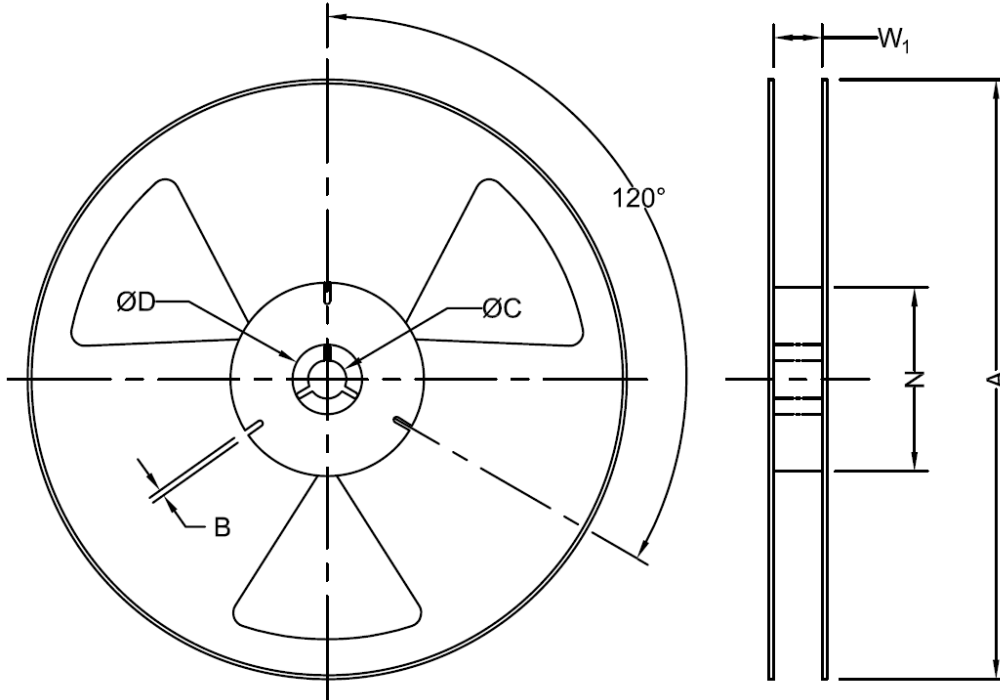

Reel Specifications (mm)							
Width	Qty/Reel	A (Nom)	B (Min)	C (Min)	D (Min)	N (Min)	*W ₁
8mm	1000	178	1.5	13.0+0.5/-0.2	20.2	50	8.4+1.5/-0.0
	3000	178	1.5	13.0+0.5/-0.2	20.2	50	8.4+1.5/-0.0

***Note: Measured at Hub**

2.5 mm x 2.0 mm VLGA

T= 1,000pcs/reel

T3= 3,000pcs/reel

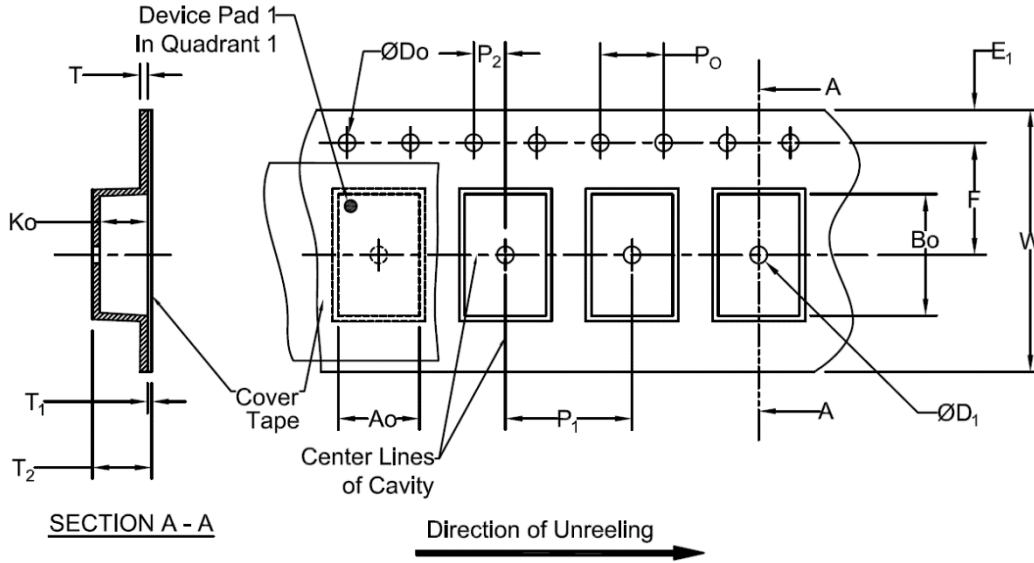

Tape Specifications (mm)							
Width	Ao	Bo	Do	D ₁ (Min)	E ₁	F	Ko
8mm	*	*	1.5+0.1/-0.0	1.0	1.75±0.1	3.5±0.05	*
Width	P ₁	P ₂	P ₀	T (Max)	T ₁ (Max)	T ₂ (Max)	W (Max)
8mm	4.0±0.1	2.0±0.05	4.0±0.1	0.6	0.1	2.5	8.3

***Note: Compliant to EIA-481**

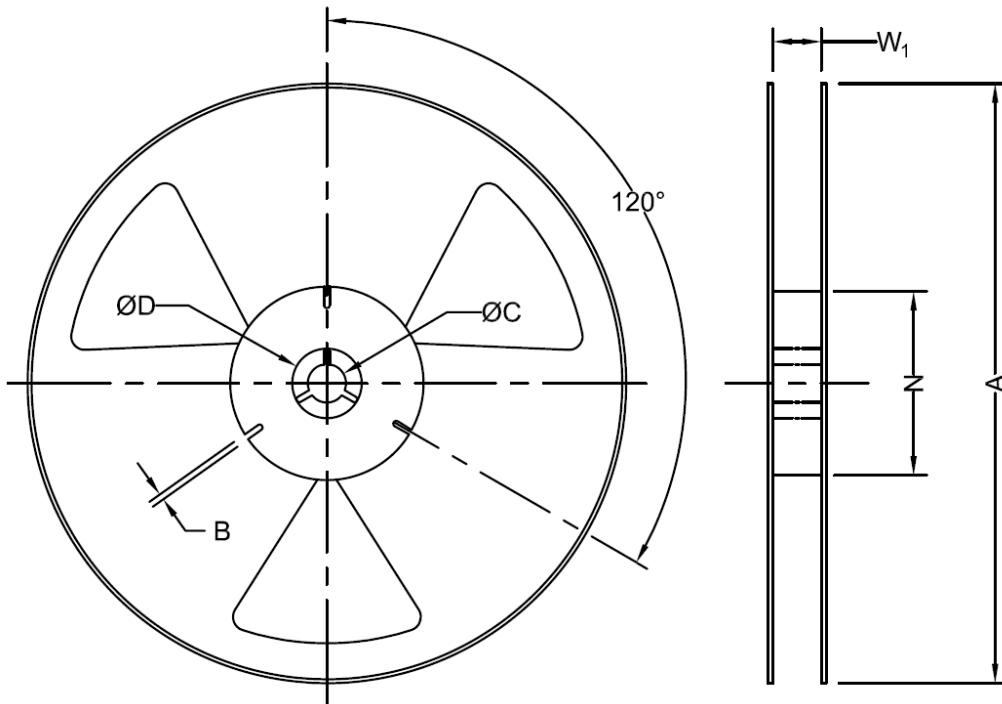

Reel Specifications (mm)							
Width	Qty/Reel	A (Nom)	B (Min)	C (Min)	D (Min)	N (Min)	*W ₁
8mm	1000	178	1.5	13.0+0.5/-0.2	20.2	50	8.4+1.5/-0.0
	3000	178	1.5	13.0+0.5/-0.2	20.2	50	8.4+1.5/-0.0

***Note: Measured at Hub**

3.2 mm x 5.0 mm DFN

T= 1,000pcs/reel

T3= 3,000pcs/reel

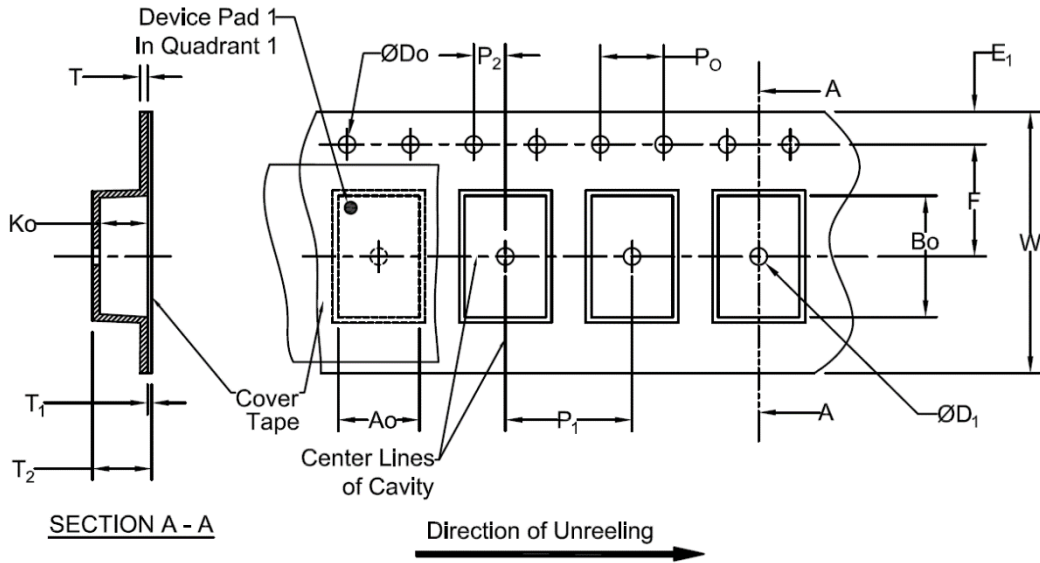

Tape Specifications (mm)							
Width	Ao	Bo	Do	D ₁ (Min)	E ₁	F	Ko
12mm	*	*	1.5+0.1/-0.0	1.0	1.75±0.1	5.5±0.05	*
Width	P1	P2	P0	T (Max)	T1 (Max)	T2 (Max)	W (Max)
12mm	4.0±0.1	2.0±0.05	4.0±0.1	0.6	0.1	6.5	12.3

***Note: Compliant to EIA-481**

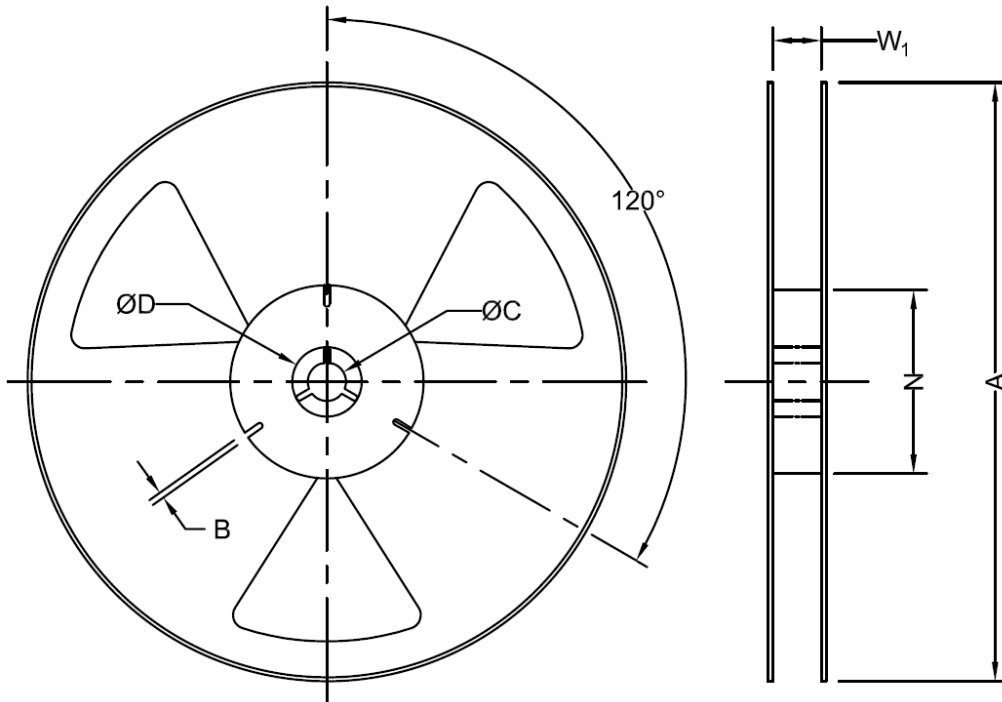

Reel Specifications (mm)							
Width	Qty/Reel	A (Nom)	B (Min)	C (Min)	D (Min)	N (Min)	*W ₁
12mm	1000	178	1.5	13.0+0.5/-0.2	20.2	50	12.4+2.0/-0.0
12mm	3000	178	1.5	13.0+0.5/-0.2	20.2	50	12.4+2.0/-0.0

*Note: Measured at Hub

Looking for pricing, stock, or lifecycle information?

Click below to explore more details on WIN SOURCE:

⊖ [View AMJMDFB-100.0000T on WIN SOURCE](#)

⊖ [Abracon LLC Information](#)

Optimize Your Supply Chain with WIN SOURCE Solutions

- ✓ Global Sourcing Solution
- ✓ Obsolete Management
- ✓ Cost Control Management
- ✓ Shortage Management
- ✓ Alternative Solution
- ✓ Excess Inventory Management