



**THE DATASHEET OF
CY9BF306NBPMC-G-UNE1**





Please note that Cypress is an Infineon Technologies Company.

The document following this cover page is marked as “Cypress” document as this is the company that originally developed the product. Please note that Infineon will continue to offer the product to new and existing customers as part of the Infineon product portfolio.

Continuity of document content

The fact that Infineon offers the following product as part of the Infineon product portfolio does not lead to any changes to this document. Future revisions will occur when appropriate, and any changes will be set out on the document history page.

Continuity of ordering part numbers

Infineon continues to support existing part numbers. Please continue to use the ordering part numbers listed in the datasheet for ordering.



The CY9B300B Series are a highly integrated 32-bit microcontroller that target for high-performance and cost-sensitive embedded control applications.

The CY9B300B Series are based on the Arm® Cortex®-M3 Processor and on-chip Flash memory and SRAM, and peripheral functions, including Motor Control Timers, ADCs and Communication Interfaces (USB, UART, CSIO, I²C, LIN).

The products which are described in this datasheet are placed into TYPE0 product categories in FM3 Family Peripheral Manual.

Features

32-bit Arm® Cortex®-M3 Core

- Processor version: r2p0
- Up to 80 MHz Frequency Operation
- Memory Protection Unit (MPU): improve the reliability of an embedded system
- Integrated Nested Vectored Interrupt Controller (NVIC): 1 NMI (non-maskable interrupt) and 48 peripheral interrupts and 16 priority levels
- 24-bit System timer (Sys Tick): System timer for OS task management

On-chip Memories

[Flash memory]

- Up to 512 KB
- Read cycle: 0 wait-cycle @ up to 60 MHz, 2 wait-cycle^[1] above
 - [1]: Instruction pre-fetch buffer is included. So when CPU access continuously, it becomes 0 wait-cycle
- Security function for code protection

[SRAM]

This series contain a total of up to 64 KB on-chip SRAM. This is composed of two independent SRAM (SRAM0, SRAM1). SRAM0 is connected to I-code bus and D-code bus of Cortex-M3 core. SRAM1 is connected to System bus.

- SRAM0: Up to 32 KB
- SRAM1: Up to 32 KB

USB Interface

The USB interface is composed of Device and Host. PLL for USB is built-in, USB clock can be generated by multiplication of Main clock.

[USB Device]

- USB2.0 Full-Speed supported
- Max 6 EndPoint supported
 - EndPoint 0 is control transfer
 - EndPoint 1 - 5 can be selected bulk-transfer or interrupt-transfer
 - Endpoint1-5 is comprised Double Buffers.

[USB host]

- USB2.0 Full/Low-speed supported
- Bulk-transfer and interrupt-transfer and Isochronous-transfer support
- USB Device connected/dis-connected automatically detect
- IN/OUT token handshake packet automatically
- Max 256-byte packet-length supported
- Wake-up function supported

Multi-function Serial Interface (Max. 8 channels)

- 4 channels with 16steps × 9bit FIFO (ch.4-ch.7), 4 channels without FIFO (ch.0-ch.3)
- Operation mode is selectable from the followings for each channel.
 - UART
 - CSIO
 - LIN
 - I²C

[UART]

- Full-duplex double buffer
- Selection with or without parity supported
- Built-in dedicated baud rate generator
- External clock available as a serial clock
- Hardware Flow control: Automatically control the transmission by CTS/RTS (only ch.4)
- Various error detect functions available (parity errors, framing errors, and overrun errors)

[CSIO]

- Full-duplex double buffer
- Built-in dedicated baud rate generator
- Overrun error detect function available

[LIN]

- LIN protocol Rev.2.1 supported
- Full duplex double buffer
- Master/Slave mode supported
- LIN break field generate (can be changed 13-16 bit length)
- LIN break delimiter generate (can be changed 1-4 bit length)
- Various error detect functions available (parity errors, framing errors, and overrun errors)

[I²C]

Standard-mode (Max.100 kbps) / Fast-mode (Max 400 kbps) supported

External Bus Interface

- Supports SRAM, NOR& NAND Flash device
- Up to 8 chip selects
- 8-/16-bit Data width
- Up to 25-bit Address bit
- Maximum area size: Up to 256 MB

DMA Controller (8 channels)

DMA Controller has an independent bus for CPU, so CPU and DMA Controller can process simultaneously.

- 8 independently configured and operated channels
- Transfer can be started by software or request from the built-in peripherals
- Transfer address area: 32 bit (4GB)
- Transfer mode: Block transfer/Burst transfer/Demand transfer
- Transfer data type: byte/half-word/word
- Transfer block count: 1 to 16
- Number of transfers: 1 to 65536

A/D Converter (Max. 16 channels)
[12-bit A/D Converter]

- Successive Approximation Register type
- Built-in 3unit
- Conversion time: 1.0 μs @ 5 V
- Priority conversion available (priority at 2 levels)
- Scanning conversion mode
- Built-in FIFO for conversion data storage (for SCAN conversion: 16 steps, for Priority conversion: 4steps)

Base Timer (Max. 8 channels)

Operation mode is selectable from the followings for each channel.

- 16-bit PWM timer
- 16-bit PPG timer
- 16-/32-bit reload timer
- 16-/32-bit PWC timer

Multi-function Timer (Max. 2 units)

The Multi-function timer is composed of the following blocks.

- 16-bit free-run timer × 3ch/unit
- Input capture × 4ch/unit
- Output compare × 6ch/unit
- A/D activation compare × 3ch/unit
- Waveform generator × 3ch/unit
- 16-bit PPG timer × 3ch/unit

The following function can be used to achieve the motor control.

- PWM signal output function
- DC chopper waveform output function
- Dead time function
- Input capture function
- A/D convertor activate function
- DTIF (Motor emergency stop) interrupt function

Quadrature Position/Revolution Counter (QPRC) (Max. 2 units)

The Quadrature Position/Revolution Counter (QPRC) is used to measure the position of the position encoder. Moreover, it is possible to use up/down counter.

- The detection edge of the three external event input pins AIN, BIN and ZIN is configurable.
- 16-bit position counter
- 16-bit revolution counter
- Two 16-bit compare registers

Dual Timer (Two 32/16-bit Down Counter)

The Dual Timer consists of two programmable 32/16-bit down counters.

Operation mode is selectable from the followings for each channel.

- Free-running
- Periodic (=Reload)
- One-shot

Watch Counter

The Watch counter is used for wake up from sleep mode.
 Interval timer: up to 64 s (Max.) @ Sub Clock: 32.768 kHz

Watch dog Timer (2 channels)

A watchdog timer can generate interrupts or a reset when a time-out value is reached.

This series consists of two different watchdogs, a "Hardware" watchdog and a "Software" watchdog.

"Hardware" watchdog timer is clocked by the built-in low-speed CR oscillator. Therefore, "Hardware" watchdog is active in any low-power consumption modes except STOP mode.

External Interrupt Controller Unit

- Up to 16 external vectors
- Include one non-maskable interrupt(NMI)

General Purpose I/O Port

This series can use its pins as general-purpose I/O ports when they are not used for external bus or peripherals. Moreover, the port relocate function is built in. It can set which I/O port the peripheral function can be allocated.

- Capable of pull-up control per pin
- Capable of reading pin level directly
- Built-in the port relocate function
- Up to 100 high-speed general-purpose I/O Ports @ 120pin Package

CRC (Cyclic Redundancy Check) Accelerator

The CRC accelerator helps a verify data transmission or storage integrity.

CCITT CRC16 and IEEE-802.3 CRC32 are supported.

- CCITT CRC16 Generator Polynomial: 0x1021
- IEEE-802.3 CRC32 Generator Polynomial: 0x04C11DB7

Clock and Reset

[Clocks]

Five clock sources (2 ext. osc, 2 CR osc, and Main PLL) that are dynamically selectable.

- Main Clock : 4 MHz to 48 MHz
- Sub Clock : 32.768 kHz
- Built-in high-speed CR Clock : 4 MHz
- Built-in low-speed CR Clock : 100 kHz
- Main PLL Clock

[Resets]

- Reset requests from INITX pins
- Power-on reset
- Software reset
- Watchdog timers reset
- Low-voltage detector reset
- Clock supervisor reset

Clock Super Visor (CSV)

Clocks generated by CR oscillators are used to supervise abnormality of the external clocks.

- External OSC clock failure (clock stop) is detected, reset is asserted.
- External OSC frequency anomaly is detected, interrupt or reset is asserted.

Low Voltage Detector (LVD)

This series include 2-stage monitoring of voltage on the VCC. When the voltage falls below the voltage has been set, Low Voltage Detector generates an interrupt or reset.

- LVD1: error reporting via interrupt
- LVD2: auto-reset operation

Low-Power Consumption Mode

Three low-power consumption modes supported.

- SLEEP
- TIMER
- STOP

Debug

- Serial Wire JTAG Debug Port (SWJ-DP)
- Embedded Trace Macrocells (ETM) provide comprehensive debug and trace facilities.

Power Supply

Two Power Supplies

- VCC = 2.7 V to 5.5 V: Correspond to the wide range voltage.
- USBVCC = 3.0 V to 3.6 V: for USB I/O voltage, when USB is used.
 = 2.7 V to 5.5 V: when GPIO is used.^[1]

Contents

| | |
|---|-----------|
| 1. Product Lineup | 6 |
| 2. Packages | 7 |
| 3. Pin Assignment | 8 |
| 4. List of Pin Functions | 11 |
| 5. I/O Circuit Type | 38 |
| 6. Handling Precautions | 42 |
| 6.1 Precautions for Product Design | 42 |
| 6.2 Precautions for Package Mounting..... | 43 |
| 6.3 Precautions for Use Environment..... | 44 |
| 7. Handling Devices | 45 |
| 8. Block Diagram | 47 |
| 9. Memory Size | 48 |
| 10. Memory Map | 48 |
| 11. Pin Status in Each CPU State | 51 |
| 12. Electrical Characteristics | 55 |
| 12.1 Absolute Maximum Ratings..... | 55 |
| 12.2 Recommended Operating Conditions | 57 |
| 12.3 DC Characteristics | 58 |
| 12.3.1 Current Rating..... | 58 |
| 12.3.2 Pin Characteristics | 60 |
| 12.4 AC Characteristics..... | 61 |
| 12.4.1 Main Clock Input Characteristics..... | 61 |
| 12.4.2 Sub Clock Input Characteristics | 62 |
| 12.4.3 Built-in CR Oscillation Characteristics..... | 63 |
| 12.4.4 Operating Conditions of Main and USB PLL (In the case of using main clock for input of PLL)..... | 64 |
| 12.4.5 Operating Conditions of Main PLL (In the case of using built-in high speed CR)..... | 64 |
| 12.4.6 Reset Input Characteristics | 66 |
| 12.4.7 Power-on Reset Timing..... | 66 |
| 12.4.8 External Bus Timing..... | 67 |
| 12.4.9 Base Timer Input Timing | 71 |
| 12.4.10 CSIO/UART Timing | 72 |
| 12.4.11 External Input Timing..... | 80 |
| 12.4.12 Quadrature Position/Revolution Counter timing..... | 81 |
| 12.4.13 I ² C Timing..... | 83 |
| 12.4.14 ETM Timing | 84 |
| 12.4.15 JTAG Timing..... | 85 |
| 12.5 12-bit A/D Converter | 86 |
| 12.6 USB Characteristics | 89 |
| 12.7 Low-Voltage Detection Characteristics..... | 93 |
| 12.7.1 Low-Voltage Detection Reset..... | 93 |
| 12.7.2 Interrupt of Low-Voltage Detection..... | 93 |
| 12.8 Flash Memory Write/Erase Characteristics | 94 |
| 12.8.1 Write / Erase time..... | 94 |
| 12.8.2 Erase/write cycles and data hold time..... | 94 |
| 12.9 Return Time from Low-Power Consumption Mode..... | 95 |
| 12.9.1 Return Factor: Interrupt..... | 95 |
| 12.9.2 Return Factor: Reset..... | 97 |

| | |
|---|------------|
| 13. Example of Characteristic | 99 |
| 14. Ordering Information | 101 |
| 15. Package Dimensions | 102 |
| 16. Errata..... | 105 |
| 16.1 Part Numbers Affected | 105 |
| 16.2 Qualification Status | 105 |
| 16.3 Errata Summary | 105 |
| 16.4 Errata Detail | 105 |
| 16.4.1 Timer and stop mode issue | 105 |
| 16.4.2 USB HOST issue | 106 |
| 16.4.3 Gap Between Watch Counter Value and Real Time at Return in Timer Mode..... | 106 |
| 17. Major Changes | 108 |
| Document History..... | 110 |
| Sales, Solutions, and Legal Information..... | 112 |

1. Product Lineup

Memory Size

| Product device | CY9BF304NB/RB | CY9BF305NB/RB | CY9BF306NB/RB |
|----------------------|---------------|---------------|---------------|
| On-chip Flash memory | 256 KB | 384 KB | 512 KB |
| On-chip SRAM | 32 KB | 48 KB | 64 KB |

Function

| Product device | CY9BF304NB CY9BF305NB CY9BF306NB | CY9BF304RB CY9BF305RB CY9BF306RB |
|--|--|---|
| Pin count | 100 | 120 |
| CPU | Cortex-M3 | |
| Freq. | 80 MHz | |
| Power supply voltage range | 2.7 V to 5.5 V | |
| USB2.0 (Device/Host) | 1 ch | |
| DMAC | 8 ch | |
| External Bus Interface | Addr: 25-bit (Max.) Data: 8-/16-bit CS: 5 (Max.) Support: SRAM, NOR Flash | Addr: 25-bit (Max.) Data: 8-/16-bit CS: 8 (Max.) Support: SRAM, NOR & NAND Flash |
| Multi-function Serial Interface (UART/CSIO/LIN/I ² C) | 8 ch (Max.) | |
| Base Timer (PWC/ Reload timer/PWM/PPG) | 8 ch (Max.) | |
| MF-Timer | A/D activation compare | 3 ch. |
| | Input capture | 4 ch. |
| | Free-run timer | 3 ch. |
| | Output compare | 6 ch. |
| | Waveform generator | 3 ch. |
| | PPG | 3 ch. |
| | 2 units (Max.) | |
| QPRC | 2 ch (Max.) | |
| Dual Timer | 1 unit | |
| Watch Counter | 1 unit | |
| CRC Accelerator | Yes | |
| Watchdog timer | 1ch(SW) + 1ch(HW) | |
| External Interrupts | 16 pins (Max.) + NMI × 1 | |
| I/O ports | 80 pins (Max.) | 100 pins (Max.) |
| 12 bit A/D converter | 16 ch (3 units) | |
| CSV (Clock Super Visor) | Yes | |
| LVD (Low Voltage Detector) | 2 ch | |
| Built-in CR | High-speed | 4 MHz |
| | Low-speed | 100 kHz |
| Debug Function | SWJ-DP/ETM | |

Note:

- All signals of the peripheral function in each product cannot be allocated by limiting the pins of package. It is necessary to use the port relocate function of the General I/O port according to your function use. See "12. Electrical Characteristics 12.4. AC Characteristics 12.4.3. Built-in CR Oscillation Characteristics" for accuracy of built-in CR.

2. Packages

| Package | Product name | CY9BF304NB CY9BF305NB CY9BF306NB | CY9BF304RB CY9BF305RB CY9BF306RB |
|-----------------------------|--------------|--|--|
| LQFP: LQI100 (0.5 mm pitch) | | ○ | - |
| LQFP: LQM120 (0.5 mm pitch) | | - | ○ |
| FBGA: LBC112 (0.8 mm pitch) | | ○ | - |

○: Supported

Note:

- Refer to "15. Package Dimensions" for detailed information on each package.

3. Pin Assignment

LQ100

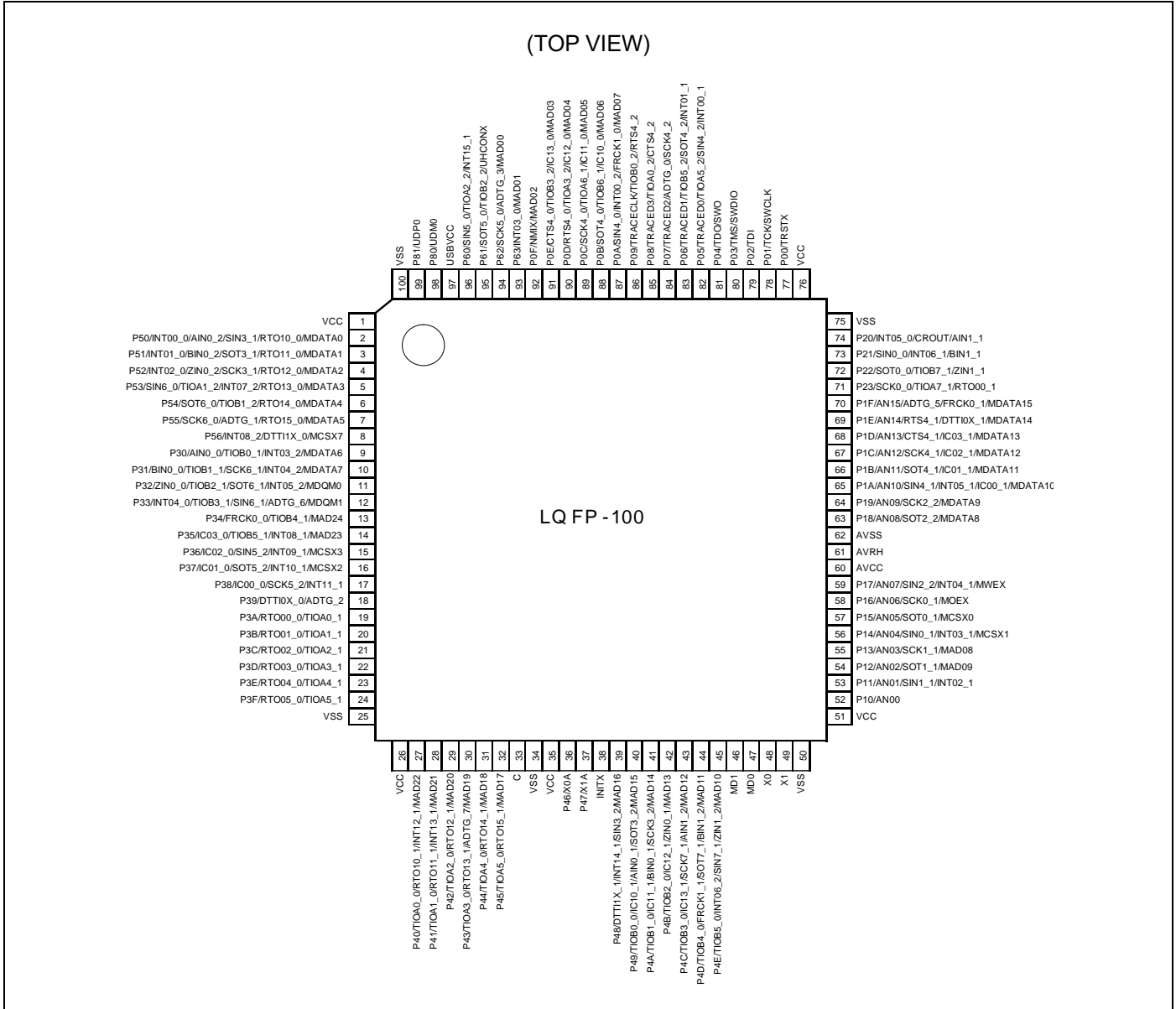

Note:

- The number after the underscore ("_") in pin names such as XXX_1 and XXX_2 indicates the relocated port number. For these pins, there are multiple pins that provide the same function for the same channel. Use the extended port function register (EPFR) to select the pin.

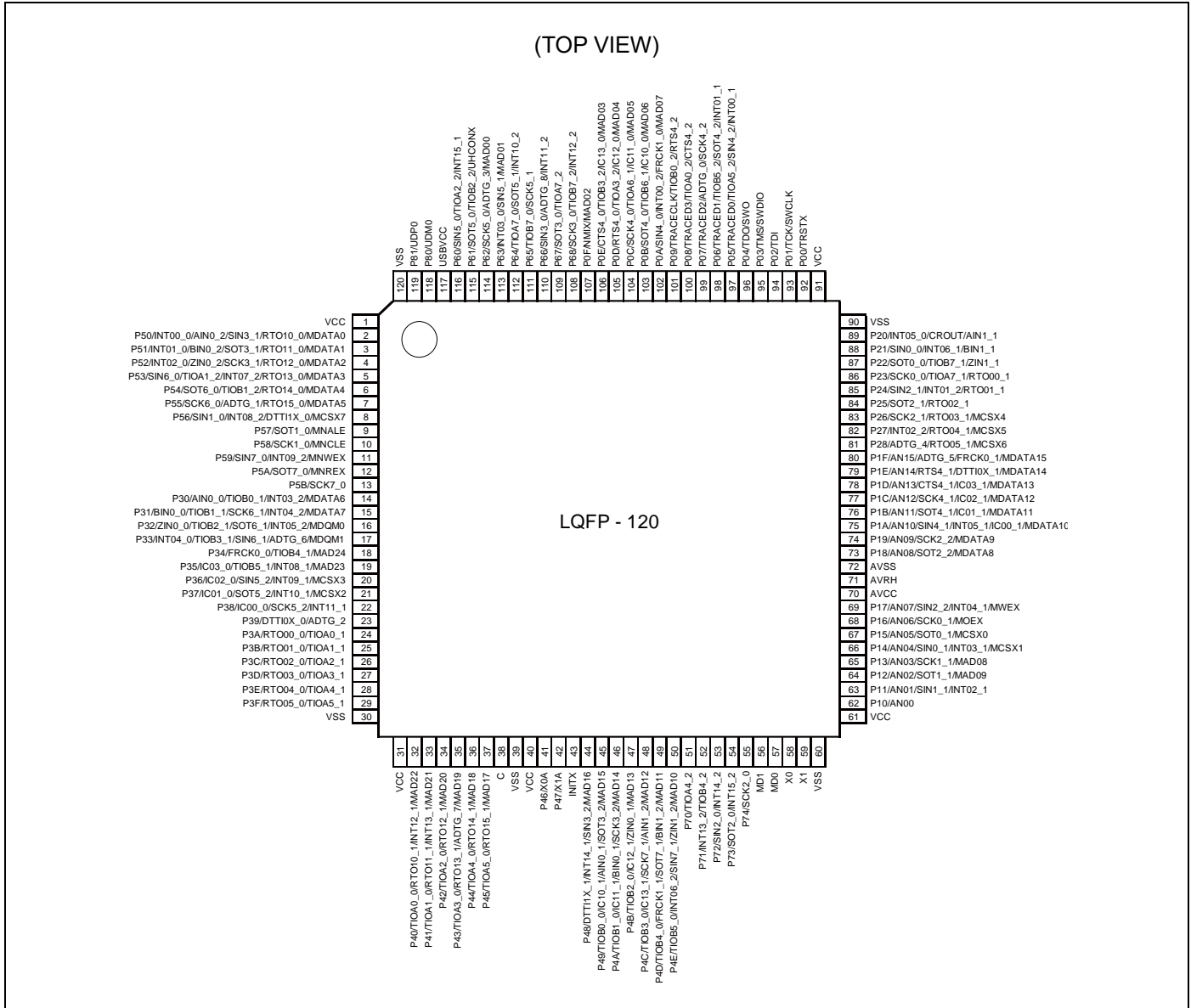
LQM120

Note:

- The number after the underscore ("_") in pin names such as XXX_1 and XXX_2 indicates the relocated port number. For these pins, there are multiple pins that provide the same function for the same channel. Use the extended port function register (EPFR) to select the pin.

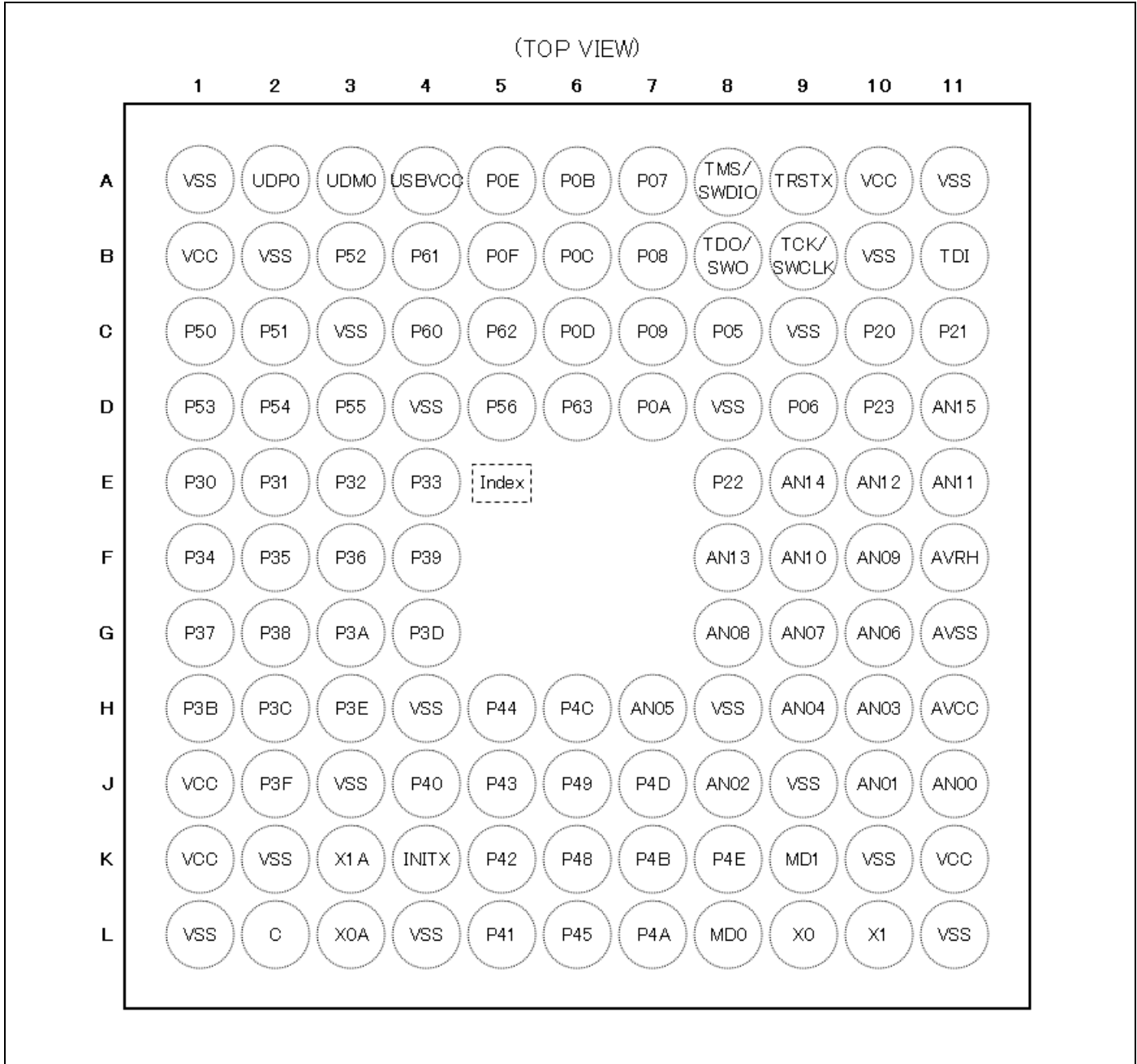
LBC112



Note:

- The number after the underscore ("_") in pin names such as XXX_1 and XXX_2 indicates the relocated port number. For these pins, there are multiple pins that provide the same function for the same channel. Use the extended port function register (EPFR) to select the pin.

4. List of Pin Functions

List of pin numbers

The number after the underscore ("_") in pin names such as XXX_1 and XXX_2 indicates the relocated port number. For these pins, there are multiple pins that provide the same function for the same channel. Use the extended port function register (EPFR) to select the pin.

| Pin no. | | | Pin name | I/O circuit type | Pin state type |
|----------|---------|----------|----------------------|------------------|----------------|
| LQFP-100 | BGA-112 | LQFP-120 | | | |
| 1 | B1 | 1 | VCC | - | |
| 2 | C1 | 2 | P50 | E | H |
| | | | INT00_0 | | |
| | | | AIN0_2 | | |
| | | | SIN3_1 | | |
| | | | RTO10_0 (PPG10_0) | | |
| | | | MDATA0 | | |
| 3 | C2 | 3 | P51 | E | H |
| | | | INT01_0 | | |
| | | | BIN0_2 | | |
| | | | SOT3_1 (SDA3_1) | | |
| | | | RTO11_0 (PPG10_0) | | |
| | | | MDATA1 | | |
| 4 | B3 | 4 | P52 | E | H |
| | | | INT02_0 | | |
| | | | ZIN0_2 | | |
| | | | SCK3_1 (SCL3_1) | | |
| | | | RTO12_0 (PPG12_0) | | |
| | | | MDATA2 | | |
| 5 | D1 | 5 | P53 | E | H |
| | | | SIN6_0 | | |
| | | | TIOA1_2 | | |
| | | | INT07_2 | | |
| | | | RTO13_0 (PPG12_0) | | |
| | | | MDATA3 | | |
| 6 | D2 | 6 | P54 | E | I |
| | | | SOT6_0 (SDA6_0) | | |
| | | | TI0B1_2 | | |
| | | | RTO14_0 (PPG14_0) | | |
| | | | MDATA4 | | |

| Pin no. | | | Pin name | I/O circuit type | Pin state type |
|----------|---------|----------|-------------------------|------------------|----------------|
| LQFP-100 | BGA-112 | LQFP-120 | | | |
| 7 | D3 | 7 | P55 | E | I |
| | | | SCK6_0 (SCL6_0) | | |
| | | | ADTG_1 | | |
| | | | RTO15_0 (PPG14_0) | | |
| | | | MDATA5 | | |
| 8 | D5 | 8 | P56 | E | H |
| | | | SIN1_0 (120pin only) | | |
| | | | INT08_2 | | |
| | | | DTT11X_0 | | |
| - | - | 9 | P57 | E | I |
| | | | SOT1_0 (SDA1_0) | | |
| | | | MNALE | | |
| - | - | 10 | P58 | E | I |
| | | | SCK1_0 (SCL1_0) | | |
| | | | MNCLE | | |
| - | - | 11 | P59 | E | H |
| | | | SIN7_0 | | |
| | | | INT09_2 | | |
| - | - | 12 | P5A | E | I |
| | | | SOT7_0 (SDA7_0) | | |
| | | | MNREX | | |
| - | - | 13 | P5B | E | I |
| | | | SCK7_0 (SCL7_0) | | |
| 9 | E1 | 14 | P30 | E | H |
| | | | AIN0_0 | | |
| | | | TIOB0_1 | | |
| | | | INT03_2 | | |
| | | | MDATA6 | | |

| Pin no. | | | Pin name | I/O circuit type | Pin state type |
|----------|---------|----------|--------------------|------------------|----------------|
| LQFP-100 | BGA-112 | LQFP-120 | | | |
| 10 | E2 | 15 | P31 | E | H |
| | | | BIN0_0 | | |
| | | | TIOB1_1 | | |
| | | | SCK6_1 (SCL6_1) | | |
| | | | INT04_2 | | |
| | | | MDATA7 | | |
| 11 | E3 | 16 | P32 | E | H |
| | | | ZIN0_0 | | |
| | | | TIOB2_1 | | |
| | | | SOT6_1 (SDA6_1) | | |
| | | | INT05_2 | | |
| | | | MDQM0 | | |
| 12 | E4 | 17 | P33 | E | H |
| | | | INT04_0 | | |
| | | | TIOB3_1 | | |
| | | | SIN6_1 | | |
| | | | ADTG_6 | | |
| | | | MDQM1 | | |
| 13 | F1 | 18 | P34 | E | I |
| | | | FRCK0_0 | | |
| | | | TIOB4_1 | | |
| | | | MAD24 | | |
| 14 | F2 | 19 | P35 | E | H |
| | | | IC03_0 | | |
| | | | TIOB5_1 | | |
| | | | INT08_1 | | |
| | | | MAD23 | | |
| 15 | F3 | 20 | P36 | E | H |
| | | | IC02_0 | | |
| | | | SIN5_2 | | |
| | | | INT09_1 | | |
| | | | MCSX3 | | |
| 16 | G1 | 21 | P37 | E | H |
| | | | IC01_0 | | |
| | | | SOT5_2 (SDA5_2) | | |
| | | | INT10_1 | | |
| | | | MCSX2 | | |
| 17 | G2 | 22 | P38 | E | H |
| | | | IC00_0 | | |
| | | | SCK5_2 (SCL5_2) | | |
| | | | INT11_1 | | |

| Pin no. | | | Pin name | I/O circuit type | Pin state type |
|----------|---------|----------|----------------------|------------------|----------------|
| LQFP-100 | BGA-112 | LQFP-120 | | | |
| 18 | F4 | 23 | P39 | E | I |
| | | | DTTI0X_0 | | |
| | | | ADTG_2 | | |
| 19 | G3 | 24 | P3A | G | I |
| | | | RTO00_0 (PPG00_0) | | |
| | | | TIOA0_1 | | |
| - | B2 | - | VSS | - | |
| 20 | H1 | 25 | P3B | G | I |
| | | | RTO01_0 (PPG00_0) | | |
| | | | TIOA1_1 | | |
| 21 | H2 | 26 | P3C | G | I |
| | | | RTO02_0 (PPG02_0) | | |
| | | | TIOA2_1 | | |
| 22 | G4 | 27 | P3D | G | I |
| | | | RTO03_0 (PPG02_0) | | |
| | | | TIOA3_1 | | |
| 23 | H3 | 28 | P3E | G | I |
| | | | RTO04_0 (PPG04_0) | | |
| | | | TIOA4_1 | | |
| 24 | J2 | 29 | P3F | G | I |
| | | | RTO05_0 (PPG04_0) | | |
| | | | TIOA5_1 | | |
| 25 | L1 | 30 | VSS | - | |
| 26 | J1 | 31 | VCC | - | |
| 27 | J4 | 32 | P40 | G | H |
| | | | TIOA0_0 | | |
| | | | RTO10_1 (PPG10_1) | | |
| | | | INT12_1 | | |
| | | | MAD22 | | |
| 28 | L5 | 33 | P41 | G | H |
| | | | TIOA1_0 | | |
| | | | RTO11_1 (PPG10_1) | | |
| | | | INT13_1 | | |
| | | | MAD21 | | |

| Pin no. | | | Pin name | I/O circuit type | Pin state type |
|----------|---------|----------|----------------------|------------------|----------------|
| LQFP-100 | BGA-112 | LQFP-120 | | | |
| 29 | K5 | 34 | P42 | G | I |
| | | | TIOA2_0 | | |
| | | | RTO12_1 (PPG12_1) | | |
| | | | MAD20 | | |
| 30 | J5 | 35 | P43 | G | I |
| | | | TIOA3_0 | | |
| | | | RTO13_1 (PPG12_1) | | |
| | | | ADTG_7 | | |
| | | | MAD19 | | |
| - | K2 | - | VSS | - | |
| - | J3 | - | VSS | - | |
| - | H4 | - | VSS | - | |
| 31 | H5 | 36 | P44 | G | I |
| | | | TIOA4_0 | | |
| | | | RTO14_1 (PPG14_1) | | |
| | | | MAD18 | | |
| 32 | L6 | 37 | P45 | G | I |
| | | | TIOA5_0 | | |
| | | | RTO15_1 (PPG14_1) | | |
| | | | MAD17 | | |
| 33 | L2 | 38 | C | - | |
| 34 | L4 | 39 | VSS | - | |
| 35 | K1 | 40 | VCC | - | |
| 36 | L3 | 41 | P46 | D | M |
| | | | X0A | | |
| 37 | K3 | 42 | P47 | D | N |
| | | | X1A | | |
| 38 | K4 | 43 | INITX | B | C |
| 39 | K6 | 44 | P48 | E | H |
| | | | DTTI1X_1 | | |
| | | | INT14_1 | | |
| | | | SIN3_2 | | |
| | | | MAD16 | | |
| 40 | J6 | 45 | P49 | E | I |
| | | | TIOB0_0 | | |
| | | | IC10_1 | | |
| | | | AIN0_1 | | |
| | | | SOT3_2 (SDA3_2) | | |
| | | | MAD15 | | |

| Pin no. | | | Pin name | I/O circuit type | Pin state type |
|----------|---------|----------|--------------------|------------------|----------------|
| LQFP-100 | BGA-112 | LQFP-120 | | | |
| 41 | L7 | 46 | P4A | E | I |
| | | | TIOB1_0 | | |
| | | | IC11_1 | | |
| | | | BIN0_1 | | |
| | | | SCK3_2 (SCL3_2) | | |
| | | | MAD14 | | |
| 42 | K7 | 47 | P4B | E | I |
| | | | TIOB2_0 | | |
| | | | IC12_1 | | |
| | | | ZIN0_1 | | |
| | | | MAD13 | | |
| 43 | H6 | 48 | P4C | E | I |
| | | | TIOB3_0 | | |
| | | | IC13_1 | | |
| | | | SCK7_1 (SCL7_1) | | |
| | | | AIN1_2 | | |
| | | | MAD12 | | |
| 44 | J7 | 49 | P4D | E | I |
| | | | TIOB4_0 | | |
| | | | FRCK1_1 | | |
| | | | SOT7_1 (SDA7_1) | | |
| | | | BIN1_2 | | |
| | | | MAD11 | | |
| 45 | K8 | 50 | P4E | E | H |
| | | | TIOB5_0 | | |
| | | | INT06_2 | | |
| | | | SIN7_1 | | |
| | | | ZIN1_2 | | |
| | | | MAD10 | | |
| - | - | 51 | P70 | E | I |
| | | | TIOA4_2 | | |
| - | - | 52 | P71 | E | H |
| | | | INT13_2 | | |
| | | | TIOB4_2 | | |
| - | - | 53 | P72 | E | H |
| | | | SIN2_0 | | |
| | | | INT14_2 | | |

| Pin no. | | | Pin name | I/O circuit type | Pin state type |
|----------|---------|----------|--|------------------|----------------|
| LQFP-100 | BGA-112 | LQFP-120 | | | |
| - | - | 54 | P73 SOT2_0 (SDA2_0) INT15_2 | E | H |
| - | - | 55 | P74 SCK2_0 (SCL2_0) | E | I |
| 46 | K9 | 56 | MD1 | C | D |
| 47 | L8 | 57 | MD0 | C | D |
| 48 | L9 | 58 | X0 | A | A |
| 49 | L10 | 59 | X1 | A | B |
| 50 | L11 | 60 | VSS | - | |
| 51 | K11 | 61 | VCC | - | |
| 52 | J11 | 62 | P10 AN00 | F | K |
| 53 | J10 | 63 | P11 AN01 SIN1_1 INT02_1 | F | L |
| - | K10 | - | VSS | - | |
| - | J9 | - | VSS | - | |
| 54 | J8 | 64 | P12 AN02 SOT1_1 (SDA1_1) MAD09 | F | K |
| 55 | H10 | 65 | P13 AN03 SCK1_1 (SCL1_1) MAD08 | F | K |
| 56 | H9 | 66 | P14 AN04 SIN0_1 INT03_1 MCSX1 | F | L |
| 57 | H7 | 67 | P15 AN05 SOT0_1 (SDA0_1) MCSX0 | F | K |

| Pin no. | | | Pin name | I/O circuit type | Pin state type |
|----------|---------|----------|--------------------|------------------|----------------|
| LQFP-100 | BGA-112 | LQFP-120 | | | |
| 58 | G10 | 68 | P16 | F | K |
| | | | AN06 | | |
| | | | SCK0_1 (SCL0_1) | | |
| | | | MOEX | | |
| 59 | G9 | 69 | P17 | F | L |
| | | | AN07 | | |
| | | | SIN2_2 | | |
| | | | INT04_1 | | |
| 60 | H11 | 70 | AVCC | - | |
| 61 | F11 | 71 | AVRH | - | |
| 62 | G11 | 72 | AVSS | - | |
| 63 | G8 | 73 | P18 | F | K |
| | | | AN08 | | |
| | | | SOT2_2 (SDA2_2) | | |
| | | | MDATA8 | | |
| 64 | F10 | 74 | P19 | F | K |
| | | | AN09 | | |
| | | | SCK2_2 (SCL2_2) | | |
| | | | MDATA9 | | |
| 65 | F9 | 75 | P1A | F | L |
| | | | AN10 | | |
| | | | SIN4_1 | | |
| | | | INT05_1 | | |
| | | | IC00_1 | | |
| | | | MDATA10 | | |
| - | H8 | - | VSS | - | |
| 66 | E11 | 76 | P1B | F | K |
| | | | AN11 | | |
| | | | SOT4_1 (SDA4_1) | | |
| | | | IC01_1 | | |
| | | | MDATA11 | | |
| 67 | E10 | 77 | P1C | F | K |
| | | | AN12 | | |
| | | | SCK4_1 (SCL4_1) | | |
| | | | IC02_1 | | |
| | | | MDATA12 | | |

| Pin no. | | | Pin name | I/O circuit type | Pin state type |
|----------|---------|----------|----------------------|------------------|----------------|
| LQFP-100 | BGA-112 | LQFP-120 | | | |
| 68 | F8 | 78 | P1D | F | K |
| | | | AN13 | | |
| | | | CTS4_1 | | |
| | | | IC03_1 | | |
| | | | MDATA13 | | |
| 69 | E9 | 79 | P1E | F | K |
| | | | AN14 | | |
| | | | RTS4_1 | | |
| | | | DTTI0X_1 | | |
| | | | MDATA14 | | |
| 70 | D11 | 80 | P1F | F | K |
| | | | AN15 | | |
| | | | ADTG_5 | | |
| | | | FRCK0_1 | | |
| | | | MDATA15 | | |
| - | - | 81 | P28 | E | I |
| | | | ADTG_4 | | |
| | | | RTO05_1 (PPG04_1) | | |
| | | | MCSX6 | | |
| - | - | 82 | P27 | E | H |
| | | | INT02_2 | | |
| | | | RTO04_1 (PPG04_1) | | |
| | | | MCSX5 | | |
| - | - | 83 | P26 | E | I |
| | | | SCK2_1 (SCL2_1) | | |
| | | | RTO03_1 (PPG02_1) | | |
| | | | MCSX4 | | |
| - | - | 84 | P25 | E | I |
| | | | SOT2_1 (SDA2_1) | | |
| | | | RTO02_1 (PPG02_1) | | |
| - | B10 | - | VSS | - | - |
| - | C9 | - | VSS | - | - |
| - | - | 85 | P24 | E | H |
| | | | SIN2_1 | | |
| | | | INT01_2 | | |
| | | | RTO01_1 (PPG00_1) | | |

| Pin no. | | | Pin name | I/O circuit type | Pin state type |
|----------|---------|----------|----------------------|------------------|----------------|
| LQFP-100 | BGA-112 | LQFP-120 | | | |
| 71 | D10 | 86 | P23 | E | I |
| | | | SCK0_0 (SCL0_0) | | |
| | | | TIOA7_1 | | |
| | | | RTO00_1 (PPG00_1) | | |
| 72 | E8 | 87 | P22 | E | I |
| | | | SOT0_0 (SDA0_0) | | |
| | | | TIOB7_1 | | |
| | | | ZIN1_1 | | |
| 73 | C11 | 88 | P21 | E | H |
| | | | SIN0_0 | | |
| | | | INT06_1 | | |
| | | | BIN1_1 | | |
| 74 | C10 | 89 | P20 | E | H |
| | | | INT05_0 | | |
| | | | CROUT | | |
| | | | AIN1_1 | | |
| 75 | A11 | 90 | VSS | - | |
| 76 | A10 | 91 | VCC | - | |
| 77 | A9 | 92 | P00 | E | E |
| | | | TRSTX | | |
| 78 | B9 | 93 | P01 | E | E |
| | | | TCK | | |
| | | | SWCLK | | |
| 79 | B11 | 94 | P02 | E | E |
| | | | TDI | | |
| 80 | A8 | 95 | P03 | E | E |
| | | | TMS | | |
| | | | SWDIO | | |
| 81 | B8 | 96 | P04 | E | E |
| | | | TDO | | |
| | | | SWO | | |
| 82 | C8 | 97 | P05 | E | F |
| | | | TRACED0 | | |
| | | | TIOA5_2 | | |
| | | | SIN4_2 | | |
| | | | INT00_1 | | |
| - | D8 | - | VSS | - | |

| Pin no. | | | Pin name | I/O circuit type | Pin state type |
|----------|---------|----------|--------------------|------------------|----------------|
| LQFP-100 | BGA-112 | LQFP-120 | | | |
| 83 | D9 | 98 | P06 | E | F |
| | | | TRACED1 | | |
| | | | TIOB5_2 | | |
| | | | SOT4_2 (SDA4_2) | | |
| | | | INT01_1 | | |
| 84 | A7 | 99 | P07 | E | G |
| | | | TRACED2 | | |
| | | | ADTG_0 | | |
| | | | SCK4_2 (SCL4_2) | | |
| 85 | B7 | 100 | P08 | E | G |
| | | | TRACED3 | | |
| | | | TIOA0_2 | | |
| | | | CTS4_2 | | |
| 86 | C7 | 101 | P09 | E | G |
| | | | TRACECLK | | |
| | | | TIOB0_2 | | |
| | | | RTS4_2 | | |
| 87 | D7 | 102 | P0A | E | H |
| | | | SIN4_0 | | |
| | | | INT00_2 | | |
| | | | FRCK1_0 | | |
| | | | MAD07 | | |
| 88 | A6 | 103 | P0B | E | I |
| | | | SOT4_0 (SDA4_0) | | |
| | | | TIOB6_1 | | |
| | | | IC10_0 | | |
| | | | MAD06 | | |
| 89 | B6 | 104 | P0C | E | I |
| | | | SCK4_0 (SCL4_0) | | |
| | | | TIOA6_1 | | |
| | | | IC11_0 | | |
| | | | MAD05 | | |
| 90 | C6 | 105 | P0D | E | I |
| | | | RTS4_0 | | |
| | | | TIOA3_2 | | |
| | | | IC12_0 | | |
| | | | MAD04 | | |

| Pin no. | | | Pin name | I/O circuit type | Pin state typet |
|----------|---------|----------|--------------------|------------------|-----------------|
| LQFP-100 | BGA-112 | LQFP-120 | | | |
| 91 | A5 | 106 | P0E | E | I |
| | | | CTS4_0 | | |
| | | | TIOB3_2 | | |
| | | | IC13_0 | | |
| | | | MAD03 | | |
| - | D4 | - | VSS | - | |
| - | C3 | - | VSS | - | |
| 92 | B5 | 107 | P0F | E | J |
| | | | NMIX | | |
| | | | MAD02 | | |
| - | - | 108 | P68 | E | H |
| | | | SCK3_0 (SCL3_0) | | |
| | | | TIOB7_2 | | |
| | | | INT12_2 | | |
| - | - | 109 | P67 | E | I |
| | | | SOT3_0 (SDA3_0) | | |
| | | | TIOA7_2 | | |
| - | - | 110 | P66 | E | H |
| | | | SIN3_0 | | |
| | | | ADTG_8 | | |
| | | | INT11_2 | | |
| - | - | 111 | P65 | E | I |
| | | | TIOB7_0 | | |
| | | | SCK5_1 (SCL5_1) | | |
| - | - | 112 | P64 | E | H |
| | | | TIOA7_0 | | |
| | | | SOT5_1 (SDA5_1) | | |
| | | | INT10_2 | | |
| 93 | D6 | 113 | P63 | E | H |
| | | | INT03_0 | | |
| | | | MAD01 | | |
| - | - | - | SIN5_1 | | |
| 94 | C5 | 114 | P62 | E | I |
| | | | SCK5_0 (SCL5_0) | | |
| | | | ADTG_3 | | |
| | | | MAD00 | | |
| 95 | B4 | 115 | P61 | E | I |
| | | | SOT5_0 (SDA5_0) | | |
| | | | TIOB2_2 | | |
| | | | UHCONX | | |

| Pin no. | | | Pin name | I/O circuit type | Pin state type |
|----------|---------|----------|----------|------------------|----------------|
| LQFP-100 | BGA-112 | LQFP-120 | | | |
| 96 | C4 | 116 | P60 | E | H |
| | | | SIN5_0 | | |
| | | | TIOA2_2 | | |
| | | | INT15_1 | | |
| 97 | A4 | 117 | USBVCC | - | |
| 98 | A3 | 118 | P80 | H | O |
| | | | UDM0 | | |
| 99 | A2 | 119 | P81 | H | O |
| | | | UDP0 | | |
| 100 | A1 | 120 | VSS | - | |

List of pin functions

The number after the underscore ("_") in pin names such as XXX_1 and XXX_2 indicates the relocated port number. For these pins, there are multiple pins that provide the same function for the same channel. Use the extended port function register (EPFR) to select the pin.

| Module | Pin name | Function | Pin No. | | |
|--------------|----------|--|----------|---------|----------|
| | | | LQFP-100 | BGA-112 | LQFP-120 |
| ADC | ADTG_0 | A/D converter external trigger input pin. | 84 | A7 | 99 |
| | ADTG_1 | | 7 | D3 | 7 |
| | ADTG_2 | | 18 | F4 | 23 |
| | ADTG_3 | | 94 | C5 | 114 |
| | ADTG_4 | | - | - | 81 |
| | ADTG_5 | | 70 | D11 | 80 |
| | ADTG_6 | | 12 | E4 | 17 |
| | ADTG_7 | | 30 | J5 | 35 |
| | ADTG_8 | | - | - | 110 |
| | AN00 | A/D converter analog input pin. ANxx describes ADC ch.xx. | 52 | J11 | 62 |
| | AN01 | | 53 | J10 | 63 |
| | AN02 | | 54 | J8 | 64 |
| | AN03 | | 55 | H10 | 65 |
| | AN04 | | 56 | H9 | 66 |
| | AN05 | | 57 | H7 | 67 |
| | AN06 | | 58 | G10 | 68 |
| | AN07 | | 59 | G9 | 69 |
| | AN08 | | 63 | G8 | 73 |
| | AN09 | | 64 | F10 | 74 |
| | AN10 | | 65 | F9 | 75 |
| | AN11 | | 66 | E11 | 76 |
| | AN12 | | 67 | E10 | 77 |
| | AN13 | | 68 | F8 | 78 |
| | AN14 | | 69 | E9 | 79 |
| AN15 | 70 | D11 | 80 | | |
| Base Timer 0 | TIOA0_0 | Base timer ch.0 TIOA pin. | 27 | J4 | 32 |
| | TIOA0_1 | | 19 | G3 | 24 |
| | TIOA0_2 | | 85 | B7 | 100 |
| | TIOB0_0 | Base timer ch.0 TIOB pin. | 40 | J6 | 45 |
| | TIOB0_1 | | 9 | E1 | 14 |
| | TIOB0_2 | | 86 | C7 | 101 |
| Base Timer 1 | TIOA1_0 | Base timer ch.1 TIOA pin. | 28 | L5 | 33 |
| | TIOA1_1 | | 20 | H1 | 25 |
| | TIOA1_2 | | 5 | D1 | 5 |
| | TIOB1_0 | Base timer ch.1 TIOB pin. | 41 | L7 | 46 |
| | TIOB1_1 | | 10 | E2 | 15 |
| | TIOB1_2 | | 6 | D2 | 6 |
| Base Timer 2 | TIOA2_0 | Base timer ch.2 TIOA pin. | 29 | K5 | 34 |
| | TIOA2_1 | | 21 | H2 | 26 |
| | TIOA2_2 | | 96 | C4 | 116 |
| | TIOB2_0 | Base timer ch.2 TIOB pin. | 42 | K7 | 47 |
| | TIOB2_1 | | 11 | E3 | 16 |
| | TIOB2_2 | | 95 | B4 | 115 |

| Module | Pin name | Function | Pin No. | | |
|--------------|----------|--|------------------------|---------|----------|
| | | | LQFP-100 | BGA-112 | LQFP-120 |
| Base Timer 3 | TIOA3_0 | Base timer ch.3 TIOA pin. | 30 | J5 | 35 |
| | TIOA3_1 | | 22 | G4 | 27 |
| | TIOA3_2 | | 90 | C6 | 105 |
| | TIOB3_0 | Base timer ch.3 TIOB pin. | 43 | H6 | 48 |
| | TIOB3_1 | | 12 | E4 | 17 |
| | TIOB3_2 | | 91 | A5 | 106 |
| Base Timer 4 | TIOA4_0 | Base timer ch.4 TIOA pin. | 31 | H5 | 36 |
| | TIOA4_1 | | 23 | H3 | 28 |
| | TIOA4_2 | | - | - | 51 |
| | TIOB4_0 | Base timer ch.4 TIOB pin. | 44 | J7 | 49 |
| | TIOB4_1 | | 13 | F1 | 18 |
| | TIOB4_2 | | - | - | 52 |
| Base Timer 5 | TIOA5_0 | Base timer ch.5 TIOA pin. | 32 | L6 | 37 |
| | TIOA5_1 | | 24 | J2 | 29 |
| | TIOA5_2 | | 82 | C8 | 97 |
| | TIOB5_0 | Base timer ch.5 TIOB pin. | 45 | K8 | 50 |
| | TIOB5_1 | | 14 | F2 | 19 |
| | TIOB5_2 | | 83 | D9 | 98 |
| Base Timer 6 | TIOA6_1 | Base timer ch.6 TIOA pin. | 89 | B6 | 104 |
| | TIOB6_1 | Base timer ch.6 TIOB pin. | 88 | A6 | 103 |
| Base Timer 7 | TIOA7_0 | Base timer ch.7 TIOA pin. | - | - | 112 |
| | TIOA7_1 | | 71 | D10 | 86 |
| | TIOA7_2 | | - | - | 109 |
| | TIOB7_0 | Base timer ch.7 TIOB pin. | - | - | 111 |
| | TIOB7_1 | | 72 | E8 | 87 |
| | TIOB7_2 | | - | - | 108 |
| Debugger | SWCLK | Serial wire debug interface clock input. | 78 | B9 | 93 |
| | SWDIO | Serial wire debug interface data input / output. | 80 | A8 | 95 |
| | SWO | Serial wire viewer output. | 81 | B8 | 96 |
| | TCK | JTAG test clock input. | 78 | B9 | 93 |
| | TDI | JTAG test data input. | 79 | B11 | 94 |
| | TDO | JTAG debug data output. | 81 | B8 | 96 |
| | TMS | JTAG test mode state input/output. | 80 | A8 | 95 |
| | TRACECLK | Trace CLK output of ETM. | 86 | C7 | 101 |
| | TRACED0 | Trace data output of ETM. | 82 | C8 | 97 |
| | TRACED1 | | 83 | D9 | 98 |
| | TRACED2 | | 84 | A7 | 99 |
| | TRACED3 | | 85 | B7 | 100 |
| | TRSTX | | JTAG test reset Input. | 77 | A9 |

| Module | Pin name | Function | Pin No. | | |
|--------------|---|--|----------|---------|----------|
| | | | LQFP-100 | BGA-112 | LQFP-120 |
| External Bus | MAD00 | External bus interface address bus. | 94 | C5 | 114 |
| | MAD01 | | 93 | D6 | 113 |
| | MAD02 | | 92 | B5 | 107 |
| | MAD03 | | 91 | A5 | 106 |
| | MAD04 | | 90 | C6 | 105 |
| | MAD05 | | 89 | B6 | 104 |
| | MAD06 | | 88 | A6 | 103 |
| | MAD07 | | 87 | D7 | 102 |
| | MAD08 | | 55 | H10 | 65 |
| | MAD09 | | 54 | J8 | 64 |
| | MAD10 | | 45 | K8 | 50 |
| | MAD11 | | 44 | J7 | 49 |
| | MAD12 | | 43 | H6 | 48 |
| | MAD13 | | 42 | K7 | 47 |
| | MAD14 | | 41 | L7 | 46 |
| | MAD15 | | 40 | J6 | 45 |
| | MAD16 | | 39 | K6 | 44 |
| | MAD17 | | 32 | L6 | 37 |
| | MAD18 | | 31 | H5 | 36 |
| | MAD19 | | 30 | J5 | 35 |
| | MAD20 | | 29 | K5 | 34 |
| | MAD21 | | 28 | L5 | 33 |
| | MAD22 | | 27 | J4 | 32 |
| | MAD23 | | 14 | F2 | 19 |
| | MAD24 | 13 | F1 | 18 | |
| | MCSX0 | External bus interface chip select output pin. | 57 | H7 | 67 |
| | MCSX1 | | 56 | H9 | 66 |
| | MCSX2 | | 16 | G1 | 21 |
| | MCSX3 | | 15 | F3 | 20 |
| | MCSX4 | | - | - | 83 |
| | MCSX5 | | - | - | 82 |
| | MCSX6 | | - | - | 81 |
| | MCSX7 | 8 | D5 | 8 | |
| | MDATA0 | External bus interface data bus. | 2 | C1 | 2 |
| | MDATA1 | | 3 | C2 | 3 |
| | MDATA2 | | 4 | B3 | 4 |
| | MDATA3 | | 5 | D1 | 5 |
| | MDATA4 | | 6 | D2 | 6 |
| | MDATA5 | | 7 | D3 | 7 |
| | MDATA6 | | 9 | E1 | 14 |
| | MDATA7 | | 10 | E2 | 15 |
| | MDATA8 | | 63 | G8 | 73 |
| | MDATA9 | | 64 | F10 | 74 |
| | MDATA10 | | 65 | F9 | 75 |
| | MDATA11 | | 66 | E11 | 76 |
| | MDATA12 | | 67 | E10 | 77 |
| | MDATA13 | | 68 | F8 | 78 |
| MDATA14 | 69 | | E9 | 79 | |
| MDATA15 | 70 | D11 | 80 | | |
| MDQM0 | External bus interface byte mask signal output. | 11 | E3 | 16 | |
| MDQM1 | | 12 | E4 | 17 | |

| Module | Pin name | Function | Pin No. | | |
|--------------|----------|---|----------|---------|----------|
| | | | LQFP-100 | BGA-112 | LQFP-120 |
| External Bus | MNALE | External bus interface ALE signal to control NAND Flash output pin. | - | - | 9 |
| | MNCLE | External bus interface CLE signal to control NAND Flash output pin. | - | - | 10 |
| | MNREX | External bus interface read enable signal to control NAND Flash. | - | - | 12 |
| | MNWEX | External bus interface write enable signal to control NAND Flash. | - | - | 11 |
| | MOEX | External bus interface read enable signal for SRAM. | 58 | G10 | 68 |
| | MWEX | External bus interface write enable signal for SRAM. | 59 | G9 | 69 |

| Module | Pin name | Function | Pin No. | | |
|--------------------|--|--|----------|---------|----------|
| | | | LQFP-100 | BGA-112 | LQFP-120 |
| External Interrupt | INT00_0 | External interrupt request 00 input pin. | 2 | C1 | 2 |
| | INT00_1 | | 82 | C8 | 97 |
| | INT00_2 | | 87 | D7 | 102 |
| | INT01_0 | External interrupt request 01 input pin. | 3 | C2 | 3 |
| | INT01_1 | | 83 | D9 | 98 |
| | INT01_2 | | - | - | 85 |
| | INT02_0 | External interrupt request 02 input pin. | 4 | B3 | 4 |
| | INT02_1 | | 53 | J10 | 63 |
| | INT02_2 | | - | - | 82 |
| | INT03_0 | External interrupt request 03 input pin. | 93 | D6 | 113 |
| | INT03_1 | | 56 | H9 | 66 |
| | INT03_2 | | 9 | E1 | 14 |
| | INT04_0 | External interrupt request 04 input pin. | 12 | E4 | 17 |
| | INT04_1 | | 59 | G9 | 69 |
| | INT04_2 | | 10 | E2 | 15 |
| | INT05_0 | External interrupt request 05 input pin. | 74 | C10 | 89 |
| | INT05_1 | | 65 | F9 | 75 |
| | INT05_2 | | 11 | E3 | 16 |
| | INT06_1 | External interrupt request 06 input pin. | 73 | C11 | 88 |
| | INT06_2 | | 45 | K8 | 50 |
| | INT07_2 | External interrupt request 07 input pin. | 5 | D1 | 5 |
| | INT08_1 | External interrupt request 08 input pin. | 14 | F2 | 19 |
| | INT08_2 | | 8 | D5 | 8 |
| | INT09_1 | External interrupt request 09 input pin. | 15 | F3 | 20 |
| | INT09_2 | | - | - | 11 |
| | INT10_1 | External interrupt request 10 input pin. | 16 | G1 | 21 |
| | INT10_2 | | - | - | 112 |
| | INT11_1 | External interrupt request 11 input pin. | 17 | G2 | 22 |
| | INT11_2 | | - | - | 110 |
| | INT12_1 | External interrupt request 12 input pin. | 27 | J4 | 32 |
| | INT12_2 | | - | - | 108 |
| | INT13_1 | External interrupt request 13 input pin. | 28 | L5 | 33 |
| | INT13_2 | | - | - | 52 |
| INT14_1 | External interrupt request 14 input pin. | 39 | K6 | 44 | |
| INT14_2 | | - | - | 53 | |
| INT15_1 | External interrupt request 15 input pin. | 96 | C4 | 116 | |
| INT15_2 | | - | - | 54 | |
| NMIX | Non-Maskable Interrupt input. | 92 | B5 | 107 | |

| Module | Pin name | Function | Pin No. | | |
|--------|-----------------------------|-----------------------------|----------|---------|----------|
| | | | LQFP-100 | BGA-112 | LQFP-120 |
| GPIO | P00 | General-purpose I/O port 0. | 77 | A9 | 92 |
| | P01 | | 78 | B9 | 93 |
| | P02 | | 79 | B11 | 94 |
| | P03 | | 80 | A8 | 95 |
| | P04 | | 81 | B8 | 96 |
| | P05 | | 82 | C8 | 97 |
| | P06 | | 83 | D9 | 98 |
| | P07 | | 84 | A7 | 99 |
| | P08 | | 85 | B7 | 100 |
| | P09 | | 86 | C7 | 101 |
| | P0A | | 87 | D7 | 102 |
| | P0B | | 88 | A6 | 103 |
| | P0C | | 89 | B6 | 104 |
| | P0D | | 90 | C6 | 105 |
| | P0E | | 91 | A5 | 106 |
| | P0F | | 92 | B5 | 107 |
| | P10 | General-purpose I/O port 1. | 52 | J11 | 62 |
| | P11 | | 53 | J10 | 63 |
| | P12 | | 54 | J8 | 64 |
| | P13 | | 55 | H10 | 65 |
| | P14 | | 56 | H9 | 66 |
| | P15 | | 57 | H7 | 67 |
| | P16 | | 58 | G10 | 68 |
| | P17 | | 59 | G9 | 69 |
| | P18 | | 63 | G8 | 73 |
| | P19 | | 64 | F10 | 74 |
| | P1A | | 65 | F9 | 75 |
| | P1B | | 66 | E11 | 76 |
| P1C | 67 | E10 | 77 | | |
| P1D | 68 | F8 | 78 | | |
| P1E | 69 | E9 | 79 | | |
| P1F | 70 | D11 | 80 | | |
| P20 | General-purpose I/O port 2. | 74 | C10 | 89 | |
| P21 | | 73 | C11 | 88 | |
| P22 | | 72 | E8 | 87 | |
| P23 | | 71 | D10 | 86 | |
| P24 | | - | - | 85 | |
| P25 | | - | - | 84 | |
| P26 | | - | - | 83 | |
| P27 | | - | - | 82 | |
| P28 | - | - | 81 | | |

| Module | Pin name | Function | Pin No. | | | |
|--------|----------|-----------------------------|-----------------------------|---------|----------|----|
| | | | LQFP-100 | BGA-112 | LQFP-120 | |
| GPIO | P30 | General-purpose I/O port 3. | 9 | E1 | 14 | |
| | P31 | | 10 | E2 | 15 | |
| | P32 | | 11 | E3 | 16 | |
| | P33 | | 12 | E4 | 17 | |
| | P34 | | 13 | F1 | 18 | |
| | P35 | | 14 | F2 | 19 | |
| | P36 | | 15 | F3 | 20 | |
| | P37 | | 16 | G1 | 21 | |
| | P38 | | 17 | G2 | 22 | |
| | P39 | | 18 | F4 | 23 | |
| | P3A | | 19 | G3 | 24 | |
| | P3B | | 20 | H1 | 25 | |
| | P3C | | 21 | H2 | 26 | |
| | P3D | | 22 | G4 | 27 | |
| | P3E | | 23 | H3 | 28 | |
| | P3F | | 24 | J2 | 29 | |
| | P40 | | General-purpose I/O port 4. | 27 | J4 | 32 |
| | P41 | | | 28 | L5 | 33 |
| | P42 | | | 29 | K5 | 34 |
| | P43 | | | 30 | J5 | 35 |
| | P44 | | | 31 | H5 | 36 |
| | P45 | | | 32 | L6 | 37 |
| | P46 | | | 36 | L3 | 41 |
| | P47 | | | 37 | K3 | 42 |
| | P48 | 39 | | K6 | 44 | |
| | P49 | 40 | | J6 | 45 | |
| | P4A | 41 | | L7 | 46 | |
| | P4B | 42 | | K7 | 47 | |
| | P4C | 43 | | H6 | 48 | |
| | P4D | 44 | | J7 | 49 | |
| | P4E | 45 | | K8 | 50 | |
| | P50 | General-purpose I/O port 5. | | 2 | C1 | 2 |
| | P51 | | 3 | C2 | 3 | |
| | P52 | | 4 | B3 | 4 | |
| | P53 | | 5 | D1 | 5 | |
| | P54 | | 6 | D2 | 6 | |
| | P55 | | 7 | D3 | 7 | |
| | P56 | | 8 | D5 | 8 | |
| | P57 | | - | - | 9 | |
| | P58 | | - | - | 10 | |
| | P59 | | - | - | 11 | |
| | P5A | - | - | 12 | | |
| | P5B | - | - | 13 | | |

| Module | Pin name | Function | Pin No. | | |
|-------------------------|-----------------|--|---|---------|----------|
| | | | LQFP-100 | BGA-112 | LQFP-120 |
| GPIO | P60 | General-purpose I/O port 6. | 96 | C4 | 116 |
| | P61 | | 95 | B4 | 115 |
| | P62 | | 94 | C5 | 114 |
| | P63 | | 93 | D6 | 113 |
| | P64 | | - | - | 112 |
| | P65 | | - | - | 111 |
| | P66 | | - | - | 110 |
| | P67 | | - | - | 109 |
| | P68 | | - | - | 108 |
| | P70 | General-purpose I/O port 7. | - | - | 51 |
| | P71 | | - | - | 52 |
| | P72 | | - | - | 53 |
| | P73 | | - | - | 54 |
| | P74 | | - | - | 55 |
| | P80 | General-purpose I/O port 8. | 98 | A3 | 118 |
| P81 | 99 | | A2 | 119 | |
| Multi Function Serial 0 | SIN0_0 | Multifunction serial interface ch.0 input pin. | 73 | C11 | 88 |
| | SIN0_1 | | 56 | H9 | 66 |
| | SOT0_0 (SDA0_0) | Multifunction serial interface ch.0 output pin. This pin operates as SOT0 when it is used in a UART/CSIO/LIN (operation modes 0 to 3) and as SDA0 when it is used in an I ² C (operation mode 4). | 72 | E8 | 87 |
| | SOT0_1 (SDA0_1) | | 57 | H7 | 67 |
| | SCK0_0 (SCL0_0) | | Multifunction serial interface ch.0 clock I/O pin. This pin operates as SCK0 when it is used in a UART/CSIO (operation modes 0 to 2) and as SCL0 when it is used in an I ² C (operation mode 4). | 71 | D10 |
| SCK0_1 (SCL0_1) | 58 | G10 | | 68 | |
| Multi Function Serial 1 | SIN1_0 | Multifunction serial interface ch.1 input pin. | - | - | 8 |
| | SIN1_1 | | 53 | J10 | 63 |
| | SOT1_0 (SDA1_0) | Multifunction serial interface ch.1 output pin. This pin operates as SOT1 when it is used in a UART/CSIO/LIN (operation modes 0 to 3) and as SDA1 when it is used in an I ² C (operation mode 4). | - | - | 9 |
| | SOT1_1 (SDA1_1) | | 54 | J8 | 64 |
| | SCK1_0 (SCL1_0) | | Multifunction serial interface ch.1 clock I/O pin. This pin operates as SCK1 when it is used in a UART/CSIO (operation modes 0 to 2) and as SCL1 when it is used in an I ² C (operation mode 4). | - | - |
| SCK1_1 (SCL1_1) | 55 | H10 | | 65 | |
| Multi Function Serial 2 | SIN2_0 | Multifunction serial interface ch.2 input pin. | - | - | 53 |
| | SIN2_1 | | - | - | 85 |
| | SIN2_2 | | 59 | G9 | 69 |
| | SOT2_0 (SDA2_0) | Multifunction serial interface ch.2 output pin. This pin operates as SOT2 when it is used in a UART/CSIO/LIN (operation modes 0 to 3) and as SDA2 when it is used in an I ² C (operation mode 4). | - | - | 54 |
| | SOT2_1 (SDA2_1) | | - | - | 84 |
| | SOT2_2 (SDA2_2) | | 63 | G8 | 73 |
| | SCK2_0 (SCL2_0) | Multifunction serial interface ch.2 clock I/O pin. This pin operates as SCK2 when it is used in a UART/CSIO (operation modes 0 to 2) and as SCL2 when it is used in an I ² C (operation mode 4). | - | - | 55 |
| | SCK2_1 (SCL2_1) | | - | - | 83 |
| SCK2_2 (SCL2_2) | 64 | | F10 | 74 | |

| Module | Pin name | Function | Pin No. | | |
|-------------------------|-----------------|--|----------|---------|----------|
| | | | LQFP-100 | BGA-112 | LQFP-120 |
| Multi Function Serial 3 | SIN3_0 | Multifunction serial interface ch.3 input pin. | - | - | 110 |
| | SIN3_1 | | 2 | C1 | 2 |
| | SIN3_2 | | 39 | K6 | 44 |
| | SOT3_0 (SDA3_0) | Multifunction serial interface ch.3 output pin. This pin operates as SOT3 when it is used in a UART/CSIO/LIN (operation modes 0 to 3) and as SDA3 when it is used in an I ² C (operation mode 4). | - | - | 109 |
| | SOT3_1 (SDA3_1) | | 3 | C2 | 3 |
| | SOT3_2 (SDA3_2) | | 40 | J6 | 45 |
| | SCK3_0 (SCL3_0) | Multifunction serial interface ch.3 clock I/O pin. This pin operates as SCK3 when it is used in a UART/CSIO (operation modes 0 to 2) and as SCL3 when it is used in an I ² C (operation mode 4). | - | - | 108 |
| | SCK3_1 (SCL3_1) | | 4 | B3 | 4 |
| | SCK3_2 (SCL3_2) | | 41 | L7 | 46 |
| Multi Function Serial 4 | SIN4_0 | Multifunction serial interface ch.4 input pin. | 87 | D7 | 102 |
| | SIN4_1 | | 65 | F9 | 75 |
| | SIN4_2 | | 82 | C8 | 97 |
| | SOT4_0 (SDA4_0) | Multifunction serial interface ch.4 output pin. This pin operates as SOT4 when it is used in a UART/CSIO/LIN (operation modes 0 to 3) and as SDA4 when it is used in an I ² C (operation mode 4). | 88 | A6 | 103 |
| | SOT4_1 (SDA4_1) | | 66 | E11 | 76 |
| | SOT4_2 (SDA4_2) | | 83 | D9 | 98 |
| | SCK4_0 (SCL4_0) | Multifunction serial interface ch.4 clock I/O pin. This pin operates as SCK4 when it is used in a UART/CSIO (operation modes 0 to 2) and as SCL4 when it is used in an I ² C (operation mode 4). | 89 | B6 | 104 |
| | SCK4_1 (SCL4_1) | | 67 | E10 | 77 |
| | SCK4_2 (SCL4_2) | | 84 | A7 | 99 |
| | RTS4_0 | Multifunction serial interface ch.4 RTS output pin. | 90 | C6 | 105 |
| | RTS4_1 | | 69 | E9 | 79 |
| | RTS4_2 | | 86 | C7 | 101 |
| | CTS4_0 | Multifunction serial interface ch.4 CTS input pin. | 91 | A5 | 106 |
| | CTS4_1 | | 68 | F8 | 78 |
| | CTS4_2 | | 85 | B7 | 100 |
| Multi Function Serial 5 | SIN5_0 | Multifunction serial interface ch.5 input pin. | 96 | C4 | 116 |
| | SIN5_1 | | - | - | 113 |
| | SIN5_2 | | 15 | F3 | 20 |
| | SOT5_0 (SDA5_0) | Multifunction serial interface ch.5 output pin. This pin operates as SOT5 when it is used in a UART/CSIO/LIN (operation modes 0 to 3) and as SDA5 when it is used in an I ² C (operation mode 4). | 95 | B4 | 115 |
| | SOT5_1 (SDA5_1) | | - | - | 112 |
| | SOT5_2 (SDA5_2) | | 16 | G1 | 21 |
| | SCK5_0 (SCL5_0) | Multifunction serial interface ch.5 clock I/O pin. This pin operates as SCK5 when it is used in a UART/CSIO (operation modes 0 to 2) and as SCL5 when it is used in an I ² C (operation mode 4). | 94 | C5 | 114 |
| | SCK5_1 (SCL5_1) | | - | - | 111 |
| | SCK5_2 (SCL5_2) | | 17 | G2 | 22 |

| Module | Pin name | Function | Pin No. | | |
|-------------------------|-----------------|--|----------|---------|----------|
| | | | LQFP-100 | BGA-112 | LQFP-120 |
| Multi Function Serial 6 | SIN6_0 | Multifunction serial interface ch.6 input pin. | 5 | D1 | 5 |
| | SIN6_1 | | 12 | E4 | 17 |
| | SOT6_0 (SDA6_0) | Multifunction serial interface ch.6 output pin. This pin operates as SOT6 when it is used in a UART/CSIO/LIN (operation modes 0 to 3) and as SDA6 when it is used in an I ² C (operation mode 4). | 6 | D2 | 6 |
| | SOT6_1 (SDA6_1) | | 11 | E3 | 16 |
| | SCK6_0 (SCL6_0) | Multifunction serial interface ch.6 clock I/O pin. This pin operates as SCK6 when it is used in a UART/CSIO (operation modes 0 to 2) and as SCL6 when it is used in an I ² C (operation mode 4). | 7 | D3 | 7 |
| | SCK6_1 (SCL6_1) | | 10 | E2 | 15 |
| Multi Function Serial 7 | SIN7_0 | Multifunction serial interface ch.7 input pin. | - | - | 11 |
| | SIN7_1 | | 45 | K8 | 50 |
| | SOT7_0 (SDA7_0) | Multifunction serial interface ch.7 output pin. This pin operates as SOT7 when it is used in a UART/CSIO/LIN (operation modes 0 to 3) and as SDA7 when it is used in an I ² C (operation mode 4). | - | - | 12 |
| | SOT7_1 (SDA7_1) | | 44 | J7 | 49 |
| | SCK7_0 (SCL7_0) | Multifunction serial interface ch.7 clock I/O pin. This pin operates as SCK7 when it is used in a UART/CSIO (operation modes 0 to 2) and as SCL7 when it is used in an I ² C (operation mode 4). | - | - | 13 |
| | SCK7_1 (SCL7_1) | | 43 | H6 | 48 |

| Module | Pin name | Function | Pin No. | | | |
|------------------------|-------------------|---|---|---------|----------|----|
| | | | LQFP-100 | BGA-112 | LQFP-120 | |
| Multi Function Timer 0 | DTTI0X_0 | Input signal controlling wave form generator outputs RTO00 to RTO05 of multi-function timer 0. | 18 | F4 | 23 | |
| | DTTI0X_1 | | 69 | E9 | 79 | |
| | FRCK0_0 | 16-bit free-run timer ch.0 external clock input pin. | 13 | F1 | 18 | |
| | FRCK0_1 | | 70 | D11 | 80 | |
| | IC00_0 | 16-bit input capture ch.0 input pin of multi-function timer 0. ICxx describes channel number. | 17 | G2 | 22 | |
| | IC00_1 | | 65 | F9 | 75 | |
| | IC01_0 | | 16 | G1 | 21 | |
| | IC01_1 | | 66 | E11 | 76 | |
| | IC02_0 | | 15 | F3 | 20 | |
| | IC02_1 | | 67 | E10 | 77 | |
| | IC03_0 | | 14 | F2 | 19 | |
| | IC03_1 | | 68 | F8 | 78 | |
| | RTO00_0 (PPG00_0) | | Wave form generator output of multi-function timer 0. This pin operates as PPG00 when it is used in PPG 0 output modes. | 19 | G3 | 24 |
| | RTO00_1 (PPG00_1) | | | 71 | D10 | 86 |
| | RTO01_0 (PPG00_0) | Wave form generator output of multi-function timer 0. This pin operates as PPG00 when it is used in PPG 0 output modes. | 20 | H1 | 25 | |
| | RTO01_1 (PPG00_1) | | - | - | 85 | |
| | RTO02_0 (PPG02_0) | Wave form generator output of multi-function timer 0. This pin operates as PPG02 when it is used in PPG 0 output modes. | 21 | H2 | 26 | |
| | RTO02_1 (PPG02_1) | | - | - | 84 | |
| | RTO03_0 (PPG02_0) | Wave form generator output of multi-function timer 0. This pin operates as PPG02 when it is used in PPG 0 output modes. | 22 | G4 | 27 | |
| | RTO03_1 (PPG02_1) | | - | - | 83 | |
| | RTO04_0 (PPG04_0) | Wave form generator output of multi-function timer 0. This pin operates as PPG04 when it is used in PPG 0 output modes. | 23 | H3 | 28 | |
| | RTO04_1 (PPG04_1) | | - | - | 82 | |
| | RTO05_0 (PPG04_0) | Wave form generator output of multi-function timer 0. This pin operates as PPG04 when it is used in PPG 0 output modes. | 24 | J2 | 29 | |
| RTO05_1 (PPG04_1) | - | | - | 81 | | |

| Module | Pin name | Function | Pin No. | | |
|------------------------|-------------------|---|----------|---------|----------|
| | | | LQFP-100 | BGA-112 | LQFP-120 |
| Multi Function Timer 1 | DTT1X_0 | Input signal controlling wave form generator outputs RTO10 to RTO15 of multi-function timer 1. | 8 | D5 | 8 |
| | DTT1X_1 | | 39 | K6 | 44 |
| | FRCK1_0 | 16-bit free-run timer ch.1 external clock input pin. | 87 | D7 | 102 |
| | FRCK1_1 | | 44 | J7 | 49 |
| | IC10_0 | 16-bit input capture ch.0 input pin of multi-function timer 1. ICxx describes channel number. | 88 | A6 | 103 |
| | IC10_1 | | 40 | J6 | 45 |
| | IC11_0 | | 89 | B6 | 104 |
| | IC11_1 | | 41 | L7 | 46 |
| | IC12_0 | | 90 | C6 | 105 |
| | IC12_1 | | 42 | K7 | 47 |
| | IC13_0 | | 91 | A5 | 106 |
| | IC13_1 | | 43 | H6 | 48 |
| | RTO10_0 (PPG10_0) | Wave form generator output of multi-function timer 1. This pin operates as PPG10 when it is used in PPG 1 output modes. | 2 | C1 | 2 |
| | RTO10_1 (PPG10_1) | | 27 | J4 | 32 |
| | RTO11_0 (PPG10_0) | Wave form generator output of multi-function timer 1. This pin operates as PPG10 when it is used in PPG 1 output modes. | 3 | C2 | 3 |
| | RTO11_1 (PPG10_1) | | 28 | L5 | 33 |
| | RTO12_0 (PPG12_0) | Wave form generator output of multi-function timer 1. This pin operates as PPG12 when it is used in PPG 1 output modes. | 4 | B3 | 4 |
| | RTO12_1 (PPG12_1) | | 29 | K5 | 34 |
| | RTO13_0 (PPG12_0) | Wave form generator output of multi-function timer 1. This pin operates as PPG12 when it is used in PPG 1 output modes. | 5 | D1 | 5 |
| | RTO13_1 (PPG12_1) | | 30 | J5 | 35 |
| | RTO14_0 (PPG14_0) | Wave form generator output of multi-function timer 1. This pin operates as PPG14 when it is used in PPG 1 output modes. | 6 | D2 | 6 |
| | RTO14_1 (PPG14_1) | | 31 | H5 | 36 |
| | RTO15_0 (PPG14_0) | Wave form generator output of multi-function timer 1. This pin operates as PPG14 when it is used in PPG 1 output modes. | 7 | D3 | 7 |
| RTO15_1 (PPG14_1) | 32 | | L6 | 37 | |

| Module | Pin name | Function | Pin No. | | |
|---|----------|-----------------------------------|----------|---------|----------|
| | | | LQFP-100 | BGA-112 | LQFP-120 |
| Quadrature Position/ Revolution Counter 0 | AIN0_0 | QPRC ch.0 AIN input pin. | 9 | E1 | 14 |
| | AIN0_1 | | 40 | J6 | 45 |
| | AIN0_2 | | 2 | C1 | 2 |
| | BIN0_0 | QPRC ch.0 BIN input pin. | 10 | E2 | 15 |
| | BIN0_1 | | 41 | L7 | 46 |
| | BIN0_2 | | 3 | C2 | 3 |
| | ZIN0_0 | QPRC ch.0 ZIN input pin. | 11 | E3 | 16 |
| | ZIN0_1 | | 42 | K7 | 47 |
| | ZIN0_2 | | 4 | B3 | 4 |
| Quadrature Position/ Revolution Counter 1 | AIN1_1 | QPRC ch.1 AIN input pin. | 74 | C10 | 89 |
| | AIN1_2 | | 43 | H6 | 48 |
| | BIN1_1 | QPRC ch.1 BIN input pin. | 73 | C11 | 88 |
| | BIN1_2 | | 44 | J7 | 49 |
| | ZIN1_1 | QPRC ch.1 ZIN input pin. | 72 | E8 | 87 |
| | ZIN1_2 | | 45 | K8 | 50 |
| USB | UDM0 | USB Device / HOST D – pin. | 98 | A3 | 118 |
| | UDP0 | USB Device / HOST D + pin. | 99 | A2 | 119 |
| | UHCONX | USB external pull-up control pin. | 95 | B4 | 115 |

| Module | Pin name | Function | Pin No. | | |
|--------------|----------|--|----------|---------|----------|
| | | | LQFP-100 | BGA-112 | LQFP-120 |
| Reset | INITX | External Reset Input. A reset is valid when INITX=L. | 38 | K4 | 43 |
| Mode | MD0 | Mode 0 pin. During normal operation, MD0=L must be input. During serial programming to flash memory, MD0=H must be input. | 47 | L8 | 57 |
| | MD1 | Mode 1 pin. Input must always be at the "L" level. | 46 | K9 | 56 |
| Power | VCC | Power Pin. | 1 | B1 | 1 |
| | VCC | | 26 | J1 | 31 |
| | VCC | | 35 | K1 | 40 |
| | VCC | | 51 | K11 | 61 |
| | VCC | | 76 | A10 | 91 |
| | USBVCC | 3.3V Power supply port for USB I/O. | 97 | A4 | 117 |
| GND | VSS | GND Pin. | - | B2 | - |
| | VSS | | 25 | L1 | 30 |
| | VSS | | - | K2 | - |
| | VSS | | - | J3 | - |
| | VSS | | - | H4 | - |
| | VSS | | 34 | L4 | 39 |
| | VSS | | 50 | L11 | 60 |
| | VSS | | - | K10 | - |
| | VSS | | - | J9 | - |
| | VSS | | - | H8 | - |
| | VSS | | - | B10 | - |
| | VSS | | - | C9 | - |
| | VSS | | 75 | A11 | 90 |
| | VSS | | - | D8 | - |
| | VSS | | - | D4 | - |
| | VSS | | - | C3 | - |
| | VSS | | 100 | A1 | 120 |
| Clock | X0 | Main clock (oscillation) input pin. | 48 | L9 | 58 |
| | X0A | Sub clock (oscillation) input pin. | 36 | L3 | 41 |
| | X1 | Main clock (oscillation) I/O pin. | 49 | L10 | 59 |
| | X1A | Sub clock (oscillation) I/O pin. | 37 | K3 | 42 |
| | CROUT | Built-in High-speed CR-osc clock output port. | 74 | C10 | 89 |
| Analog Power | AVCC | A/D converter analog power pin. | 60 | H11 | 70 |
| | AVRH | A/D converter analog reference voltage input pin. | 61 | F11 | 71 |
| Analog GND | AVSS | A/D converter GND pin. | 62 | G11 | 72 |
| C-pin | C | Power stabilization capacity pin. | 33 | L2 | 38 |

Note:

- While this device contains a Test Access Port (TAP) based on the IEEE 1149.1-2001 JTAG standard, it is not fully compliant to all requirements of that standard. This device may contain a 32-bit device ID that is the same as the 32-bit device ID in other devices with different functionality. The TAP pins may also be configurable for purposes other than access to the TAP controller.

5. I/O Circuit Type

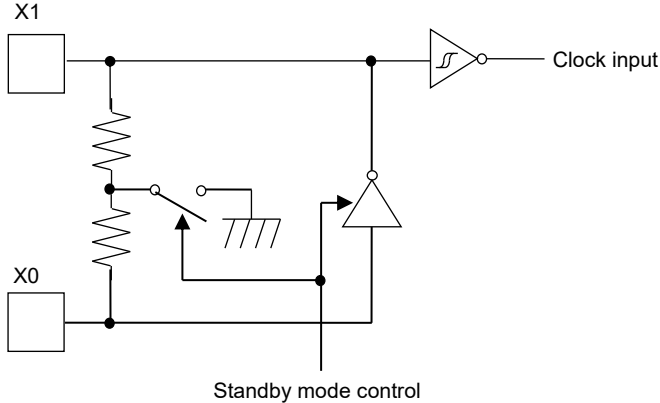
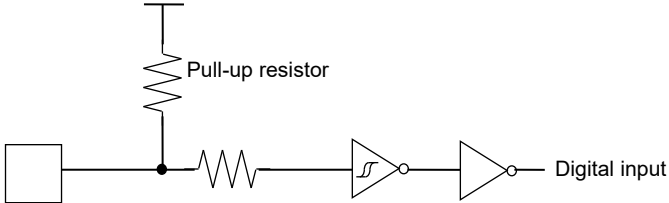
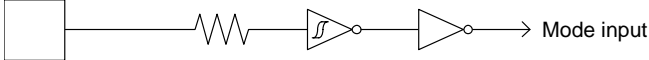
| Type | Circuit | Remarks |
|------|---|---|
| A |  | <ul style="list-style-type: none"> • Oscillation feedback resistor : Approximately 1 MΩ • With Standby mode control |
| B |  | <ul style="list-style-type: none"> • CMOS level hysteresis input • pull-up resistor : Approximately 50 kΩ |
| C |  | <ul style="list-style-type: none"> • CMOS level hysteresis input |

| Type | Circuit | Remarks |
|------|---|--|
| D | <p>The diagram shows two oscillator sections, X1A and X0A. Each section consists of an oscillator core (represented by a square) connected to a network of resistors (R) and transistors (P-ch and N-ch). The X1A section includes a pull-up resistor and a feedback resistor. The X0A section also includes a pull-up resistor. Various digital outputs are shown, including P-ch and N-ch outputs. Digital inputs are connected to the oscillator nodes. Standby mode control signals are connected to the oscillator nodes. A clock input is connected to the oscillator nodes. The circuit is designed to provide a stable digital signal for the oscillator.</p> | <p>It is possible to select the sub oscillation / GPIO function</p> <p>When the sub oscillation is selected.</p> <ul style="list-style-type: none"> • Oscillation feedback resistor : Approximately 20 MΩ • With Standby mode control <p>When the GPIO is selected.</p> <ul style="list-style-type: none"> • CMOS level output. • CMOS level hysteresis input • With pull-up resistor control • With standby mode control • pull-up resistor : Approximately 50 kΩ • I_{OH} = -4 mA, I_{OL} = 4 mA |

| Type | Circuit | Remarks |
|------|---------|--|
| E | | <ul style="list-style-type: none"> • CMOS level output • CMOS level hysteresis input • With pull-up resistor control • With standby mode control • pull-up resistor : Approximately 50 kΩ • $I_{OH} = -4 \text{ mA}$, $I_{OL} = 4 \text{ mA}$ • When this pin is used as an I²C pin, the digital output P-ch transistor is always off • +B input is available |
| F | | <ul style="list-style-type: none"> • CMOS level output • CMOS level hysteresis input • With input control • Analog input • With pull-up resistor control • With standby mode control • pull-up resistor : Approximately 50 kΩ • $I_{OH} = -4 \text{ mA}$, $I_{OL} = 4 \text{ mA}$ • When this pin is used as an I²C pin, the digital output P-ch transistor is always off • +B input is available |

| Type | Circuit | Remarks |
|------|---|--|
| G | <p>The diagram shows a CMOS output stage. A pull-up resistor 'R' is connected to the output node. The output node is driven by a P-channel MOSFET (P-ch) and an N-channel MOSFET (N-ch). The P-ch MOSFET gate is connected to a 'Pull-up resistor control' signal. The N-ch MOSFET gate is connected to a 'Standby mode control' signal. The output node is also connected to a 'Digital input' through an inverter and a 'Digital output' terminal.</p> | <ul style="list-style-type: none"> • CMOS level output • CMOS level hysteresis input • With pull-up resistor control • With standby mode control • pull-up resistor : Approximately 50 kΩ • $I_{OH} = -12 \text{ mA}$, $I_{OL} = 12 \text{ mA}$ • +B input is available |
| H | <p>The diagram shows a complex digital I/O circuit. It includes several input and output buffers, inverters, and logic gates. Key components include: <ul style="list-style-type: none"> UDP0/P81 and UDM0/P80 input buffers. Differential input and output drivers. GPIO Digital input/output direction control logic. GPIO Digital input circuit control logic. USB Digital input/output direction control logic. GPIO Digital output drivers. </p> | <p>It is possible to select the USB IO / GPIO function.</p> <p>When the USB IO is selected.</p> <ul style="list-style-type: none"> • Full-speed, Low-speed control <p>When the GPIO is selected.</p> <ul style="list-style-type: none"> • CMOS level output • CMOS level hysteresis input • With standby mode control • $I_{OH} = -25.3 \text{ mA}$, $I_{OL} = 19.7 \text{ mA}$ |

6. Handling Precautions

Any semiconductor devices have inherently a certain rate of failure. The possibility of failure is greatly affected by the conditions in which they are used (circuit conditions, environmental conditions, etc.). This page describes precautions that must be observed to minimize the chance of failure and to obtain higher reliability from your Cypress semiconductor devices.

6.1 Precautions for Product Design

This section describes precautions when designing electronic equipment using semiconductor devices.

Absolute Maximum Ratings

Semiconductor devices can be permanently damaged by application of stress (voltage, current, temperature, etc.) in excess of certain established limits, called absolute maximum ratings. Do not exceed these ratings.

Recommended Operating Conditions

Recommended operating conditions are normal operating ranges for the semiconductor device. All the device's electrical characteristics are warranted when operated within these ranges.

Always use semiconductor devices within the recommended operating conditions. Operation outside these ranges may adversely affect reliability and could result in device failure.

No warranty is made with respect to uses, operating conditions, or combinations not represented on the datasheet. Users considering application outside the listed conditions are advised to contact their sales representative beforehand.

Processing and Protection of Pins

These precautions must be followed when handling the pins which connect semiconductor devices to power supply and input/output functions.

1. Preventing Over-Voltage and Over-Current Conditions
Exposure to voltage or current levels in excess of maximum ratings at any pin is likely to cause deterioration within the device, and in extreme cases leads to permanent damage of the device. Try to prevent such overvoltage or over-current conditions at the design stage.
2. Protection of Output Pins
Shorting of output pins to supply pins or other output pins, or connection to large capacitance can cause large current flows. Such conditions if present for extended periods of time can damage the device. Therefore, avoid this type of connection.
3. Handling of Unused Input Pins
Unconnected input pins with very high impedance levels can adversely affect stability of operation. Such pins should be connected through an appropriate resistance to a power supply pin or ground pin.

Latch-up

Semiconductor devices are constructed by the formation of P-type and N-type areas on a substrate. When subjected to abnormally high voltages, internal parasitic PNP junctions (called thyristor structures) may be formed, causing large current levels in excess of several hundred mA to flow continuously at the power supply pin. This condition is called latch-up.

CAUTION: The occurrence of latch-up not only causes loss of reliability in the semiconductor device, but can cause injury or damage from high heat, smoke or flame. To prevent this from happening, do the following:

1. Be sure that voltages applied to pins do not exceed the absolute maximum ratings. This should include attention to abnormal noise, surge levels, etc.
2. Be sure that abnormal current flows do not occur during the power-on sequence.

Observance of Safety Regulations and Standards

Most countries in the world have established standards and regulations regarding safety, protection from electromagnetic interference, etc. Customers are requested to observe applicable regulations and standards in the design of products.

Fail-Safe Design

Any semiconductor devices have inherently a certain rate of failure. You must protect against injury, damage or loss from such failures by incorporating safety design measures into your facility and equipment such as redundancy, fire protection, and prevention of over-current levels and other abnormal operating conditions.

Precautions Related to Usage of Devices

Cypress semiconductor devices are intended for use in standard applications (computers, office automation and other office equipment, industrial, communications, and measurement equipment, personal or household devices, etc.).

CAUTION: Customers considering the use of our products in special applications where failure or abnormal operation may directly affect human lives or cause physical injury or property damage, or where extremely high levels of reliability are demanded (such as aerospace systems, atomic energy controls, sea floor repeaters, vehicle operating controls, medical devices for life support, etc.) are requested to consult with sales representatives before such use. The company will not be responsible for damages arising from such use without prior approval.

6.2 Precautions for Package Mounting

Package mounting may be either lead insertion type or surface mount type. In either case, for heat resistance during soldering, you should only mount under Cypress recommended conditions. For detailed information about mount conditions, contact your sales representative.

Lead Insertion Type

Mounting of lead insertion type packages onto printed circuit boards may be done by two methods: direct soldering on the board, or mounting by using a socket.

Direct mounting onto boards normally involves processes for inserting leads into through-holes on the board and using the flow soldering (wave soldering) method of applying liquid solder. In this case, the soldering process usually causes leads to be subjected to thermal stress in excess of the absolute ratings for storage temperature. Mounting processes should conform to Cypress recommended mounting conditions.

If socket mounting is used, differences in surface treatment of the socket contacts and IC lead surfaces can lead to contact deterioration after long periods. For this reason it is recommended that the surface treatment of socket contacts and IC leads be verified before mounting.

Surface Mount Type

Surface mount packaging has longer and thinner leads than lead-insertion packaging, and therefore leads are more easily deformed or bent. The use of packages with higher pin counts and narrower pin pitch results in increased susceptibility to open connections caused by deformed pins, or shorting due to solder bridges.

You must use appropriate mounting techniques. Cypress recommends the solder reflow method, and has established a ranking of mounting conditions for each product. Users are advised to mount packages in accordance with Cypress ranking of recommended conditions.

Lead-Free Packaging

CAUTION: When ball grid array (BGA) packages with Sn-Ag-Cu balls are mounted using Sn-Pb eutectic soldering, junction strength may be reduced under some conditions of use.

Storage of Semiconductor Devices

Because plastic chip packages are formed from plastic resins, exposure to natural environmental conditions will cause absorption of moisture. During mounting, the application of heat to a package that has absorbed moisture can cause surfaces to peel, reducing moisture resistance and causing packages to crack. To prevent, do the following:

1. Avoid exposure to rapid temperature changes, which cause moisture to condense inside the product. Store products in locations where temperature changes are slight.
2. Use dry boxes for product storage. Products should be stored below 70% relative humidity, and at temperatures between 5°C and 30°C.
When you open Dry Package that recommends humidity 40% to 70% relative humidity.
3. When necessary, Cypress packages semiconductor devices in highly moisture-resistant aluminum laminate bags, with a silica gel desiccant. Devices should be sealed in their aluminum laminate bags for storage.
4. Avoid storing packages where they are exposed to corrosive gases or high levels of dust.

Baking

Packages that have absorbed moisture may be de-moisturized by baking (heat drying). Follow the Cypress recommended conditions for baking.

Condition: 125°C/24 h

Static Electricity

Because semiconductor devices are particularly susceptible to damage by static electricity, you must take the following precautions:

1. Maintain relative humidity in the working environment between 40% and 70%. Use of an apparatus for ion generation may be needed to remove electricity.
2. Electrically ground all conveyors, solder vessels, soldering irons and peripheral equipment.
3. Eliminate static body electricity by the use of rings or bracelets connected to ground through high resistance (on the level of 1 MΩ).
Wearing of conductive clothing and shoes, use of conductive floor mats and other measures to minimize shock loads is recommended.
4. Ground all fixtures and instruments, or protect with anti-static measures.
5. Avoid the use of styrofoam or other highly static-prone materials for storage of completed board assemblies.

6.3 Precautions for Use Environment

Reliability of semiconductor devices depends on ambient temperature and other conditions as described above.

For reliable performance, do the following:

1. Humidity
Prolonged use in high humidity can lead to leakage in devices as well as printed circuit boards. If high humidity levels are anticipated, consider anti-humidity processing.
2. Discharge of Static Electricity
When high-voltage charges exist close to semiconductor devices, discharges can cause abnormal operation. In such cases, use anti-static measures or processing to prevent discharges.
3. Corrosive Gases, Dust, or Oil
Exposure to corrosive gases or contact with dust or oil may lead to chemical reactions that will adversely affect the device. If you use devices in such conditions, consider ways to prevent such exposure or to protect the devices.
4. Radiation, Including Cosmic Radiation
Most devices are not designed for environments involving exposure to radiation or cosmic radiation. Users should provide shielding as appropriate.
5. Smoke, Flame
CAUTION: Plastic molded devices are flammable, and therefore should not be used near combustible substances. If devices begin to smoke or burn, there is danger of the release of toxic gases.

Customers considering the use of Cypress products in other special environmental conditions should consult with sales representatives.

7. Handling Devices

Power supply pins

In products with multiple VCC and VSS pins, respective pins at the same potential are interconnected within the device in order to prevent malfunctions such as latch-up. However, all of these pins should be connected externally to the power supply or ground lines in order to reduce electromagnetic emission levels, to prevent abnormal operation of strobe signals caused by the rise in the ground level, and to conform to the total output current rating.

Moreover, connect the current supply source with each Power supply pin and GND pin of this device at low impedance. It is also advisable that a ceramic capacitor of approximately 0.1 μF be connected as a bypass capacitor between each Power supply pin and GND pin, between AVCC pin and AVSS pin near this device.

Stabilizing power supply voltage

A malfunction may occur when the power supply voltage fluctuates rapidly even though the fluctuation is within the recommended operating conditions of the VCC power supply voltage. As a rule, with voltage stabilization, suppress the voltage fluctuation so that the fluctuation in VCC ripple (peak-to-peak value) at the commercial frequency (50 Hz/60 Hz) does not exceed 10% of the VCC value in the recommended operating conditions, and the transient fluctuation rate does not exceed 0.1 V/ μs when there is a momentary fluctuation on switching the power supply.

Crystal oscillator circuit

Noise near the X0/X1 and X0A/X1A pins may cause the device to malfunction. Design the printed circuit board so that X0/X1, X0A/X1A pins, the crystal oscillator (or ceramic oscillator), and the bypass capacitor to ground are located as close to the device as possible.

It is strongly recommended that the PC board artwork be designed such that the X0/X1 and X0A/X1A pins are surrounded by ground plane as this is expected to produce stable operation.

Evaluate oscillation of your using crystal oscillator by your mount board.

Using an external clock

When using an external clock, the clock signal should be input to the X0,X0A pin only and the X1,X1A pin should be kept open.

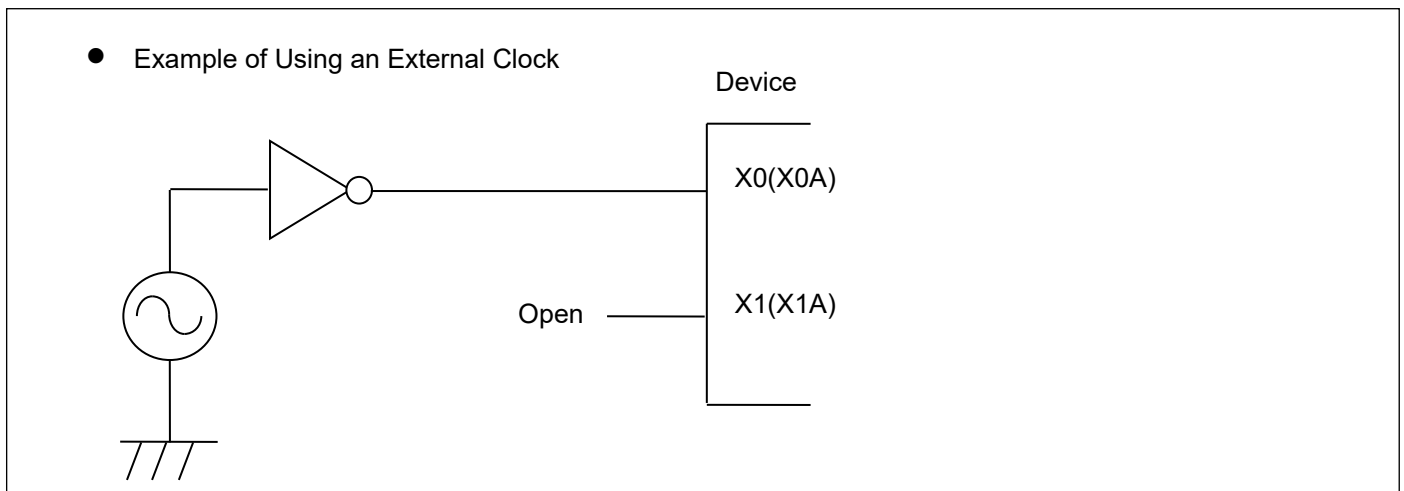

Handling when using Multi function serial pin as I²C pin

If it is using multi function serial pin as I²C pins, P-ch transistor of digital output is always disable. However, I²C pins need to keep the electrical characteristic like other pins and not to connect to external I²C bus system with power OFF.

C Pin

This series contains the regulator. Be sure to connect a smoothing capacitor (C_s) for the regulator between the C pin and the GND pin. Please use a ceramic capacitor or a capacitor of equivalent frequency characteristics as a smoothing capacitor. However, some laminated ceramic capacitors have the characteristics of capacitance variation due to thermal fluctuation (F characteristics and Y5V characteristics). Please select the capacitor that meets the specifications in the operating conditions to use by evaluating the temperature characteristics of a capacitor. A smoothing capacitor of about 4.7 μF would be recommended for this series.

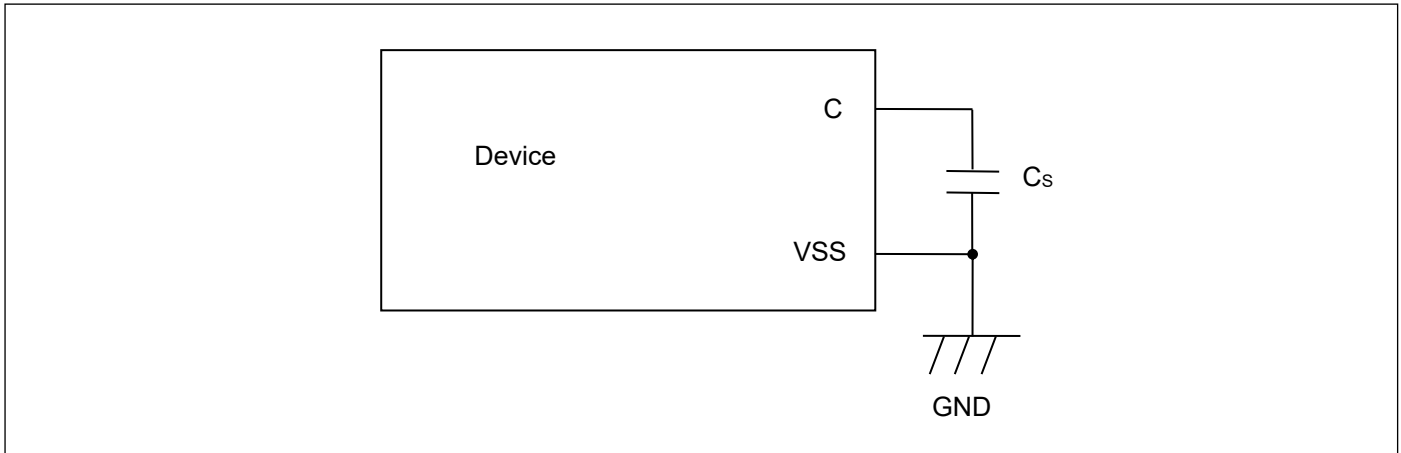

Mode pins (MD0, MD1)

Connect the MD pin (MD0, MD1) directly to VCC or VSS pins. Design the printed circuit board such that the pull-up/down resistance stays low, as well as the distance between the mode pins and VCC pins or VSS pins is as short as possible and the connection impedance is low, when the pins are pulled-up/down such as for switching the pin level and rewriting the Flash memory data. It is because of preventing the device erroneously switching to test mode due to noise.

Notes on power-on

Turn power on/off in the following order or at the same time.
 If not using the A/D converter, connect AVCC =VCC and AVSS = VSS.

- Turning on : VCC → USBVCC
- VCC → AVCC → AVRH
- Turning off : AVRH → AVCC → VCC
- USBVCC → VCC

Serial Communication

There is a possibility to receive wrong data due to the noise or other causes on the serial communication. Therefore, design a printed circuit board so as to avoid noise. Consider the case of receiving wrong data due to noise, perform error detection such as by applying a checksum of data at the end. If an error is detected, retransmit the data.

Differences in features among the products with different memory sizes and between FLASH products and MASK products

The electric characteristics including power consumption, ESD, latch-up, noise characteristics, and oscillation characteristics among the products with different memory sizes and between FLASH products and MASK products are different because chip layout and memory structures are different.

If you are switching to use a different product of the same series, please make sure to evaluate the electric characteristics.

8. Block Diagram

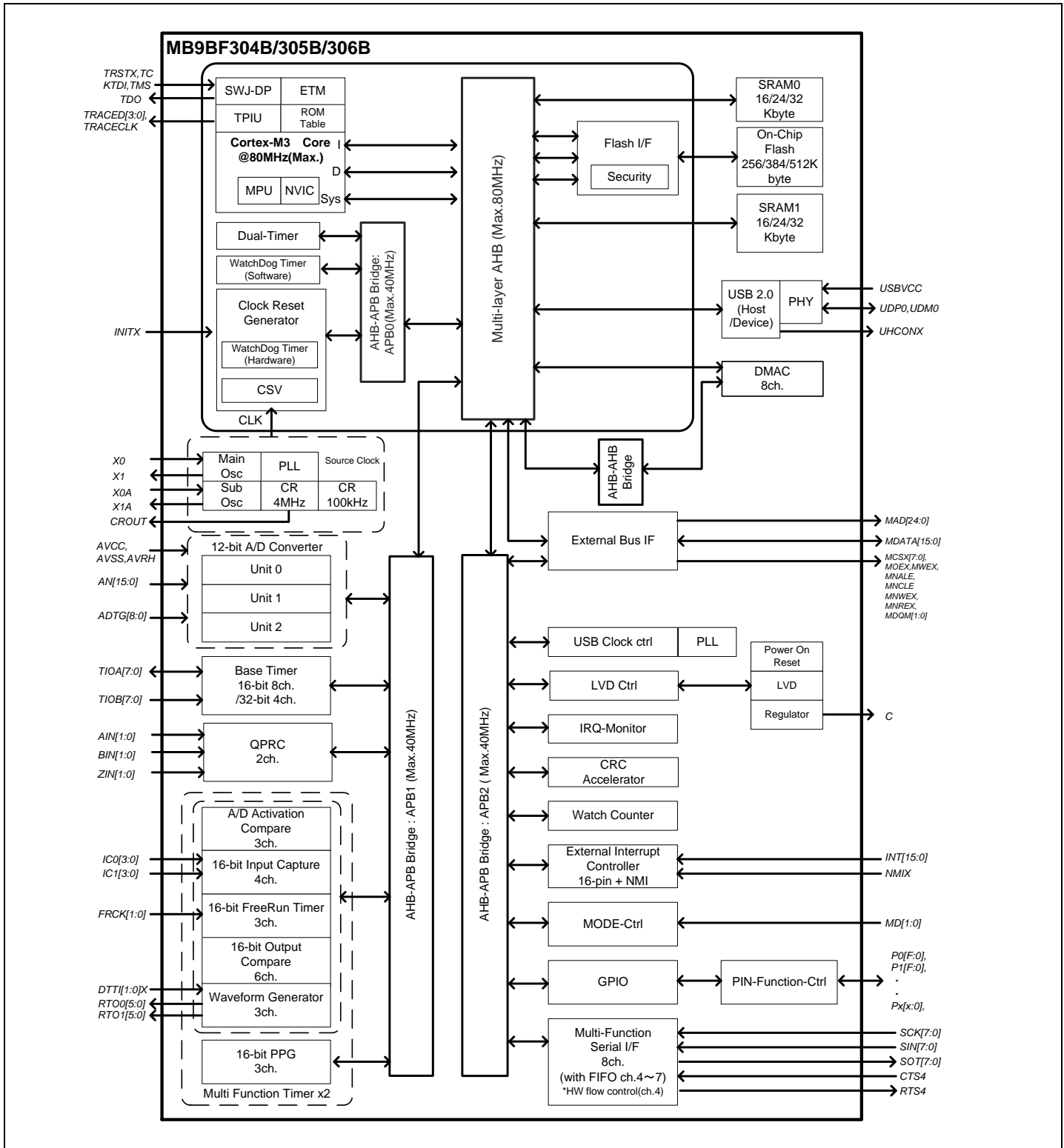

9. Memory Size

See "Memory size" in "1. Product Lineup" to confirm the memory size.

10. Memory Map

Memory Map (1)

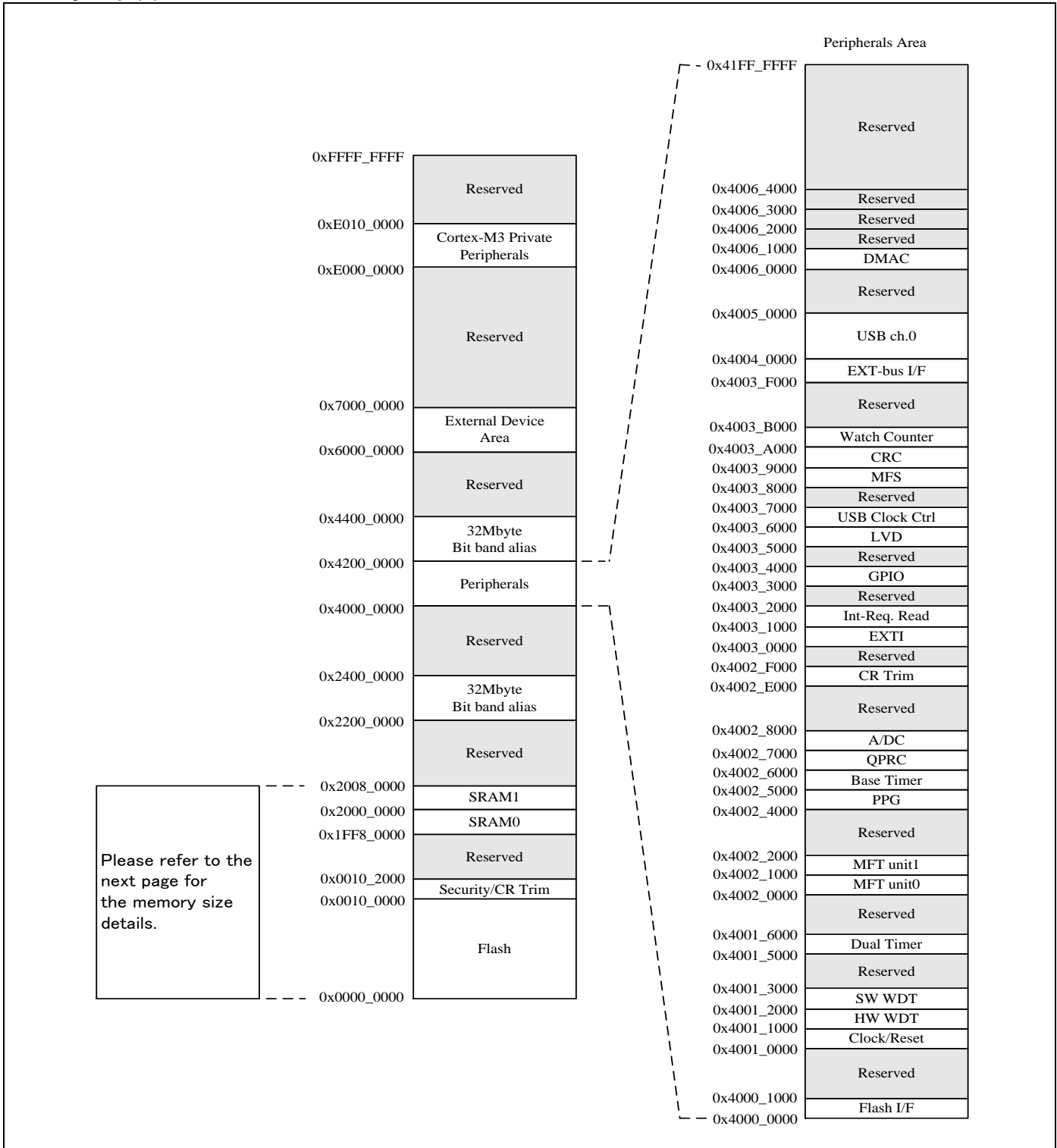

Memory Map (2)

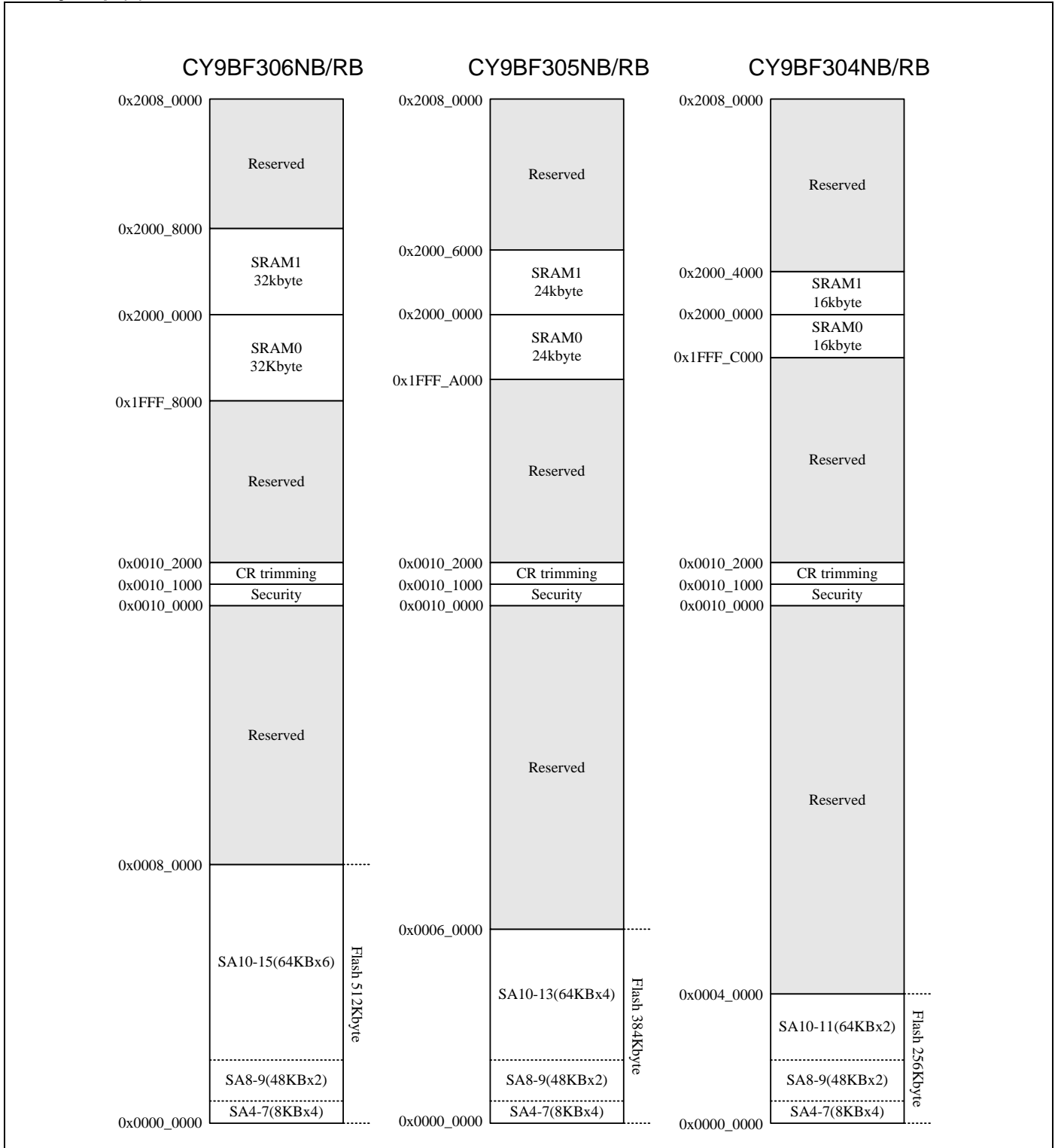

*: See "CY9B500/400/300/100/CY9A100 Series Flash Programming Manual" for sector structure of Flash.

Peripheral Address Map

| Start address | End address | Bus | Peripherals |
|---------------|-------------|--|---------------------------------------|
| 0x4000_0000 | 0x4000_0FFF | AHB | Flash Memory I/F register |
| 0x4000_1000 | 0x4000_FFFF | | Reserved |
| 0x4001_0000 | 0x4001_0FFF | APB0 | Clock/Reset Control |
| 0x4001_1000 | 0x4001_1FFF | | Hardware Watchdog timer |
| 0x4001_2000 | 0x4001_2FFF | | Software Watchdog timer |
| 0x4001_3000 | 0x4001_4FFF | | Reserved |
| 0x4001_5000 | 0x4001_5FFF | | Dual-Timer |
| 0x4001_6000 | 0x4001_FFFF | | Reserved |
| 0x4002_0000 | 0x4002_0FFF | | APB1 |
| 0x4002_1000 | 0x4002_1FFF | Multi-function timer unit1 | |
| 0x4002_2000 | 0x4002_3FFF | Reserved | |
| 0x4002_4000 | 0x4002_4FFF | PPG | |
| 0x4002_5000 | 0x4002_5FFF | Base Timer | |
| 0x4002_6000 | 0x4002_6FFF | Quadrature Position/Revolution Counter | |
| 0x4002_7000 | 0x4002_7FFF | A/D Converter | |
| 0x4002_8000 | 0x4002_DFFF | Reserved | |
| 0x4002_E000 | 0x4002_EFFF | Internal CR trimming | |
| 0x4002_F000 | 0x4002_FFFF | Reserved | |
| 0x4003_0000 | 0x4003_0FFF | APB2 | |
| 0x4003_1000 | 0x4003_1FFF | | Interrupt Request Batch-Read Function |
| 0x4003_2000 | 0x4003_2FFF | | Reserved |
| 0x4003_3000 | 0x4003_3FFF | | GPIO |
| 0x4003_4000 | 0x4003_4FFF | | Reserved |
| 0x4003_5000 | 0x4003_5FFF | | Low Voltage Detector |
| 0x4003_6000 | 0x4003_6FFF | | USB clock generator |
| 0x4003_7000 | 0x4003_7FFF | | Reserved |
| 0x4003_8000 | 0x4003_8FFF | | Multi-function serial Interface |
| 0x4003_9000 | 0x4003_9FFF | | CRC |
| 0x4003_A000 | 0x4003_AFFF | | Watch Counter |
| 0x4003_B000 | 0x4003_EFFF | | Reserved |
| 0x4003_F000 | 0x4003_FFFF | | External Memory interface |
| 0x4004_0000 | 0x4004_FFFF | AHB | USB ch.0 |
| 0x4005_0000 | 0x4005_FFFF | | Reserved |
| 0x4006_0000 | 0x4006_0FFF | | DMAC register |
| 0x4006_1000 | 0x4006_1FFF | | Reserved |
| 0x4006_2000 | 0x4006_2FFF | | Reserved |
| 0x4006_3000 | 0x4006_3FFF | | Reserved |
| 0x4006_4000 | 0x41FF_FFFF | | Reserved |

11. Pin Status in Each CPU State

The terms used for pin status have the following meanings.

■ **INITX=0**

This is the period when the INITX pin is the "L" level.

■ **INITX=1**

This is the period when the INITX pin is the "H" level.

■ **SPL=0**

This is the status that standby pin level setting bit (SPL) in standby mode control register (STB_CTL) is set to "0".

■ **SPL=1**

This is the status that standby pin level setting bit (SPL) in standby mode control register (STB_CTL) is set to "1".

■ **Input enabled**

Indicates that the input function can be used.

■ **Internal input fixed at "0"**

This is the status that the input function cannot be used. Internal input is fixed at "L".

■ **Hi-Z**

Indicates that the output drive transistor is disabled and the pin is put in the Hi-Z state.

■ **Setting disabled**

Indicates that the setting is disabled.

■ **Maintain previous state**

Maintains the state that was immediately prior to entering the current mode.
If a built-in peripheral function is operating, the output follows the peripheral function.
If the pin is being used as a port, that output is maintained.

■ **Analog input is enabled**

Indicates that the analog input is enabled.

■ **Trace output**

Indicates that the trace function can be used.

List of Pin Status

| Pin status type | Function group | Power-on reset or low voltage detection state | INITX input state | Device internal reset state | Run mode or sleep mode state | Timer mode or sleep mode state | |
|-----------------|--|--|--|--|---|---|---|
| | | Power supply unstable | Power supply stable | | Power supply stable | Power supply stable | |
| | | - | INITX=0 | INITX=1 | INITX=1 | INITX=1 | |
| | | - | - | - | - | SPL=0 | SPL=1 |
| A | Main crystal oscillator input pin | Input enabled | Input enabled | Input enabled | Input enabled | Input enabled | Input enabled |
| B | Main crystal oscillator output pin | H output/ Internal input fixed at "0"/ or Input enabled | H output/ Internal input fixed at "0" | H output/ Internal input fixed at "0" | Maintain previous state/ H output at oscillation stop ^{*1} / Internal input fixed at "0" | Maintain previous state/ H output at oscillation stop ^{*1} / Internal input fixed at "0" | Maintain previous state/ H output at oscillation stop ^{*1} / Internal input fixed at "0" |
| C | INITX input pin | Pull-up/ Input enabled | Pull-up/ Input enabled | Pull-up/ Input enabled | Pull-up/ Input enabled | Pull-up/ Input enabled | Pull-up/ Input enabled |
| D | Mode input pin | Input enabled | Input enabled | Input enabled | Input enabled | Input enabled | Input enabled |
| E | JTAG selected | Hi-Z | Pull-up/ Input enabled | Pull-up/ Input enabled | Maintain previous state | Maintain previous state | Maintain previous state |
| | GPIO selected | Setting disabled | Setting disabled | Setting disabled | | | Hi-Z/ Internal input fixed at "0" |
| F | Trace selected | Setting disabled | Setting disabled | Setting disabled | Maintain previous state | Maintain previous state | Trace output |
| | External interrupt enabled selected | | | | | | Maintain previous state |
| | GPIO selected, or other than above resource selected | Hi-Z | Hi-Z/ Input enabled | Hi-Z/ Input enabled | | | Hi-Z/ Internal input fixed at "0" |
| G | Trace selected | Setting disabled | Setting disabled | Setting disabled | Maintain previous state | Maintain previous state | Trace output |
| | GPIO selected, or other than above resource selected | Hi-Z | Hi-Z/ Input enabled | Hi-Z/ Input enabled | | | Hi-Z/ Internal input fixed at "0" |
| H | External interrupt enabled selected | Setting disabled | Setting disabled | Setting disabled | Maintain previous state | Maintain previous state | Maintain previous state |
| | GPIO selected, or other than above resource selected | Hi-Z | Hi-Z/ Input enabled | Hi-Z/ Input enabled | | | Hi-Z/ Internal input fixed at "0" |

| Pin status type | Function group | Power-on reset or low voltage detection state | INITX input state | Device internal reset state | Run mode or sleep mode state | Timer mode or sleep mode state | |
|-----------------|--|---|---|---|---|---|---|
| | | Power supply unstable | Power supply stable | | Power supply stable | Power supply stable | |
| | | - | INITX=0 | INITX=1 | INITX=1 | INITX=1 | |
| | | - | - | - | - | SPL=0 | SPL=1 |
| I | GPIO selected, resource selected | Hi-Z | Hi-Z/ Input enabled | Hi-Z/ Input enabled | Maintain previous state | Maintain previous state | Hi-Z/ Internal input fixed at "0" |
| J | NMIX selected | Setting disabled | Setting disabled | Setting disabled | Maintain previous state | Maintain previous state | Maintain previous state |
| | GPIO selected, or other than above resource selected | Hi-Z | Hi-Z/ Input enabled | Hi-Z/ Input enabled | | | Hi-Z/ Internal input fixed at "0" |
| K | Analog input selected | Hi-Z | Hi-Z/ Internal input fixed at "0"/ Analog input enabled | Hi-Z/ Internal input fixed at "0"/ Analog input enabled | Hi-Z/ Internal input fixed at "0"/ Analog input enabled | Hi-Z/ Internal input fixed at "0"/ Analog input enabled | Hi-Z/ Internal input fixed at "0"/ Analog input enabled |
| | GPIO selected, or other than above resource selected | Setting disabled | Setting disabled | Setting disabled | Maintain previous state | Maintain previous state | Hi-Z/ Internal input fixed at "0" |
| L | External interrupt enabled selected | Setting disabled | Setting disabled | Setting disabled | Maintain previous state | Maintain previous state | Maintain previous state |
| | Analog input selected | Hi-Z | Hi-Z/ Internal input fixed at "0"/ Analog input enabled | Hi-Z/ Internal input fixed at "0"/ Analog input enabled | Hi-Z/ Internal input fixed at "0"/ Analog input enabled | Hi-Z/ Internal input fixed at "0"/ Analog input enabled | Hi-Z/ Internal input fixed at "0"/ Analog input enabled |
| | GPIO selected, or other than above resource selected | Setting disabled | Setting disabled | Setting disabled | Maintain previous state | Maintain previous state | Hi-Z/ Internal input fixed at "0" |
| M | GPIO selected | Setting disabled | Setting disabled | Setting disabled | Maintain previous state | Maintain previous state | Hi-Z/ Internal input fixed at "0" |
| | Sub crystal oscillator input pin | Input enabled | Input enabled | Input enabled | Input enabled | Input enabled | Input enabled |

| Pin status type | Function group | Power-on reset or low voltage detection state | INITX input state | Device internal reset state | Run mode or sleep mode state | Timer mode or sleep mode state | |
|-----------------|-----------------------------------|---|--------------------------------------|--------------------------------------|------------------------------|---|---|
| | | Power supply unstable | Power supply stable | | Power supply stable | Power supply stable | |
| | | - | INITX=0 | INITX=1 | INITX=1 | INITX=1 | |
| | | - | - | - | - | SPL=0 | SPL=1 |
| N | GPIO selected | Setting disabled | Setting disabled | Setting disabled | Maintain previous state | Maintain previous state | Hi-Z/ Internal input fixed at "0" |
| | Sub crystal oscillator output pin | Hi-Z/ Internal input fixed at "0" | Hi-Z/ Internal input fixed at "0" | Hi-Z/ Internal input fixed at "0" | Maintain previous state | Maintain previous state/ Hi-Z at oscillation stop ^{*2} / Internal input fixed at "0" | Maintain previous state/ Hi-Z at oscillation stop ^{*2} / Internal input fixed at "0" |
| O | GPIO selected | Hi-Z | Hi-Z/ Input enabled | Hi-Z/ Input enabled | Maintain previous state | Maintain previous state | Hi-Z/ Internal input fixed at "0" |
| | USB I/O pin | Setting disabled | Setting disabled | Setting disabled | Maintain previous state | Hi-Z at transmission/ Input enabled/ Internal input fixed at "0" at reception | Hi-Z at transmission/ Input enabled/ Internal input fixed at "0" at reception |

*1: Oscillation is stopped at sub timer mode, Low speed CR timer mode, and stop mode.

*2: Oscillation is stopped at stop mode.

12. Electrical Characteristics

12.1 Absolute Maximum Ratings

| Parameter | Symbol | Rating | | Unit | Remarks |
|--|----------------------|-----------------------|--------------------------------------|------|--------------------|
| | | Min | Max | | |
| Power supply voltage ^{*1, *2} | V _{CC} | V _{SS} - 0.5 | V _{SS} + 6.5 | V | |
| Power supply voltage (for USB) ^{*1, *3} | USBV _{CC} | V _{SS} - 0.5 | V _{SS} + 6.5 | V | |
| Analog power supply voltage ^{*1, *4} | AV _{CC} | V _{SS} - 0.5 | V _{SS} + 6.5 | V | |
| Analog reference voltage ^{*1, *4} | AV _{RH} | V _{SS} - 0.5 | V _{SS} + 6.5 | V | |
| Input voltage ^{*1} | V _I | V _{SS} - 0.5 | V _{CC} + 0.5 (≤ 6.5V) | V | Except for USB pin |
| | | V _{SS} - 0.5 | USBV _{CC} + 0.5 (≤ 6.5V) | V | USB pin |
| Analog pin input voltage ^{*1} | V _{IA} | V _{SS} - 0.5 | AV _{CC} + 0.5 (≤ 6.5V) | V | |
| Output voltage ^{*1} | V _O | V _{SS} - 0.5 | V _{CC} + 0.5 (≤ 6.5V) | V | |
| Clamp maximum current | I _{CLAMP} | -2 | +2 | mA | *8 |
| Clamp total maximum current | ∑ I _{CLAMP} | | +20 | mA | *8 |
| "L" level maximum output current ^{*5} | I _{OL} | - | 10 | mA | 4 mA type |
| | | | 20 | mA | 12 mA type |
| | | | 39 | mA | P80, P81 |
| "L" level average output current ^{*6} | I _{OLAV} | - | 4 | mA | 4 mA type |
| | | | 12 | mA | 12 mA type |
| | | | 19.7 | mA | P80, P81 |
| "L" level total maximum output current | ∑ I _{OL} | - | 100 | mA | |
| "L" level total average output current ^{*7} | ∑ I _{OLAV} | - | 50 | mA | |
| "H" level maximum output current ^{*5} | I _{OH} | - | - 10 | mA | 4 mA type |
| | | | - 20 | mA | 12 mA type |
| | | | - 39 | mA | P80, P81 |
| "H" level average output current ^{*6} | I _{OHAV} | - | - 4 | mA | 4 mA type |
| | | | - 12 | mA | 12 mA type |
| | | | - 25.3 | mA | P80, P81 |
| "H" level total maximum output current | ∑ I _{OH} | - | - 100 | mA | |
| "H" level total average output current ^{*7} | ∑ I _{OHAV} | - | - 50 | mA | |
| Power consumption | P _D | - | 800 | mW | |
| Storage temperature | T _{STG} | - 55 | + 150 | °C | |

*1: These parameters are based on the condition that V_{SS} = AV_{SS} = 0.0 V.

*2: V_{CC} must not drop below V_{SS} - 0.5 V.

*3: USBV_{CC} must not drop below V_{SS} - 0.5 V.

*4: Be careful not to exceed V_{CC} + 0.5 V, for example, when the power is turned on.

*5: The maximum output current is the peak value for a single pin.

*6: The average output is the average current for a single pin over a period of 100 ms.

*7: The total average output current is the average current for all pins over a period of 100 ms.

- *8:
- See “4. List of Pin Functions” and “5. I/O Circuit Type” about +B input available pin.
 - Use within recommended operating conditions.
 - Use at DC voltage (current) the +B input.
 - The +B signal should always be applied a limiting resistance placed between the +B signal and the device.
 - The value of the limiting resistance should be set so that when the +B signal is applied the input current to the device pin does not exceed rated values, either instantaneously or for prolonged periods.
 - Note that when the device drive current is low, such as in the low-power consumption modes, the +B input potential may pass through the protective diode and increase the potential at the VCC and AVCC pin, and this may affect other devices.
 - Note that if a +B signal is input when the device power supply is off (not fixed at 0 V), the power supply is provided from the pins, so that incomplete operation may result.
 - The following is a recommended circuit example (I/O equivalent circuit).

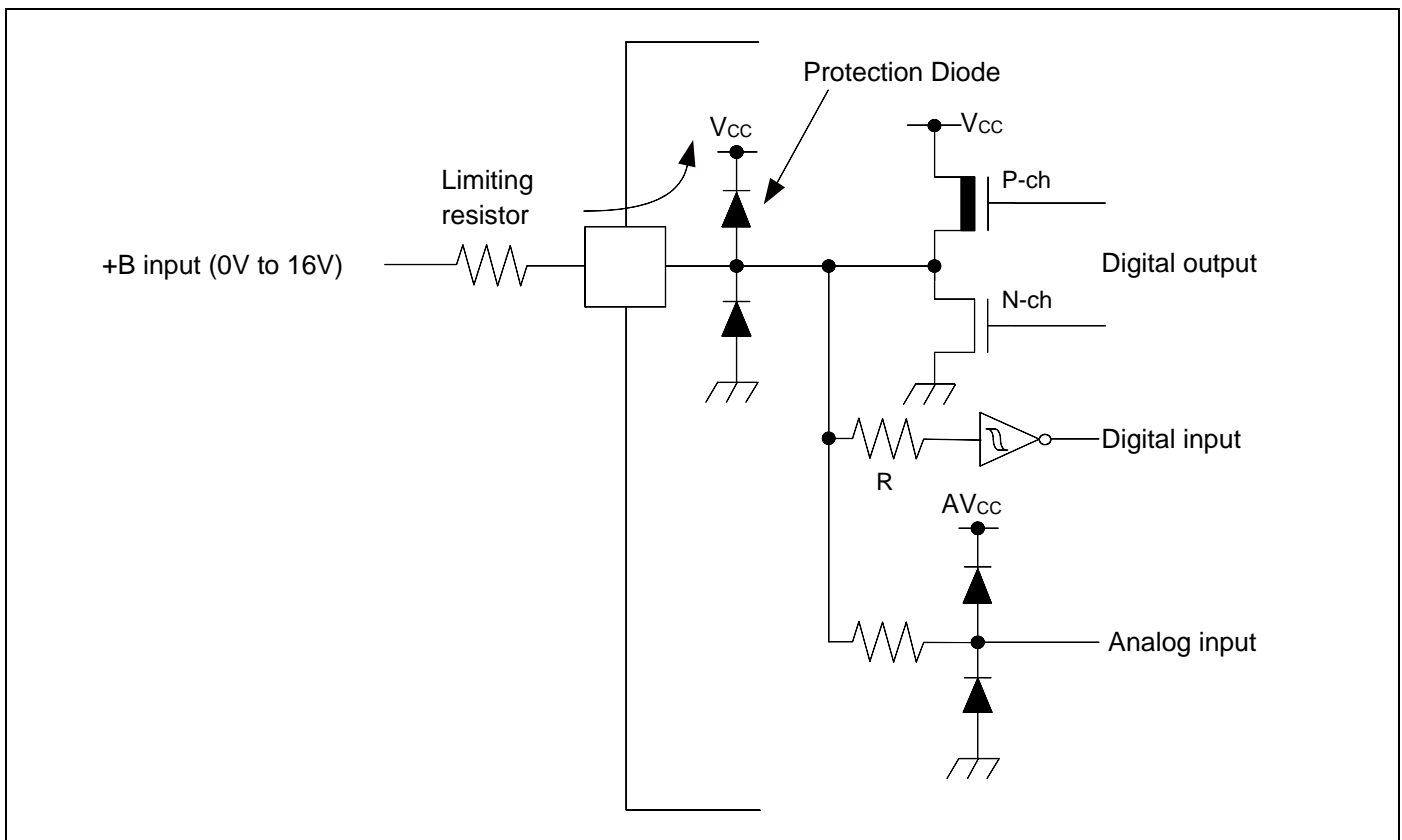

WARNING:

- Semiconductor devices can be permanently damaged by application of stress (voltage, current, temperature, etc.) in excess of absolute maximum ratings. Do not exceed these ratings.

12.2 Recommended Operating Conditions

 (V_{ss} = AV_{ss} = 0.0 V)

| Parameter | | Symbol | Conditions | Value | | Unit | Remarks |
|------------------------------|----------------------------|--------------------|---|--------------------|--------------------------|------|---------------------------------------|
| | | | | Min | Max | | |
| Power supply voltage | | V _{cc} | - | 2.7 * ⁴ | 5.5 | V | |
| Power supply voltage for USB | | USBV _{cc} | - | 3.0 | 3.6 (≤ V _{cc}) | V | *1 |
| | | | | 2.7 | 5.5 (≤ V _{cc}) | | *2 |
| Analog power supply voltage | | AV _{cc} | - | 2.7 | 5.5 | V | AV _{cc} = V _{cc} |
| Analog reference voltage | | AVRH | - | 2.7 | AV _{cc} | V | |
| Smoothing capacitor | | C _s | - | 1 | 10 | μF | For built-in regulator * ³ |
| Operating Temperature | LQM120 LQI100 LBC112 | T _A | When mounted on four-layer PCB | - 40 | + 85 | °C | |
| | | | When mounted on double-sided single-layer PCB | - 40 | + 85 | °C | I _{cc} ≤ 100 mA |
| | | | | - 40 | + 70 | °C | I _{cc} > 100 mA |

*1: When P81/UDP0 and P80/UDM0 pin are used as USB (UDP0, UDM0).

*2: When P81/UDP0 and P80/UDM0 pin are used as GPIO (P81, P80).

*3: See "C Pin" in "7. Handling Devices" for the connection of the smoothing capacitor.

*4: In between less than the minimum power supply voltage and low voltage reset/interrupt detection voltage or more, instruction execution and low voltage detection function by built-in High-speed CR (including Main PLL is used) or built-in Low-speed CR is possible to operate only.

WARNING:

- *The recommended operating conditions are required in order to ensure the normal operation of the semiconductor device. All of the device's electrical characteristics are warranted when the device is operated within these ranges. Always use semiconductor devices within their recommended operating condition ranges. Operation outside these ranges may adversely affect reliability and could result in device failure. No warranty is made with respect to uses, operating conditions, or combinations not represented on the datasheet. Users considering application outside the listed conditions are advised to contact their representatives beforehand.*

12.3 DC Characteristics

12.3.1 Current Rating

(V_{cc} = AV_{cc} = USBV_{cc} = 2.7 V to 5.5 V, V_{ss} = AV_{ss} = 0 V, T_A = - 40°C to + 85°C)

| Parameter | Symbol | Pin name | Conditions | Value | | Unit | Remarks | |
|--------------------|------------------|----------|--|---|-------------------|------|---------|--------|
| | | | | Typ ^{*3} | Max ^{*4} | | | |
| RUN mode current | I _{cc} | VCC | CPU: 80 MHz, Peripheral: 40 MHz, FLASH 2 Wait FRWTR.RWT = 10 FSYNDN.SD = 000 | 96 | 118 | mA | *1, *5 | |
| | | | CPU: 60 MHz, Peripheral: 30 MHz, FLASH 0 Wait FRWTR.RWT = 00 FSYNDN.SD = 000 | 76 | 94 | mA | *1, *3 | |
| | | | CPU: 80 MHz, Peripheral: 40 MHz, FLASH 5 Wait FRWTR.RWT = 10 FSYNDN.SD = 011 | 66 | 82 | mA | *1, *5 | |
| | | | CPU: 60 MHz, Peripheral: 30 MHz, FLASH 3Wait FRWTR.RWT = 00 FSYNDN.SD = 011 | 52 | 65 | mA | *3, *5 | |
| | | | High-speed CR RUN mode | CPU/Peripheral: 4 MHz ^{*2} FLASH 0Wait FRWTR.RWT = 00 FSYNDN.SD = 000 | 6.0 | 9.2 | mA | *1 |
| | | | Sub RUN mode | CPU/Peripheral: 32 kHz FLASH 0Wait FRWTR.RWT = 00 FSYNDN.SD = 000 | 0.2 | 2.24 | mA | *1, *6 |
| | | | Low-speed CR RUN mode | CPU/Peripheral: 100 kHz FLASH 0Wait FRWTR.RWT = 00 FSYNDN.SD = 000 | 0.3 | 2.36 | mA | *1 |
| SLEEP mode current | I _{ccs} | VCC | PLL SLEEP mode | Peripheral: 40 MHz | 43 | 54 | mA | *1, *5 |
| | | | High-speed CR SLEEP mode | Peripheral: 4 MHz ^{*2} | 3.5 | 6.2 | mA | *1 |
| | | | Sub SLEEP mode | Peripheral: 32 kHz | 0.15 | 2.18 | mA | *1, *6 |
| | | | Low-speed CR SLEEP mode | Peripheral: 100 kHz | 0.22 | 2.27 | mA | *1 |

*1: When all ports are fixed.

*2: When setting it to 4 MHz by trimming.

*3: T_A=+25°C, V_{cc}=3.3 V

*4: T_A=+85°C, V_{cc}=5.5 V

*5: When using the crystal oscillator of 4 MHz (Including the current consumption of the oscillation circuit)

*6: When using the crystal oscillator of 32 kHz (Including the current consumption of the oscillation circuit)

(V_{CC} = AV_{CC} = USBV_{CC} = 2.7 V to 5.5 V, V_{SS} = AV_{SS} = 0 V, T_A = - 40°C to + 85°C)

| Parameter | Symbol | Pin name | Conditions | Value | | Unit | Remarks | |
|--------------------|-------------------|-----------|------------------------------|------------------------------|-------------------|------|---------|--------|
| | | | | Typ ^{*2} | Max ^{*3} | | | |
| TIMER mode current | I _{CCCT} | VCC | Main TIMER mode | Ta = + 25°C, When LVD is off | 2.4 | 2.5 | mA | *1, *4 |
| | | | | Ta = + 85°C, When LVD is off | - | 5.4 | mA | *1, *4 |
| | | | Sub TIMER mode | Ta = + 25°C, When LVD is off | 110 | 300 | μA | *1, *5 |
| | | | | Ta = + 85°C, When LVD is off | - | 2.2 | mA | *1, *5 |
| STOP mode current | I _{CCCH} | STOP mode | Ta = + 25°C, When LVD is off | 50 | 200 | μA | *1 | |
| | | | Ta = + 85°C, When LVD is off | - | 2 | mA | *1 | |

*1: When all ports are fixed.

*2: V_{CC}=3.3 V

*3: V_{CC}=5.5 V

*4: When using the crystal oscillator of 4 MHz (Including the current consumption of the oscillation circuit)

*5: When using the crystal oscillator of 32 kHz (Including the current consumption of the oscillation circuit)

Low-Voltage Detection Current

(V_{CC} = 2.7 V to 5.5 V, V_{SS} = 0 V, T_A = - 40°C to + 85°C)

| Parameter | Symbol | Pin name | Conditions | Value | | Unit | Remarks |
|--|--------------------|----------|----------------------------|-------|-----|------|---------------|
| | | | | Typ | Max | | |
| Low-Voltage detection circuit (LVD) power supply current | I _{CCLVD} | VCC | At operation for interrupt | 2 | 10 | μA | At not detect |

Flash Memory Current

(V_{CC} = 2.7 V to 5.5 V, V_{SS} = 0 V, T_A = - 40°C to + 85°C)

| Parameter | Symbol | Pin name | Conditions | Value | | Unit | Remarks |
|----------------------------------|----------------------|----------|----------------|-------|-----|------|---------|
| | | | | Typ | Max | | |
| Flash memory write/erase current | I _{CCFLASH} | VCC | At Write/Erase | 13 | 24 | mA | |

A/D Converter Current

(V_{CC} = AV_{CC} = 2.7 V to 5.5 V, V_{SS} = AV_{SS} = AV_{RL} = 0 V, T_A = - 40°C to + 85°C)

| Parameter | Symbol | Pin name | Conditions | Value | | Unit | Remarks |
|--------------------------------|---------------------|----------|------------------------------|-------|-----|------|---------|
| | | | | Typ | Max | | |
| Power supply current | I _{CCAD} | AVCC | At 1unit operation | 2.3 | 3.6 | mA | |
| | | | At stop | 0.1 | 2 | μA | |
| Reference power supply current | I _{CCAVRH} | AVRH | At 1unit operation AVRH=5.5V | 2.2 | 3.0 | mA | |
| | | | At stop | 0.03 | 0.6 | μA | |

12.3.2 Pin Characteristics

 (V_{CC} = AV_{CC} = 2.7 V to 5.5 V, V_{SS} = AV_{SS} = 0 V, T_A = - 40°C to + 85°C)

| Parameter | Symbol | Pin name | Conditions | Value | | | Unit | Remarks |
|--|------------------|---|--|-----------------------|-----|-----------------------|------|---------|
| | | | | Min | Typ | Max | | |
| "H" level input voltage (hysteresis input) | V _{IHS} | CMOS hysteresis input pin, MD0,1 | - | V _{CC} × 0.8 | - | V _{CC} + 0.3 | V | |
| "L" level input voltage (hysteresis input) | V _{ILS} | CMOS hysteresis input pin, MD0,1 | - | V _{SS} - 0.3 | - | V _{CC} × 0.2 | V | |
| "H" level output voltage | V _{OH} | 4mA type | V _{CC} ≥ 4.5 V I _{OH} = - 4 mA | V _{CC} - 0.5 | - | V _{CC} | V | |
| | | | V _{CC} < 4.5 V I _{OH} = - 2 mA | | | | | |
| | | 12 mA type | V _{CC} ≥ 4.5 V I _{OH} = - 12 mA | V _{CC} - 0.5 | - | V _{CC} | V | |
| | | | V _{CC} < 4.5 V I _{OH} = - 8 mA | | | | | |
| | | P80, P81 | V _{CC} ≥ 4.5 V I _{OH} = - 25.3 mA | V _{CC} - 0.4 | - | V _{CC} | V | |
| | | | V _{CC} < 4.5 V I _{OH} = - 13.4 mA | | | | | |
| "L" level output voltage | V _{OL} | 4mA type | V _{CC} ≥ 4.5 V I _{OL} = 4 mA | V _{SS} | - | 0.4 | V | |
| | | | V _{CC} < 4.5 V I _{OL} = 2 mA | | | | | |
| | | 12mA type | V _{CC} ≥ 4.5 V I _{OL} = 12 mA | V _{SS} | - | 0.4 | V | |
| | | | V _{CC} < 4.5 V I _{OL} = 8 mA | | | | | |
| | | P80, P81 | V _{CC} ≥ 4.5 V I _{OL} = 19.7 mA | V _{SS} | - | 0.4 | V | |
| | | | V _{CC} < 4.5 V I _{OL} = 11.9 mA | | | | | |
| Input leak current | I _{IL} | - | - | - 5 | - | 5 | μA | |
| Pull-up resistance value | R _{PU} | Pull-up pin | V _{CC} ≥ 4.5 V | 25 | 50 | 100 | kΩ | |
| | | | V _{CC} < 4.5 V | 30 | 80 | 200 | | |
| Input capacitance | C _{IN} | Other than V _{CC} , V _{SS} , AV _{CC} , AV _{SS} , AVRH | - | - | 5 | 15 | pF | |

12.4 AC Characteristics

12.4.1 Main Clock Input Characteristics

(V_{CC} = 2.7 V to 5.5 V, V_{SS} = 0 V, T_A = - 40°C to + 85°C)

| Parameter | Symbol | Pin name | Conditions | Value | | Unit | Remarks | |
|---|-------------------------------|----------|-------------------------|--|-----|------|--------------------------------------|---------------------------|
| | | | | Min | Max | | | |
| Input frequency | F _{CH} | X0 X1 | V _{CC} ≥ 4.5 V | 4 | 48 | MHz | When crystal oscillator is connected | |
| | | | V _{CC} < 4.5 V | 4 | 20 | | | |
| | | | V _{CC} ≥ 4.5 V | 4 | 48 | MHz | When using external clock | |
| | | | V _{CC} < 4.5 V | 4 | 20 | | | |
| Input clock cycle | t _{CY_{LH}} | | V _{CC} ≥ 4.5 V | 20.83 | 250 | ns | When using external clock | |
| | | | V _{CC} < 4.5 V | 50 | 250 | | | |
| Input clock pulse width | - | | | PWH/t _{CY_{LH}} PWL/t _{CY_{LH}} | 45 | 55 | % | When using external clock |
| Input clock rise time and fall time | t _{CF} | | | - | - | 5 | ns | When using external clock |
| | t _{CR} | | - | - | | | | |
| Internal operating clock ^{*1} frequency | F _{CM} | - | - | - | 80 | MHz | Master clock | |
| | F _{CC} | - | - | - | 80 | MHz | Base clock (HCLK/FCLK) | |
| | F _{CP0} | - | - | - | 40 | MHz | APB0 bus clock ^{*2} | |
| | F _{CP1} | - | - | - | 40 | MHz | APB1 bus clock ^{*2} | |
| | F _{CP2} | - | - | - | 40 | MHz | APB2 bus clock ^{*2} | |
| Internal operating clock ^{*1} cycle time | t _{CY_{CC}} | - | - | 12.5 | - | ns | Base clock (HCLK/FCLK) | |
| | t _{CY_{CP0}} | - | - | 25 | - | ns | APB0 bus clock ^{*2} | |
| | t _{CY_{CP1}} | - | - | 25 | - | ns | APB1 bus clock ^{*2} | |
| | t _{CY_{CP2}} | - | - | 25 | - | ns | APB2 bus clock ^{*2} | |

*1: For more information about each internal operating clock, see "Chapter 2-1: Clock" in "FM3 Family Peripheral Manual".

*2: For about each APB bus which each peripheral is connected to, see "8. Block Diagram" in this datasheet.

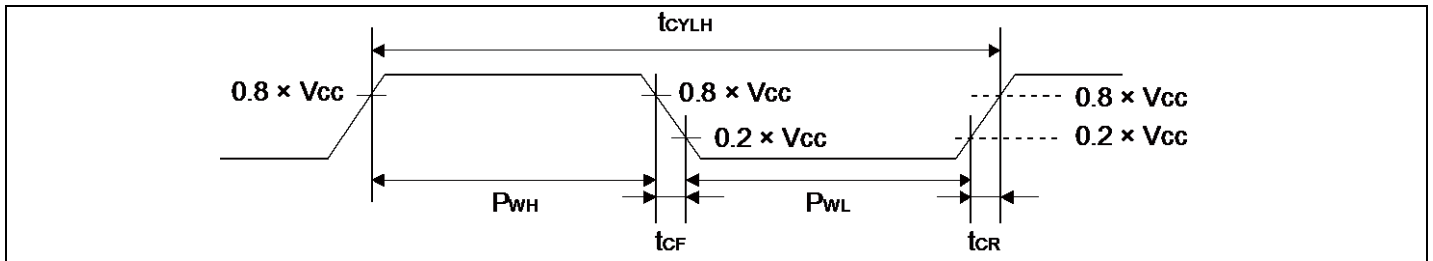

12.4.2 Sub Clock Input Characteristics

($V_{CC} = 2.7\text{ V to }5.5\text{ V}$, $V_{SS} = 0\text{ V}$, $T_A = -40^\circ\text{C to }+85^\circ\text{C}$)

| Parameter | Symbol | Pin name | Conditions | Value | | | Unit | Remarks |
|-------------------------|------------|------------|--|-------|--------|-------|---------------|--------------------------------------|
| | | | | Min | Typ | Max | | |
| Input frequency | F_{CL} | X0A X1A | - | - | 32.768 | - | kHz | When crystal oscillator is connected |
| Input clock cycle | t_{CYLL} | | - | 32 | - | 100 | | kHz |
| Input clock pulse width | - | | P_{WH}/t_{CYLL} P_{WL}/t_{CYLL} | 10 | - | 31.25 | μs | When using external clock |
| | | | | 45 | - | 55 | % | When using external clock |

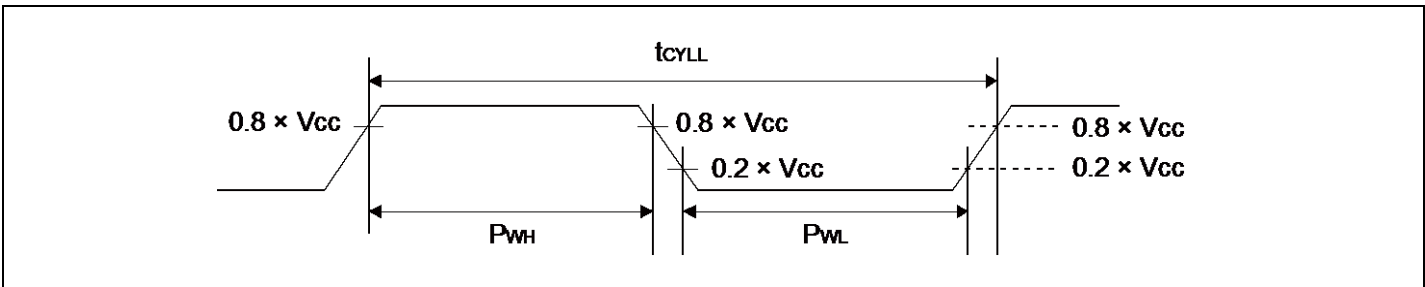

12.4.3 Built-in CR Oscillation Characteristics
Built-in high-speed CR

 (V_{CC} = 2.7 V to 5.5 V, V_{SS} = 0 V, T_A = - 40°C to + 85°C)

| Parameter | Symbol | Conditions | Value | | | Unit | Remarks |
|--------------------------|-------------------|-----------------------------------|-------|-----|------|------|-------------------|
| | | | Min | Typ | Max | | |
| Clock frequency | F _{CRH} | T _A = + 25°C | 3.92 | 4 | 4.08 | MHz | When trimming *1 |
| | | T _A = 0°C to + 70°C | 3.84 | 4 | 4.16 | | |
| | | T _A = - 40°C to + 85°C | 3.8 | 4 | 4.2 | | |
| | | T _A = - 40°C to + 85°C | 3 | 4 | 6 | | When not trimming |
| Frequency stability time | t _{CRWT} | - | - | - | 50 | μs | *2 |

*1: In the case of using the values in CR trimming area of Flash memory at shipment for frequency trimming.

*2: Frequency stable time is time to stable of the frequency of the High-speed CR clock after the trim value is set. After setting the trim value, the period when the frequency stability time passes can use the High-speed CR clock as a source clock.

Built-in low-speed CR

 (V_{CC} = 2.7 V to 5.5 V, V_{SS} = 0 V, T_A = - 40°C to + 85°C)

| Parameter | Symbol | Conditions | Value | | | Unit | Remarks |
|-----------------|------------------|------------|-------|-----|-----|------|---------|
| | | | Min | Typ | Max | | |
| Clock frequency | F _{CRL} | - | 50 | 100 | 150 | kHz | |

12.4.4 Operating Conditions of Main and USB PLL (In the case of using main clock for input of PLL)

 (V_{CC} = 2.7 V to 5.5 V, V_{SS} = 0 V, T_A = - 40°C to + 85°C)

| Parameter | Symbol | Value | | | Unit | Remarks |
|--|----------------------|-------|-----|-----|----------|--------------------------------|
| | | Min | Typ | Max | | |
| PLL oscillation stabilization wait time (LOCK UP time) *1 | t _{LOCK} | 100 | - | - | μs | |
| PLL input clock frequency | f _{PLLI} | 4 | - | 30 | MHz | |
| PLL multiple rate | - | 4 | - | 30 | multiple | |
| PLL macro oscillation clock frequency | f _{PLLO} | 60 | - | 120 | MHz | |
| Main PLL clock frequency *2 | F _{CLKPLL} | - | - | 80 | MHz | |
| USB clock frequency *3 | F _{CLKSPLL} | - | - | 48 | MHz | After the M frequency division |

*1: Time from when the PLL starts operating until the oscillation stabilizes.

*2: For more information about Main PLL clock (CLKPLL), see "Chapter 2-1: Clock" in "FM3 Family Peripheral Manual".

*3: For more information about USB clock, see "Chapter 2-2: USB Clock Generation" in "FM3 Family Peripheral Manual Communication Macro Part".

12.4.5 Operating Conditions of Main PLL (In the case of using built-in high speed CR)

 (V_{CC} = 2.7 V to 5.5 V, V_{SS} = 0 V, T_A = - 40°C to + 85°C)

| Parameter | Symbol | Value | | | Unit | Remarks |
|--|---------------------|-------|-----|-----|----------|---------|
| | | Min | Typ | Max | | |
| PLL oscillation stabilization wait time (LOCK UP time) *1 | t _{LOCK} | 100 | - | - | μs | |
| PLL input clock frequency | f _{PLLI} | 3.8 | 4 | 4.2 | MHz | |
| PLL multiple rate | - | 15 | - | 28 | multiple | |
| PLL macro oscillation clock frequency | f _{PLLO} | 57 | - | 120 | MHz | |
| Main PLL clock frequency *2 | F _{CLKPLL} | - | - | 80 | MHz | |

*1: Time from when the PLL starts operating until the oscillation stabilizes.

*2: For more information about Main PLL clock (CLKPLL), see "Chapter 2-1: Clock" in "FM3 Family Peripheral Manual".

Note:

- Make sure to input to the main PLL source clock, the high-speed CR clock (CLKHC) that the frequency has been trimmed.

Main PLL connection

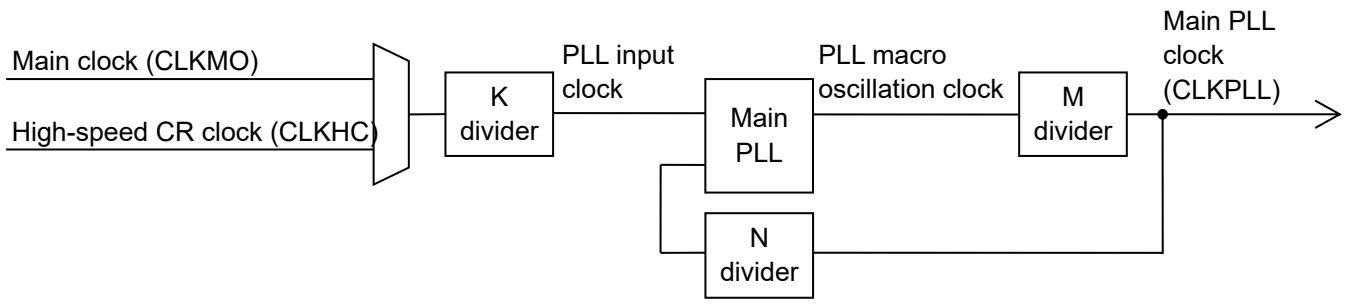

USB PLL connection

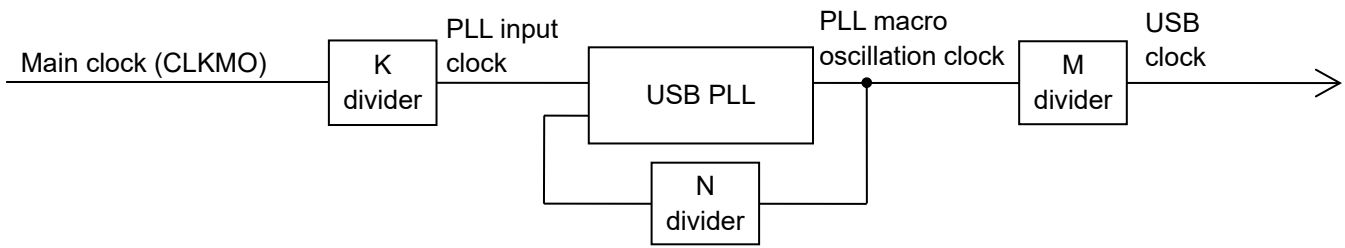

12.4.6 Reset Input Characteristics

 (V_{CC} = 2.7 V to 5.5 V, V_{SS} = 0 V, T_A = - 40°C to + 85°C)

| Parameter | Symbol | Pin name | Conditions | Value | | Unit | Remarks |
|------------------|--------------------|----------|------------|-------|-----|------|---------|
| | | | | Min | Max | | |
| Reset input time | t _{INITX} | INITX | - | 500 | - | ns | |

12.4.7 Power-on Reset Timing

 (V_{CC} = 2.7 V to 5.5 V, V_{SS} = 0 V, T_A = - 40°C to + 85°C)

| Parameter | Symbol | Pin name | Value | | Unit | Remarks |
|-------------------------------------|--------|----------|-------|-------|------|---------|
| | | | Min | Max | | |
| Power supply rising time | Tr | VCC | 0 | - | ms | |
| Power supply shut down time | Toff | | 1 | - | ms | |
| Time until releasing Power-on reset | Tprt | | 0.422 | 0.704 | ms | |

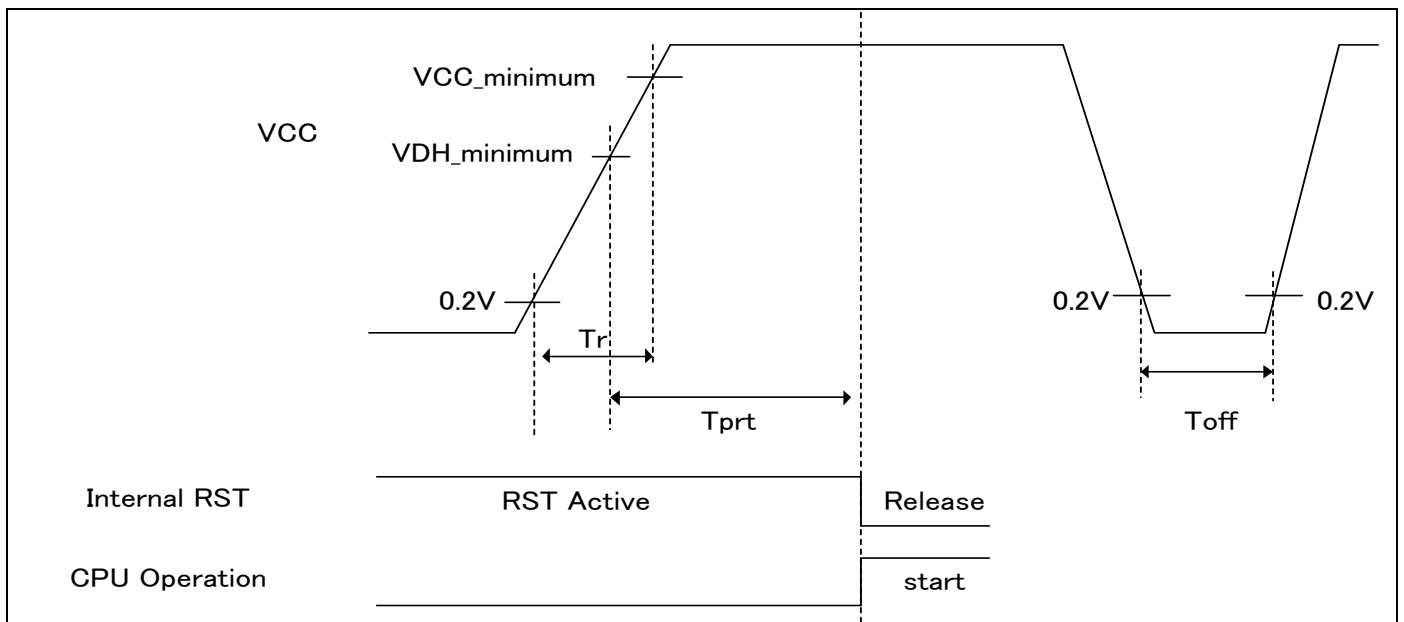
Glossary

 VCC_{minimum}: Minimum V_{CC} of recommended operating conditions

 VDH_{minimum}: Minimum release voltage of Low-Voltage detection reset.

See "12.7. Low-Voltage Detection Characteristics"

12.4.8 External Bus Timing
Asynchronous SRAM Mode
(V_{CC} = 2.7 V to 5.5 V, V_{SS} = 0 V, T_A = - 40°C to + 85°C)

| Parameter | Symbol | Pin name | Conditions | Value | | Unit | Remarks |
|--------------------------------|-------------------------|----------------------|--|---|----------|------|---------|
| | | | | Min | Max | | |
| MOEX Min pulse width | t _{OEW} | MOEX | V _{CC} ≥ 4.5 V V _{CC} < 4.5 V | T _{HCLK} × 1 - 3 | - | ns | |
| MOEX ↓ ⇒ Address delay time | t _{OEL - AV} | MOEX MAD24 to 00 | V _{CC} ≥ 4.5 V V _{CC} < 4.5 V | 0 0 | 10 20 | ns | |
| MOEX ↑ ⇒ Address delay time | t _{OEH - AX} | MOEX MAD24 to 00 | V _{CC} ≥ 4.5 V V _{CC} < 4.5 V | 0 0 | 10 20 | ns | |
| MOEX ↓ ⇒ MCSX ↓ delay time | t _{OEL - CSL} | MOEX MCSX | V _{CC} ≥ 4.5 V V _{CC} < 4.5 V | 0 | 10 | ns | |
| MOEX ↑ ⇒ MCSX ↑ delay time | t _{OEH - CSH} | MOEX MCSX | V _{CC} ≥ 4.5 V V _{CC} < 4.5 V | 0 | 10 | ns | |
| Data set up ⇒ MOEX ↑ time | t _{DS - OE} | MOEX MDATA15 to 0 | V _{CC} ≥ 4.5 V V _{CC} < 4.5 V | 20 38 | - | ns | |
| MOEX ↑ ⇒ Data hold time | t _{DH - OE} | MOEX MDATA15 to 0 | V _{CC} ≥ 4.5 V V _{CC} < 4.5 V | 0 | - | ns | |
| MCSX ↓ ⇒ MWEX ↓ delay time | t _{CSL - WEL} | MCSX MWEX | V _{CC} ≥ 4.5 V V _{CC} < 4.5 V | T _{HCLK} × 1 - 5 T _{HCLK} × 1 - 10 | - | ns | |
| MWEX ↑ ⇒ MCSX ↑ delay time | t _{WEH - CSH} | MCSX MWEX | V _{CC} ≥ 4.5 V V _{CC} < 4.5 V | T _{HCLK} × 1 - 5 T _{HCLK} × 1 - 10 | - | ns | |
| Address ⇒ MWEX ↓ delay time | t _{AV - WEL} | MWEX MAD24 to 00 | V _{CC} ≥ 4.5 V V _{CC} < 4.5 V | T _{HCLK} × 1 - 5 T _{HCLK} × 1 - 15 | - | ns | |
| MWEX ↑ ⇒ Address delay time | t _{WEH - AX} | MWEX MAD24 to 00 | V _{CC} ≥ 4.5 V V _{CC} < 4.5 V | T _{HCLK} × 1 - 5 T _{HCLK} × 1 - 15 | - | ns | |
| MWEX ↓ ⇒ MDQM ↓ delay time | t _{WEL - DQML} | MWEX MDQM0 to 1 | V _{CC} ≥ 4.5 V V _{CC} < 4.5 V | 0 0 | 5 10 | ns | |
| MWEX ↑ ⇒ MDQM ↑ delay time | t _{WEH - DQMH} | MWEX MDQM0 to 1 | V _{CC} ≥ 4.5 V V _{CC} < 4.5 V | 0 0 | 5 10 | ns | |
| MWEX Min pulse width | t _{WEW} | MWEX | V _{CC} ≥ 4.5 V V _{CC} < 4.5 V | T _{HCLK} × 1 - 3 | - | ns | |
| MWEX ↓ ⇒ Data delay time | t _{WEL - DV} | MWEX MDATA15 to 0 | V _{CC} ≥ 4.5 V V _{CC} < 4.5 V | - 5 -15 | 5 15 | ns | |
| MWEX ↑ ⇒ Data delay time | t _{WEH - DX} | MWEX MDATA15 to 0 | V _{CC} ≥ 4.5 V V _{CC} < 4.5 V | T _{HCLK} × 1 - 5 T _{HCLK} × 1 - 15 | - | ns | |

Note:

- When the external load capacitance = 50 pF.

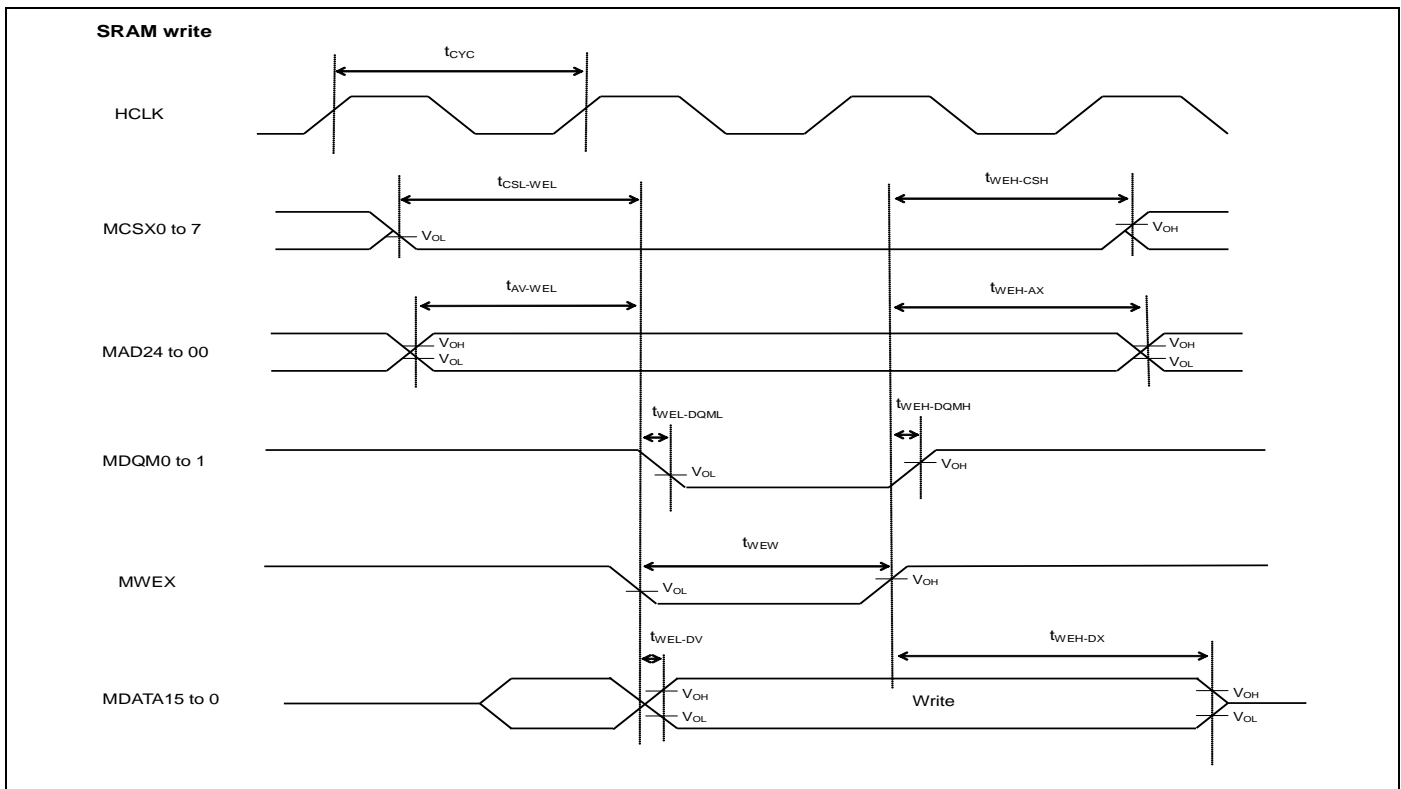
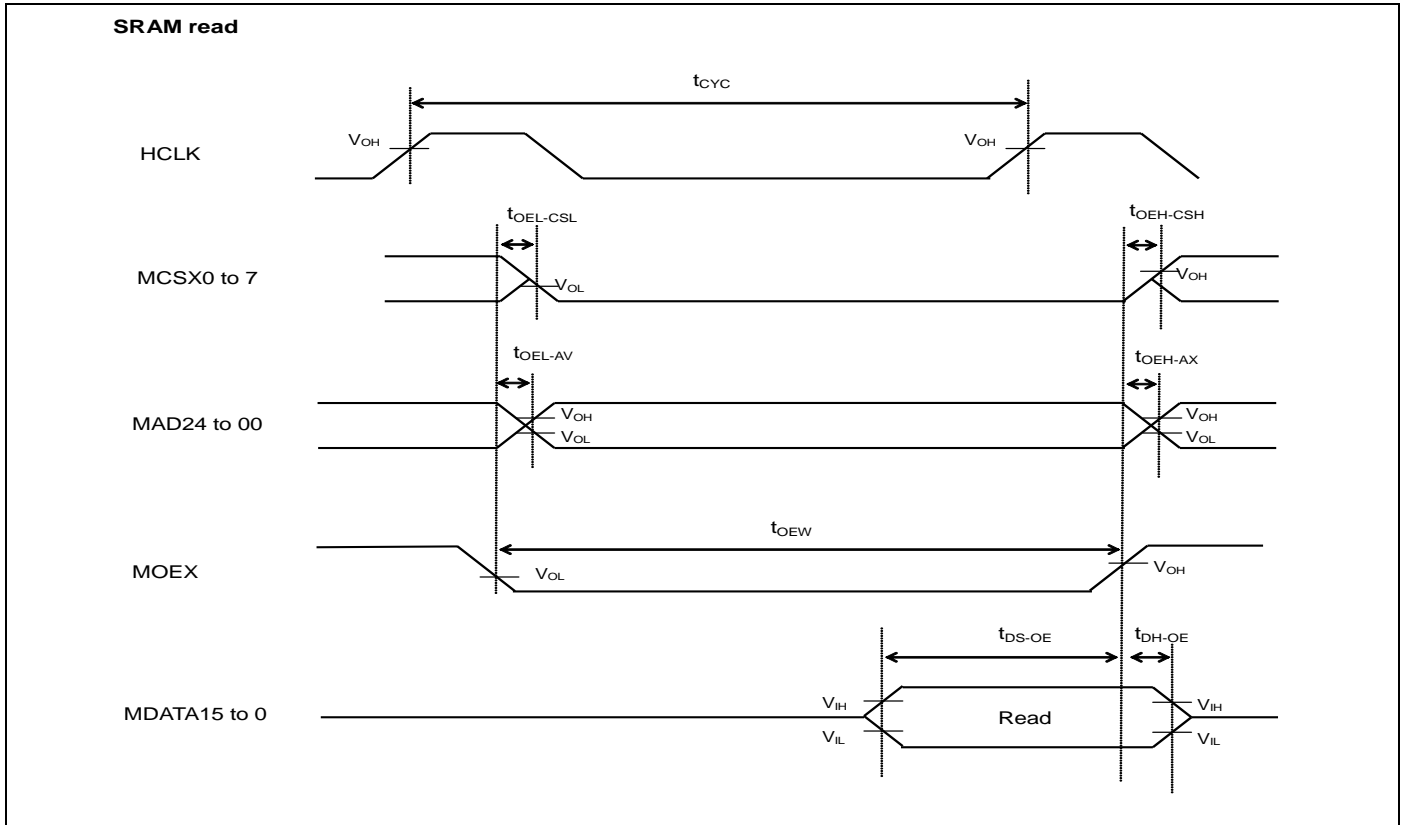

NAND FLASH mode

 (V_{CC} = 2.7 V to 5.5 V, V_{SS} = 0 V, T_A = - 40°C to + 85°C)

| Parameter | Symbol | Pin name | Conditions | Value | | Unit | Remarks |
|--------------------------------|--------------------------|-----------------------|--|---|------------|------|---------|
| | | | | Min | Max | | |
| MNREX Min pulse width | t _{NREW} | MNREX | V _{CC} ≥ 4.5 V V _{CC} < 4.5 V | T _{HCLK} × 1 - 3 | - | ns | |
| Data set up ⇒ MNREX ↑ tiime | t _{DS - NRE} | MNREX MDATA15 to 0 | V _{CC} ≥ 4.5 V V _{CC} < 4.5 V | 20 38 | - - | ns | |
| MNREX ↑ ⇒ Data hold time | t _{DH - NRE} | MNREX MDATA15 to 0 | V _{CC} ≥ 4.5 V V _{CC} < 4.5 V | 0 0 | - - | ns | |
| MNALE ↑ ⇒ MNWEX delay time | t _{ALEH - NWEL} | MNALE MNWEX | V _{CC} ≥ 4.5 V V _{CC} < 4.5 V | T _{HCLK} × 1 - 5 T _{HCLK} × 1 - 15 | - - | ns | |
| MNWEH ↑ ⇒ MNALE delay time | t _{NWEH - ALEL} | MNALE MNWEX | V _{CC} ≥ 4.5 V V _{CC} < 4.5 V | T _{HCLK} × 1 - 5 T _{HCLK} × 1 - 15 | - - | ns | |
| MNCLE ↑ ⇒ MNWEX delay time | t _{CLEH - NWEL} | MNCLE MNWEX | V _{CC} ≥ 4.5 V V _{CC} < 4.5 V | T _{HCLK} × 1 - 5 T _{HCLK} × 1 - 15 | - - | ns | |
| MNWEH ↑ ⇒ MNCLE delay time | t _{NWEH - CLEL} | MNCLE MNWEX | V _{CC} ≥ 4.5 V V _{CC} < 4.5 V | T _{HCLK} × 1 - 5 T _{HCLK} × 1 - 15 | - - | ns | |
| MNWEH Min pulse width | t _{NWEW} | MNWEH | V _{CC} ≥ 4.5 V V _{CC} < 4.5 V | T _{HCLK} × 1 - 3 | - | ns | |
| MNWEH ↓ ⇒ Data delay time | t _{NWEL - DV} | MNWEH MDATA15 to 0 | V _{CC} ≥ 4.5 V V _{CC} < 4.5 V | - 5 -15 | + 5 +15 | ns | |
| MNWEH ↑ ⇒ Data delay time | t _{NWEH - DX} | MNWEH MDATA15 to 0 | V _{CC} ≥ 4.5 V V _{CC} < 4.5 V | T _{HCLK} × 1 - 5 T _{HCLK} × 1 - 15 | - - | ns | |

Note:

- When the external load capacitance = 50 pF.

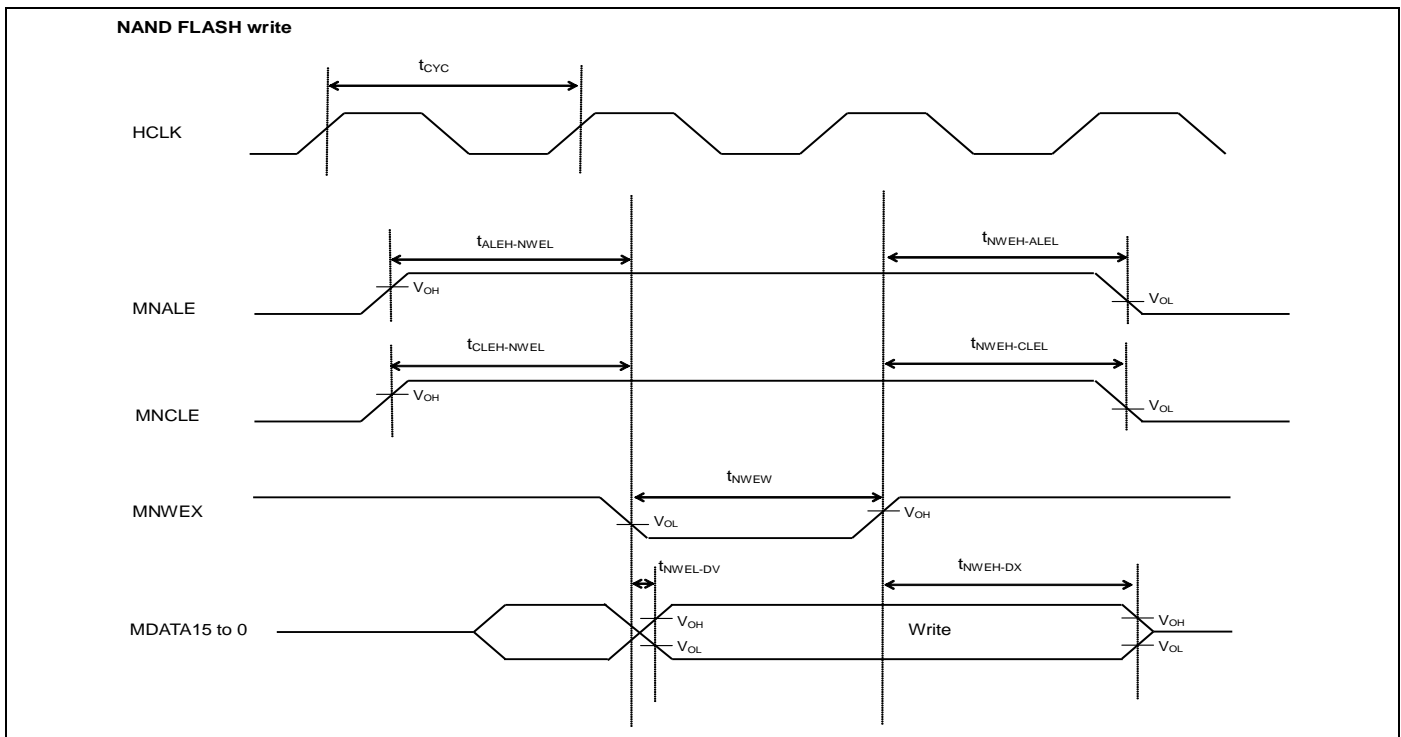
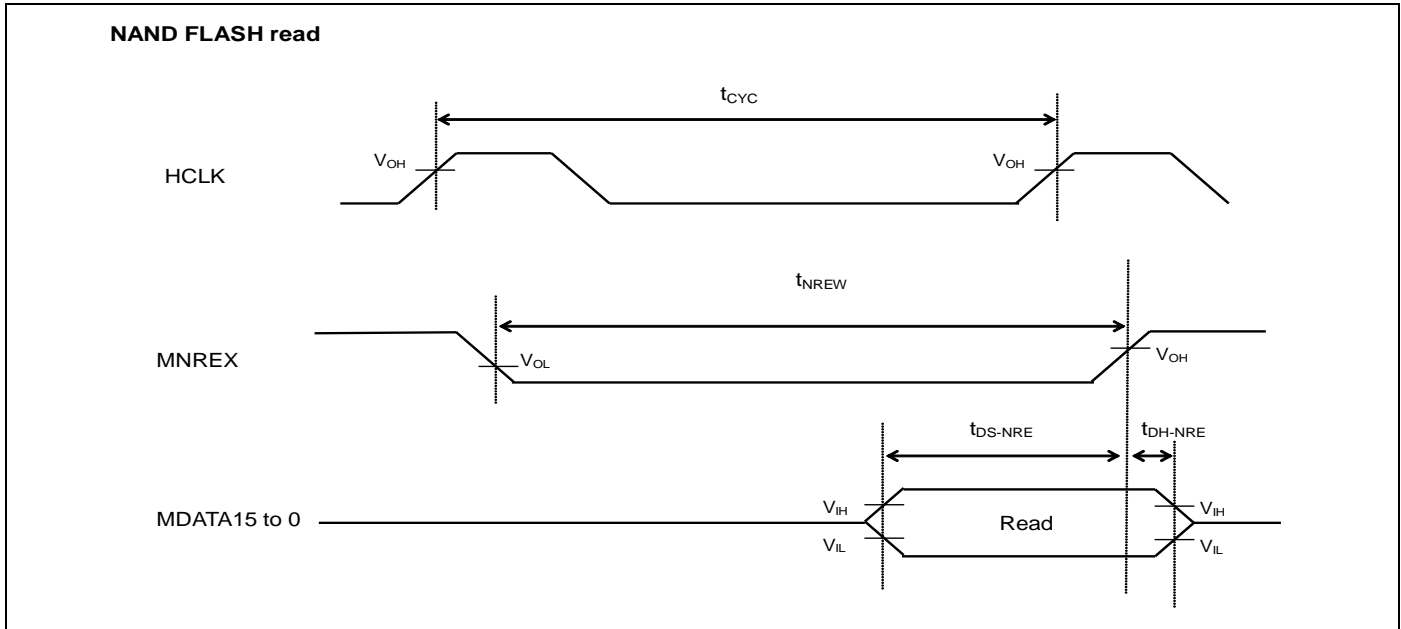

12.4.9 Base Timer Input Timing

Timer input timing

($V_{CC} = 2.7\text{ V to }5.5\text{ V}$, $V_{SS} = 0\text{ V}$, $T_A = -40^\circ\text{C to }+85^\circ\text{C}$)

| Parameter | Symbol | Pin name | Conditions | Value | | Unit | Remarks |
|-------------------|--------------------------|---|------------|-------------|-----|------|---------|
| | | | | Min | Max | | |
| Input pulse width | t_{TIWH} t_{TIWL} | TIOAn/TIOBn (when using as ECK,TIN) | - | $2t_{CYCP}$ | - | ns | |

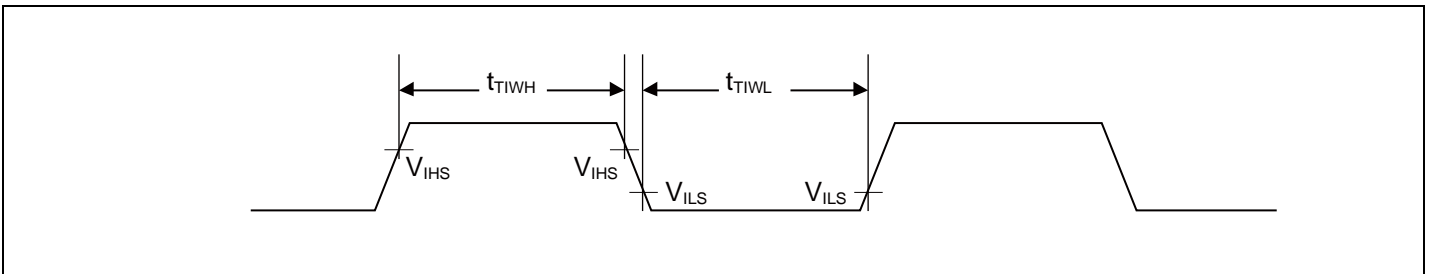

Trigger input timing

($V_{CC} = 2.7\text{ V to }5.5\text{ V}$, $V_{SS} = 0\text{ V}$, $T_A = -40^\circ\text{C to }+85^\circ\text{C}$)

| Parameter | Symbol | Pin name | Conditions | Value | | Unit | Remarks |
|-------------------|--------------------------|--|------------|-------------|-----|------|---------|
| | | | | Min | Max | | |
| Input pulse width | t_{TRGH} t_{TRGL} | TIOAn/TIOBn (when using as TGIN) | - | $2t_{CYCP}$ | - | ns | |

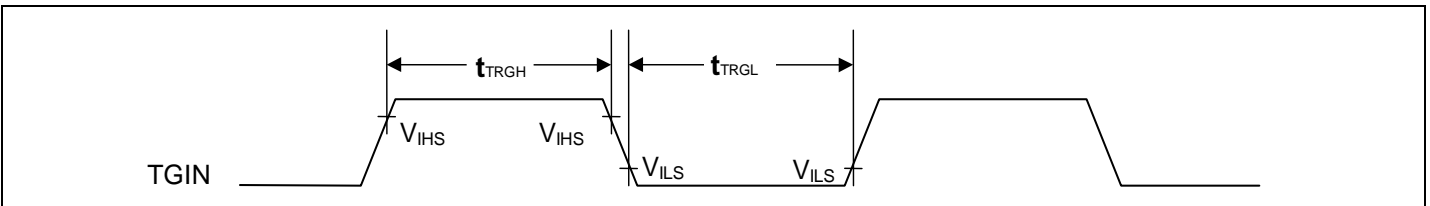

Note:

- t_{CYCP} indicates the APB bus clock cycle time.
About the APB bus number which the Base Timer is connected to, see "8. Block Diagram" in this datasheet.

12.4.10 CSIO/UART Timing
CSIO (SPI = 0, SCINV = 0)
(V_{CC} = 2.7 V to 5.5 V, V_{SS} = 0 V, T_A = - 40°C to + 85°C)

| Parameter | Symbol | Pin name | Conditions | V _{CC} < 4.5 V | | V _{CC} ≥ 4.5 V | | Unit |
|------------------------------|--------------------|--------------|-------------|-------------------------|-----|-------------------------|------|------|
| | | | | Min | Max | Min | Max | |
| Baud Rate | - | - | - | - | 8 | - | 8 | Mbps |
| Serial clock cycle time | t _{SCYC} | SCKx | Master mode | 4t _{CYCP} | - | 4t _{CYCP} | - | ns |
| SCK ↓ → SOT delay time | t _{SLOVI} | SCKx SOTx | | -30 | +30 | - 20 | + 20 | ns |
| SIN → SCK ↑ setup time | t _{IVSHI} | SCKx SINx | | 50 | - | 30 | - | ns |
| SCK ↑ → SIN hold time | t _{SHIXI} | SCKx SINx | | 0 | - | 0 | - | ns |
| Serial clock "L" pulse width | t _{SLSH} | SCKx | Slave mode | 2t _{CYCP} - 10 | - | 2t _{CYCP} - 10 | - | ns |
| Serial clock "H" pulse width | t _{SHSL} | SCKx | | t _{CYCP} + 10 | - | t _{CYCP} + 10 | - | ns |
| SCK ↓ → SOT delay time | t _{SLOVE} | SCKx SOTx | | - | 50 | - | 30 | ns |
| SIN → SCK ↑ setup time | t _{IVSHE} | SCKx SINx | | 10 | - | 10 | - | ns |
| SCK ↑ → SIN hold time | t _{SHIXE} | SCKx SINx | | 20 | - | 20 | - | ns |
| SCK fall time | t _F | SCKx | | - | 5 | - | 5 | ns |
| SCK rise time | t _R | SCKx | - | 5 | - | 5 | ns | |

Notes:

- The above characteristics apply to CLK synchronous mode.
- t_{CYCP} indicates the APB bus clock cycle time.
- About the APB bus number which Multi-function Serial is connected to, see "8. Block Diagram" in this datasheet.
- These characteristics only guarantee the same relocate port number.
For example, the combination of SCKx_0 and SOTx_1 is not guaranteed.
- When the external load capacitance = 50 pF.

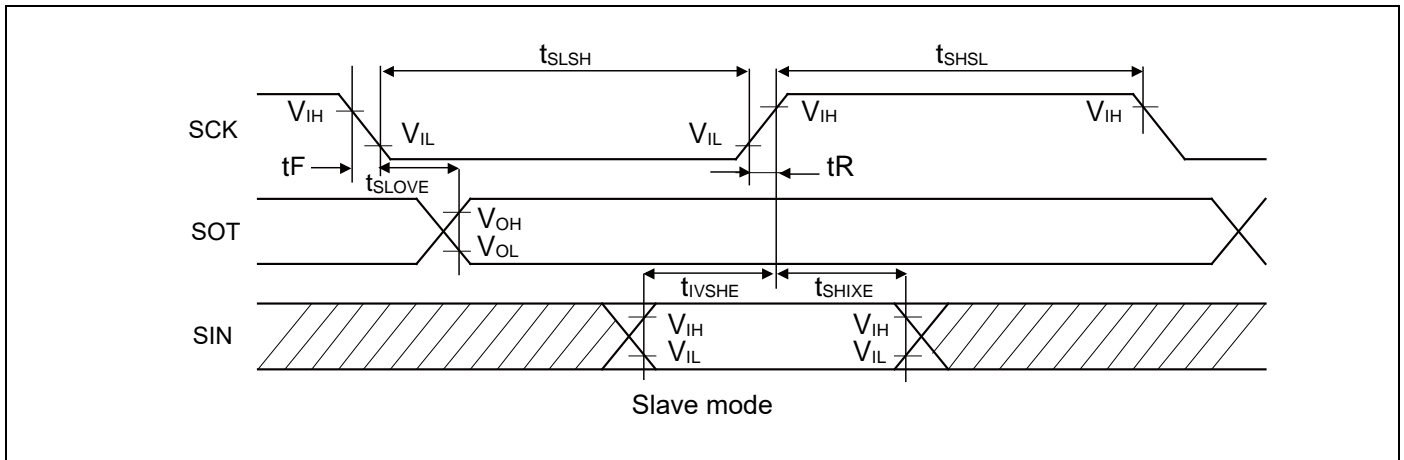
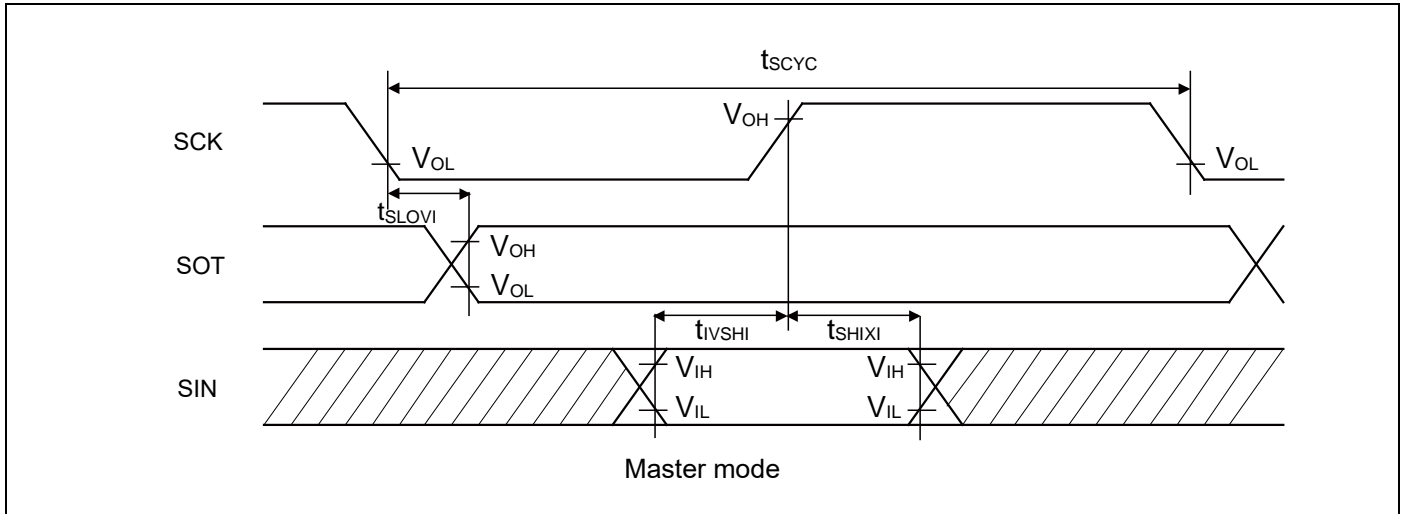

CSIO (SPI = 0, SCINV = 1)

 (V_{CC} = 2.7 V to 5.5 V, V_{SS} = 0 V, T_A = - 40°C to + 85°C)

| Parameter | Symbol | Pin name | Conditions | V _{CC} < 4.5 V | | V _{CC} ≥ 4.5 V | | Unit |
|------------------------------|--------------------|--------------|------------------------|-------------------------|------------------------|-------------------------|------|------|
| | | | | Min | Max | Min | Max | |
| Baud Rate | - | - | - | - | 8 | - | 8 | Mbps |
| Serial clock cycle time | t _{SCYC} | SCKx | Master mode | 4t _{CYCP} | - | 4t _{CYCP} | - | ns |
| SCK ↑ → SOT delay time | t _{SHOVI} | SCKx SOTx | | -30 | +30 | - 20 | + 20 | ns |
| SIN → SCK ↓ setup time | t _{IVSLI} | SCKx SINx | | 50 | - | 30 | - | ns |
| SCK ↓ → SIN hold time | t _{SLIXI} | SCKx SINx | | 0 | - | 0 | - | ns |
| Serial clock "L" pulse width | t _{SLSH} | SCKx | | 2t _{CYCP} - 10 | - | 2t _{CYCP} - 10 | - | ns |
| Serial clock "H" pulse width | t _{SHSL} | SCKx | t _{CYCP} + 10 | - | t _{CYCP} + 10 | - | ns | |
| SCK ↑ → SOT delay time | t _{SHOVE} | SCKx SOTx | Slave mode | - | 50 | - | 30 | ns |
| SIN → SCK ↓ setup time | t _{IVSLE} | SCKx SINx | | 10 | - | 10 | - | ns |
| SCK ↓ → SIN hold time | t _{SLIXE} | SCKx SINx | | 20 | - | 20 | - | ns |
| SCK fall time | t _F | SCKx | | - | 5 | - | 5 | ns |
| SCK rise time | t _R | SCKx | | - | 5 | - | 5 | ns |

Notes:

- The above characteristics apply to CLK synchronous mode.
- t_{CYCP} indicates the APB bus clock cycle time.
About the APB bus number which Multi-function serial is connected to, see "8. Block Diagram" in this datasheet.
- These characteristics only guarantee the same relocate port number.
For example, the combination of SCKx_0 and SOTx_1 is not guaranteed.
- When the external load capacitance = 50 pF.

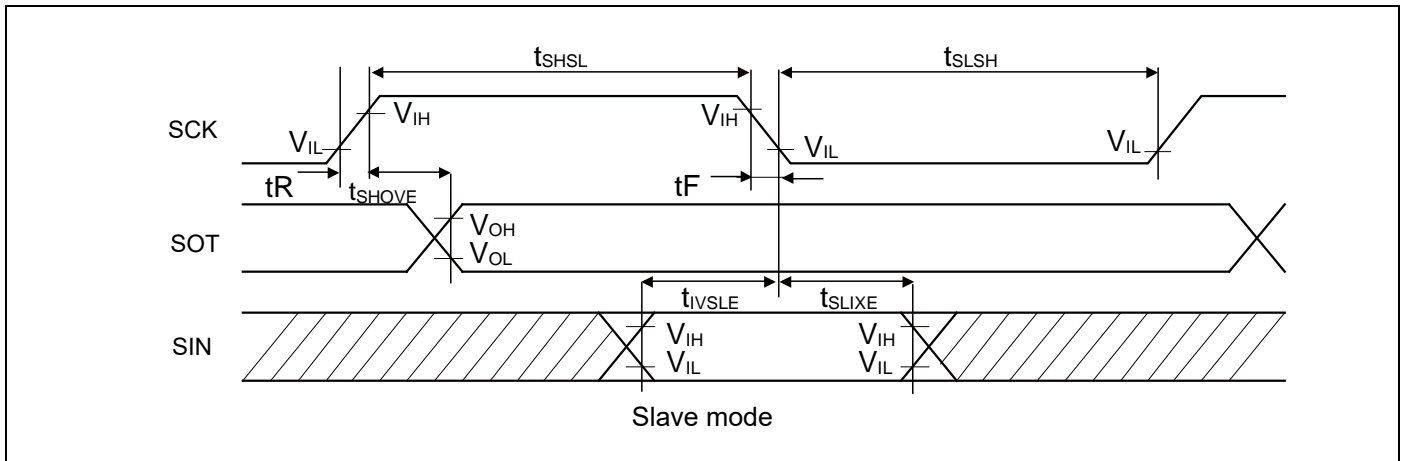
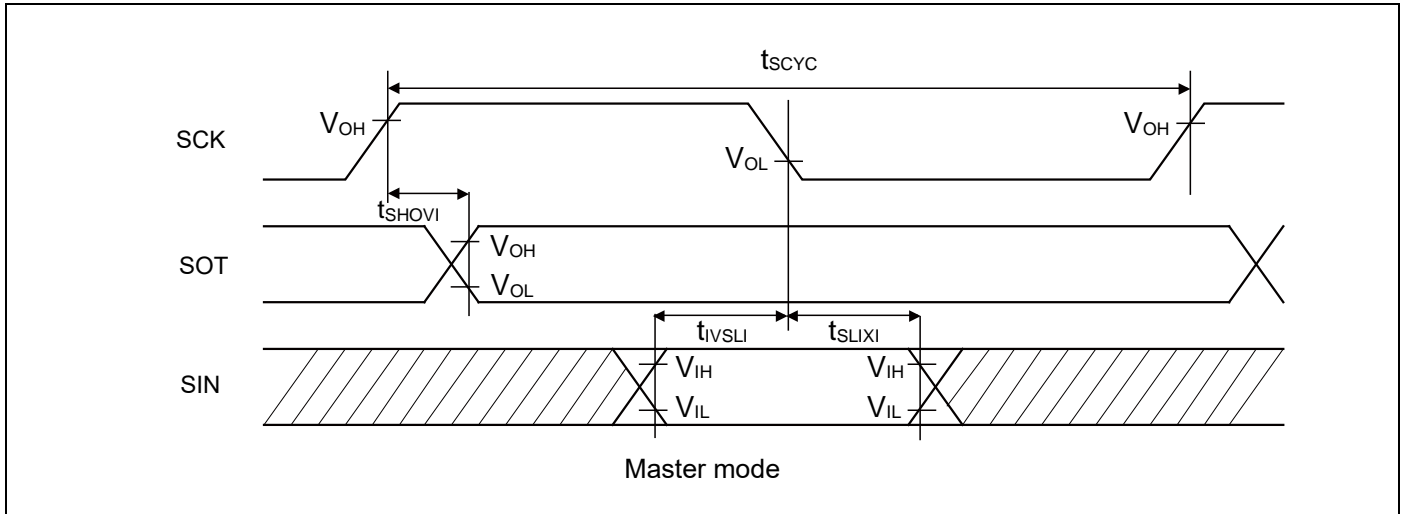

CSIO (SPI = 1, SCINV = 0)

(V_{CC} = 2.7 V to 5.5 V, V_{SS} = 0 V, T_A = - 40°C to + 85°C)

| Parameter | Symbol | Pin name | Conditions | V _{CC} < 4.5 V | | V _{CC} ≥ 4.5 V | | Unit |
|------------------------------|--------------------|--------------|------------------------|-------------------------|------------------------|-------------------------|------|------|
| | | | | Min | Max | Min | Max | |
| Baud Rate | - | - | - | - | 8 | - | 8 | Mbps |
| Serial clock cycle time | t _{SCYC} | SCKx | Master mode | 4t _{CYCP} | - | 4t _{CYCP} | - | ns |
| SCK ↑ → SOT delay time | t _{SHOVI} | SCKx SOTx | | -30 | +30 | - 20 | + 20 | ns |
| SIN → SCK ↓ setup time | t _{IVSLI} | SCKx SINx | | 50 | - | 30 | - | ns |
| SCK ↓ → SIN hold time | t _{SLIXI} | SCKx SINx | | 0 | - | 0 | - | ns |
| SOT → SCK ↓ delay time | t _{SOVLI} | SCKx SOTx | | 2t _{CYCP} - 30 | - | 2t _{CYCP} - 30 | - | ns |
| Serial clock "L" pulse width | t _{LSLH} | SCKx | | 2t _{CYCP} - 10 | - | 2t _{CYCP} - 10 | - | ns |
| Serial clock "H" pulse width | t _{SHSL} | SCKx | t _{CYCP} + 10 | - | t _{CYCP} + 10 | - | ns | |
| SCK ↑ → SOT delay time | t _{SHOVE} | SCKx SOTx | Slave mode | - | 50 | - | 30 | ns |
| SIN → SCK ↓ setup time | t _{IVSLE} | SCKx SINx | | 10 | - | 10 | - | ns |
| SCK ↓ → SIN hold time | t _{SLIXE} | SCKx SINx | | 20 | - | 20 | - | ns |
| SCK fall time | t _F | SCKx | | - | 5 | - | 5 | ns |
| SCK rise time | t _R | SCKx | | - | 5 | - | 5 | ns |

Notes:

- The above characteristics apply to CLK synchronous mode.
- t_{CYCP} indicates the APB bus clock cycle time.
About the APB bus number which Multi-function Serial is connected to, see "8. Block Diagram" in this datasheet.
- These characteristics only guarantees the same relocate port number.
For example, the combination of SCKx_0 and SOTx_1 is not guaranteed.
- When the external load capacitance = 50 pF.

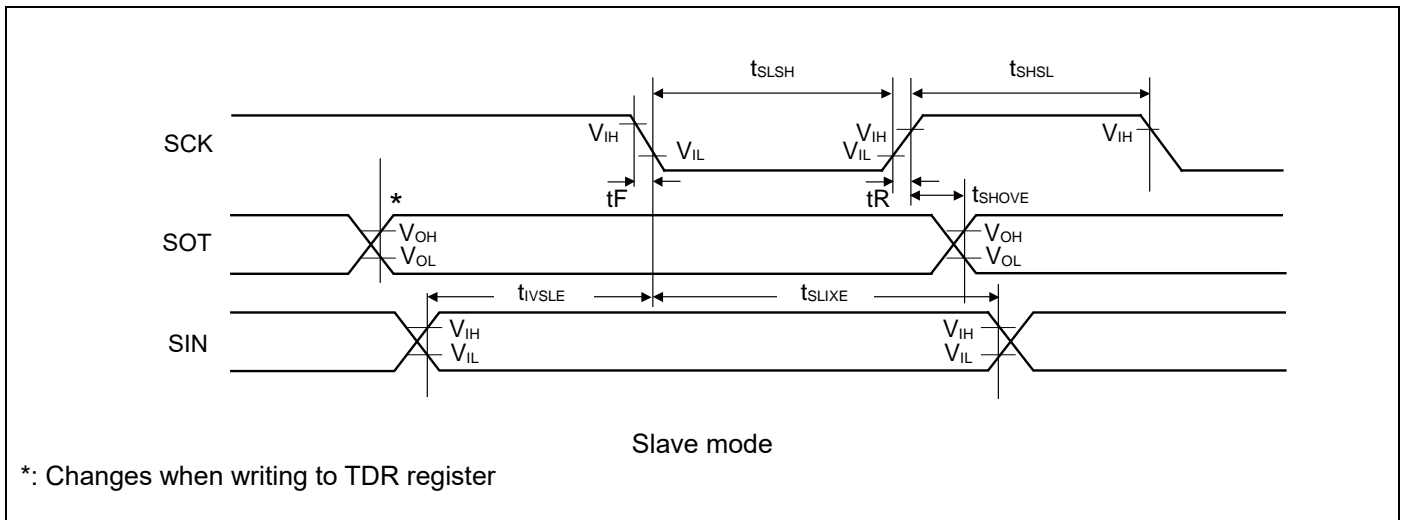
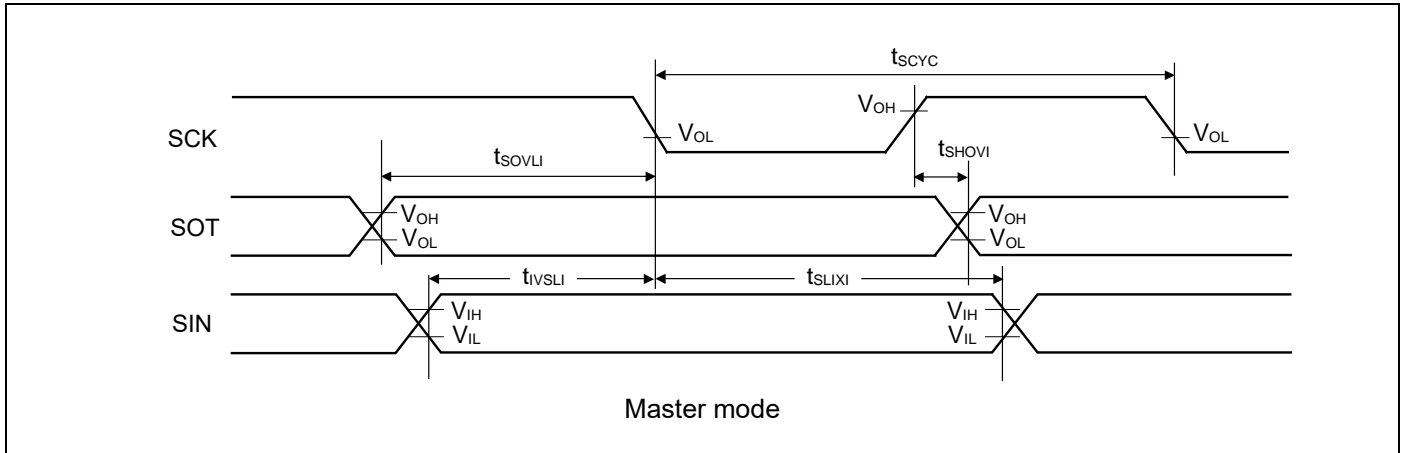

CSIO (SPI = 1, SCINV = 1)

 (V_{CC} = 2.7 V to 5.5 V, V_{SS} = 0 V, T_A = - 40°C to + 85°C)

| Parameter | Symbol | Pin name | Conditions | V _{CC} < 4.5 V | | V _{CC} ≥ 4.5 V | | Unit |
|------------------------------|--------------------|--------------|-------------|-------------------------|-----|-------------------------|------|------|
| | | | | Min | Max | Min | Max | |
| Baud Rate | - | - | - | - | 8 | - | 8 | Mbps |
| Serial clock cycle time | t _{SCYC} | SCKx | Master mode | 4t _{CYCP} | - | 4t _{CYCP} | - | ns |
| SCK ↓ → SOT delay time | t _{SLOVI} | SCKx SOTx | | -30 | +30 | - 20 | + 20 | ns |
| SIN → SCK ↑ setup time | t _{IVSHI} | SCKx SINx | | 50 | - | 30 | - | ns |
| SCK ↑ → SIN hold time | t _{SHIXI} | SCKx SINx | | 0 | - | 0 | - | ns |
| SOT → SCK ↑ delay time | t _{SOVHI} | SCKx SOTx | | 2t _{CYCP} - 30 | - | 2t _{CYCP} - 30 | - | ns |
| Serial clock "L" pulse width | t _{SLSH} | SCKx | Slave mode | 2t _{CYCP} - 10 | - | 2t _{CYCP} - 10 | - | ns |
| Serial clock "H" pulse width | t _{SHSL} | SCKx | | t _{CYCP} + 10 | - | t _{CYCP} + 10 | - | ns |
| SCK ↓ → SOT delay time | t _{SLOVE} | SCKx SOTx | | - | 50 | - | 30 | ns |
| SIN → SCK ↑ setup time | t _{IVSHE} | SCKx SINx | | 10 | - | 10 | - | ns |
| SCK ↑ → SIN hold time | t _{SHIXE} | SCKx SINx | | 20 | - | 20 | - | ns |
| SCK fall time | t _F | SCKx | | - | 5 | - | 5 | ns |
| SCK rise time | t _R | SCKx | | - | 5 | - | 5 | ns |

Notes:

- The above characteristics apply to CLK synchronous mode.
- t_{CYCP} indicates the APB bus clock cycle time.
About the APB bus number which Multi-function Serial is connected to, see "8. Block Diagram" in this datasheet.
- These characteristics only guarantee the same relocate port number.
For example, the combination of SCKx_0 and SOTx_1 is not guaranteed.
- When the external load capacitance = 50 pF.

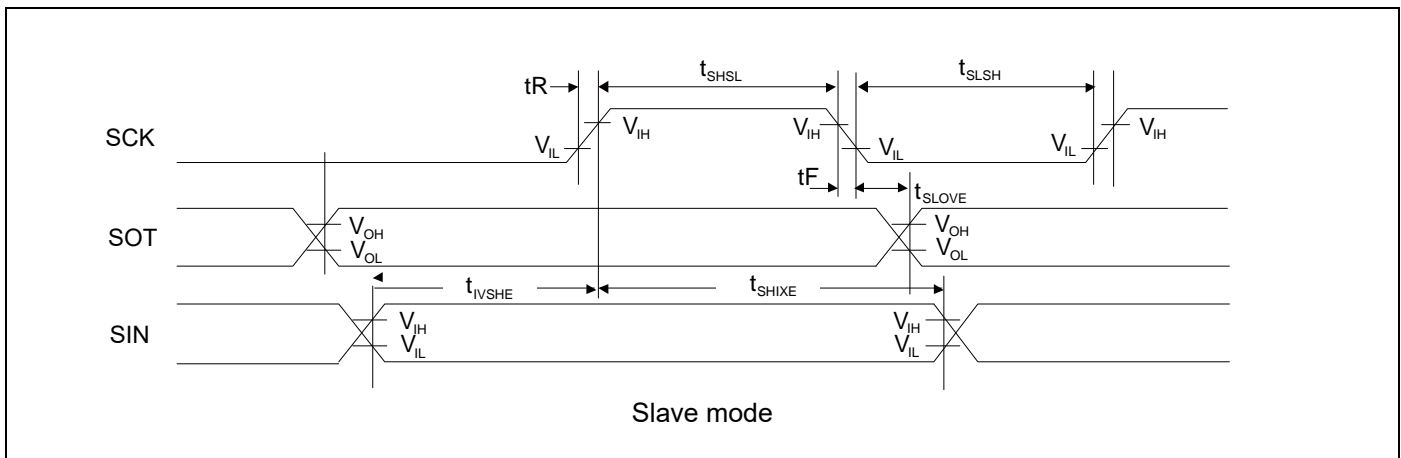
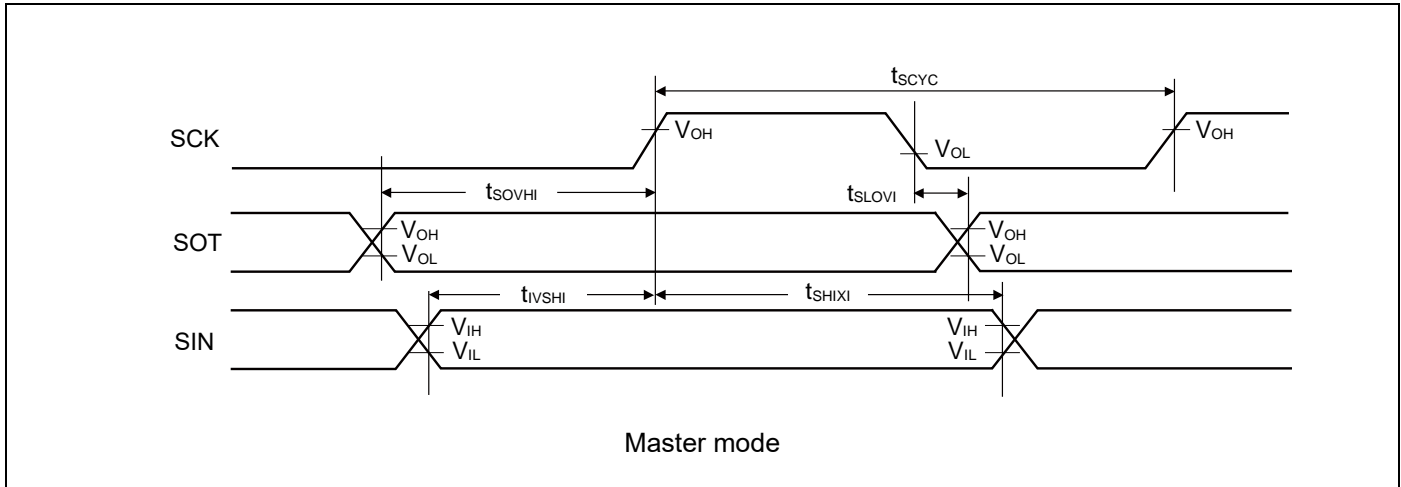

UART external clock input (EXT = 1)

(V_{CC} = 2.7 V to 5.5 V, V_{SS} = 0 V, T_A = - 40°C to + 85°C)

| Parameter | Symbol | Conditions | Min | Max | Unit | Remarks |
|------------------------------|-------------------|------------------------|------------------------|-----|------|---------|
| Serial clock "L" pulse width | t _{SLSH} | C _L = 50 pF | t _{CYCP} + 10 | - | ns | |
| Serial clock "H" pulse width | t _{SHSL} | | t _{CYCP} + 10 | - | ns | |
| SCK fall time | t _F | | - | 5 | ns | |
| SCK rise time | t _R | | - | 5 | ns | |

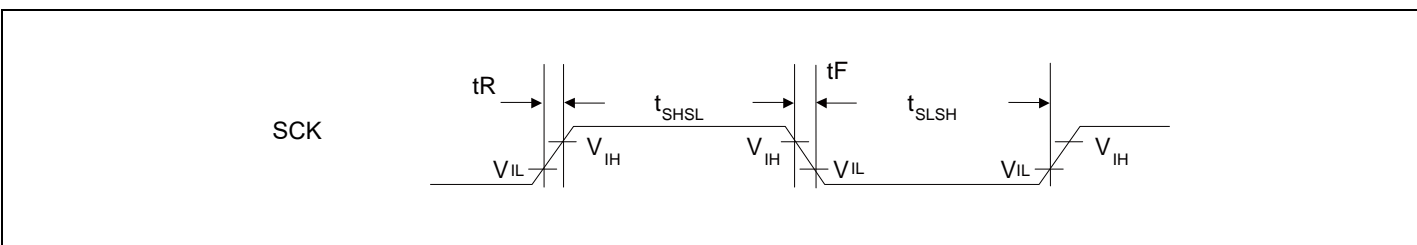

12.4.11 External Input Timing

(V_{CC} = 2.7 V to 5.5 V, V_{SS} = 0 V, T_A = - 40°C to + 85°C)

| Parameter | Symbol | Pin name | Conditions | Value | | Unit | Remarks |
|-------------------|--------------------------------------|----------------|------------------------------------|--|-----|------|-----------------------------|
| | | | | Min | Max | | |
| Input pulse width | t _{INH} t _{INL} | ADTG | - | 2t _{CYCP} ^{*1} | - | ns | A/D converter trigger input |
| | | FRCKx | | | | | Free-run timer input clock |
| | | ICxx | | | | | Input capture |
| | | DTTixX | - | 2t _{CYCP} ^{*1} | - | ns | Wave form generator |
| | | INTxx, NMIX | Except Timer mode, Stop mode | 2t _{CYCP} + 100 ^{*1} | - | ns | External interrupt NMI |
| | Timer mode, Stop mode | 500 | - | ns | | | |

*1: t_{CYCP} indicates the APB bus clock cycle time.

About the APB bus number which the A/D converter, Multi-function Timer, External interrupt are connected to, see "8. Block Diagram" in this datasheet.

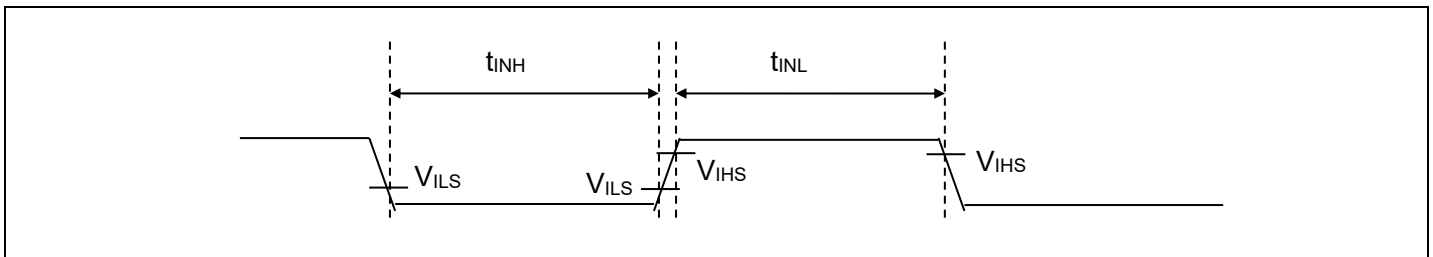

12.4.12 Quadrature Position/Revolution Counter timing

(V_{CC} = 2.7 V to 5.5 V, V_{SS} = 0 V, T_A = - 40°C to + 85°C)

| Parameter | Symbol | Conditions | Value | | Unit |
|--|-------------------|----------------------|-----------------------|-----|------|
| | | | Min | Max | |
| AIN pin "H" width | t _{AHL} | - | 2t _{CYCP} *1 | - | ns |
| AIN pin "L" width | t _{ALL} | - | | | |
| BIN pin "H" width | t _{BHL} | - | | | |
| BIN pin "L" width | t _{BLL} | - | | | |
| BIN rise time from AIN pin "H" level | t _{AUBU} | PC_Mode2 or PC_Mode3 | | | |
| AIN fall time from BIN pin "H" level | t _{BUAD} | PC_Mode2 or PC_Mode3 | | | |
| BIN fall time from AIN pin "L" level | t _{ADBD} | PC_Mode2 or PC_Mode3 | | | |
| AIN rise time from BIN pin "L" level | t _{BDAU} | PC_Mode2 or PC_Mode3 | | | |
| AIN rise time from BIN pin "H" level | t _{BUAU} | PC_Mode2 or PC_Mode3 | | | |
| BIN fall time from AIN pin "H" level | t _{AUBD} | PC_Mode2 or PC_Mode3 | | | |
| AIN fall time from BIN pin "L" level | t _{BDAD} | PC_Mode2 or PC_Mode3 | | | |
| BIN rise time from AIN pin "L" level | t _{ADBU} | PC_Mode2 or PC_Mode3 | | | |
| ZIN pin "H" width | t _{ZHL} | QCR:CGSC="0" | | | |
| ZIN pin "L" width | t _{ZLL} | QCR:CGSC="0" | | | |
| AIN/BIN rise and fall time from determined ZIN level | t _{ZABE} | QCR:CGSC="1" | | | |
| Determined ZIN level from AIN/BIN rise and fall time | t _{ABEZ} | QCR:CGSC="1" | | | |

*1: t_{CYCP} indicates the APB bus clock cycle time. About the APB bus number which the Quadrature Position/Revolution Counter is connected to, see "8. Block Diagram" in this datasheet.

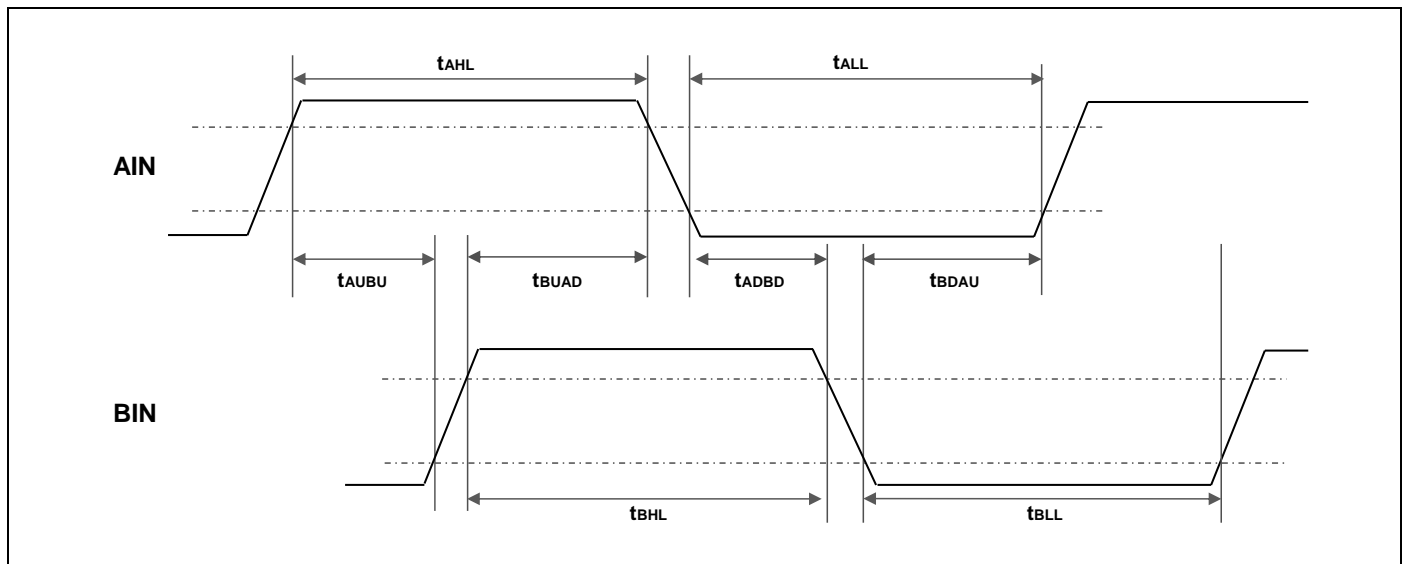

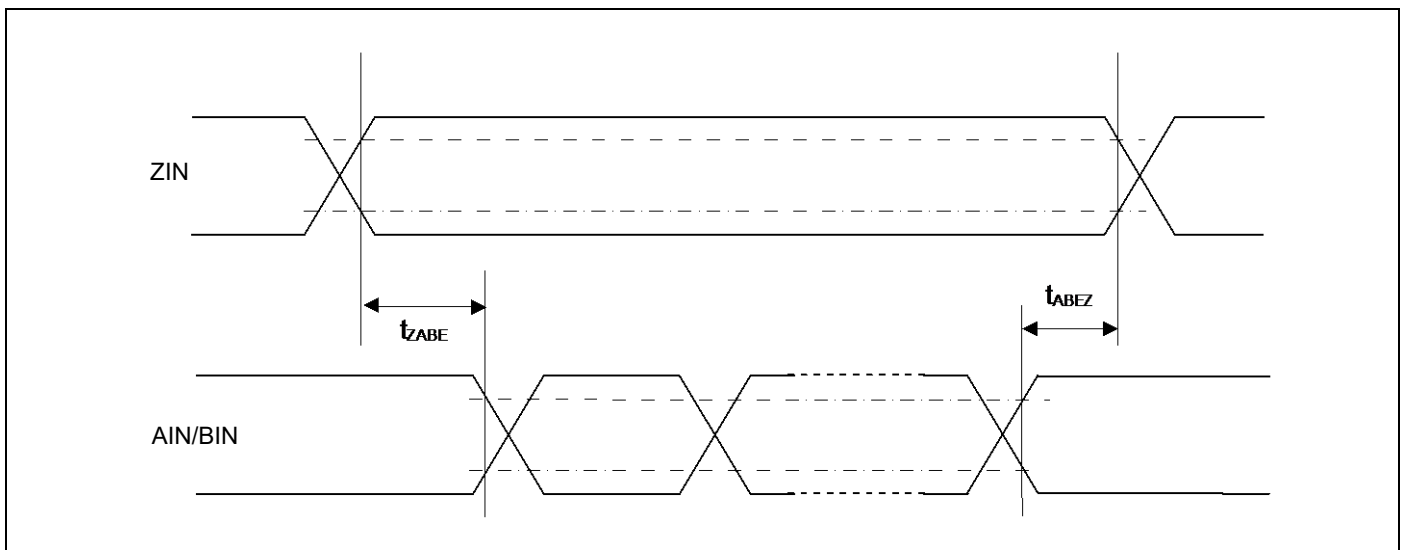
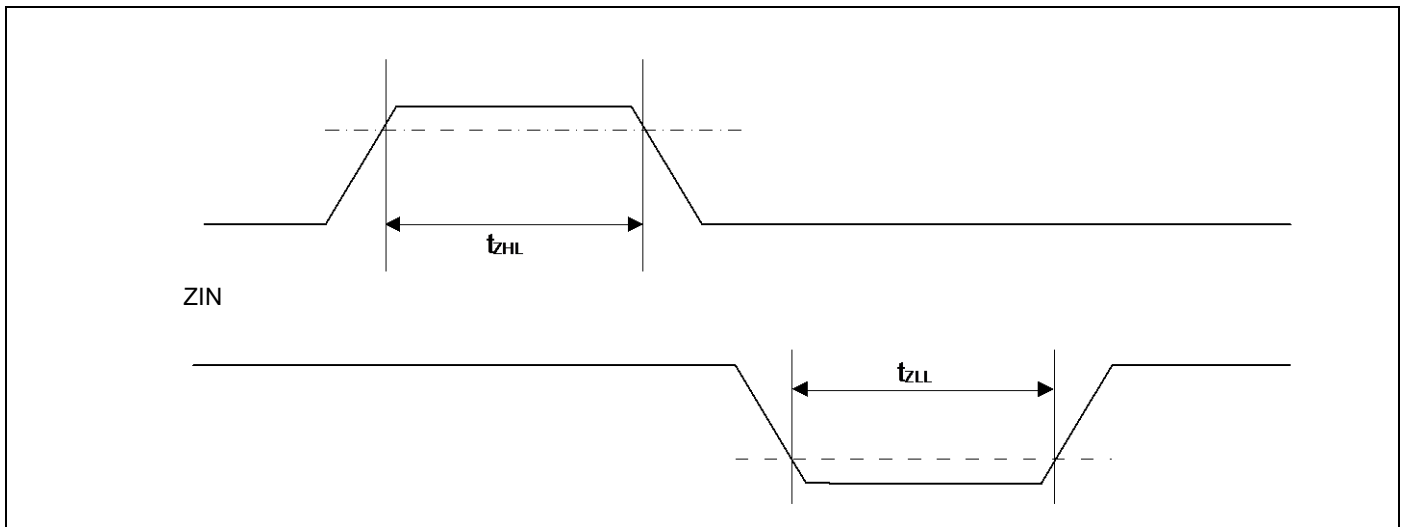
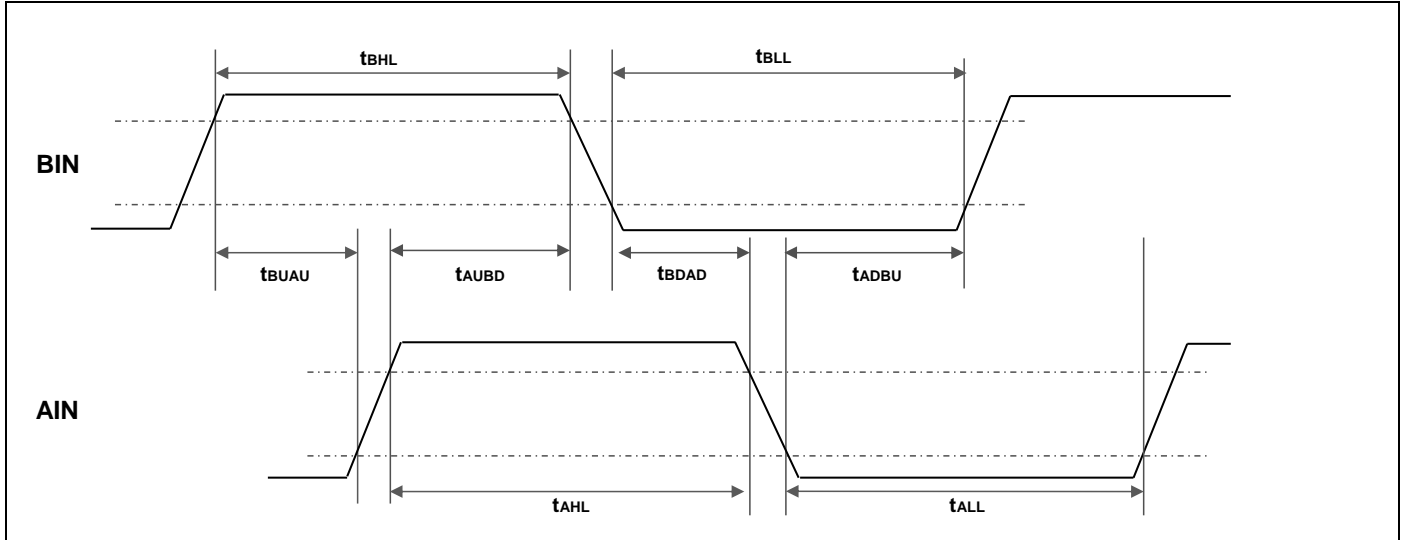

12.4.13 I²C Timing

(V_{CC} = 2.7 V to 5.5 V, V_{SS} = 0 V, T_A = - 40°C to + 85°C)

| Parameter | Symbol | Conditions | Standard-mode | | Fast-mode | | Unit | Remarks |
|--|--------------------|---|---------------|------------------------------------|-----------|------------------------------------|------|---------|
| | | | Min | Max | Min | Max | | |
| SCL clock frequency | F _{SCL} | C _L = 50 pF, R = (V _p /I _{OL})* ¹ | 0 | 100 | 0 | 400 | kHz | |
| (Repeated) START condition hold time SDA ↓ → SCL ↓ | t _{HDSTA} | | 4.0 | - | 0.6 | - | μs | |
| SCLclock "L" width | t _{LOW} | | 4.7 | - | 1.3 | - | μs | |
| SCLclock "H" width | t _{HIGH} | | 4.0 | - | 0.6 | - | μs | |
| (Repeated) START setup time SCL ↑ → SDA ↓ | t _{SUSTA} | | 4.7 | - | 0.6 | - | μs | |
| Data hold time SCL ↓ → SDA ↓ ↑ | t _{HDDAT} | | 0 | 3.45* ² | 0 | 0.9* ³ | μs | |
| Data setup time SDA ↓ ↑ → SCL ↑ | t _{SUDAT} | | 250 | - | 100 | - | ns | |
| STOP condition setup time SCL ↑ → SDA ↑ | t _{SUSTO} | | 4.0 | - | 0.6 | - | μs | |
| Bus free time between "STOP condition" and "START condition" | t _{BUF} | | 4.7 | - | 1.3 | - | μs | |
| Noise filter | t _{SP} | | - | 2 t _{CYCP} * ⁴ | - | 2 t _{CYCP} * ⁴ | ns | |

*1: R and C represent the pull-up resistance and load capacitance of the SCL and SDA lines, respectively.
V_p indicates the power supply voltage of the pull-up resistance and I_{OL} indicates V_{OL} guaranteed current.

*2: The maximum t_{HDDAT} must satisfy that it doesn't extend at least "L" period (t_{LOW}) of device's SCL signal.

*3: Fast-mode I²C bus device can be used on Standard-mode I²C bus system as long as the device satisfies the requirement of "t_{SUDAT} ≥ 250 ns".

*4: t_{CYCP} is the APB bus clock cycle time.

About the APB bus number that I²C is connected to, see "8. Block Diagram" in this datasheet.
To use Standard-mode, set the APB bus clock at 2 MHz or more.
To use Fast-mode, set the APB bus clock at 8 MHz or more.

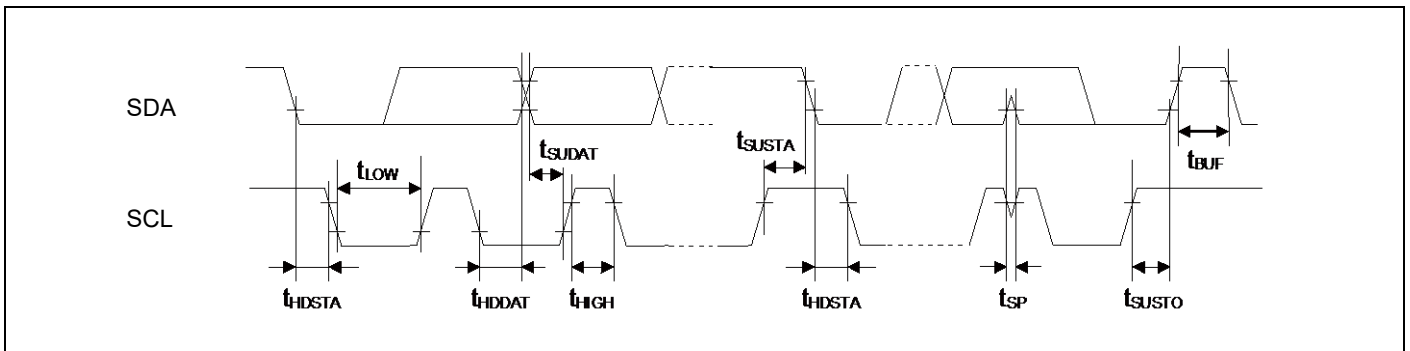

12.4.14 ETM Timing

(V_{CC} = 2.7 V to 5.5 V, V_{SS} = 0 V, T_A = - 40°C to + 85°C)

| Parameter | Symbol | Pin name | Conditions | Value | | Unit | Remarks |
|------------------------------|----------------------|-------------------------|-------------------------|-------|-----|------|---------|
| | | | | Min | Max | | |
| Data hold | t _{ETMH} | TRACECLK TRACED3 - 0 | V _{CC} ≥ 4.5 V | 2 | 9 | ns | |
| | | | V _{CC} < 4.5 V | 2 | 15 | | |
| TRACECLK Frequency | 1/t _{TRACE} | TRACECLK | V _{CC} ≥ 4.5 V | - | 50 | MHz | |
| | | | V _{CC} < 4.5 V | - | 32 | MHz | |
| TRACECLK clock cycle time | t _{TRACE} | | V _{CC} ≥ 4.5 V | 20 | - | ns | |
| | | | V _{CC} < 4.5 V | 31.25 | - | ns | |

Note:

- When the external load capacitance = 50 pF.

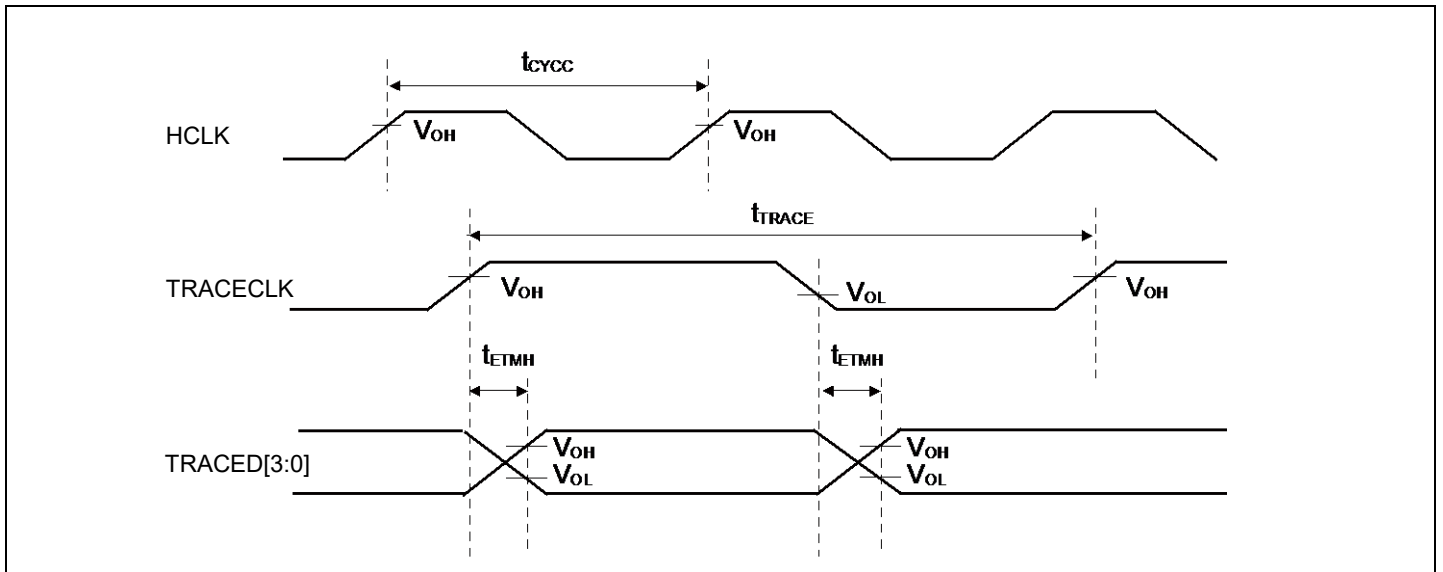

12.4.15 JTAG Timing

(Vcc = 2.7 V to 5.5 V, Vss = 0 V, TA = - 40°C to + 85°C)

| Parameter | Symbol | Pin name | Conditions | Value | | Unit | Remarks |
|--------------------|-------------|----------------|----------------------------|-------|-----|------|---------|
| | | | | Min | Max | | |
| TMS,TDI setup time | t_{JTAGS} | TCK TMS,TDI | $V_{cc} \geq 4.5\text{ V}$ | 15 | - | ns | |
| | | | $V_{cc} < 4.5\text{ V}$ | | | | |
| TMS,TDI hold time | t_{JTAGH} | TCK TMS,TDI | $V_{cc} \geq 4.5\text{ V}$ | 15 | - | ns | |
| | | | $V_{cc} < 4.5\text{ V}$ | | | | |
| TDO delay time | t_{JTAGD} | TCK TDO | $V_{cc} \geq 4.5\text{ V}$ | - | 25 | ns | |
| | | | $V_{cc} < 4.5\text{ V}$ | - | 45 | | |

Note:

- When the external load capacitance = 50 pF.

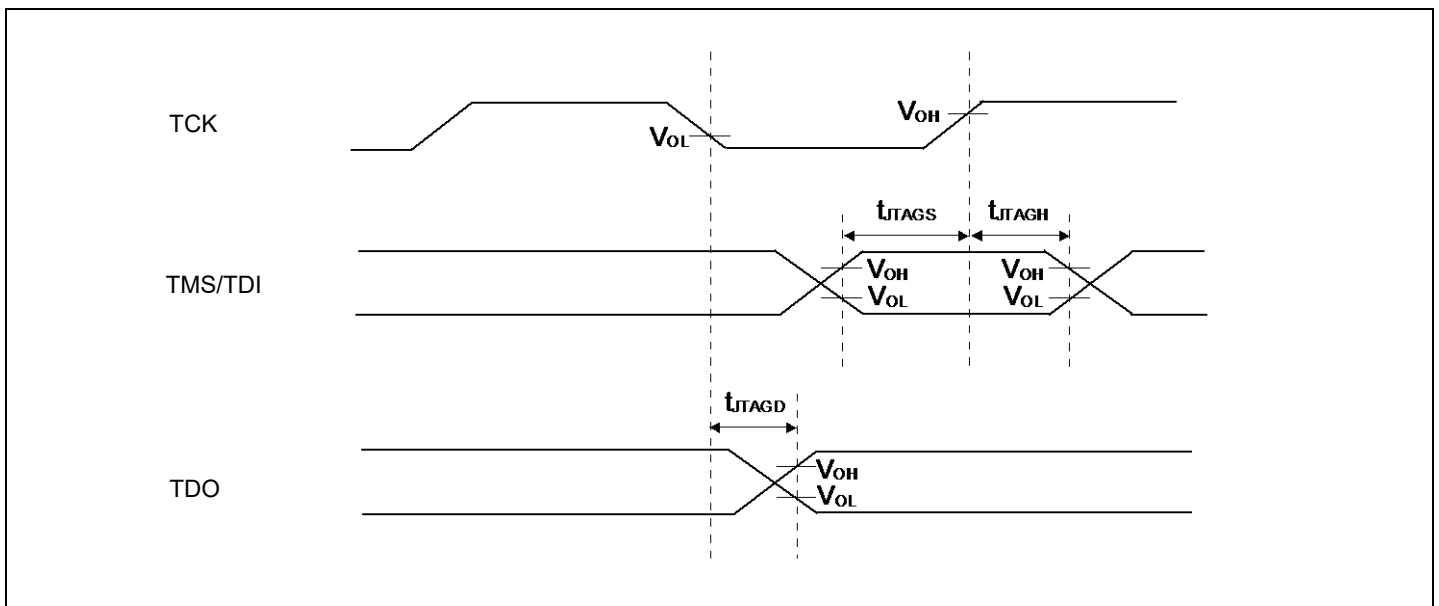

12.5 12-bit A/D Converter

Electrical characteristics for the A/D converter

(V_{CC} = AV_{CC} = 2.7 V to 5.5 V, V_{SS} = AV_{SS} = 0 V, T_A = - 40°C to + 85°C)

| Parameter | Symbol | Pin name | Value | | | Unit | Remarks |
|---|------------------|----------|---------------------|-----------|------------------|------|--------------------------|
| | | | Min | Typ | Max | | |
| Resolution | - | - | - | - | 12 | bit | |
| Integral Nonlinearity | - | - | - | ± 2 | ± 4.5 | LSB | AVRH = 2.7 V to 5.5 V |
| Differential Nonlinearity | - | - | - | ± 2 | ± 2.5 | LSB | |
| Zero transition voltage | V _{ZT} | ANxx | - | ± 5 | ± 20 | mV | |
| Full-scale transition voltage | V _{FST} | ANxx | - | AVRH ± 10 | AVRH ± 20 | mV | |
| Conversion time | - | - | 1.0 ^{*1} | - | - | μs | |
| | | | 2.666 ^{*1} | - | - | | AV _{CC} < 4.5 V |
| Sampling time | T _s | - | *2 | - | - | ns | AV _{CC} ≥ 4.5 V |
| | | | *2 | - | - | | AV _{CC} < 4.5 V |
| Compare clock cycle ^{*3} | T _{ck} | - | 55.5 | - | 10000 | ns | AV _{CC} ≥ 4.5 V |
| | | | 166.6 ^{*4} | | | | AV _{CC} < 4.5 V |
| State transition time to operation permission | T _{stt} | - | - | - | 2.5 | μs | |
| Analog input capacity | C _{AIN} | - | - | - | 14.5 | pF | |
| Analog input resistance | R _{AIN} | - | - | - | 0.93 | kΩ | AV _{CC} ≥ 4.5 V |
| | | | | | 2.04 | | AV _{CC} < 4.5 V |
| Interchannel disparity | - | - | - | - | 4 | LSB | |
| Analog port input leak current | - | ANxx | - | - | 5 | μA | |
| Analog input voltage | - | ANxx | AV _{SS} | - | AVRH | V | |
| Reference voltage | - | AVRH | 2.7 | - | AV _{CC} | V | |

*1: The Conversion time is the value of sampling time(T_s) + compare time(T_c).

The condition of the minimum conversion time is the following.

AV_{CC} ≥ 4.5 V, HCLK=72 MHz sampling time: 0.222 μs compare time: 0.778 μs
 AV_{CC} < 4.5 V, HCLK=54 MHz sampling time: 0.333 μs compare time: 2.333 μs

Ensure that it satisfies the value of the sampling time (T_s) and compare clock cycle (T_{ck}).

For setting of the sampling time and compare clock cycle, see "Chapter 1-1: A/D Converter" in "FM3 Family Peripheral Manual Analog Macro Part".

The registers setting of the A/D Converter are reflected in the operation according to the APB bus clock timing.

The sampling clock and compare clock is generated from the Base clock (HCLK).

About the APB bus number which the A/D Converter is connected to, see "8. Block Diagram" in this datasheet.

*2: A necessary sampling time changes by external impedance.

Ensure that it set the sampling time to satisfy (Equation 1)

*3: The Compare time (T_c) is the value of (Equation 2)

*4: When 12-bit A/D converter is used at AV_{CC}<4.5 V, there is a limitation as follows.

Please set the HCLK frequency under 54 MHz.

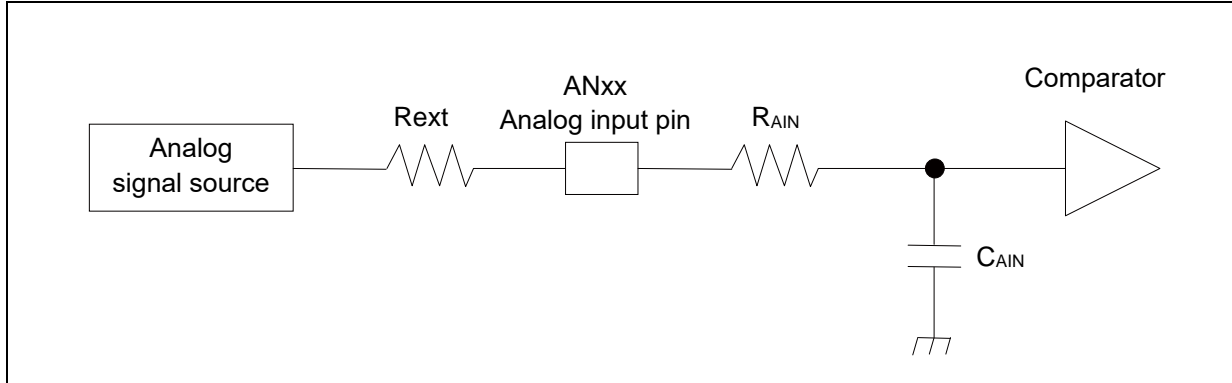

(Equation 1) $T_s \geq (R_{AIN} + R_{ext}) \times C_{AIN} \times 9$

T_s: Sampling time

R_{AIN}: Input resistance of A/D = 0.93 kΩ 4.5 V ≤ AV_{CC} ≤ 5.5 V

Input resistance of A/D = 2.04 kΩ 2.7 V ≤ AV_{CC} < 4.5 V

C_{AIN}: Input capacity of A/D = 14.5 pF 2.7 V ≤ AV_{CC} ≤ 5.5 V

R_{ext}: Output impedance of external circuit

(Equation 2) $T_c = T_{cck} \times 14$

T_c: Compare time

T_{cck}: Compare clock cycle

Definition of 12-bit A/D Converter Terms

- Resolution: Analog variation that is recognized by an A/D converter.
- Integral Nonlinearity: Deviation of the line between the zero-transition point (0b000000000000 ↔ 0b000000000001) and the full-scale transition point (0b111111111110 ↔ 0b111111111111) from the actual conversion characteristics.
- Differential Nonlinearity: Deviation from the ideal value of the input voltage that is required to change the output code by 1 LSB

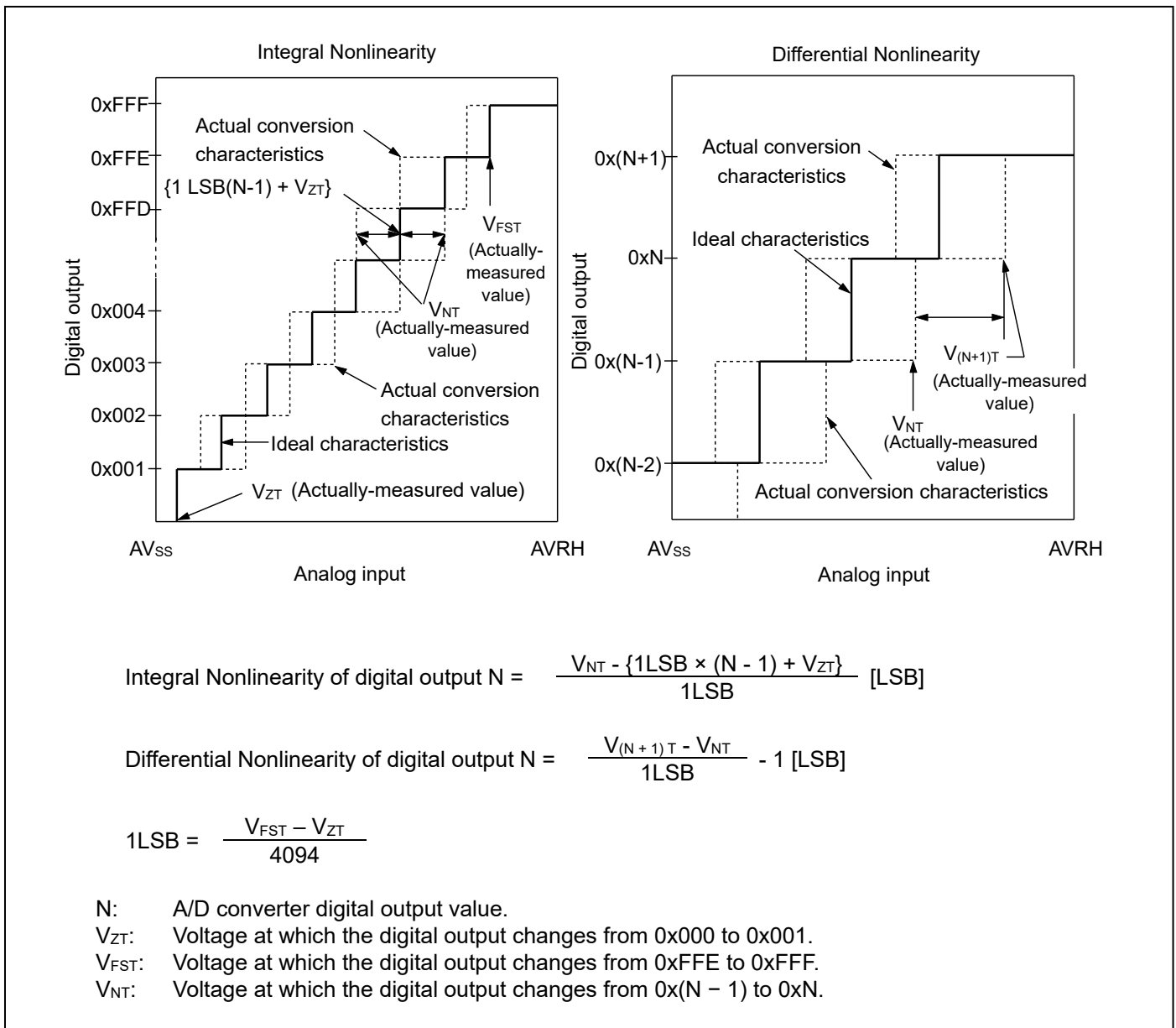

12.6 USB Characteristics

(Vcc = 2.7 V to 5.5 V, USBVcc = 3.0V to 3.6 V, Vss = 0 V, TA = - 40°C to + 85°C)

| Parameter | Symbol | Pin name | Conditions | Value | | Unit | Remarks | |
|------------------------|-------------------------------------|-------------------|------------|---------------------------------------|--------------|------|---------|----|
| | | | | Min | Max | | | |
| Input characteristics | Input High level voltage | V _{IH} | - | 2.0 | USBVcc + 0.3 | V | *1 | |
| | Input Low level voltage | V _{IL} | | Vss - 0.3 | 0.8 | V | *1 | |
| | Differential input sensitivity | V _{DI} | | 0.2 | - | V | *2 | |
| | Different common mode input voltage | V _{CM} | | 0.8 | 2.5 | V | *2 | |
| Output characteristics | Output High level voltage | V _{OH} | UDP0, UDM0 | External pull-down resistance = 15 kΩ | 2.8 | 3.6 | V | *3 |
| | Output Low level voltage | V _{OL} | | External pull-up resistance = 1.5 kΩ | 0.0 | 0.3 | V | *3 |
| | Crossover voltage | V _{CRS} | - | 1.3 | 2.0 | V | *4 | |
| | Rise time | t _{FR} | Full Speed | 4 | 20 | ns | *5 | |
| | Fall time | t _{FF} | Full Speed | 4 | 20 | ns | *5 | |
| | Rise/ fall time matching | t _{FRFM} | Full Speed | 90 | 111.11 | % | *5 | |
| | Output impedance | Z _{DRV} | Full Speed | 28 | 44 | Ω | *6 | |
| | Rise time | t _{LR} | Low Speed | 75 | 300 | ns | *7 | |
| | Fall time | t _{LF} | Low Speed | 75 | 300 | ns | *7 | |
| | Rise/ fall time matching | t _{LRFM} | Low Speed | 80 | 125 | % | *7 | |

*1: The switching threshold voltage of Single-End-Receiver of USB I/O buffer is set as within V_{IL} (Max) = 0.8 V, V_{IH} (Min) = 2.0 V (TTL input standard). There are some hystereses to lower noise sensitivity.

*2: Use differential-Receiver to receive USB differential data signal. Differential-Receiver has 200 mV of differential input sensitivity when the differential data input is within 0.8 V to 2.5 V to the local ground reference level. Above voltage range is the common mode input voltage range.

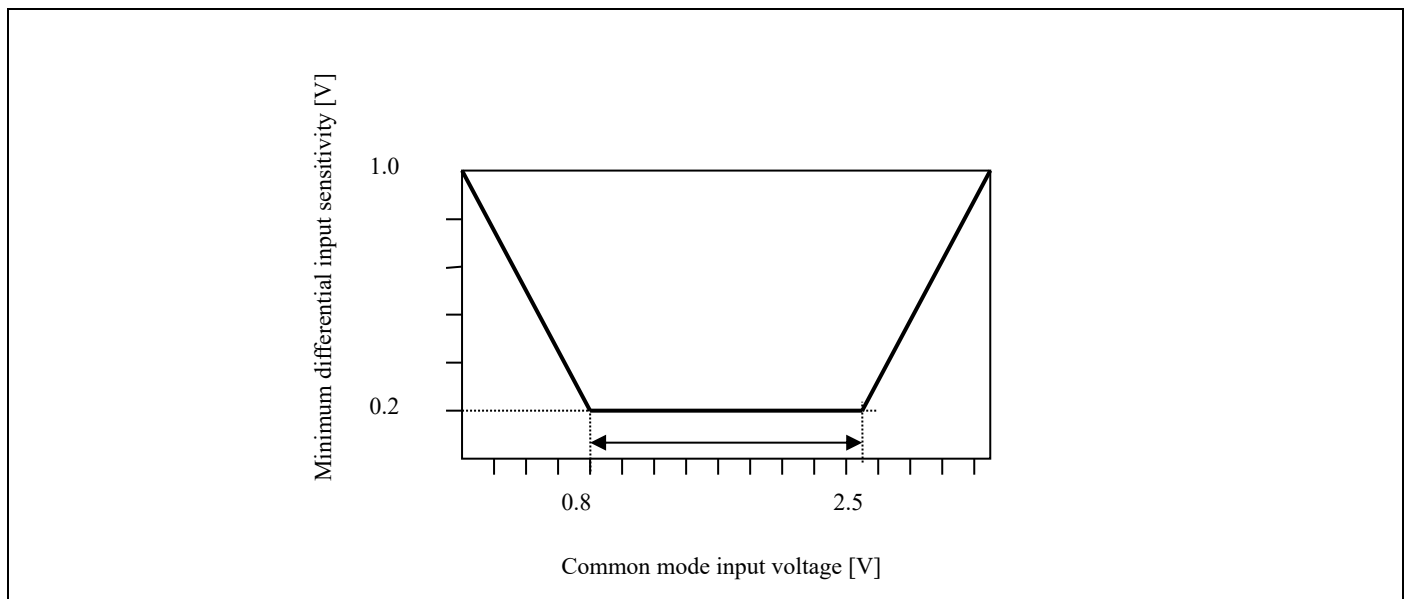

*3: The output drive capability of the driver is below 0.3 V at Low-State (V_{OL}) (to 3.6 V and 1.5 k Ω load), and 2.8 V or above (to the VSS and 1.5 k Ω load) at High-State (V_{OH}).

*4: The cross voltage of the external differential output signal (D + /D -) of USB I/O buffer is within 1.3 V to 2.0 V.

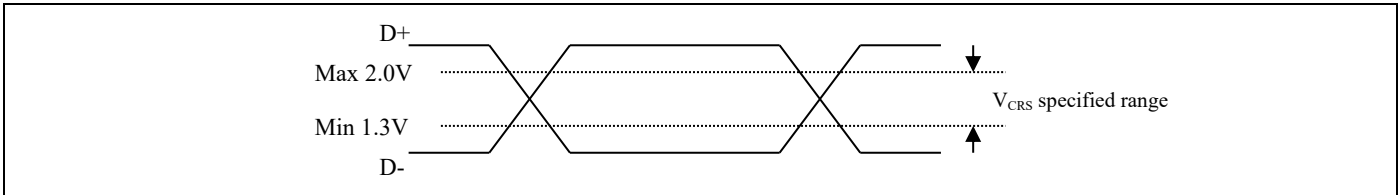

*5: They indicate rise time (T_{rise}) and fall time (T_{fall}) of the full-speed differential data signal. They are defined by the time between 10% and 90% of the output signal voltage. For full-speed buffer, T_r/T_f ratio is regulated as within $\pm 10\%$ to minimize RFI emission.

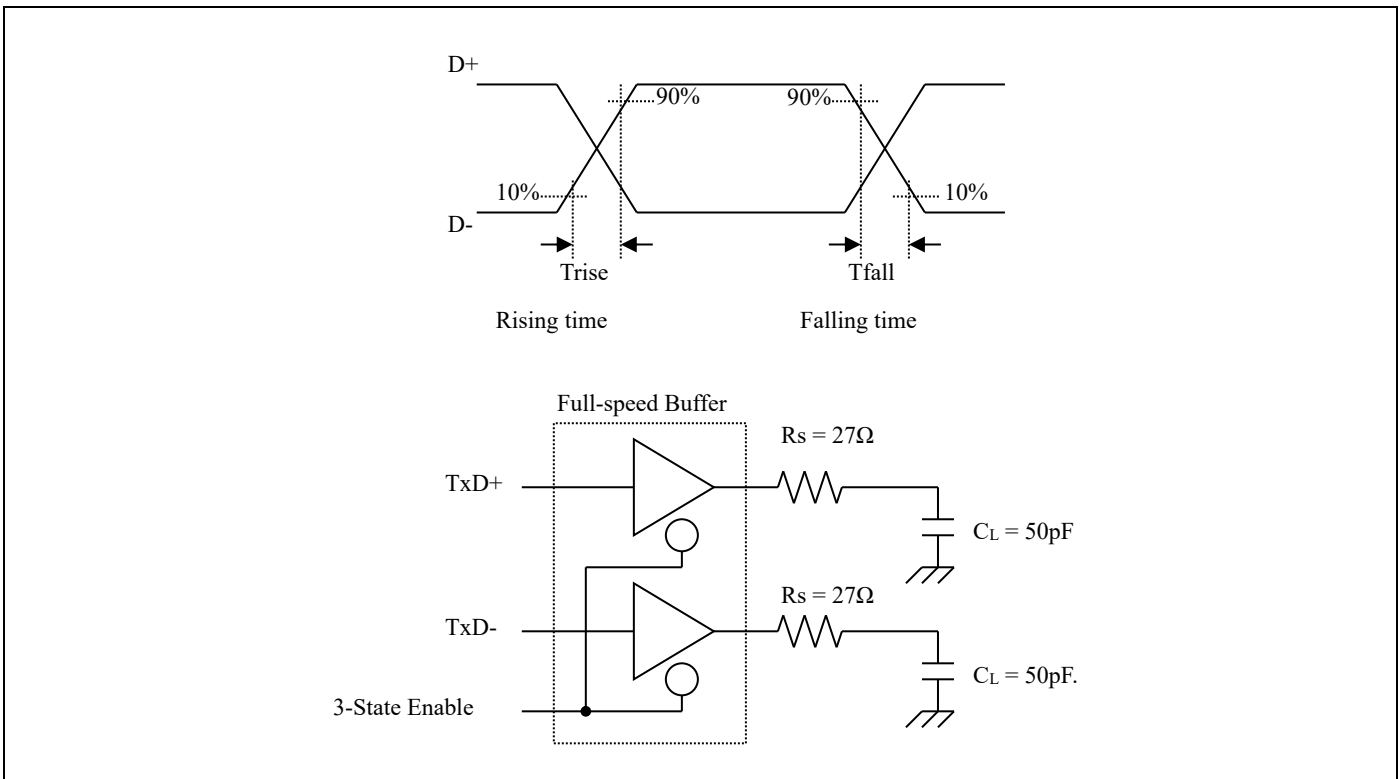

*6: USB Full-speed connection is performed via twist pair cable shield with $90\ \Omega \pm 15\%$ characteristic impedance (Differential Mode).

USB standard defines that output impedance of USB driver must be in range from $28\ \Omega$ to $44\ \Omega$. So, discrete series resistor (R_s) addition is defined in order to satisfy the above definition and keep balance.

When using this USB I/O, use it with $25\ \Omega$ to $30\ \Omega$ (recommendation value $27\ \Omega$) series resistor R_s .

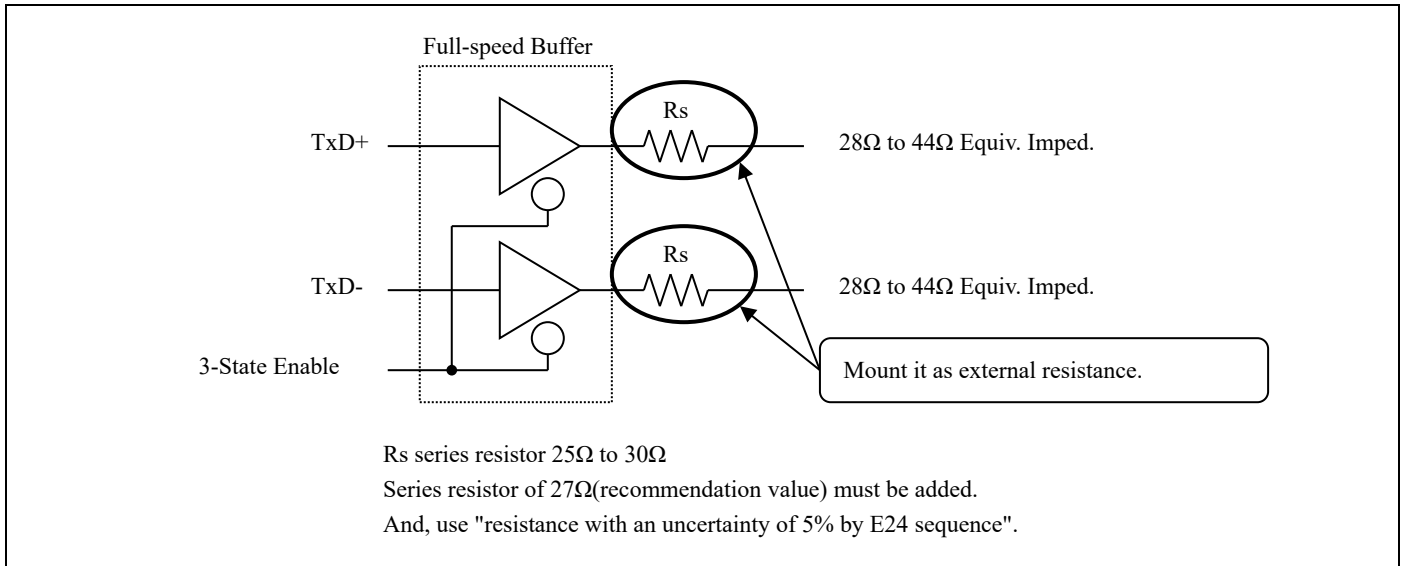

*7: They indicate rise time (T_{rise}) and fall time (T_{fall}) of the low-speed differential data signal. They are defined by the time between 10% and 90% of the output signal voltage.

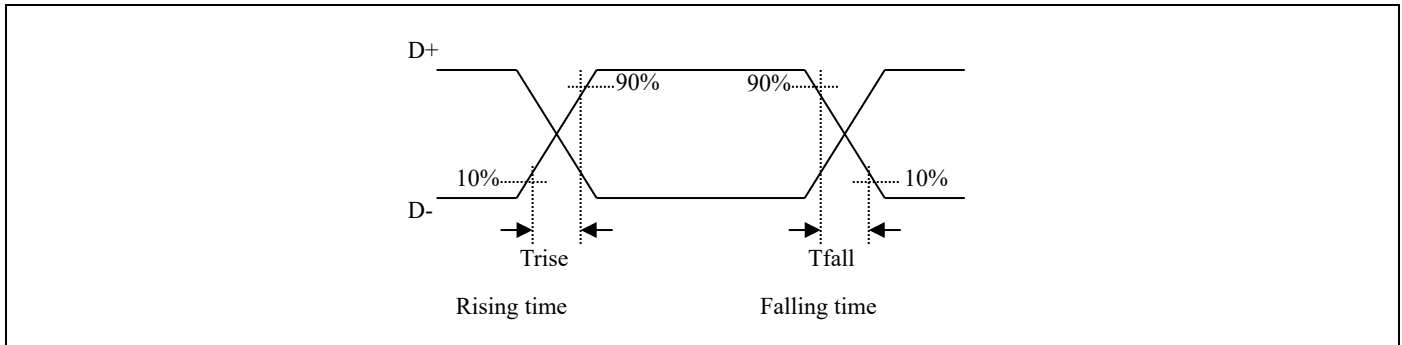

See "Low-Speed Load (Compliance Load)" for conditions of the external load.

Low-Speed Load (Upstream Port Load) - Reference 1

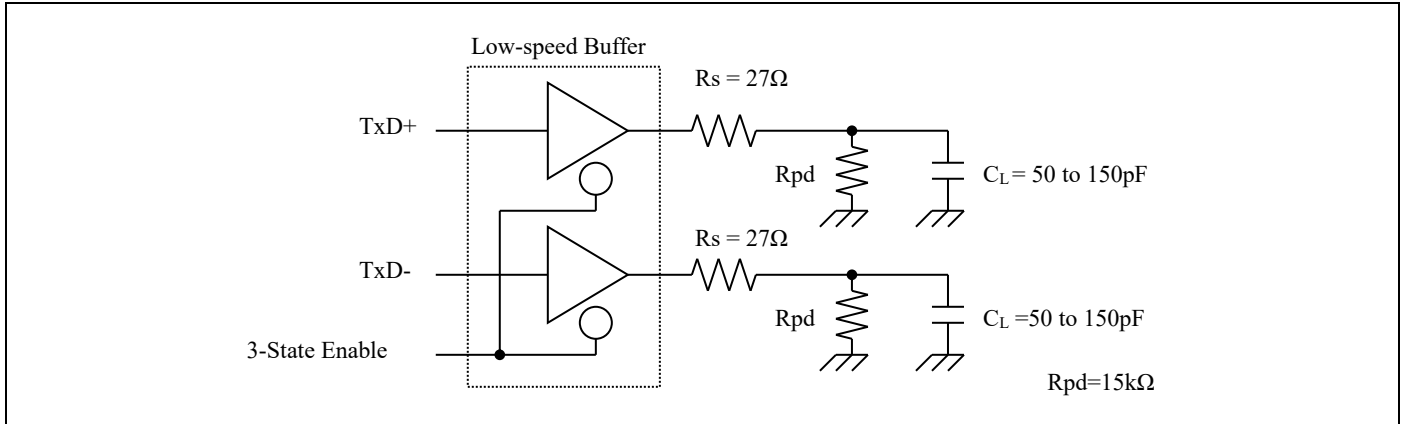

Low-Speed Load (Downstream Port Load) - Reference 2

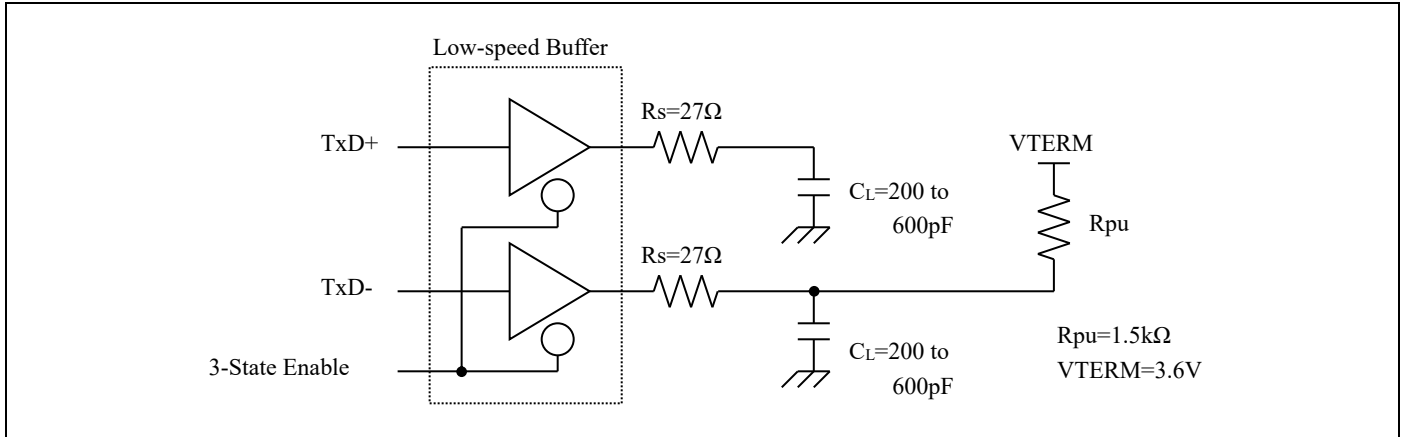

Low-Speed Load (Compliance Load)

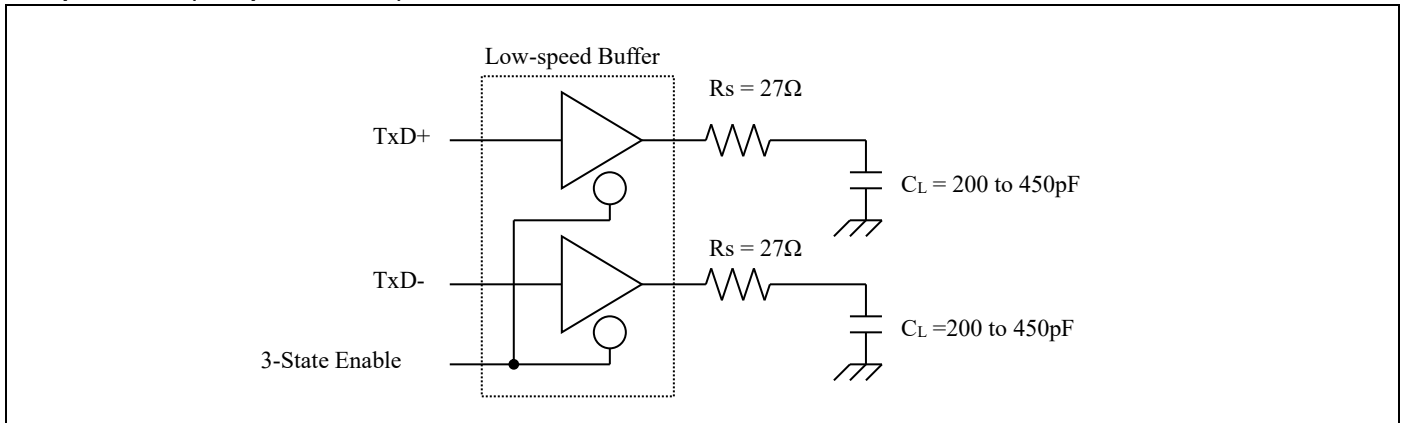

12.7 Low-Voltage Detection Characteristics

12.7.1 Low-Voltage Detection Reset

(T_A = - 40°C to + 85°C)

| Parameter | Symbol | Conditions | Value | | | Unit | Remarks |
|------------------|--------|------------|-------|------|------|------|--------------------|
| | | | Min | Typ | Max | | |
| Detected voltage | VDL | - | 2.20 | 2.40 | 2.60 | V | When voltage drops |
| Released voltage | VDH | - | 2.30 | 2.50 | 2.70 | V | When voltage rises |

12.7.2 Interrupt of Low-Voltage Detection

(T_A = - 40°C to + 85°C)

| Parameter | Symbol | Conditions | Value | | | Unit | Remarks |
|-----------------------------|-------------------|-------------|-------|-----|--|------|--------------------|
| | | | Min | Typ | Max | | |
| Detected voltage | VDL | SVHI = 0000 | 2.58 | 2.8 | 3.02 | V | When voltage drops |
| Released voltage | VDH | | 2.67 | 2.9 | 3.13 | V | When voltage rises |
| Detected voltage | VDL | SVHI = 0001 | 2.76 | 3.0 | 3.24 | V | When voltage drops |
| Released voltage | VDH | | 2.85 | 3.1 | 3.34 | V | When voltage rises |
| Detected voltage | VDL | SVHI = 0010 | 2.94 | 3.2 | 3.45 | V | When voltage drops |
| Released voltage | VDH | | 3.04 | 3.3 | 3.56 | V | When voltage rises |
| Detected voltage | VDL | SVHI = 0011 | 3.31 | 3.6 | 3.88 | V | When voltage drops |
| Released voltage | VDH | | 3.40 | 3.7 | 3.99 | V | When voltage rises |
| Detected voltage | VDL | SVHI = 0100 | 3.40 | 3.7 | 3.99 | V | When voltage drops |
| Released voltage | VDH | | 3.50 | 3.8 | 4.10 | V | When voltage rises |
| Detected voltage | VDL | SVHI = 0111 | 3.68 | 4.0 | 4.32 | V | When voltage drops |
| Released voltage | VDH | | 3.77 | 4.1 | 4.42 | V | When voltage rises |
| Detected voltage | VDL | SVHI = 1000 | 3.77 | 4.1 | 4.42 | V | When voltage drops |
| Released voltage | VDH | | 3.86 | 4.2 | 4.53 | V | When voltage rises |
| Detected voltage | VDL | SVHI = 1001 | 3.86 | 4.2 | 4.53 | V | When voltage drops |
| Released voltage | VDH | | 3.96 | 4.3 | 4.64 | V | When voltage rises |
| LVD stabilization wait time | T _{LVDW} | - | - | - | 2040 × t _{cycp} ^{*1} | μs | |

*1: t_{CYCP} indicates the APB2 bus clock cycle time.

12.8 Flash Memory Write/Erase Characteristics

12.8.1 Write / Erase time

(V_{CC} = 2.7 V to 5.5 V, T_A = - 40°C to + 85°C)

| Parameter | | Value | | Unit | Remarks |
|-------------------------------|--------------|-------------------|-------------------|------|---|
| | | Typ ^{*1} | Max ^{*1} | | |
| Sector erase time | Large Sector | 1.6 | 7.5 | s | Includes write time prior to internal erase |
| | Small Sector | 0.4 | 2.1 | | |
| Half word (16 bit) write time | | 25 | 400 | μs | Not including system-level overhead time. |
| Chip erase time | | 16 | 76.8 | s | Includes write time prior to internal erase |

*1: The typical value is immediately after shipment, the maximum value is guarantee value under 100,000 cycle of erase/write.

12.8.2 Erase/write cycles and data hold time

| Erase/write cycles (cycle) | Data hold time (year) | Remarks |
|----------------------------|-----------------------|---------|
| 1,000 | 20 ^{*1} | |
| 10,000 | 10 ^{*1} | |
| 100,000 | 5 ^{*1} | |

*1: At average + 85°C

12.9 Return Time from Low-Power Consumption Mode

12.9.1 Return Factor: Interrupt

The return time from Low-Power consumption mode is indicated as follows. It is from receiving the return factor to starting the program operation.

Return Count Time

(V_{CC} = 2.7 V to 5.5 V, T_A = - 40°C to + 85°C)

| Parameter | Symbol | Value | | Unit | Remarks |
|---|--------|-------------------|--------|------|---------|
| | | Typ | Max *1 | | |
| SLEEP mode | Ticnt | t _{CYCC} | | ns | |
| High-speed CR TIMER mode, Main TIMER mode, PLL TIMER mode | | 33 | 100 | μs | |
| Low-speed CR TIMER mode | | 445 | 1061 | μs | |
| Sub TIMER mode | | 445 | 1061 | μs | |
| STOP mode | | 445 | 1061 | μs | |

*1: The maximum value depends on the accuracy of built-in CR.

Operation example of return from Low-Power consumption mode (by external interrupt *1)

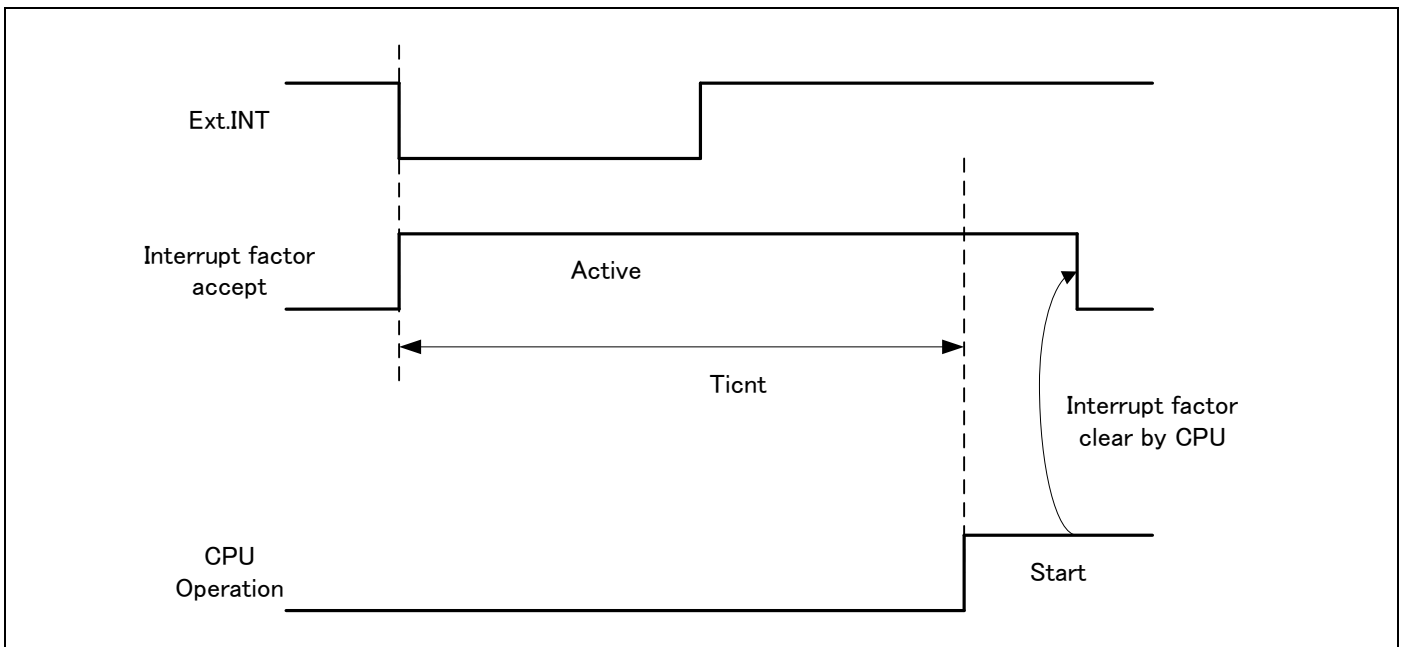

*1: External interrupt is set to detecting fall edge.

Operation example of return from Low-Power consumption mode (by internal resource interrupt *1)

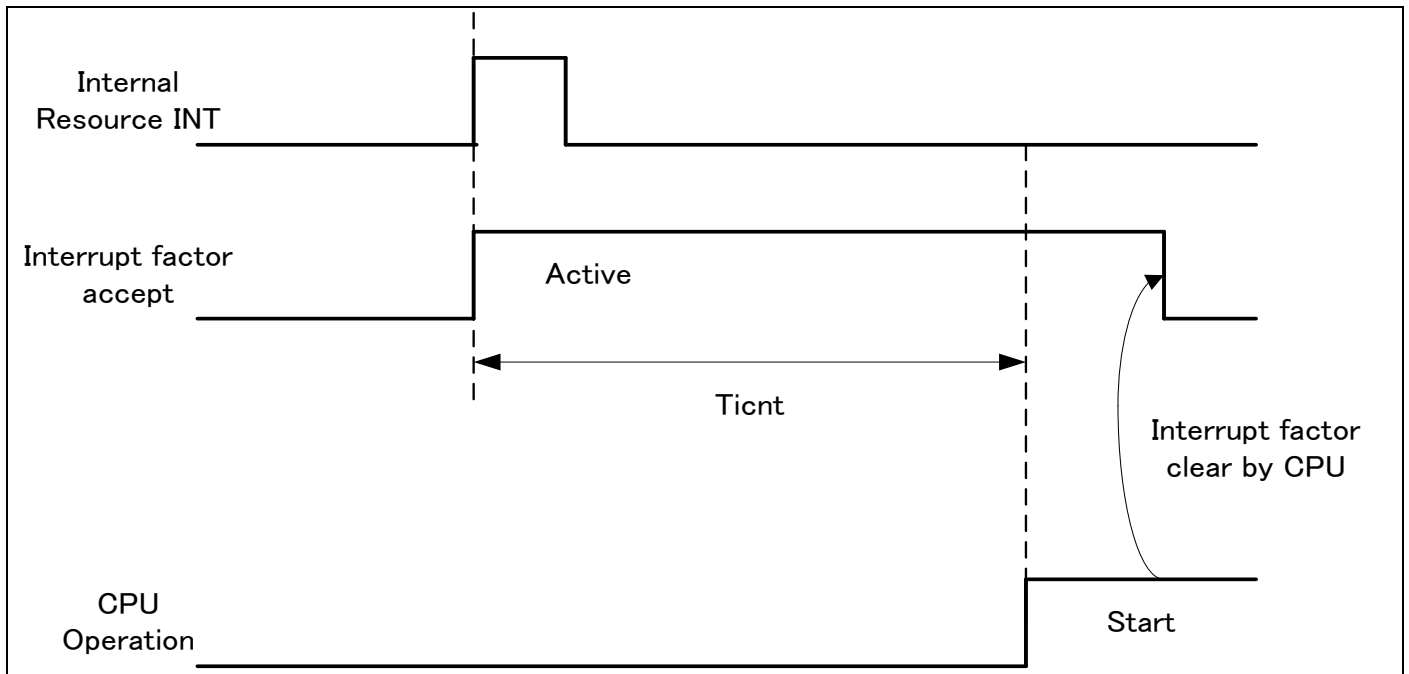

*1: Internal resource interrupt is not included in return factor by the kind of Low-Power consumption mode.

Notes:

- The return factor is different in each Low-Power consumption modes. See "Chapter 6: Low Power Consumption Mode" and "Operations of Standby Modes" in FM3 Family Peripheral Manual about the return factor from Low-Power consumption mode.
- When interrupt recoveries, the operation mode that CPU recoveries depend on the state before the Low-Power consumption mode transition. See "Chapter 6: Low Power Consumption Mode" in "FM3 Family Peripheral Manual"

12.9.2 Return Factor: Reset

The return time from Low-Power consumption mode is indicated as follows. It is from releasing reset to starting the program operation.

Return Count Time

(V_{CC} = 2.7 V to 5.5 V, T_A = - 40°C to + 85°C)

| Parameter | Symbol | Value | | Unit | Remarks |
|---|--------|-------|--------|------|---------|
| | | Typ | Max *1 | | |
| SLEEP mode | Trcnt | 82 | 181 | μs | |
| High-speed CR TIMER mode, Main TIMER mode, PLL TIMER mode | | 82 | 181 | μs | |
| Low-speed CR TIMER mode | | 431 | 1003 | μs | |
| Sub TIMER mode | | 431 | 1003 | μs | |
| STOP mode | | 431 | 1003 | μs | |

*1: The maximum value depends on the accuracy of built-in CR.

Operation example of return from Low-Power consumption mode (by INITX)

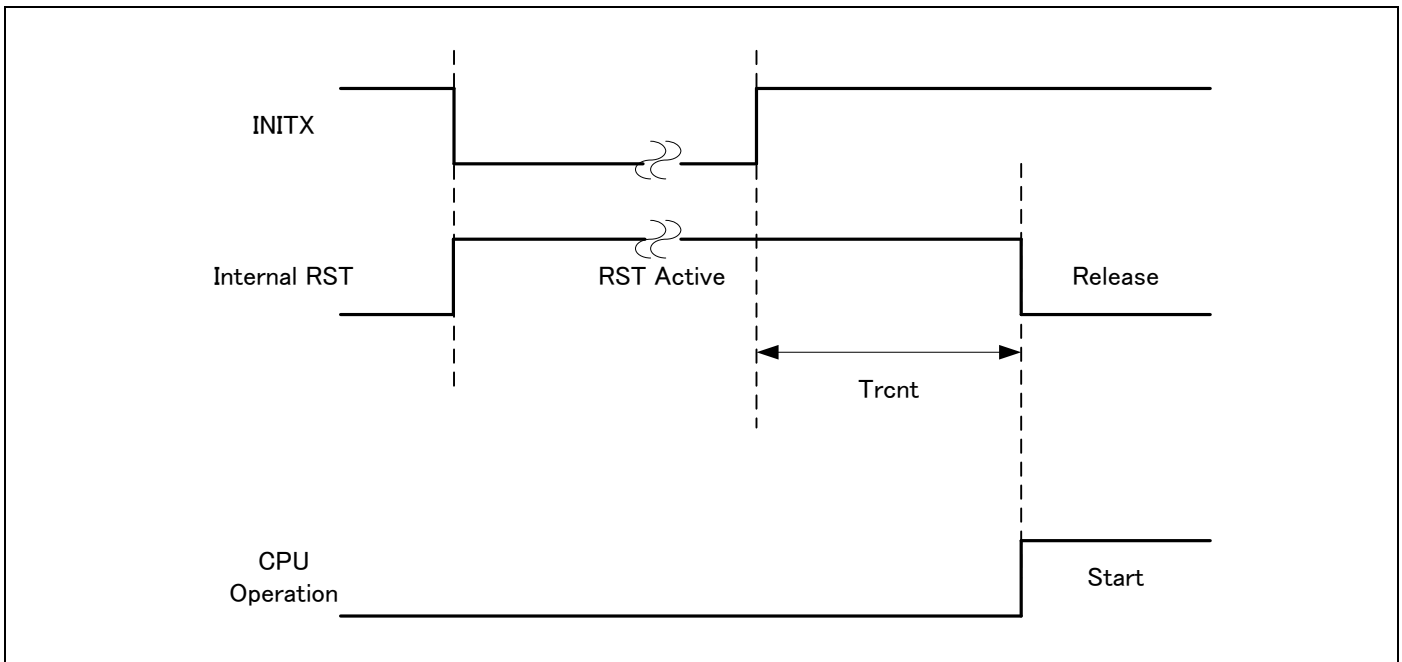

Operation example of return from low power consumption mode (by internal resource reset^{*1})

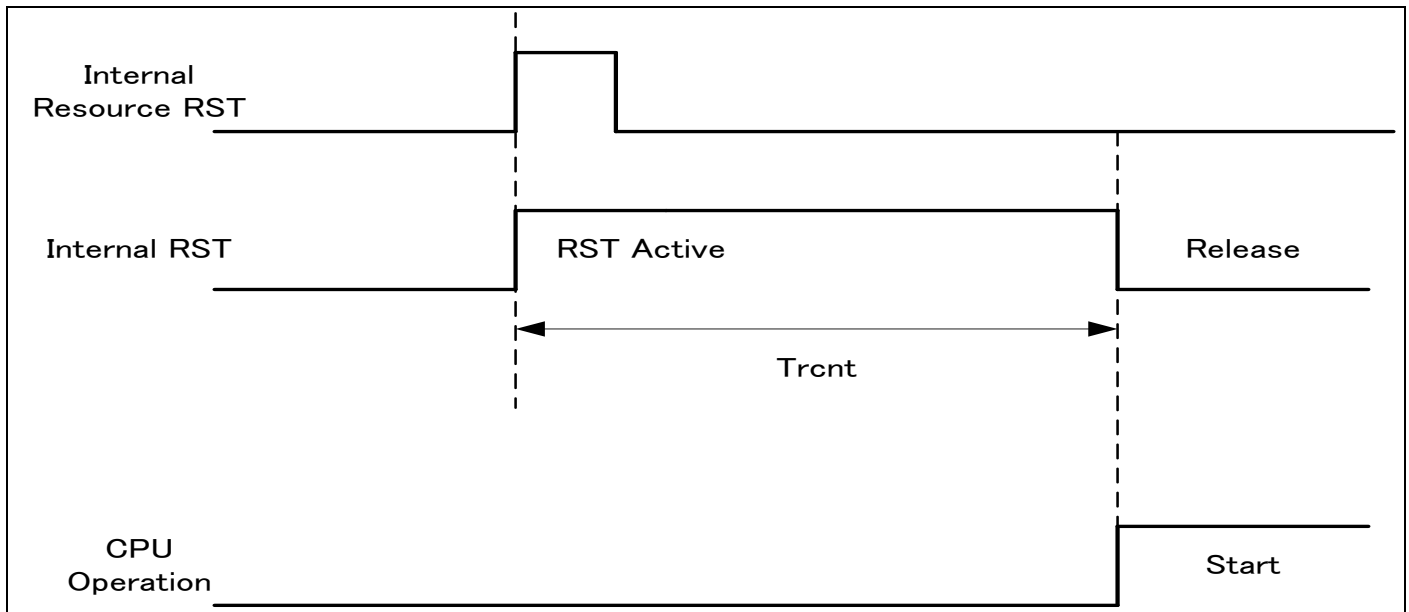

*1: Internal resource reset is not included in return factor by the kind of Low-Power consumption mode.

Notes:

- The return factor is different in each Low-Power consumption modes. See "Chapter 6: Low Power Consumption Mode" and "Operations of Standby Modes" in FM3 Family Peripheral Manual.
- When interrupt recoveries, the operation mode that CPU recoveries depend on the state before the Low-Power consumption mode transition. See "Chapter 6: Low Power Consumption Mode" in "FM3 Family Peripheral Manual"
- The time during the power-on reset/low-voltage detection reset is excluded. See "12.4.7. Power-on Reset Timing 12.4. AC Characteristics in 12. Electrical Characteristics" for the detail on the time during the power-on reset/low -voltage detection reset
- When in recovery from reset, CPU changes to the high-speed CR run mode. When using the main clock or the PLL clock, it is necessary to add the main clock oscillation stabilization wait time or the main PLL clock stabilization wait time.
- The internal resource reset means the watchdog reset and the CSV reset.

13. Example of Characteristic

Power supply current (PLL run mode, PLL sleep mode)

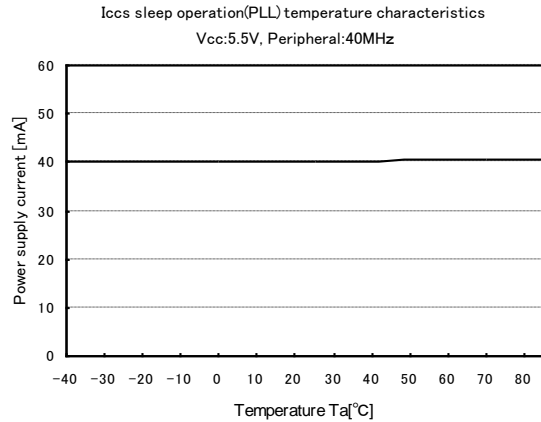
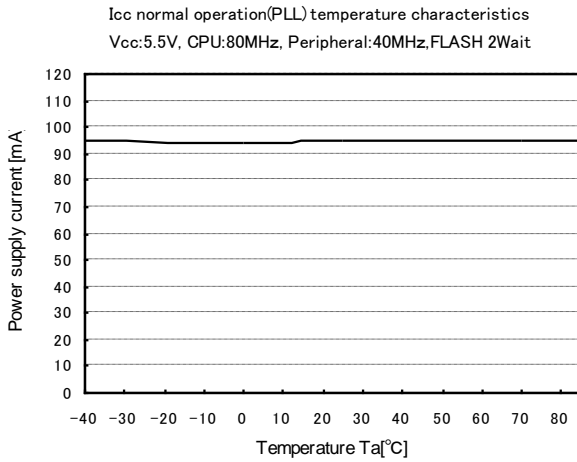

Power supply current (Sub run mode)

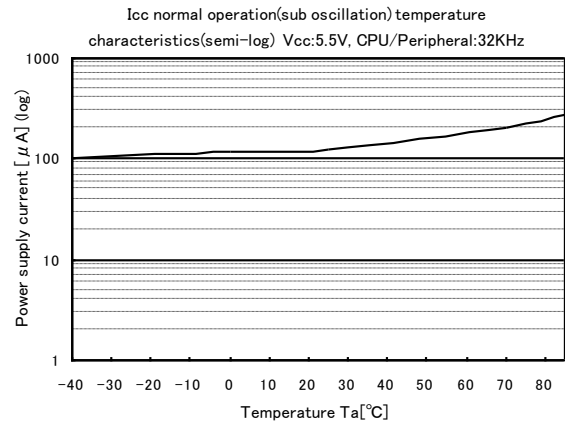
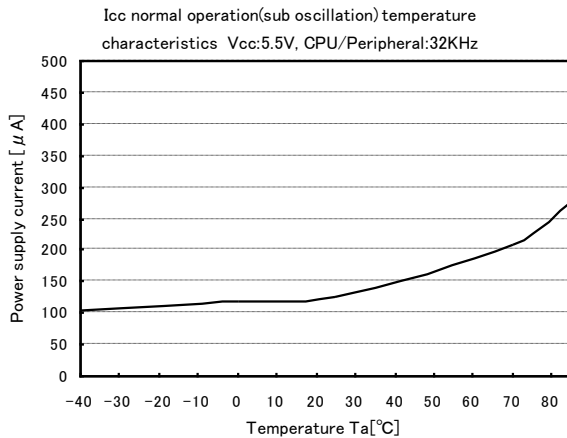

Power supply current (Sub sleep mode)

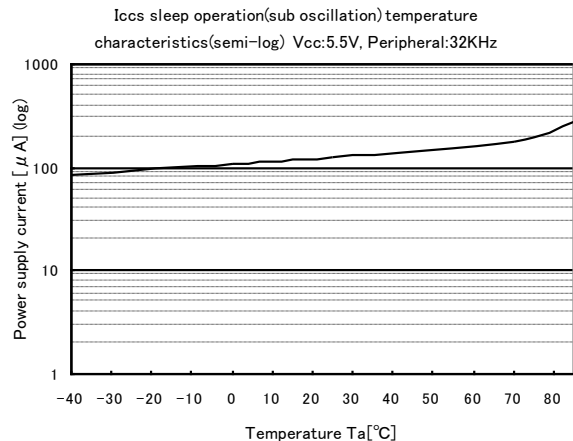
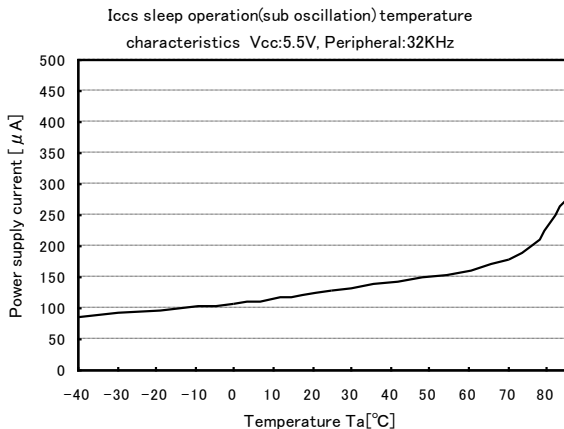

Power supply current (Sub timer mode)

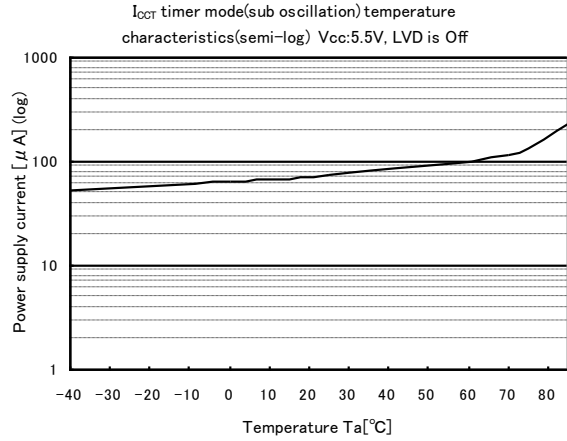
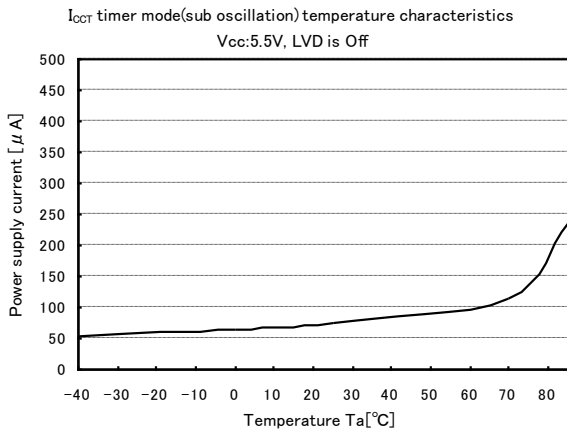

Power supply current (Stop mode)

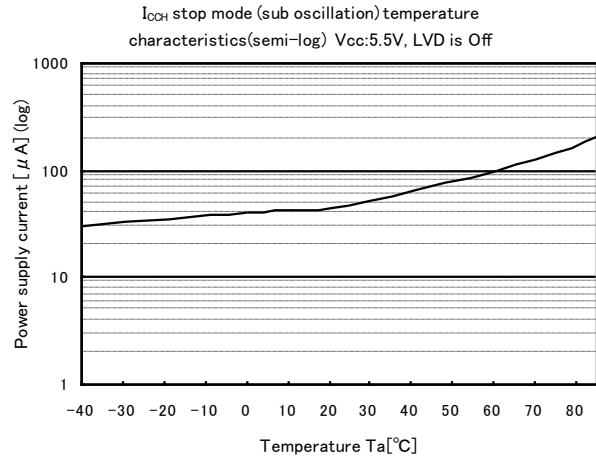
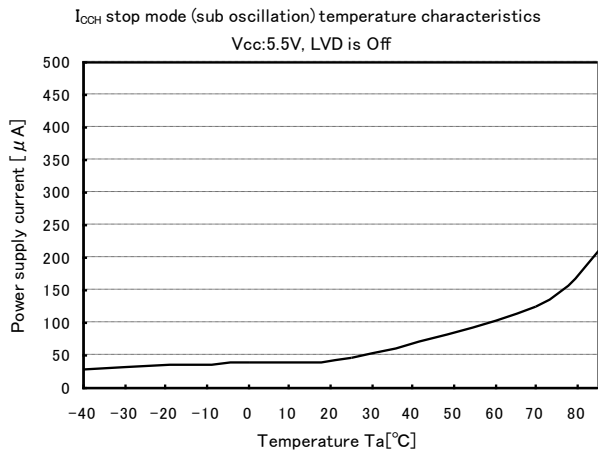

14. Ordering Information

| Part Number | On-chip Flash Memory | On-chip SRAM | Package | Packing |
|----------------------|----------------------|--------------|--|---------|
| CY9BF304NBPMC-G-JNE2 | 256 Kbyte | 32 KB | Plastic • LQFP(0.5 mm pitch), 100-pin (LQ1100) | Tray |
| CY9BF304NBPMC-G-UNE1 | | | | |
| CY9BF305NBPMC-G-JNE2 | 384 Kbyte | 48 KB | | |
| CY9BF306NBPMC-G-UNE1 | 512 Kbyte | 64 KB | | |
| CY9BF306NBPMC-G-UNE2 | | | | |
| CY9BF304RBPMC-G-JNE2 | 256 Kbyte | 32 KB | Plastic • LQFP(0.5 mm pitch), 120-pin (LQM120) | |
| CY9BF304RBPMC-G-UNE1 | | | | |
| CY9BF305RBPMC-G-JNE2 | 384 Kbyte | 48 KB | | |
| CY9BF306RBPMC-G-JNE2 | 512 Kbyte | 64 KB | | |
| CY9BF304NBBGL-GK6E1 | 256 Kbyte | 32 KB | Plastic • FBGA(0.8 mm pitch), 112-pin (LBC112) | |
| CY9BF305NBBGL-GK6E1 | 384 Kbyte | 48 KB | | |
| CY9BF306NBBGL-GK6E1 | 512 Kbyte | 64 KB | | |

15. Package Dimensions

| Package Type | Package Code |
|--------------|--------------|
| LQFP 100 | LQ1100 |

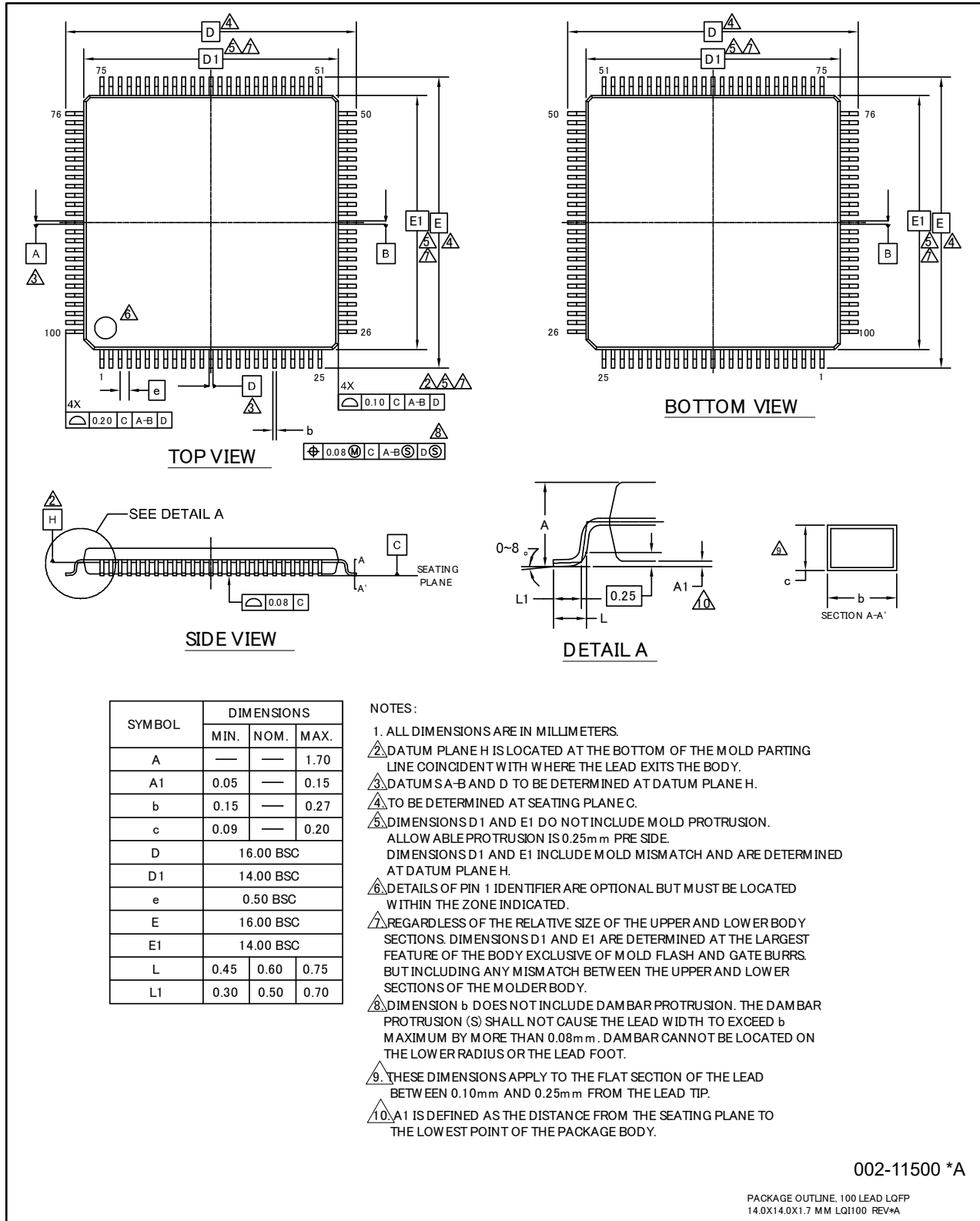

| | |
|---------------------|---------------------|
| Package Type | Package Code |
| LQFP 120 | LQM120 |

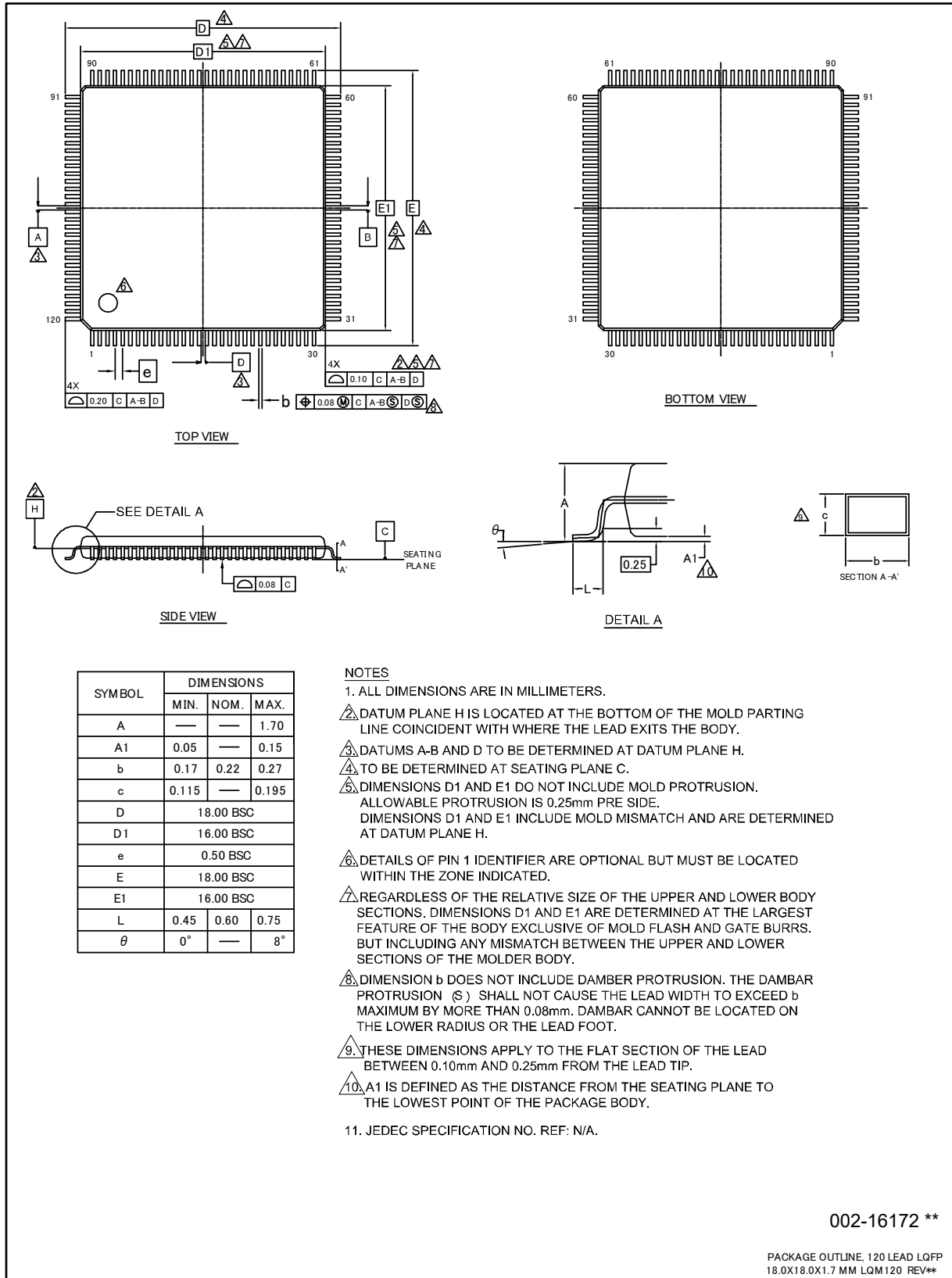

002-16172 **

PACKAGE OUTLINE, 120 LEAD LQFP
18.0X18.0X1.7 MM LQM120 REV**

| | |
|---------------------|---------------------|
| Package Type | Package Code |
| FBGA 112 | LBC112 |

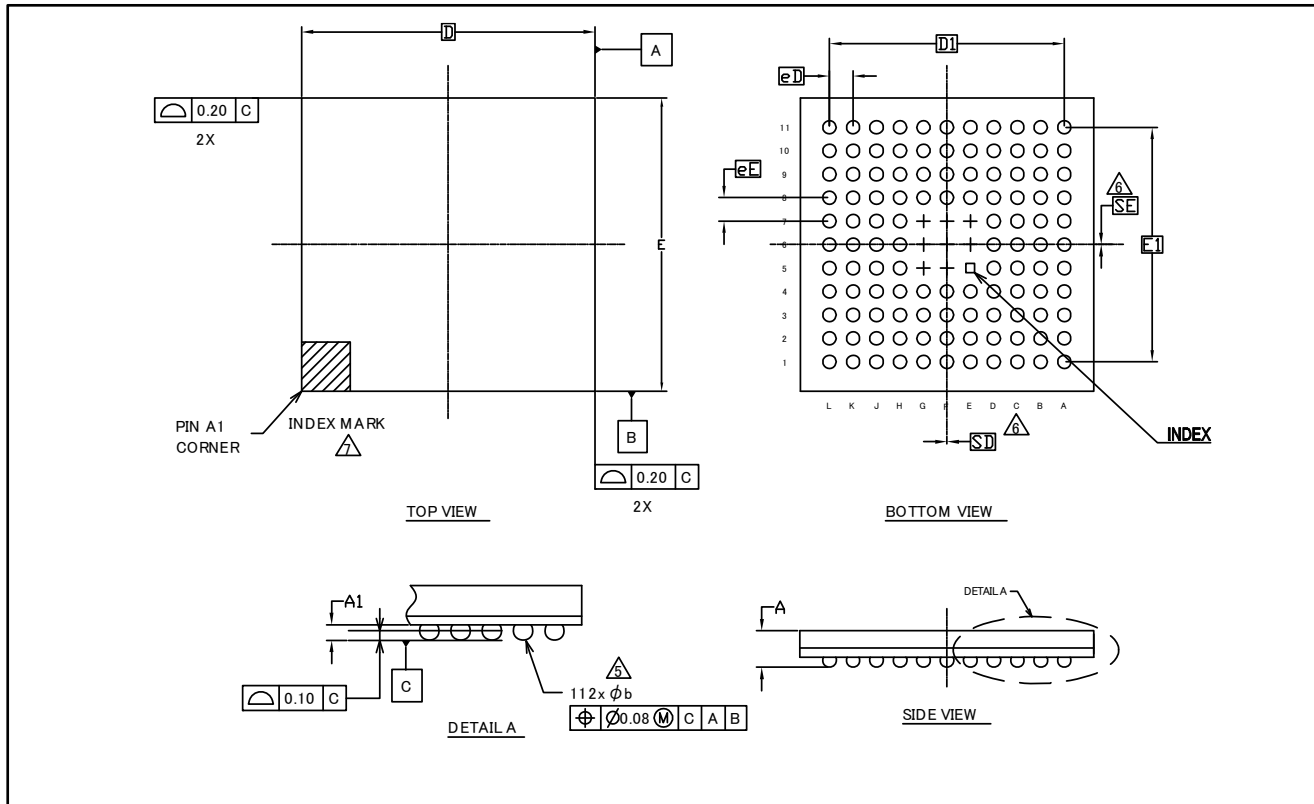

NOTES

- ALL DIMENSIONS ARE IN MILLIMETERS.
- SOLDER BALL POSITION DESIGNATION PER JEP95, SECTION 3, SPP-020.
- "e" REPRESENTS THE SOLDER BALL GRID PITCH.
- SYMBOL "MD" IS THE BALL MATRIX SIZE IN THE "D" DIRECTION. SYMBOL "ME" IS THE BALL MATRIX SIZE IN THE "E" DIRECTION. N IS THE NUMBER OF POPULATED SOLDER BALL POSITIONS FOR MATRIX SIZE M D X M E.
- DIMENSION "b" IS MEASURED AT THE MAXIMUM BALL DIAMETER IN A PLANE PARALLEL TO DATUM C.
- "SD" AND "SE" ARE MEASURED WITH RESPECT TO DATUMS A AND B AND DEFINE THE POSITION OF THE CENTER SOLDER BALL IN THE OUTER ROW. WHEN THERE IS AN ODD NUMBER OF SOLDER BALLS IN THE OUTER ROW, "SD" OR "SE" = 0. WHEN THERE IS AN EVEN NUMBER OF SOLDER BALLS IN THE OUTER ROW, "SD" = eD/2 AND "SE" = eE/2.
- A1 CORNER TO BE IDENTIFIED BY CHAMFER, LASER OR INK MARK METALIZED MARK, INDENTATION OR OTHER MEANS.
- "+" INDICATES THE THEORETICAL CENTER OF DEPOPULATED SOLDER BALLS.

| SYMBOL | DIMENSIONS | | |
|----------|------------|------|------|
| | MIN. | NOM. | MAX. |
| A | - | - | 1.45 |
| A1 | 0.25 | 0.35 | 0.45 |
| D | 10.00 BSC | | |
| E | 10.00 BSC | | |
| D1 | 8.00 BSC | | |
| E1 | 8.00 BSC | | |
| MD | 11 | | |
| ME | 11 | | |
| N | 112 | | |
| ϕb | 0.35 | 0.45 | 0.55 |
| eD | 0.80 BSC | | |
| eE | 0.80 BSC | | |
| SD | 0.00 | | |
| SE | 0.00 | | |

002-13225 **

PACKAGE OUTLINE, 112 BALL FBGA
10.00X10.00X1.45 MM LBC112 REV**

16. Errata

This chapter describes the errata for CY9B300R and CY9B300RA series. Details include errata trigger conditions, scope of impact, available workaround, and silicon revision applicability.

Contact your local Cypress Sales Representative if you have questions.

16.1 Part Numbers Affected

| Part Number |
|---|
| Initial Revision |
| CY9BF304RPMC-G-JNE2, CY9BF305RPMC-G-JNE2, CY9BF306RPMC-G-JNE2, CY9BF304NPMC-G-JNE2, CY9BF305NPMC-G-JNE2, CY9BF306NPMC-G-JNE2, CY9BF304NBGL-GE1, CY9BF305NBGL-GE1, CY9BF306NBGL-GE1, CY9BF306NBGL-GK6E1 |
| Rev. A |
| CY9BF304RAPMC-G-JNE2, CY9BF305RAPMC-G-JNE2, CY9BF306RAPMC-G-JNE2, CY9BF304NAPMC-G-JNE2, CY9BF305NAPMC-G-JNE2, CY9BF306NAPMC-G-JNE2, CY9BF304NABGL-GE1, CY9BF305NABGL-GE1, CY9BF306NABGL-GE1 |

16.2 Qualification Status

Product Status: In Production – Qual.

16.3 Errata Summary

This table defines the errata applicability to available devices.

| Items | Part Number | Silicon Revision | Fix Status |
|---|---------------|-----------------------------|-----------------|
| [1] Timer/Stop Mode Issue | Refer to 16.1 | Rev. initial rev. | Fixed in Rev. A |
| [2] USB HOST Issue | Refer to 16.1 | Rev. initial rev. Rev. A | Fixed in Rev. B |
| [3] Gap Between Watch Counter Value and Real Time at Return in Timer Mode | Refer to 16.1 | Rev. initial rev. | Fixed in Rev. A |

16.4 Errata Detail

16.4.1 Timer and Stop Mode Issue

■ PROBLEM DEFINITION

MCU does not return from timer or stop mode.

■ PARAMETERS AFFECTED

N/A

■ TRIGGER CONDITION(S)

The condition is that the timing of entering timer or stop mode and an interruption occurrence meet.

■ SCOPE OF IMPACT

MCU does not return from time or stop mode.

■ WORKAROUND

This error cannot be avoided by any software, except not using timer and stop mode.

■ FIX STATUS

This issue was fixed in Rev. A.

16.4.2 USB HOST Issue
■ PROBLEM DEFINITION

Unexpected USB transfer is generated or USB HOST stops its operation.

■ PARAMETERS AFFECTED

N/A

■ TRIGGER CONDITION(S)

The condition is that all (1) and (2) and (3) and (4) meet.

- (1) The timing of rising edge of USB clock and the timing of rising edge of CPU clock meet
- (2) Endpoint processing is on-going
- (3) USB bus is differential 1
- (4) One of these cases happens
 - Case 1: TKNEN bits are set to 001 from 110.
 - Case 2: TKNEN is set to 111.

■ SCOPE OF IMPACT

USB HOST does not work properly.

■ WORKAROUND

This error cannot be avoided by any software, except not using USB HOST.

■ FIX STATUS

This issue was fixed in Rev. B.

16.4.3 Gap Between Watch Counter Value and Real Time at Return in Timer Mode
■ PROBLEM DEFINITION

There is a gap between the value of the counter and the real time at the return by the interrupt in the sub-timer mode or the low speed CR timer mode. When the watch counter using the sub-crystal oscillator is used in the sub timer mode or the low speed CR timer mode, the value of the watch counter has a “Low speed CR x 35clock” delay (about 350us at waiting for the stability of the regulator) at the return by the interrupt. As a result, a gap occurs between the value of the counter and the real time.

The following figure shows the timing waveform.

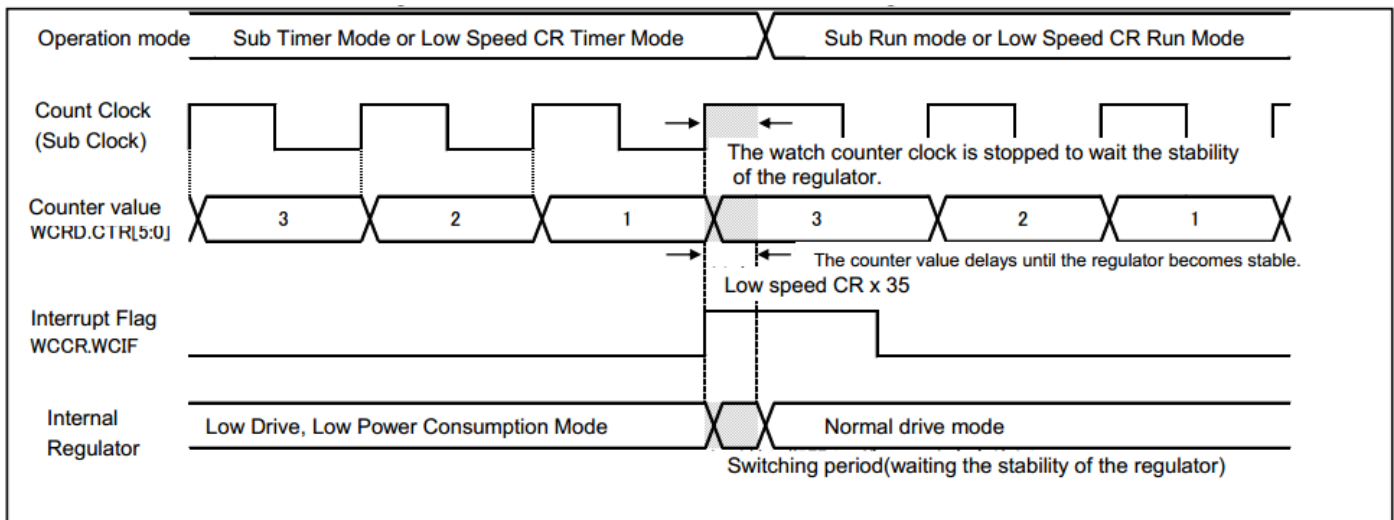
■ ROOT CAUSE

The internal regulator operates with low drive and low power consumption in the sub timer mode or the low speed CR timer mode. When the interrupt is requested, the mode of the internal regulator is switched to the normal drive mode. At this time, a switching time for the stability of the regulator is required.

This MCU is designed for keeping down the voltage variation of the regulator by reducing the current. To achieve it, the clock to the watch counter is stopped in the period.

At a result, the value of the watch counter delay until the time for the stability of the regulator is shown in the Figure. Therefore, a gap occurs between the value of the counter and the real time.

■ TRIGGER CONDITION(S)

When both of (1) and (2) described in below is applicable, the gap occurs.

(1) CPU Operation Mode

The gap occurs in the sub timer mode or the low speed CR mode.

It does not occur in the following modes:

- Run modes (PLL, main, high speed CR, sub, and low speed CR)
- Sleep modes (PLL, main, high speed CR, sub, low speed CR)
- PLL timer mode
- Main timer mode
- High speed CR timer mode
- Stop mode

(2) Return Factor

The gap occurs when any of the following interrupt is requested for the return in the sub timer mode or the low speed CR timer mode.

- NMI interrupt
- External interrupt
- Hardware Watchdog Timer interrupt
- USB Wakeup interrupt
- Watch Counter interrupt
- Low-voltage detection interrupt
- The gap does not occur in the standby return by the reset because the value of the counter is cleared

■ WORKAROUND

When the extremely accuracy is required for the count time of the watch counter, use the sub sleep mode or the low speed CR sleep mode.

■ FIX STATUS

This issue was fixed in Rev. A.

17. Major Changes

Spanion Publication Number: DS706-00024

| Page | Section | Change Results |
|--------------|--|---|
| Revision 1.0 | | |
| - | - | Initial release |
| Revision 2.0 | | |
| - | - | Corrected series name and part number: MB9B300A Series → MB9B300B Series, MB9BF304NA → MB9BF304NB, MB9BF304RA → MB9BF304RB, MB9BF305NA → MB9BF305NB, MB9BF305RA → MB9BF305RB, MB9BF306NA → MB9BF306NB, MB9BF306RA → MB9BF306RB |
| Revision 2.1 | | |
| - | - | Company name and layout design change |
| Revision 3.0 | | |
| 2 | FEATURES USB Interface | Added the description of PLL for USB |
| 3 | FEATURES External Bus Interface | Added the description of Maximum area size |
| 8 | PACKAGES | Deleted the description of ES |
| 17 | LIST OF PIN FUNCTIONS List of pin numbers | Modified the Pin state type of P4E from I to H |
| 32-35 | LIST OF PIN FUNCTIONS List of pin functions | Added LIN to the description of SOTxx |
| 42 | I/O CIRCUIT TYPE | Added the description of I ² C to the type of E and F |
| 42, 43 | I/O CIRCUIT TYPE | Added about +B input |
| 48 | HANDLING DEVICES | Added "Stabilizing power supply voltage" |
| 48 | HANDLING DEVICES Crystal oscillator circuit | Added the following description "Evaluate oscillation of your using crystal oscillator by your mount board." |
| 49 | HANDLING DEVICES C Pin | Changed the description |
| 50 | BLOCK DIAGRAM | Modified the block diagram |
| 50 | MEMORY SIZE | Changed to the following description See "Memory size" in "PRODUCT LINEUP" to confirm the memory size. |
| 51 | MEMORY MAP Memory map(1) | Modified the area of "External Device Area" |
| 52 | MEMORY MAP Memory map(2) | Added the summary of Flash memory sector and the note |
| 59, 60 | ELECTRICAL CHARACTERISTICS 1. Absolute Maximum Ratings | Added the Clamp maximum current Added the output current of P80 and P81 Added about +B input |
| 61 | ELECTRICAL CHARACTERISTICS 2. Recommended Operation Conditions | Modified the minimum value of Analog reference voltage Added Smoothing capacitor Added the note about less than the minimum power supply voltage |
| 62, 63 | ELECTRICAL CHARACTERISTICS 3. DC Characteristics (1) Current rating | Changed the table format Added Main TIMER mode current Added Flash Memory Current Moved A/D Converter Current |
| 65 | ELECTRICAL CHARACTERISTICS 4. AC Characteristics (1) Main Clock Input Characteristics | Added Master clock at Internal operating clock frequency |
| 66 | ELECTRICAL CHARACTERISTICS 4. AC Characteristics (3) Built-in CR Oscillation Characteristics | Added Frequency stability time at Built-in high-speed CR |

| Page | Section | Change Results |
|--------|---|--|
| 67 | ELECTRICAL CHARACTERISTICS 4. AC Characteristics (4-1) Operating Conditions of Main and USB PLL (4-2) Operating Conditions of Main PLL | Added Main PLL clock frequency Added USB clock frequency Added the figure of Main PLL connection and USB PLL connection |
| 68 | ELECTRICAL CHARACTERISTICS 4. AC Characteristics (6) Power-on Reset Timing | Added Time until releasing Power-on reset Changed the figure of timing |
| 74-81 | ELECTRICAL CHARACTERISTICS 4. AC Characteristics (7) CSIO/UART Timing | Modified from UART Timing to CSIO/UART Timing Changed from Internal shift clock operation to Master mode Changed from External shift clock operation to Slave mode |
| 88 | ELECTRICAL CHARACTERISTICS 5. 12bit A/D Converter | Added the typical value of Integral Nonlinearity, Differential Nonlinearity, Zero transition voltage and Full-scale transition voltage Added Conversion time at AVcc < 4.5 V Modified Stage transition time to operation permission Modified the minimum value of Reference voltage |
| 91 | ELECTRICAL CHARACTERISTICS 6. USB Characteristics | Modified condition of Output Low level voltage |
| 96 | ELECTRICAL CHARACTERISTICS 8. Flash Memory Write/Erase Characteristics | Change to the erase time of include write time prior to internal erase |
| 97-100 | ELECTRICAL CHARACTERISTICS 9. Return Time from Low-Power Consumption Mode | Added Return Time from Low-Power Consumption Mode |
| 103 | ORDERING INFORMATION | Change to full part number |
| 104 | PACKAGE DIMENSIONS | Deleted FPT-100P-M20 and FPT-120P-M21 |

Note: Please see “Document History” about later revised information.

Document History

Document Title: CY9B300B Series 32-bit Arm® Cortex®-M3 FM3 Microcontroller

Document Number: 002-05612

| Revision | ECN | Orig. of Change | Submission Date | Description of Change | | | | | | | | |
|--------------|---------|-----------------|-----------------|---|--------|-------|--------------|--------|--------------|--------|--------------|--------|
| ** | – | AKIH | 12/15/2014 | Migrated to Cypress and assigned document number 002-05612. No change to document contents. | | | | | | | | |
| *A | 5206321 | AKIH | 04/11/2016 | Updated to Cypress template. | | | | | | | | |
| *B | 5486354 | HTER | 03/02/2017 | <p>Updated Cypress Logo.</p> <p>Corrected the following statement USB Function → USB Device in chapter: Features (Page 1) 1. Product Lineup (Page 6) 4. List of Pin Functions (Page 36) 8. Block Diagram (Page 47).</p> <p>Corrected the following statement J-TAG → JTAG in chapter 4. List of Pin Functions (Page 25)</p> <p>Added “Note” about TAP pins in chapter 4. List of Pin Functions (Page 37).</p> <p>Added the Baud rate spec in 12.4.10 CSIO Timing (Page 72-78)</p> <p>Corrected the following statement Analog port input current → Analog port input leak current in chapter 12.5 12-bit A/D Converter (Page 86).</p> <p>Corrected the following statement Comrare clock cycle → Compare clock cycle in chapter 12.5 12-bit A/D Converter (Page 87).</p> <p>Changed the package codes as the following table in chapter: 2. Packages (Page 7) 3. Pin Assignment (Page 8-10) 12.2 Recommended Operating Conditions (Page 57) 14. Ordering Information (Page 101) 15. Package Dimensions (Page 102-104).</p> <table border="1"> <thead> <tr> <th>Before</th> <th>After</th> </tr> </thead> <tbody> <tr> <td>FPT-100P-M23</td> <td>LQI100</td> </tr> <tr> <td>FPT-120P-M37</td> <td>LQM120</td> </tr> <tr> <td>BGA-112P-M04</td> <td>LBC112</td> </tr> </tbody> </table> <p>Added the Part numbers - MB9BF304RBPMC-G-UNE1 in chapter 14. Ordering Information (Page 101).</p> <p>Corrected the Part numbers - MB9BF304NBBGL-G-YE1 → MB9BF304NBBGL-GK6E1 - MB9BF305NBBGL-G-YE1 → MB9BF305NBBGL-GK6E1 - MB9BF306NBBGL-G-YE1 → MB9BF306NBBGL-GK6E1 in chapter 14. Ordering Information (Page 101).</p> <p>Added 16. Errata (Page 105-106)</p> | Before | After | FPT-100P-M23 | LQI100 | FPT-120P-M37 | LQM120 | BGA-112P-M04 | LBC112 |
| Before | After | | | | | | | | | | | |
| FPT-100P-M23 | LQI100 | | | | | | | | | | | |
| FPT-120P-M37 | LQM120 | | | | | | | | | | | |
| BGA-112P-M04 | LBC112 | | | | | | | | | | | |

| Revision | ECN | Orig. of Change | Submission Date | Description of Change |
|----------|---------|-----------------|-----------------|---|
| *C | 5811601 | YSAT | 07/13/2017 | Updated Cypress Logo and Copyright. |
| *D | 5942095 | HUAL | 10/24/2017 | <p>Corrected the following Clock frequency MAX value (When not trimming) 5 MHz → 6 MHz in chapter 12.4.3 Built-in CR Oscillation Characteristics.</p> <p>Added the Part numbers in chapter 14. Ordering Information.</p> <ul style="list-style-type: none"> - MB9BF304NBPMC-G-UNE1 - MB9BF306NBPMC-G-UNE1 <p>Corrected the Part numbers in chapter 14. Ordering Information.</p> <ul style="list-style-type: none"> - MB9BF306NBPMC-G-JNE2 → MB9BF306NBPMC-G-UNE2 <p>Added the errata 002-06782 contents in chapter 16. Errata.</p> <p>Completing Sunset Review.</p> |
| *E | 6575967 | HUAL | 05/17/2019 | <p>Updated Document Title to read as “CY9B300B Series 32-bit Arm® Cortex®-M3 FM3 Microcontroller”.</p> <p>Replaced “MB9B300B Series” with “CY9B300B Series” in all instances across the document.</p> <p>Updated Ordering Information:</p> <p>Updated part numbers.</p> <p>Updated to new template.</p> |

Sales, Solutions, and Legal Information

Worldwide Sales and Design Support

Cypress maintains a worldwide network of offices, solution centers, manufacturer's representatives, and distributors. To find the office closest to you, visit us at [Cypress Locations](#).

Products

| | |
|-------------------------------|--|
| Arm® Cortex® Microcontrollers | cypress.com/arm |
| Automotive | cypress.com/automotive |
| Clocks & Buffers | cypress.com/clocks |
| Interface | cypress.com/interface |
| Internet of Things | cypress.com/iot |
| Memory | cypress.com/memory |
| Microcontrollers | cypress.com/mcu |
| PSoC | cypress.com/psoc |
| Power Management ICs | cypress.com/pmic |
| Touch Sensing | cypress.com/touch |
| USB Controllers | cypress.com/usb |
| Wireless Connectivity | cypress.com/wireless |

PSoC® Solutions

[PSoC 1](#) | [PSoC 3](#) | [PSoC 4](#) | [PSoC 5LP](#) | [PSoC 6 MCU](#)

Cypress Developer Community

[Community](#) | [Projects](#) | [Videos](#) | [Blogs](#) | [Training](#) | [Components](#)

Technical Support

cypress.com/support

Arm and Cortex are registered trademarks of Arm Limited (or its subsidiaries) in the US and/or elsewhere. All other trademarks or registered trademarks referenced herein are the property of their respective owners.



© Cypress Semiconductor Corporation, 2011-2019. This document is the property of Cypress Semiconductor Corporation and its subsidiaries ("Cypress"). This document, including any software or firmware included or referenced in this document ("Software"), is owned by Cypress under the intellectual property laws and treaties of the United States and other countries worldwide. Cypress reserves all rights under such laws and treaties and does not, except as specifically stated in this paragraph, grant any license under its patents, copyrights, trademarks, or other intellectual property rights. If the Software is not accompanied by a license agreement and you do not otherwise have a written agreement with Cypress governing the use of the Software, then Cypress hereby grants you a personal, non-exclusive, nontransferable license (without the right to sublicense) (1) under its copyright rights in the Software (a) for Software provided in source code form, to modify and reproduce the Software solely for use with Cypress hardware products, only internally within your organization, and (b) to distribute the Software in binary code form externally to end users (either directly or indirectly through resellers and distributors), solely for use on Cypress hardware product units, and (2) under those claims of Cypress's patents that are infringed by the Software (as provided by Cypress, unmodified) to make, use, distribute, and import the Software solely for use with Cypress hardware products. Any other use, reproduction, modification, translation, or compilation of the Software is prohibited.

TO THE EXTENT PERMITTED BY APPLICABLE LAW, CYPRESS MAKES NO WARRANTY OF ANY KIND, EXPRESS OR IMPLIED, WITH REGARD TO THIS DOCUMENT OR ANY SOFTWARE OR ACCOMPANYING HARDWARE, INCLUDING, BUT NOT LIMITED TO, THE IMPLIED WARRANTIES OF MERCHANTABILITY AND FITNESS FOR A PARTICULAR PURPOSE. No computing device can be absolutely secure. Therefore, despite security measures implemented in Cypress hardware or software products, Cypress shall have no liability arising out of any security breach, such as unauthorized access to or use of a Cypress product. CYPRESS DOES NOT REPRESENT, WARRANT, OR GUARANTEE THAT CYPRESS PRODUCTS, OR SYSTEMS CREATED USING CYPRESS PRODUCTS, WILL BE FREE FROM CORRUPTION, ATTACK, VIRUSES, INTERFERENCE, HACKING, DATA LOSS OR THEFT, OR OTHER SECURITY INTRUSION (collectively, "Security Breach"). Cypress disclaims any liability relating to any Security Breach, and you shall and hereby do release Cypress from any claim, damage, or other liability arising from any Security Breach. In addition, the products described in these materials may contain design defects or errors known as errata which may cause the product to deviate from published specifications. To the extent permitted by applicable law, Cypress reserves the right to make changes to this document without further notice. Cypress does not assume any liability arising out of the application or use of any product or circuit described in this document. Any information provided in this document, including any sample design information or programming code, is provided only for reference purposes. It is the responsibility of the user of this document to properly design, program, and test the functionality and safety of any application made of this information and any resulting product. "High-Risk Device" means any device or system whose failure could cause personal injury, death, or property damage. Examples of High-Risk Devices are weapons, nuclear installations, surgical implants, and other medical devices. "Critical Component" means any component of a High-Risk Device whose failure to perform can be reasonably expected to cause, directly or indirectly, the failure of the High-Risk Device, or to affect its safety or effectiveness. Cypress is not liable, in whole or in part, and you shall and hereby do release Cypress from any claim, damage, or other liability arising from any use of a Cypress product as a Critical Component in a High-Risk Device. You shall indemnify and hold Cypress, its directors, officers, employees, agents, affiliates, distributors, and assigns harmless from and against all claims, costs, damages, and expenses, arising out of any claim, including claims for product liability, personal injury or death, or property damage arising from any use of a Cypress product as a Critical Component in a High-Risk Device. Cypress products are not intended or authorized for use as a Critical Component in any High-Risk Device except to the limited extent that (i) Cypress's published data sheet for the product explicitly states Cypress has qualified the product for use in a specific High-Risk Device, or (ii) Cypress has given you advance written authorization to use the product as a Critical Component in the specific High-Risk Device and you have signed a separate indemnification agreement.

Cypress, the Cypress logo, Spansion, the Spansion logo, and combinations thereof, WICED, PSoC, CapSense, EZ-USB, F-RAM, and Traveo are trademarks or registered trademarks of Cypress in the United States and other countries. For a more complete list of Cypress trademarks, visit cypress.com. Other names and brands may be claimed as property of their respective owners.

Looking for pricing, stock, or lifecycle information?

Click below to explore more details on WIN SOURCE:

-  [View CY9BF306NBPMC-G-UNE1 on WIN SOURCE](#)
-  [Infineon Technologies](#) Information

Optimize Your Supply Chain with WIN SOURCE Solutions

-  Global Sourcing Solution
-  Obsolete Management
-  Cost Control Management
-  Shortage Management
-  Alternative Solution
-  Excess Inventory Management