

Fiber Optic Receiver

OPF520 Series



Features:

- Low Cost plastic cap package
- Designed to self align in the bore of standard fiber optic receptacles
- Press fit simplifies installation
- Optimized for fiber optic applications using 50 to 200 micron fiber
- 5 Mb/s

Description:

The OPF520 series fiber optic receiver is a high performance device packaged for data communications links. As such, it is designed to work with fiber core diameters from 50 μm to 200 μm and over a broad input power range. The construction contains a monolithic photo-IC comprised of a photodiode, biasing network, DC amplifier and an open collector output transistor. The output circuitry makes this device compatible with TTL and CMOS logic.

This receiver is designed to operate from a single 5 V supply. It is essential that a bypass capacitor be connected from V_{CC} to GND in order to ensure the best possible operation.

Applications:

- Industrial Ethernet equipment
- Copper-to-fiber media conversion
- Intra-system fiber optic links
- Video surveillance systems

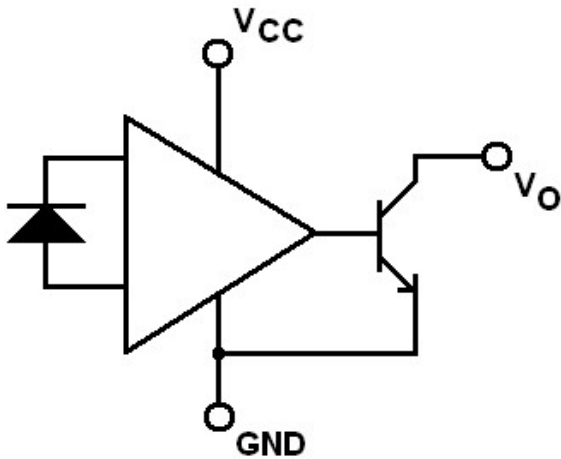

Part Ordering Information	
Part Number	Description
OPF520	Plastic Cap Component
OPF522	Metal ST Receptacle (Standard screw)
OPF522-1	Metal ST Receptacle (Phillips screw)

Recommended Test Circuit

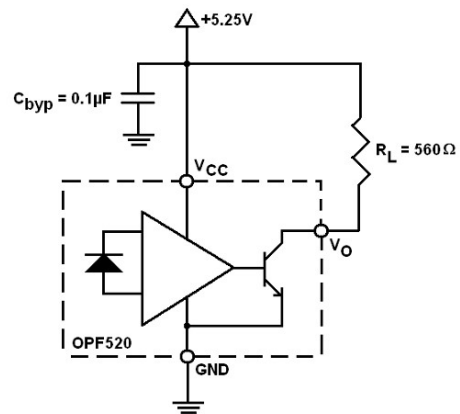

General Note

TT Electronics reserves the right to make changes in product specification without notice or liability. All information is subject to TT Electronics' own data and is considered accurate at time of going to print.

Mechanical Outline—OPF520

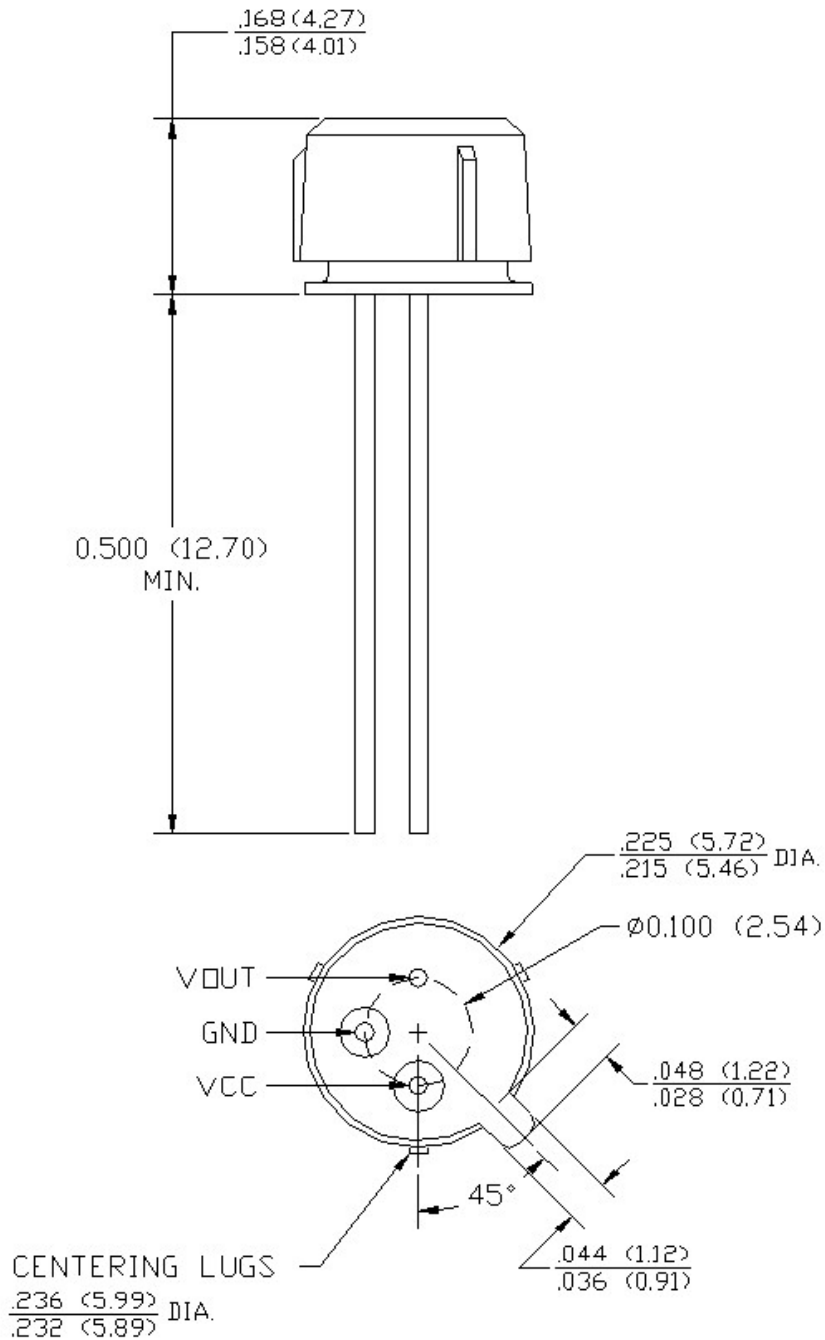

General Note
TT Electronics reserves the right to make changes in product specification without notice or liability. All information is subject to TT Electronics' own data and is considered accurate at time of going to print.

TT Electronics | OPTEK Technology
2900 E. Plano Pkwy, Plano, TX 75074 | Ph: +1 972 323 2200
www.ttelectronics.com | sensors@ttelectronics.com

Mechanical Outline—OPF522

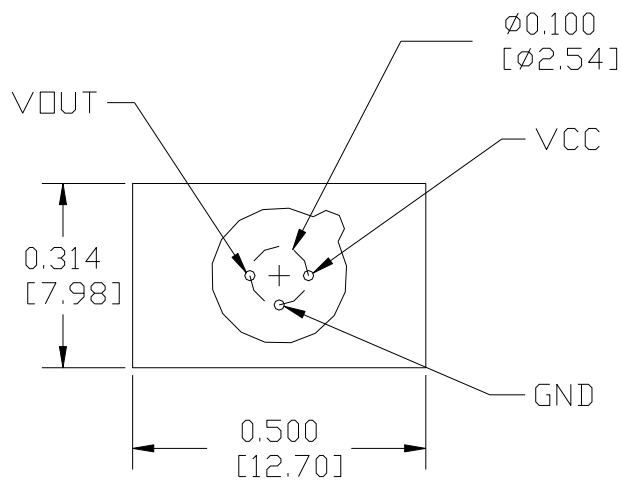
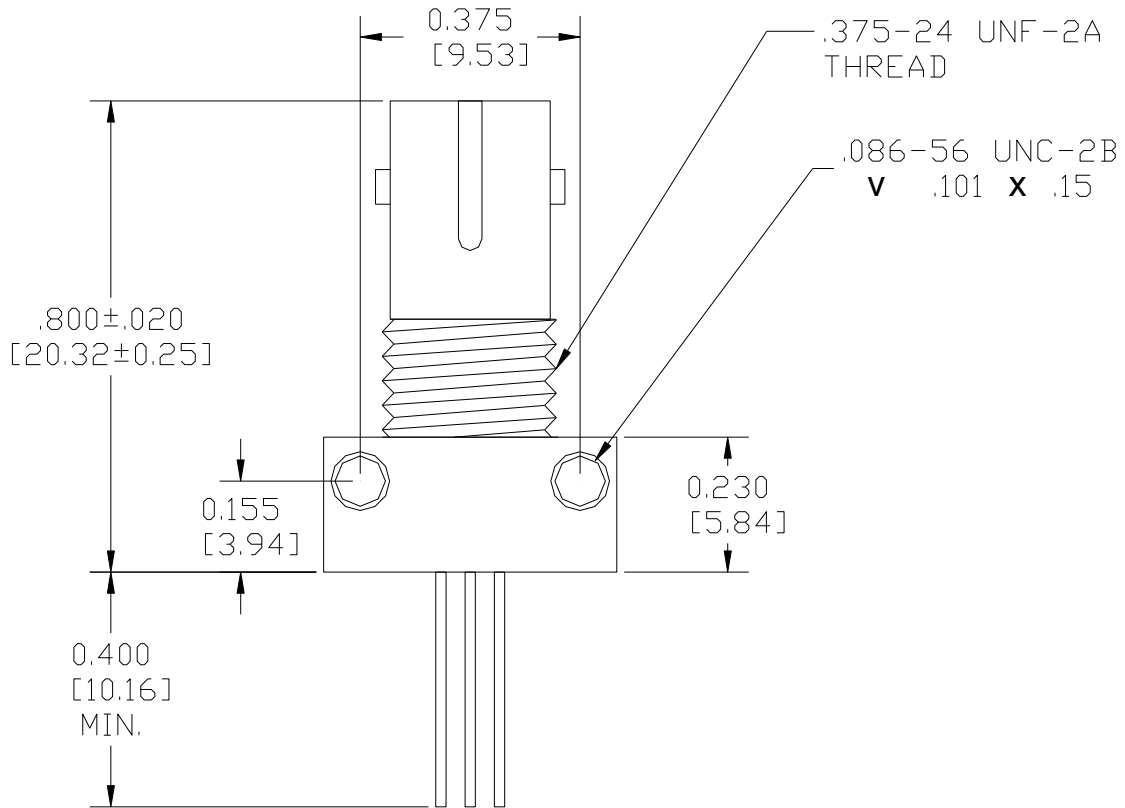

General Note

TT Electronics reserves the right to make changes in product specification without notice or liability. All information is subject to TT Electronics' own data and is considered accurate at time of going to print.

TT Electronics | OPTEK Technology
2900 E. Plano Pkwy, Plano, TX 75074 | Ph: +1 972 323 2200
www.ttelectronics.com | sensors@ttelectronics.com

Electrical Specifications

Absolute Maximum Ratings ($T_A = 25^\circ\text{C}$ unless otherwise noted)

Storage Temperature	55° C to +115° C
Operating Temperature	-40° C to +85° C
Lead Soldering Temperature (for 10 seconds)	260° C
Supply Voltage	-0.5 V to +7.0 V
Output Current	25 mA
Output Voltage	-0.5 V to +18.0 V
Open Collector Power Distribution	40mW
Fan Out (TTL)	5 ⁽¹⁾

Electrical Characteristics ($T_A = 25^\circ\text{C}$ unless otherwise noted)

SYM-BOL	PARAMETER	MIN	TYP	MAX	UNITS	TEST CONDITIONS
I_{OH}	High Level Output Current		5	250	μA	$V_O = 18\text{V}$, $P_{OC} < -40\text{ dBm}$, See Note 2
V_{OL}	Low Level Output Voltage		0.2	0.5	V	$I_O = 8\text{ mA}$, $P_{OC} > -24\text{ dBm}$, See Note 2
I_{CCH}	Supply Current, Output High		3.5	6.3	mA	$V_{CC} = 5.25\text{ V}$, $P_{OC} < -40\text{ dBm}$, See Note 2
I_{CCL}	Supply Current, Output Low		6.9	10	mA	$V_{CC} = 5.25\text{ V}$, $P_{OC} < -24\text{ dBm}$, See Note 2
$P_{OC(H)}$	Peak Input Power Level, Output High			-40	dBm	$\lambda_p = 850\text{ nm}$
	(Guaranteed Output High)			0.1	μW	
$P_{OC(L)}$	Peak Input Power Level, Output Low	-25.4		-9.2	dBm	$\lambda_p = 850\text{ nm}$, $I_O = 8\text{ mA}$
		2.9		120	μW	
	(Guaranteed Output Low)	-24		-10	dBm	$\lambda_p = 850\text{ nm}$, $I_O = 8\text{ mA}$
		4.0		100	μW	$-40^\circ\text{C} \leq T_A \leq +85^\circ\text{C}$
t_r, t_f	Rise, Fall Time		30		ns	$P_{OC} = -20\text{ dBm (peak)}$, $f = 2.5\text{ MHz}$, See Note 3
t_{PDHL}	Propagation Delay, Output High to Low		65		ns	
t_{PDLH}	Propagation Delay, Output Low to High		100		ns	
PWD	Pulse Width Distortion		± 30		%	

Notes:

- 8 mA load ($5 \times 1.6\text{ mA}$), $R_L = 560\ \Omega$
- Use recommended test circuit below, but connect V_O to an independent voltage source with $R_L = 0$.
- Use recommended test circuit below.

General Note

TT Electronics reserves the right to make changes in product specification without notice or liability. All information is subject to TT Electronics' own data and is considered accurate at time of going to print.

Performance

Switching Characteristics

(See Recommended Test Circuit)

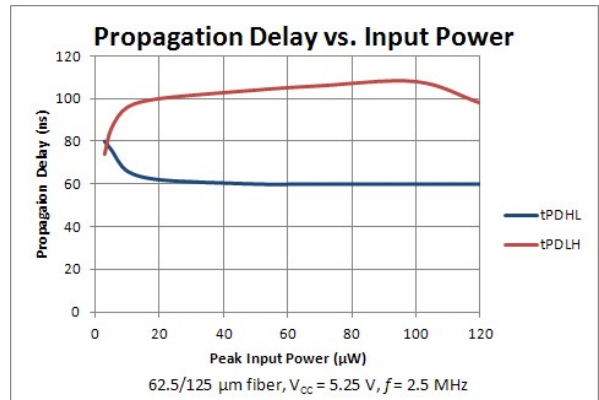
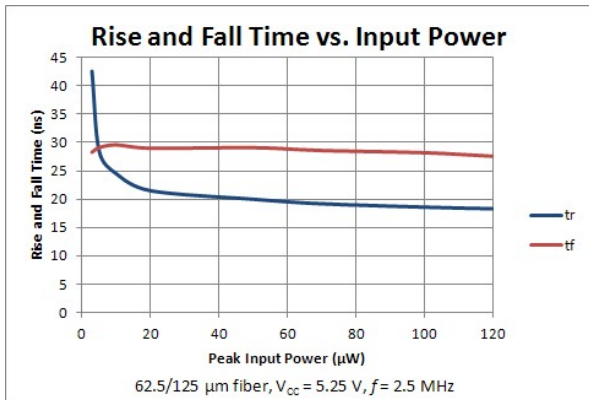
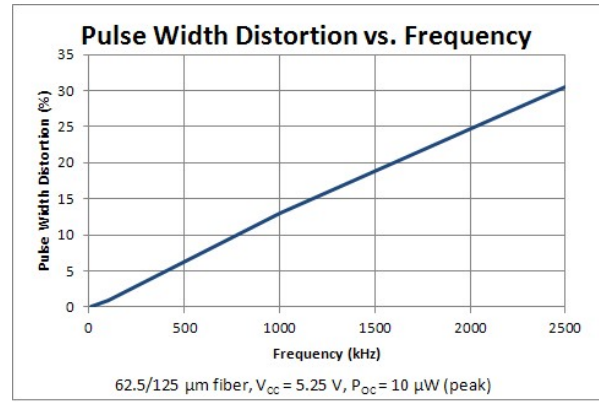
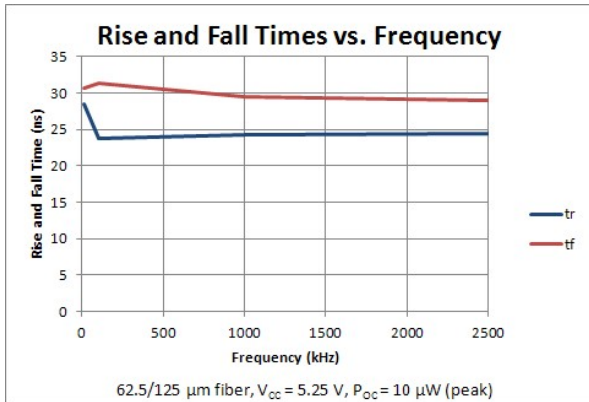
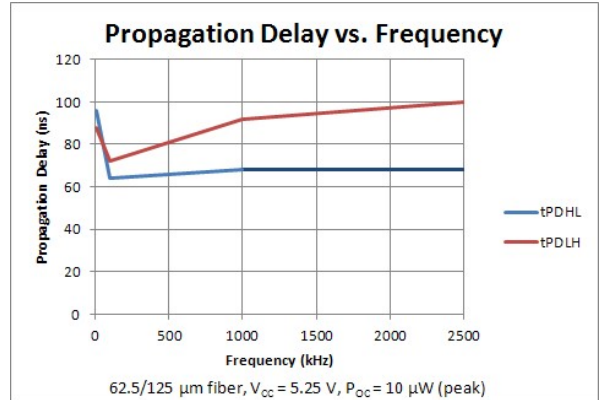
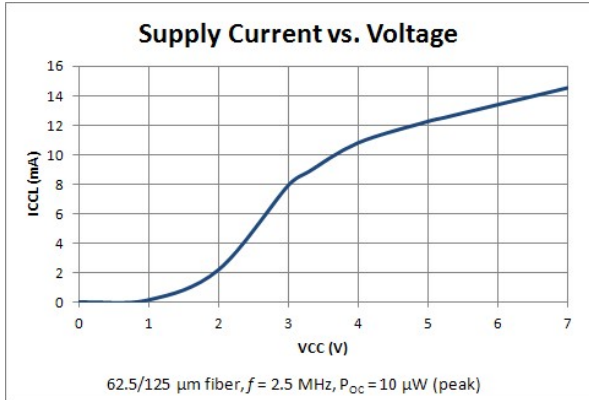

General Note

TT Electronics reserves the right to make changes in product specification without notice or liability. All information is subject to TT Electronics' own data and is considered accurate at time of going to print.

Performance

Switching Characteristics

(continued)

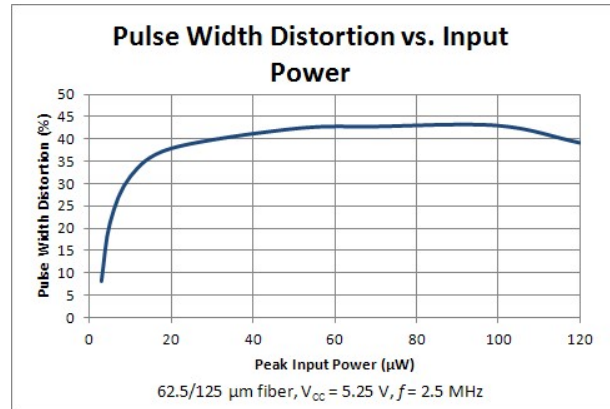
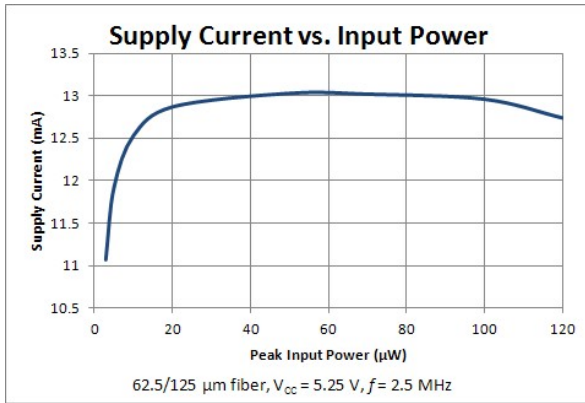

General Note

TT Electronics reserves the right to make changes in product specification without notice or liability. All information is subject to TT Electronics' own data and is considered accurate at time of going to print.

Performance

Typical Waveforms for Various Input Powers

(62.5/125 μm fiber, $V_{CC} = 5.25\text{ V}$, $f = 2.5\text{ MHz}$)
(See Recommended Test Circuit)

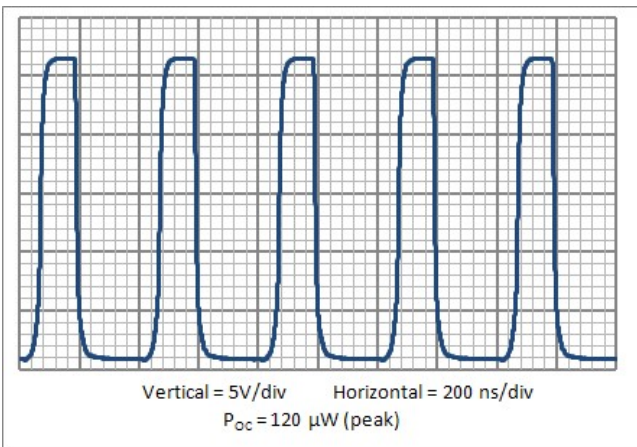
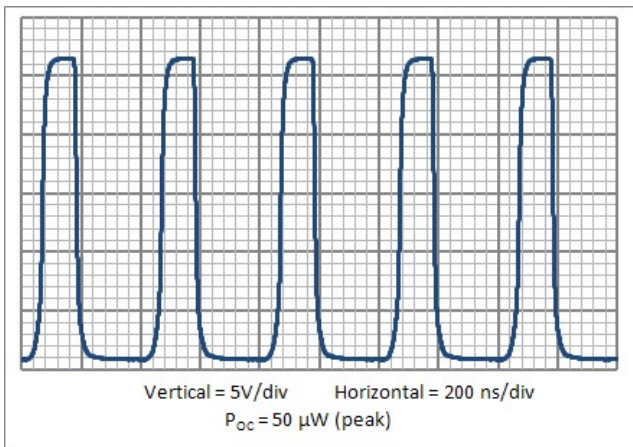
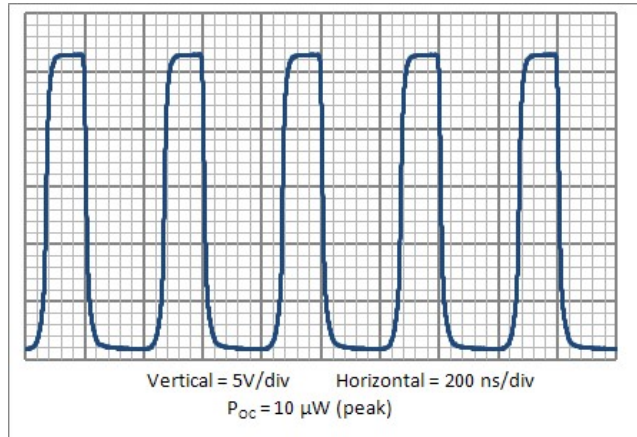
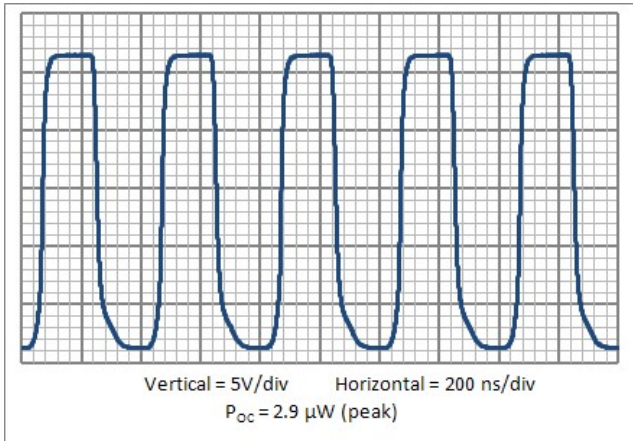

General Note

TT Electronics reserves the right to make changes in product specification without notice or liability. All information is subject to TT Electronics' own data and is considered accurate at time of going to print.

Performance

Typical Waveforms for Various Frequencies

(62.5/125 μm fiber, $V_{CC} = 5.25\text{ V}$, $P_{OC} = 10\mu\text{W}$ (peak)
(See Recommended Test Circuit)

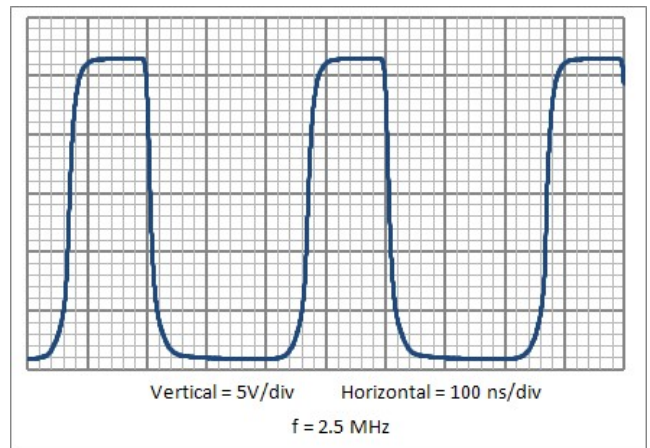
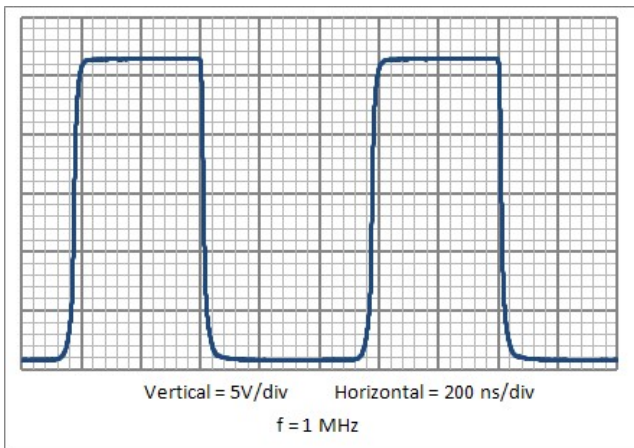
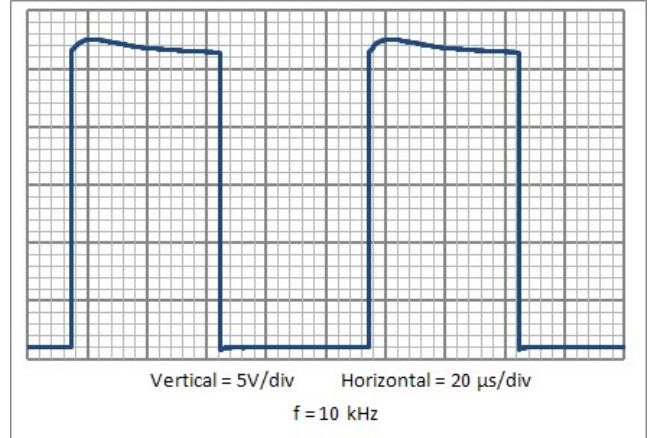
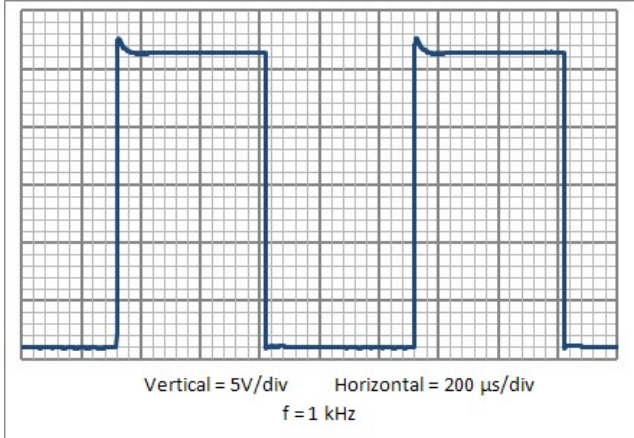

General Note

TT Electronics reserves the right to make changes in product specification without notice or liability. All information is subject to TT Electronics' own data and is considered accurate at time of going to print.

Performance

Typical Waveforms for Various Fiber Cables and Input Powers

($V_{CC} = 5.25\text{ V}$, $f = 2.5\text{ MHz}$)
(See Recommended Test Circuit)

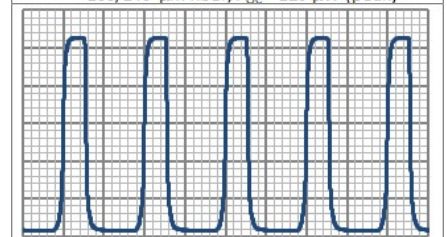
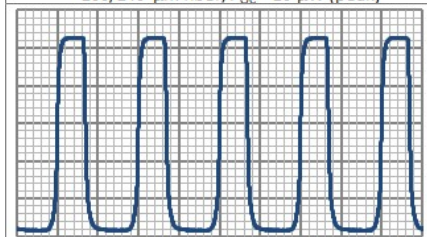
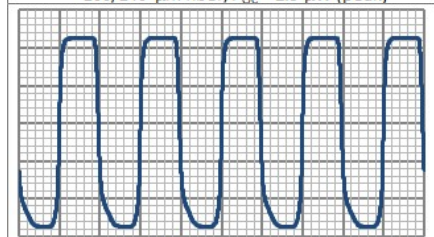
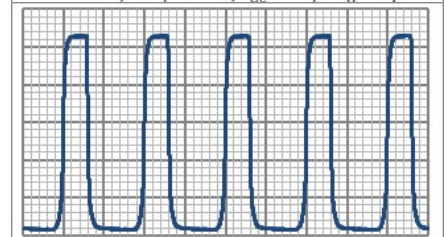
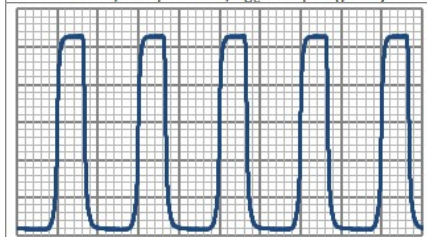
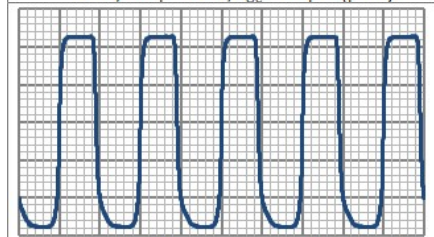
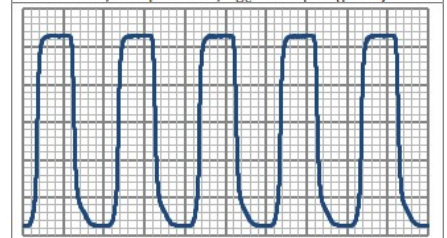
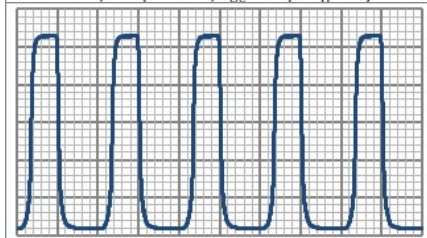
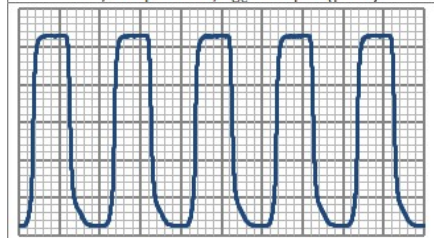
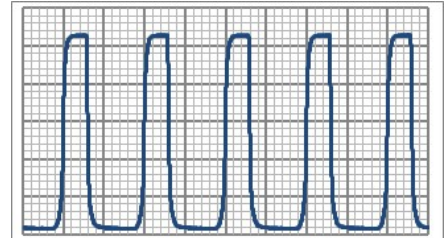
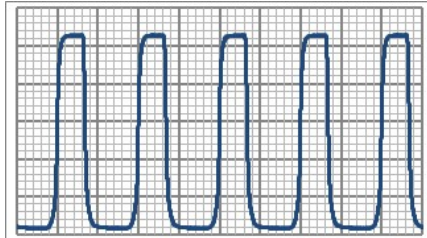
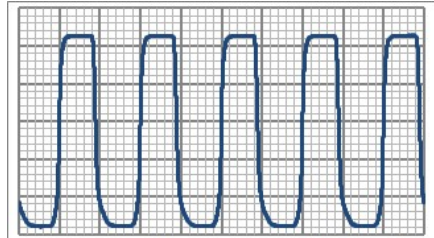

General Note

TT Electronics reserves the right to make changes in product specification without notice or liability. All information is subject to TT Electronics' own data and is considered accurate at time of going to print.

TT Electronics | OPTEK Technology
2900 E. Plano Pkwy, Plano, TX 75074 | Ph: +1 972 323 2200
www.ttelectronics.com | sensors@ttelectronics.com

Looking for pricing, stock, or lifecycle information?

Click below to explore more details on WIN SOURCE:

 [View OPF520 on WIN SOURCE](#)

 [TT Electronics](#) Information

Optimize Your Supply Chain with WIN SOURCE Solutions

-  Global Sourcing Solution
-  Obsolete Management
-  Cost Control Management
-  Shortage Management
-  Alternative Solution
-  Excess Inventory Management