



Integrated Power Hybrid IC for
Appliance Motor Drive Applications

IRAMX20UP60A

iMOTION™ Series

20A, 600V

with open Emitter Pins

Description

International Rectifier's IRAMX20UP60A is a 20A, 600V Integrated Power Hybrid IC for Appliance Motor Drives applications such as air conditioning systems and compressor drivers as well as in light industrial application. IR's technology offers an extremely compact, high performance AC motor-driver in a single isolated package to simplify design.

This advanced HIC is a combination of IR's low $V_{CE(on)}$ Punch-Through IGBT technology and the industry benchmark 3 phase high voltage, high speed driver in a fully isolated thermally enhanced package.

A built-in temperature monitor and input logic protection function, along with the short-circuit rated IGBTs and integrated under-voltage lockout function, deliver high level of protection and fail-safe operation. Using a Single in line package (SiP2) with heatspreader for the power die along with full transfer mold structure minimizes PCB space and resolves isolation problems to heatsink.

Features

- Integrated Gate Drivers
- Temperature Monitor
- Overcurrent shutdown
- Fully Isolated Package
- Low VCE (on) Non Punch Through IGBT Technology.
- Undervoltage lockout for all channels
- Matched propagation delay for all channels
- 5V Schmitt-triggered input logic
- Cross-conduction prevention logic
- Lower di/dt gate driver for better noise immunity
- Motor Power range 1~2kW / 85~253 Vac
- Isolation 2000V_{RMS} min
- Recognized by UL (File Number: E252584)



Absolute Maximum Ratings

Parameter	Description	Max. Value	Units
V_{CES} / V_{RRM}	IGBT/Diode Blocking Voltage	600	V
V^+	Positive Bus Input Voltage	450	
$I_O @ T_C=25^\circ C$	RMS Phase Current (Note 1)	20	A
$I_O @ T_C=100^\circ C$	RMS Phase Current (Note 1)	10	
I_O	Pulsed RMS Phase Current (Note 2)	35	
F_{PWM}	PWM Carrier Frequency	20	kHz
P_d	Power dissipation per IGBT @ $T_C = 25^\circ C$	38	W
V_{ISO}	Isolation Voltage (1min)	2000	V _{RMS}
T_J (IGBT & Diodes)	Operating Junction temperature Range	-40 to +150	°C
T_J (Driver IC)	Operating Junction temperature Range	-40 to +150	
T	Mounting torque Range (M3 screw)	0.5 to 0.6	Nm

Note 1: Sinusoidal Modulation at $V^+=400V$, $T_J=150^\circ C$, $F_{PWM}=16kHz$, Modulation Depth=0.8, PF=0.6, See Figure 3.

Note 2: $t_p < 100ms$; $T_C=25^\circ C$; $F_{PWM}=16kHz$.

IRAMX20UP60A

Internal Electrical Schematic - IRAMX20UP60A

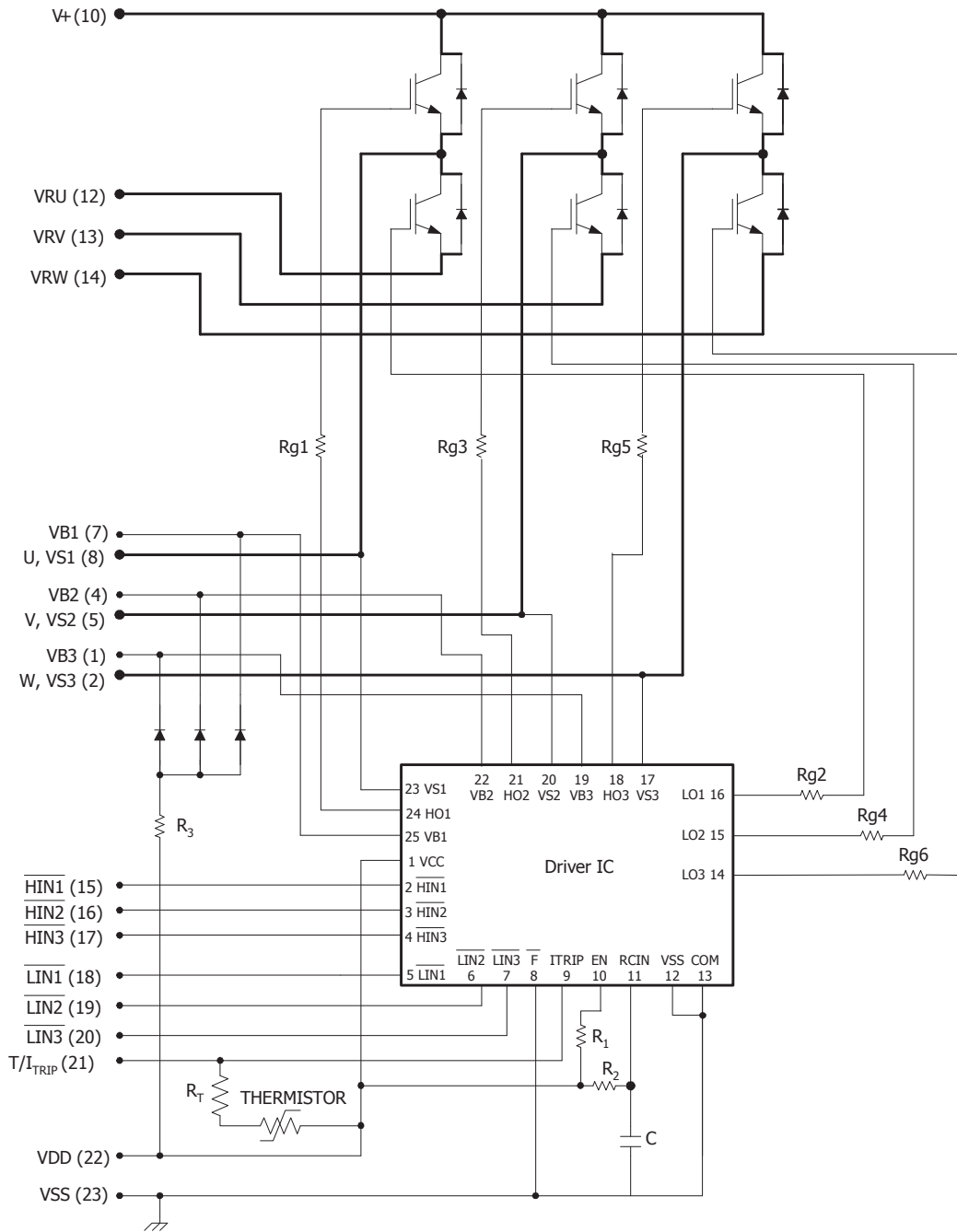

Absolute Maximum Ratings (Continued)

All voltages are absolute referenced to COM.

Symbol	Parameter	Min	Max	Units	Conditions
I_{BDF}	Bootstrap Diode Peak Forward Current	---	4.5	A	$t_p = 10\text{ms}$, $T_J = 150^\circ\text{C}$, $T_C = 100^\circ\text{C}$
$P_{BR \text{ Peak}}$	Bootstrap Resistor Peak Power (Single Pulse)	---	25.0	W	$t_p = 100\mu\text{s}$, $T_C = 100^\circ\text{C}$ ESR / ERJ series
$V_{S1,2,3}$	High Side floating supply offset voltage	$V_{B1,2,3} - 25$	$V_{B1,2,3} + 0.3$	V	
$V_{B1,2,3}$	High Side floating supply voltage	-0.3	600	V	
V_{CC}	Low Side and logic fixed supply voltage	-0.3	20	V	
V_{IN}	Input voltage LIN, HIN, T/I _{Trip}	-0.3	Lower of ($V_{SS} + 15\text{V}$) or $V_{CC} + 0.3\text{V}$	V	

Inverter Section Electrical Characteristics @ $T_J = 25^\circ\text{C}$

Symbol	Parameter	Min	Typ	Max	Units	Conditions
$V_{(BR)CES}$	Collector-to-Emitter Breakdown Voltage	600	---	---	V	$V_{IN} = 5\text{V}$, $I_C = 250\mu\text{A}$
$\Delta V_{(BR)CES} / \Delta T$	Temperature Coeff. Of Breakdown Voltage	---	0.3	---	V/ $^\circ\text{C}$	$V_{IN} = 5\text{V}$, $I_C = 1.0\text{mA}$ ($25^\circ\text{C} - 150^\circ\text{C}$)
$V_{CE(ON)}$	Collector-to-Emitter Saturation Voltage	---	1.75	2.15	V	$I_C = 10\text{A}$, $V_{CC} = 15\text{V}$
		---	2.10	2.60		$I_C = 10\text{A}$, $V_{CC} = 15\text{V}$, $T_J = 150^\circ\text{C}$
I_{CES}	Zero Gate Voltage Collector Current	---	5	80	μA	$V_{IN} = 5\text{V}$, $V^+ = 600\text{V}$
		---	165	---		$V_{IN} = 5\text{V}$, $V^+ = 600\text{V}$, $T_J = 150^\circ\text{C}$
V_{FM}	Diode Forward Voltage Drop	---	1.90	2.60	V	$I_C = 10\text{A}$
		---	1.50	2.20		$I_C = 10\text{A}$, $T_J = 150^\circ\text{C}$
V_{BDFM}	Bootstrap Diode Forward Voltage Drop	--	--	1.25	V	$I_F = 1\text{A}$
		---	---	1.10		$I_F = 1\text{A}$, $T_J = 125^\circ\text{C}$
R_{BR}	Bootstrap Resistor Value	---	22	---	Ω	
$\Delta R_{BR} / R_{BR}$	Bootstrap Resistor Tolerance	---	---	± 5	%	

IRAMX20UP60A

Inverter Section Switching Characteristics @ $T_J = 25^\circ\text{C}$

Symbol	Parameter	Min	Typ	Max	Units	Conditions
E_{ON}	Turn-On Switching Loss	---	390	490	μJ	$I_C=10\text{A}$, $V^+=400\text{V}$ $V_{CC}=15\text{V}$, $L=2\text{mH}$ Energy losses include "tail" and diode reverse recovery See CT1
E_{OFF}	Turn-Off Switching Loss	---	150	200		
E_{TOT}	Total Switching Loss	---	540	690		
E_{REC}	Diode Reverse Recovery energy	---	35	70		
t_{RR}	Diode Reverse Recovery time	---	100	---	ns	See CT1
E_{ON}	Turn-on Switching Loss	---	620	780	μJ	$I_C=10\text{A}$, $V^+=400\text{V}$ $V_{CC}=15\text{V}$, $L=2\text{mH}$, $T_J=150^\circ\text{C}$ Energy losses include "tail" and diode reverse recovery See CT1
E_{OFF}	Turn-off Switching Loss	---	305	400		
E_{TOT}	Total Switching Loss	---	925	1180		
E_{REC}	Diode Reverse Recovery energy	---	65	135		
t_{RR}	Diode Reverse Recovery time	---	130	---	ns	See CT1
Q_G	Turn-On IGBT Gate Charge	---	56	84	nC	$I_C=15\text{A}$, $V^+=400\text{V}$, $V_{GE}=15\text{V}$
RBSOA	Reverse Bias Safe Operating Area	FULL SQUARE				$T_J=150^\circ\text{C}$, $I_C=10\text{A}$, $V_P=600\text{V}$ $V^+=450\text{V}$ $V_{CC}=+15\text{V}$ to 0V See CT3
SCSOA	Short Circuit Safe Operating Area	10	---	---	μs	$T_J=150^\circ\text{C}$, $V_P=600\text{V}$, $V^+=360\text{V}$, $V_{CC}=+15\text{V}$ to 0V See CT2
I_{CSC}	Short Circuit Collector Current	---	140	---	A	$T_J=150^\circ\text{C}$, $V_P=600\text{V}$, $t_{SC}<10\mu\text{s}$ $V^+=360\text{V}$, $V_{GE}=15\text{V}$ $V_{CC}=+15\text{V}$ to 0V See CT2

Recommended Operating Conditions Driver Function

The Input/Output logic timing diagram is shown in Figure 1. For proper operation the device should be used within the recommended conditions. All voltages are absolute referenced to COM. The V_S offset is tested with all supplies biased at 15V differential (Note 3)

Symbol	Definition	Min	Max	Units
$V_{B1,2,3}$	High side floating supply voltage	V_S+12	V_S+20	V
$V_{S1,2,3}$	High side floating supply offset voltage	Note 4	450	
V_{CC}	Low side and logic fixed supply voltage	12	20	V
$V_{T/TRIP}$	T/I_{TRIP} input voltage	V_{SS}	$V_{SS}+5$	V
V_{IN}	Logic input voltage LIN, HIN	V_{SS}	$V_{SS}+5$	

Note 3: For more details, see IR21365 data sheet

Note 4: Logic operational for V_S from COM-5V to COM+600V. Logic state held for V_S from COM-5V to COM- V_{BS} .
(please refer to DT97-3 for more details)

Static Electrical Characteristics Driver Function

$V_{BIAS} (V_{CC}, V_{BS1,2,3})=15V$, unless otherwise specified. The V_{IN} and I_{IN} parameters are referenced to COM and are applicable to all six channels. (Note 3)

Symbol	Definition	Min	Typ	Max	Units
V_{IH}	Logic "0" input voltage	3.0	---	---	V
V_{IL}	Logic "1" input voltage	---	---	0.8	V
V_{CCUV+}, V_{BSUV+}	V_{CC} and V_{BS} supply undervoltage Positive going threshold	10.6	11.1	11.6	V
V_{CCUV-}, V_{BSUV-}	V_{CC} and V_{BS} supply undervoltage Negative going threshold	10.4	10.9	11.4	V
V_{CCUVH}, V_{BSUVH}	V_{CC} and V_{BS} supply undervoltage lock-out hysteresis	---	0.2	---	V
$V_{IN, clamp}$	Input Clamp Voltage (HIN, LIN, T/I _{TRIP}) $I_{IN}=10\mu A$	4.9	5.2	5.5	V
I_{QBS}	Quiescent V_{BS} supply current $V_{IN}=0V$	---	---	165	μA
I_{QCC}	Quiescent V_{CC} supply current $V_{IN}=0V$	---	---	3.35	mA
I_{LK}	Offset Supply Leakage Current	---	---	60	μA
I_{IN+}	Input bias current $V_{IN}=5V$	---	200	300	μA
I_{IN-}	Input bias current $V_{IN}=0V$	---	100	220	μA
T/I_{TRIP+}	T/I _{TRIP} bias current $V_{ITRIP}=5V$	---	30	100	μA
T/I_{TRIP-}	T/I _{TRIP} bias current $V_{ITRIP}=0V$	---	0	1	μA
$V(T/I_{TRIP})$	T/I _{TRIP} threshold Voltage	3.85	4.30	4.75	V
$V(T/I_{TRIP}, HYS)$	T/I _{TRIP} Input Hysteresis	---	0.07	---	V

Dynamic Electrical Characteristics

Driver only timing unless otherwise specified.

Symbol	Parameter	Min	Typ	Max	Units	Conditions
T_{ON}	Input to Output propagation turn-on delay time (see fig.11)	---	600	---	ns	$V_{CC}=V_{BS}= 15V, I_C=10A, V^+=400V$
T_{OFF}	Input to Output propagation turn-off delay time (see fig. 11)	---	700	---	ns	
T_{FLIN}	Input Filter time (HIN, LIN)	100	200	---	ns	$V_{IN}=0$ & $V_{IN}=5V$
$T_{BLT-Trip}$	I _{TRIP} Blanking Time	100	150	---	ns	$V_{IN}=0$ & $V_{IN}=5V$
D_T	Dead Time ($V_{BS}=V_{DD}=15V$)	220	290	360	ns	$V_{BS}=V_{CC}=15V$
M_T	Matching Propagation Delay Time (On & Off)	---	40	75	ns	$V_{CC}= V_{BS}= 15V$, external dead time > 400ns
$T_{T/ITrip}$	T/I _{trip} to six switch to turn-off propagation delay (see fig. 2)	---	---	1.75	μs	$V_{CC}=V_{BS}= 15V, I_C=10A, V^+=400V$
$T_{FLT-CLR}$	Post T/I _{trip} to six switch to turn-off clear time (see fig. 2)	---	7.7	---	ms	$T_C = 25^\circ C$
		---	6.7	---		$T_C = 100^\circ C$

IRAMX20UP60A

Thermal and Mechanical Characteristics

Symbol	Parameter	Min	Typ	Max	Units	Conditions
$R_{th(J-C)}$	Thermal resistance, per IGBT	---	1.5	2.2	°C/W	Flat, greased surface. Heatsink compound thermal conductivity 1W/mK
$R_{th(J-C)}$	Thermal resistance, per Diode	---	5	5.5		
$R_{th(C-S)}$	Thermal resistance, C-S	---	0.1	---		
C_D	Creepage Distance	3.2	---	---	mm	See outline Drawings

Internal NTC - Thermistor Characteristics

Parameter	Definition	Min	Typ	Max	Units	Conditions
R_{25}	Resistance	97	100	103	k Ω	$T_C = 25^\circ\text{C}$
R_{125}	Resistance	2.25	2.52	2.80	k Ω	$T_C = 125^\circ\text{C}$
B	B-constant (25-50°C)	4165	4250	4335	k	$R_2 = R_1 e^{[B(1/T_2 - 1/T_1)]}$
Temperature Range		-40		125	°C	
Typ. Dissipation constant			1		mW/°C	$T_C = 25^\circ\text{C}$

Input-Output Logic Level Table

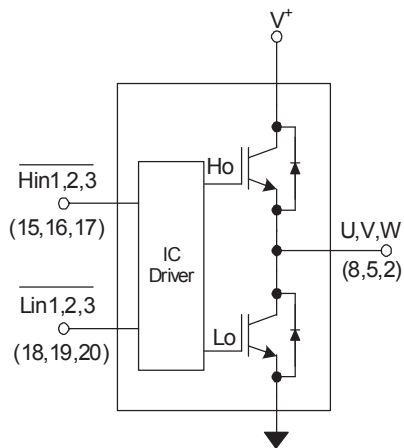

T/I_{TRIP}	$\overline{\text{HIN}}_{1,2,3}$	$\overline{\text{LIN}}_{1,2,3}$	U,V,W
0	0	1	V^+
0	1	0	0
0	1	1	Off
1	X	X	Off

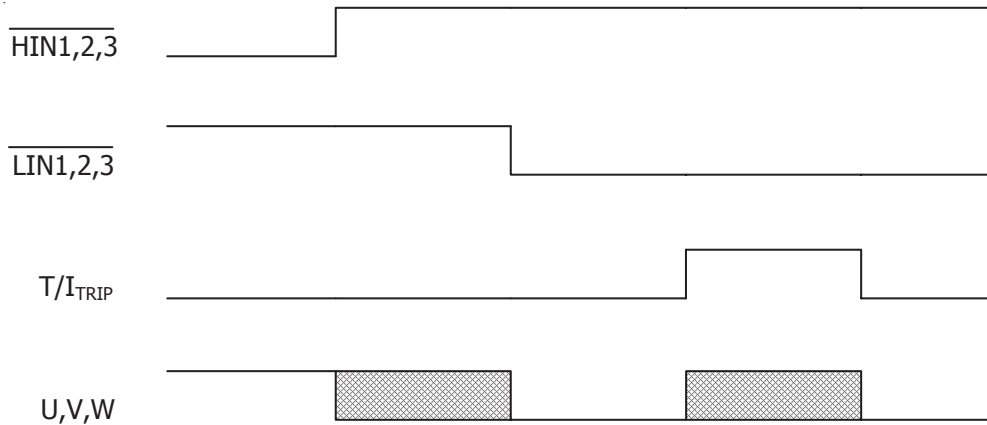

Figure1. Input/Output Timing Diagram

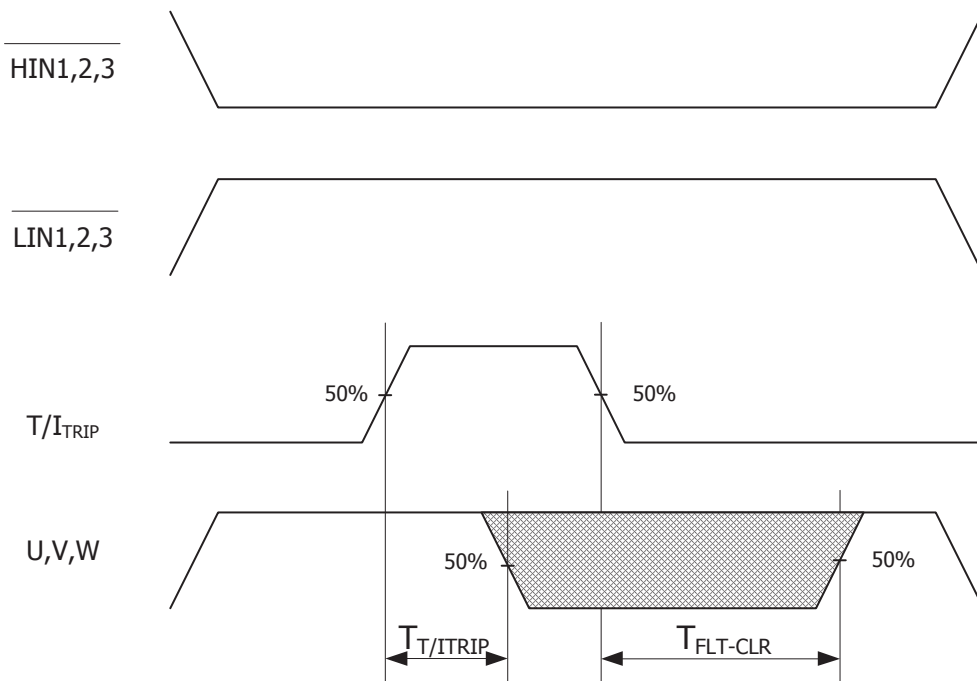

Figure 2. I_{Trip} Timing Waveform

Note 5: The shaded area indicates that both high-side and low-side switches are off and therefore the half-bridge output voltage would be determined by the direction of current flow in the load.

IRAMX20UP60A

Module Pin-Out Description

Pin	Name	Description
1	V_{B3}	High Side Floating Supply Voltage 3
2	W, V_{S3}	Output 3 - High Side Floating Supply Offset Voltage
3	NA	none
4	V_{B2}	High Side Floating Supply voltage 2
5	V, V_{S2}	Output 2 - High Side Floating Supply Offset Voltage
6	NA	none
7	V_{B1}	High Side Floating Supply voltage 1
8	U, V_{S1}	Output 1 - High Side Floating Supply Offset Voltage
9	NA	none
10	V^+	Positive Bus Input Voltage
11	NA	none
12	L_{E1}	Low Side Emitter Connection - Phase 1
13	L_{E2}	Low Side Emitter Connection - Phase 2
14	L_{E3}	Low Side Emitter Connection - Phase 3
15	\overline{H}_{IN1}	Logic Input High Side Gate Driver - Phase 1
16	\overline{H}_{IN2}	Logic Input High Side Gate Driver - Phase 2
17	\overline{H}_{IN3}	Logic Input High Side Gate Driver - Phase 3
18	\overline{L}_{IN1}	Logic Input Low Side Gate Driver - Phase 1
19	\overline{L}_{IN2}	Logic Input Low Side Gate Driver - Phase 2
20	\overline{L}_{IN3}	Logic Input Low Side Gate Driver - Phase 3
21	T/I_{TRIP}	Temperature Monitor and Shut-down Pin
22	V_{CC}	+15V Main Supply
23	V_{SS}	Negative Main Supply

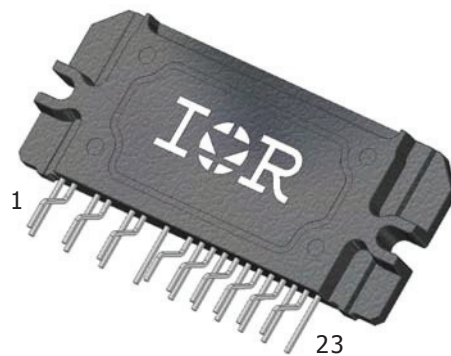

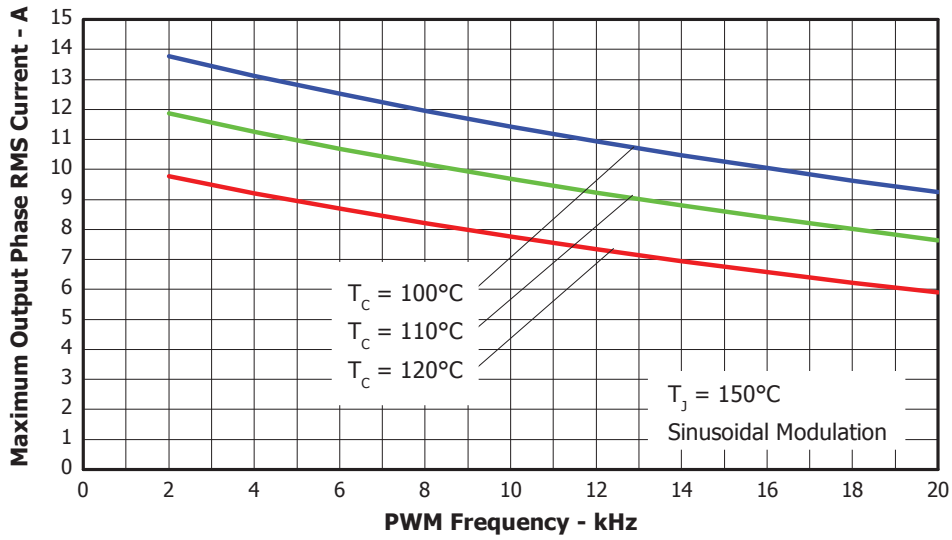

Figure 3. Maximum Sinusoidal Phase Current vs. PWM Switching Frequency
 $V^+=400\text{V}$, $T_j=150^\circ\text{C}$, Modulation Depth=0.8, PF=0.6

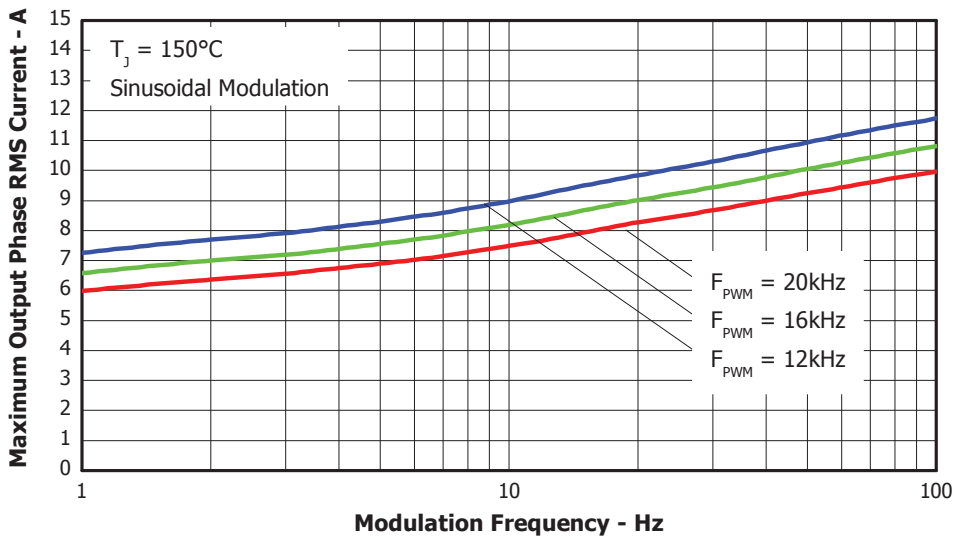

Figure 4. Maximum Sinusoidal Phase Current vs. Modulation Frequency
 $V^+=400\text{V}$, $T_j=150^\circ\text{C}$, $T_c=100^\circ\text{C}$, Modulation Depth=0.8, PF=0.6

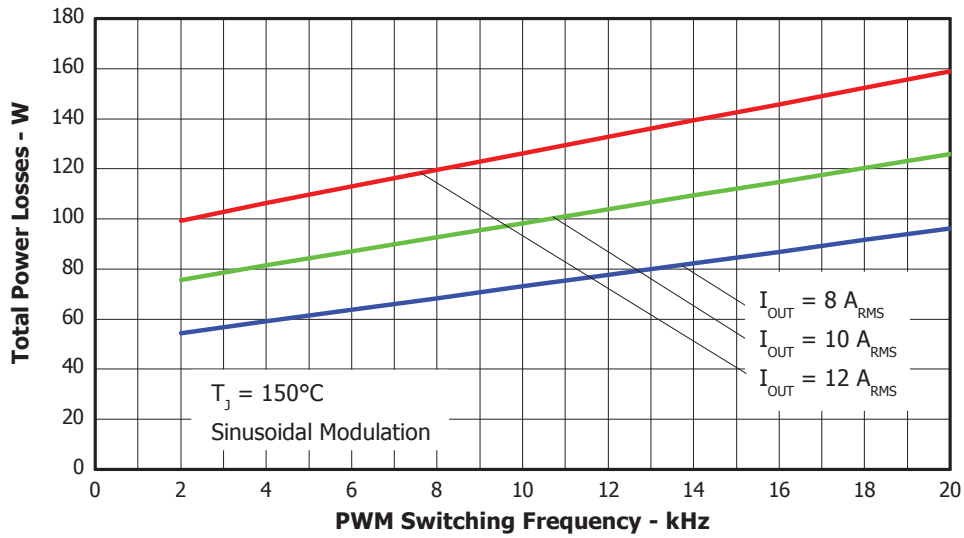

Figure 5. Total Power Losses vs. PWM Switching Frequency, Sinusoidal modulation
 $V^+ = 400\text{V}$, $T_j = 150^\circ\text{C}$, Modulation Depth=0.8, PF=0.6

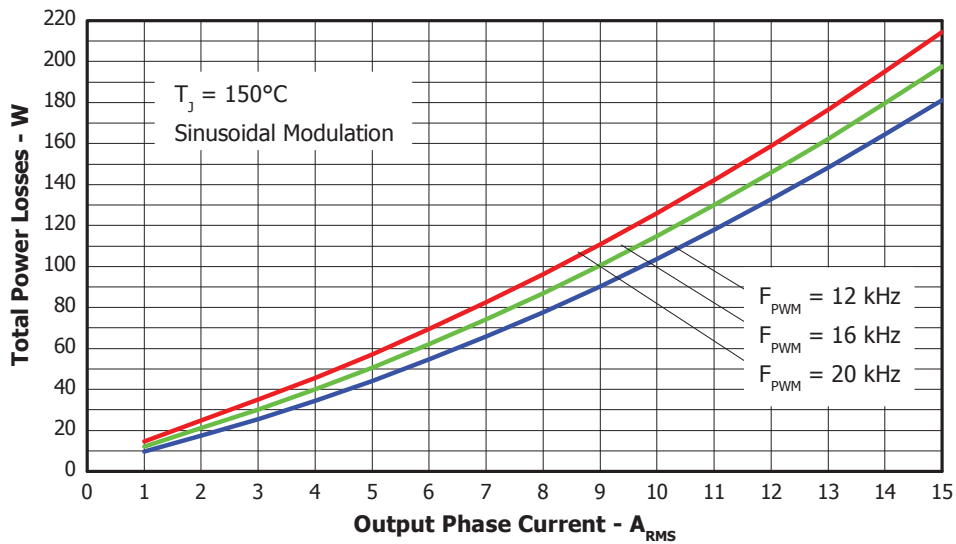

Figure 6. Total Power Losses vs. Output Phase Current, Sinusoidal modulation
 $V_{BUS} = 400\text{V}$, $T_j = 150^\circ\text{C}$, Modulation Depth=0.8, PF=0.6

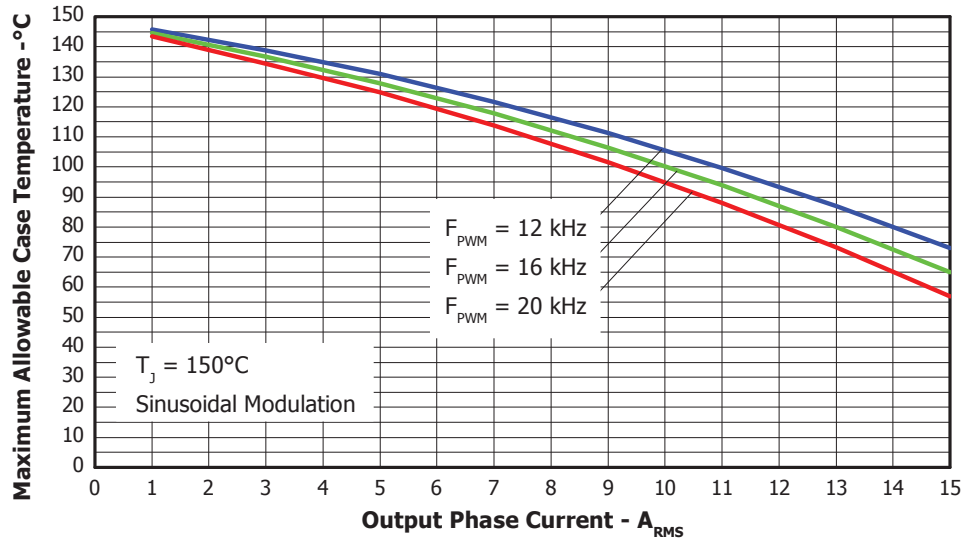

Figure 7. Maximum Allowable Case temperature vs. Output RMS Current per Phase

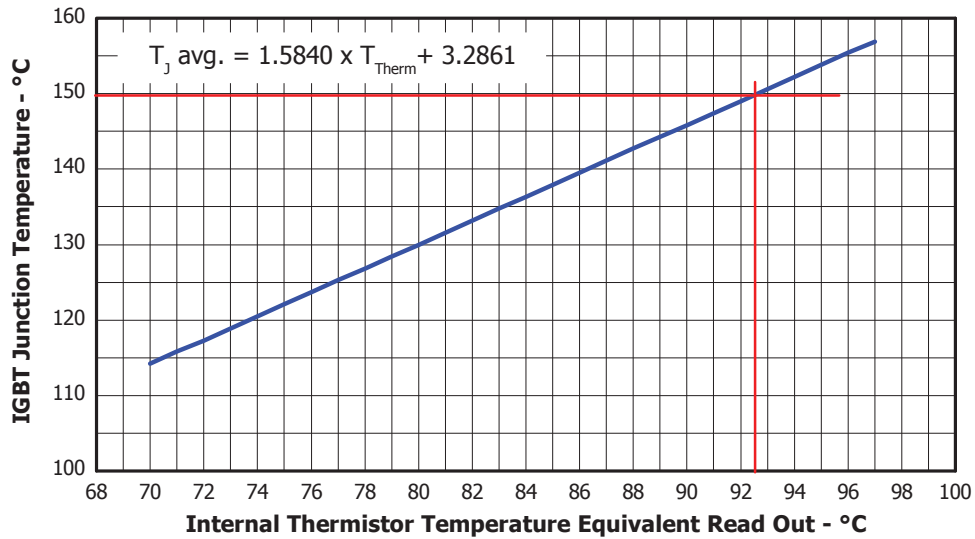

Figure 8. Estimated Maximum IGBT Junction Temperature vs. Thermistor Temperature

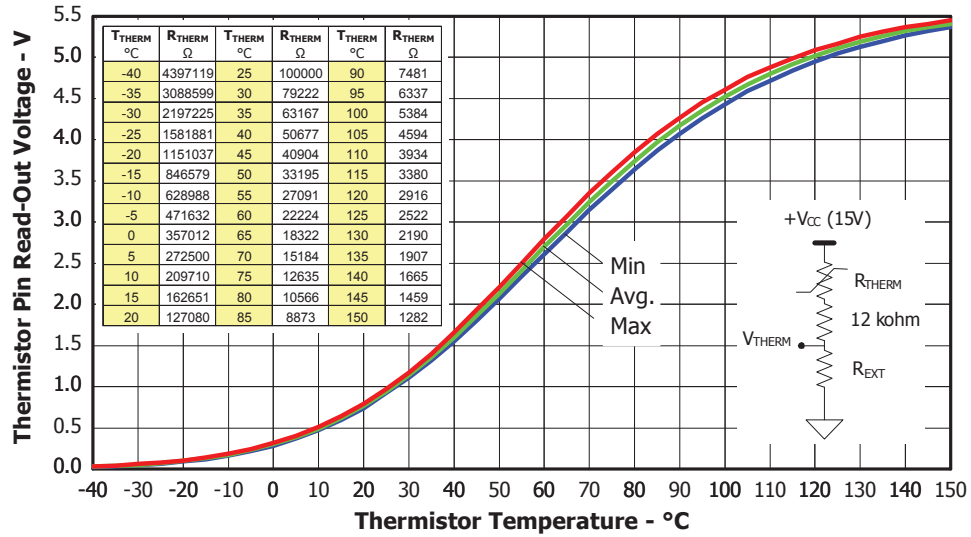

Figure 9. Thermistor Readout vs. Temperature (7.5kohm pull-up resistor, 5V) and Nominal Thermistor Resistance values vs. Temperature Table.

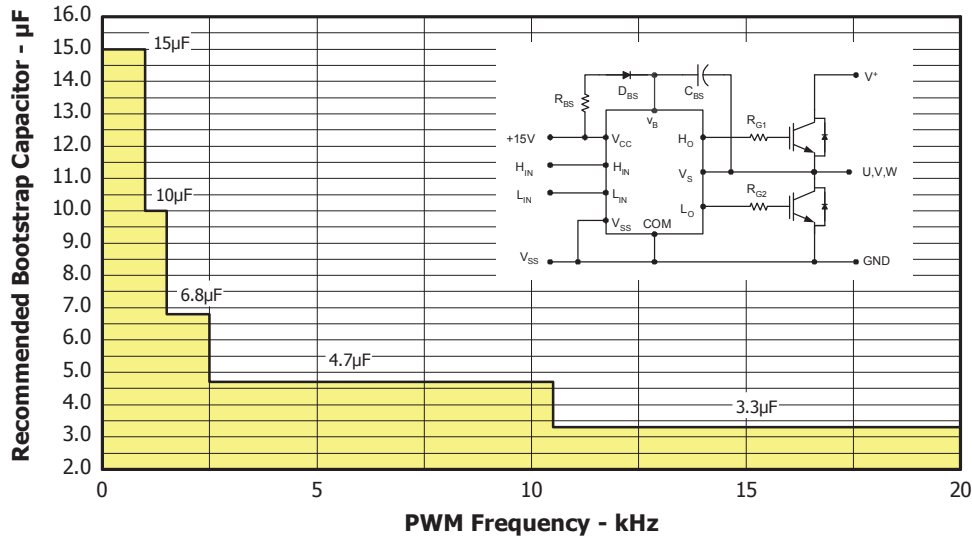

Figure 10. Recommended Bootstrap Capacitor Value vs. Switching Frequency

Figure 11. Switching Parameter Definitions

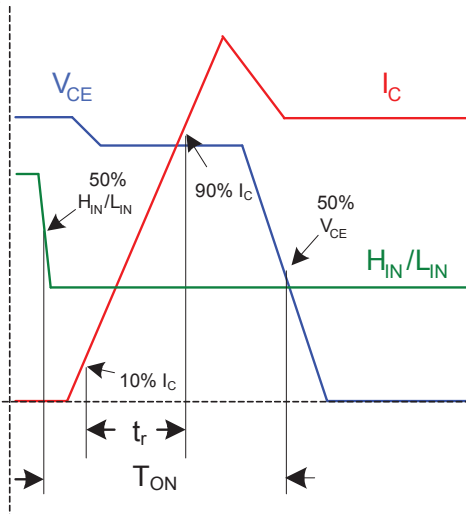

Figure 11a. Input to Output propagation turn-on delay time.

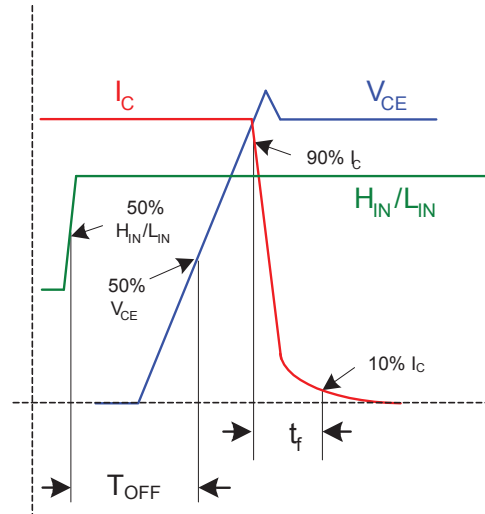

Figure 11b. Input to Output propagation turn-off delay time.

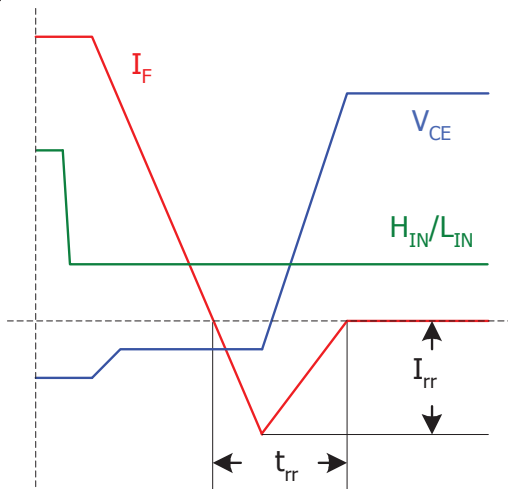

Figure 11c. Diode Reverse Recovery.

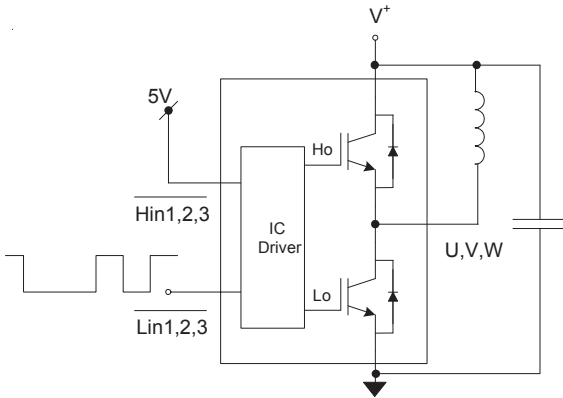

Figure CT1. Switching Loss Circuit

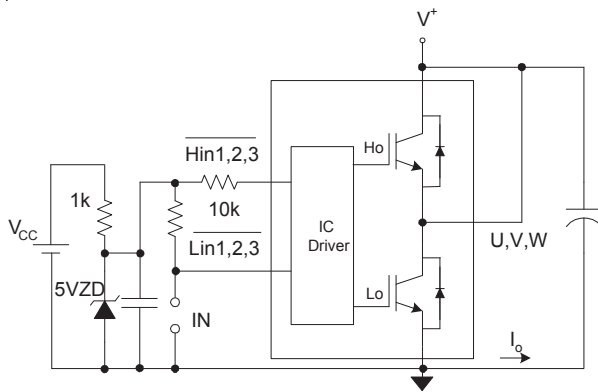
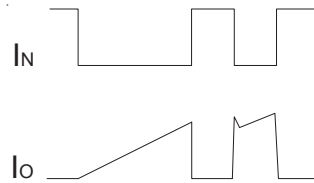

Figure CT2. S.C.SOA Circuit

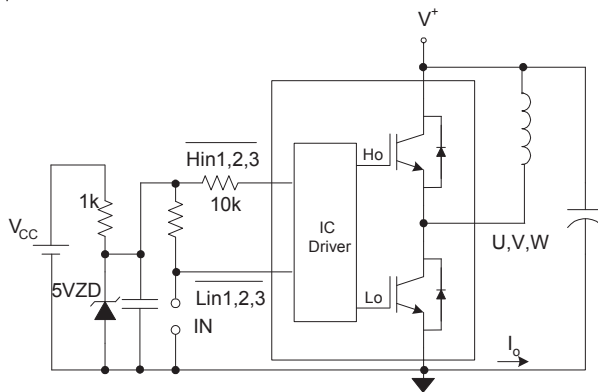
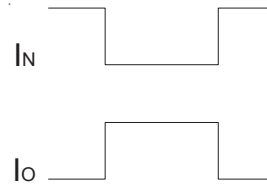
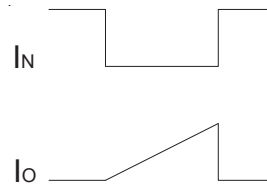
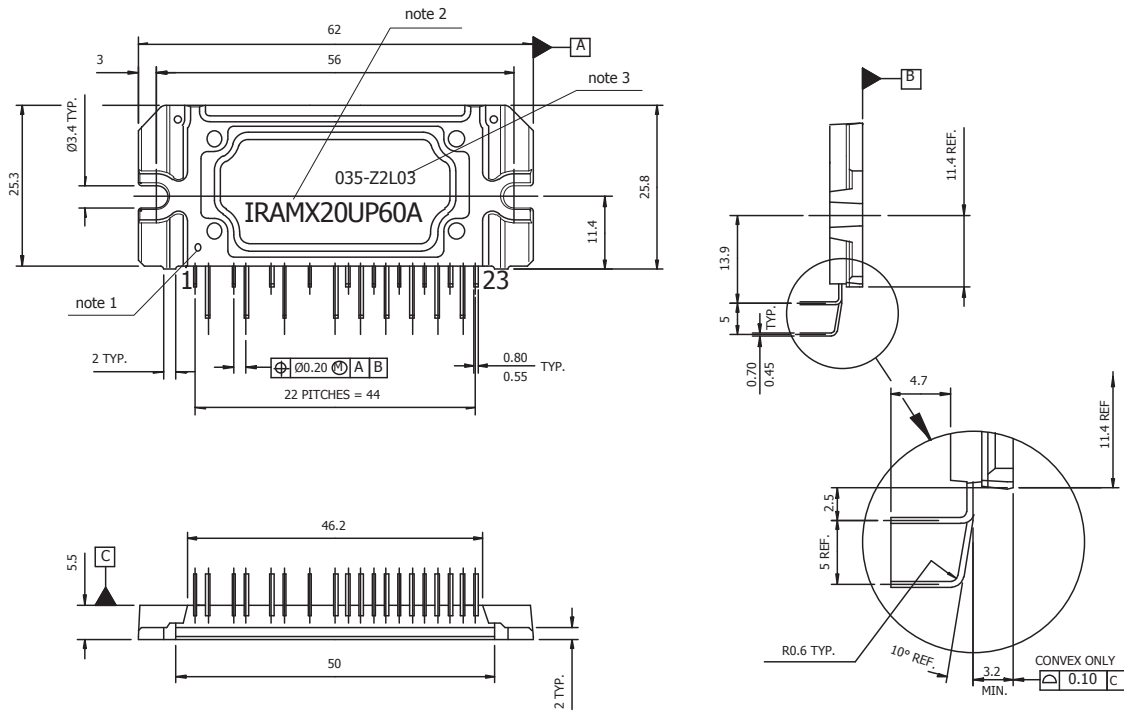

Figure CT3. R.B.SOA Circuit



Package Outline IRAMX20UP60A-2



Notes:



Dimensions in mm

- 1- Marking for pin 1 identification
- 2- Product Part Number
- 3- Lot and Date code marking
- 4- Convex only 0.10mm typical
- 5- Tolerances $\pm 0.5\text{mm}$, unless otherwise stated

For mounting instruction see AN-1049

Looking for pricing, stock, or lifecycle information?

Click below to explore more details on WIN SOURCE:

-  [View IRAMX20UP60A-2 on WIN SOURCE](#)
-  [Infineon Technologies](#) Information

Optimize Your Supply Chain with WIN SOURCE Solutions

-  Global Sourcing Solution
-  Obsolete Management
-  Cost Control Management
-  Shortage Management
-  Alternative Solution
-  Excess Inventory Management