



# THE DATASHEET OF IR4427



# IR4426/IR4427/IR4428(S)&(PbF)

## DUAL LOW SIDE DRIVER

### Features

- Gate drive supply range from 6 to 20V
- CMOS Schmitt-triggered inputs
- Matched propagation delay for both channels
- Outputs out of phase with inputs (IR4426)
- Outputs in phase with inputs (IR4427)
- OutputA out of phase with inputA and OutputB in phase with inputB (IR4428)
- Also available LEAD-FREE

### Descriptions

The IR4426/IR4427/IR4428 (S) is a low voltage, high speed power MOSFET and IGBT driver. Proprietary latch immune CMOS technologies enable ruggedized monolithic construction. Logic inputs are compatible with standard CMOS or LSTTL outputs. The output drivers feature a high pulse current buffer stage designed for minimum driver cross-conduction. Propagation delays between two channels are matched.

### Product Summary

$I_{O+/-}$	1.5A / 1.5A
$V_{OUT}$	6V - 20V
$t_{on/off}$ (typ.)	85 & 65 ns

### Packages

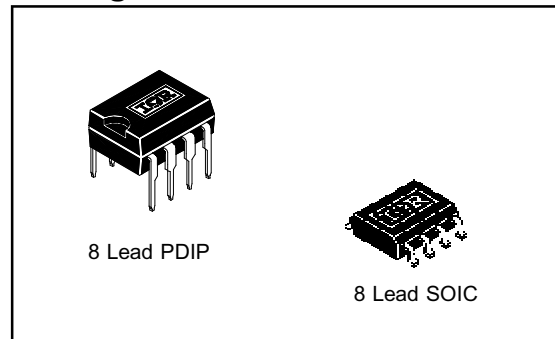

### Typical Connection

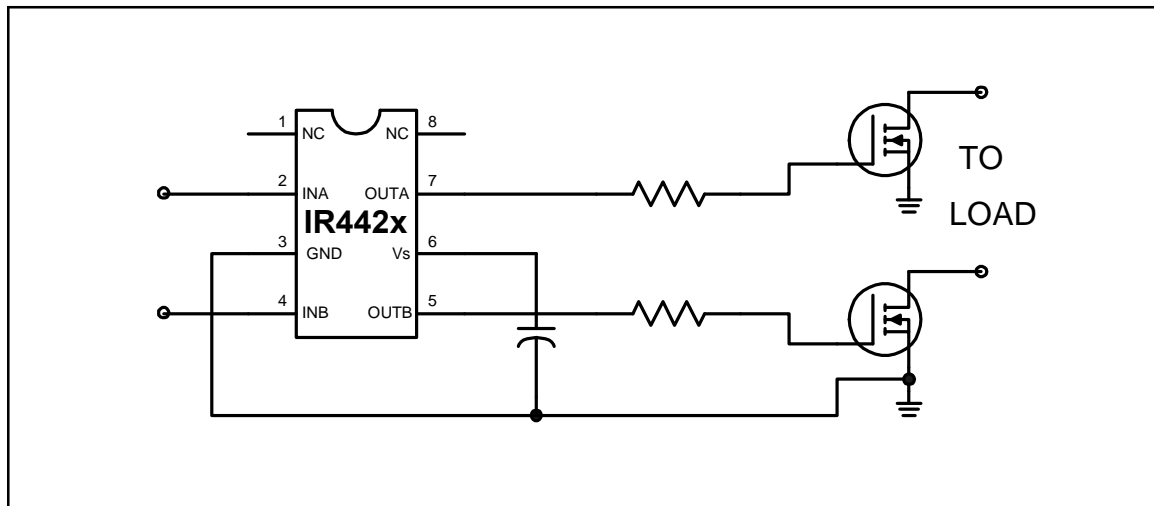

# IR4426/IR4427/IR4428(S) & (PbF)

## ADVANCE INFORMATION

International  
IR Rectifier

### Absolute Maximum Ratings

Absolute maximum ratings indicate sustained limits beyond which damage to the device may occur. All voltage parameters are absolute voltages referenced to GND. The thermal resistance and power dissipation ratings are measured under board mounted and still air conditions.

Symbol	Definition	Min.	Max.	Units	
V <sub>S</sub>	Fixed supply voltage	-0.3	25	V	
V <sub>O</sub>	Output voltage	-0.3	V <sub>S</sub> + 0.3		
V <sub>IN</sub>	Logic input voltage	-0.3	V <sub>S</sub> + 0.3		
P <sub>D</sub>	Package power dissipation @ T <sub>A</sub> ≤ +25°C	(8 Lead PDIP)	—	1.0	W
		(8 lead SOIC)	—	0.625	
R <sub>thJA</sub>	Thermal resistance, junction to ambient	(8 lead PDIP)	—	125	°C/W
		(8 lead SOIC)	—	200	
T <sub>J</sub>	Junction temperature	—	150	°C	
T <sub>S</sub>	Storage temperature	-55	150		
T <sub>L</sub>	Lead temperature (soldering, 10 seconds)	—	300		

### Recommended Operating Conditions

The input/output logic timing diagram is shown in figure 1. For proper operation the device should be used within the recommended conditions. All voltage parameters are absolute voltages referenced to GND.

Symbol	Definition	Min.	Max.	Units
V <sub>S</sub>	Fixed supply voltage	6	20	V
V <sub>O</sub>	Output voltage	0	V <sub>S</sub>	
V <sub>IN</sub>	Logic input voltage	0	V <sub>S</sub>	
T <sub>A</sub>	Ambient temperature	-40	125	°C

### DC Electrical Characteristics

V<sub>BIAS</sub> (V<sub>S</sub>) = 15V, T<sub>A</sub> = 25°C unless otherwise specified. The V<sub>IN</sub> and I<sub>IN</sub> parameters are referenced to GND and are applicable to input leads: INA and INB. The V<sub>O</sub> and I<sub>O</sub> parameters are referenced to GND and are applicable to the output leads: OUTA and OUTB.

Symbol	Definition	Min.	Typ.	Max.	Units	Test Conditions
V <sub>IH</sub>	Logic "0" input voltage (OUTA=LO, OUTB=LO) (IR4426)	2.7	—	—	V	
	Logic "1" input voltage (OUTA=HI, OUTB=HI) (IR4427)					
	Logic "0" input voltage (OUTA=LO), Logic "1" input voltage (OUTB=HI) (IR4428)					

**ADVANCE INFORMATION**

**DC Electrical Characteristics cont.**

$V_{BIAS} (V_S) = 15V$ ,  $T_A = 25^\circ C$  unless otherwise specified. The  $V_{IN}$ , and  $I_{IN}$  parameters are referenced to GND and are applicable to input leads: INA and INB. The  $V_O$  and  $I_O$  parameters are referenced to GND and are applicable to the output leads: OUTA and OUTB.

Symbol	Definition	Min.	Typ.	Max.	Units	Test Conditions
$V_{IL}$	Logic "1" input voltage (OUTA=HI, OUTB=HI) (IR4426) Logic "0" input voltage (OUTA=LO, OUTB=LO) (IR4427) Logic "1" input voltage (OUTA=HI), Logic "0" input voltage (OUTB=LO) (IR4428)	—	—	0.8	V	
$V_{OH}$	High level output voltage, $V_{BIAS}-V_O$	—	—	1.2		$I_O = 0mA$
$V_{OL}$	Low level output voltage, $V_O$	—	—	0.1		$I_O = 0mA$
$I_{IN+}$	Logic "1" input bias current (OUT=HI)	—	5	15	$\mu A$	$V_{IN} = 0V$ (IR4426) $V_{IN} = V_S$ (IR4427) $V_{INA} = 0V$ (IR4428) $V_{INB} = V_S$ (IR4428)
$I_{IN-}$	Logic "0" input bias current (OUT=LO)	—	-10	-30		$V_{IN} = V_S$ (IR4426) $V_{IN} = 0V$ (IR4427) $V_{INA} = V_S$ (IR4428) $V_{INB} = 0V$ (IR4428)
$I_{QS}$	Quiescent $V_S$ supply current	—	100	200		$V_{IN} = 0V$ or $V_S$
$I_{O+}$	Output high short circuit pulsed current	1.5	2.3	—	A	$V_O = 0V$ , $V_{IN} = 0$ (IR4426) $V_O = 0V$ , $V_{IN} = V_S$ (IR4427) $V_O = 0V$ , $V_{INA} = 0$ (IR4428) $V_O = 0V$ , $V_{INB} = V_S$ (IR4428) $PW \leq 10 \mu s$
$I_{O-}$	Output low short circuit pulsed current	1.5	3.3	—		$V_O = 15V$ , $V_{IN} = V_S$ (IR4426) $V_O = 15V$ , $V_{IN} = 0$ (IR4427) $V_O = 15V$ , $V_{INA} = V_S$ (IR4428) $V_O = 15V$ , $V_{INB} = 0$ (IR4428) $PW \leq 10 \mu s$

# IR4426/IR4427/IR4428(S) & (PbF)

ADVANCE INFORMATION

International  
**IR** Rectifier

## AC Electrical Characteristics

$V_{BIAS} (V_S) = 15V$ ,  $C_L = 1000pF$ ,  $T_A = 25^\circ C$  unless otherwise specified.

Symbol	Definition	Min.	Typ.	Max.	Units	Test Conditions
<b>Propagation delay characteristics</b>						
$t_{d1}$	Turn-on propagation delay	—	85	160	ns	figure 4
$t_{d2}$	Turn-off propagation delay	—	65	150		
$t_r$	Turn-on rise time	—	15	35		
$t_f$	Turn-off fall time	—	10	25		

## Functional Block Diagram IR4426

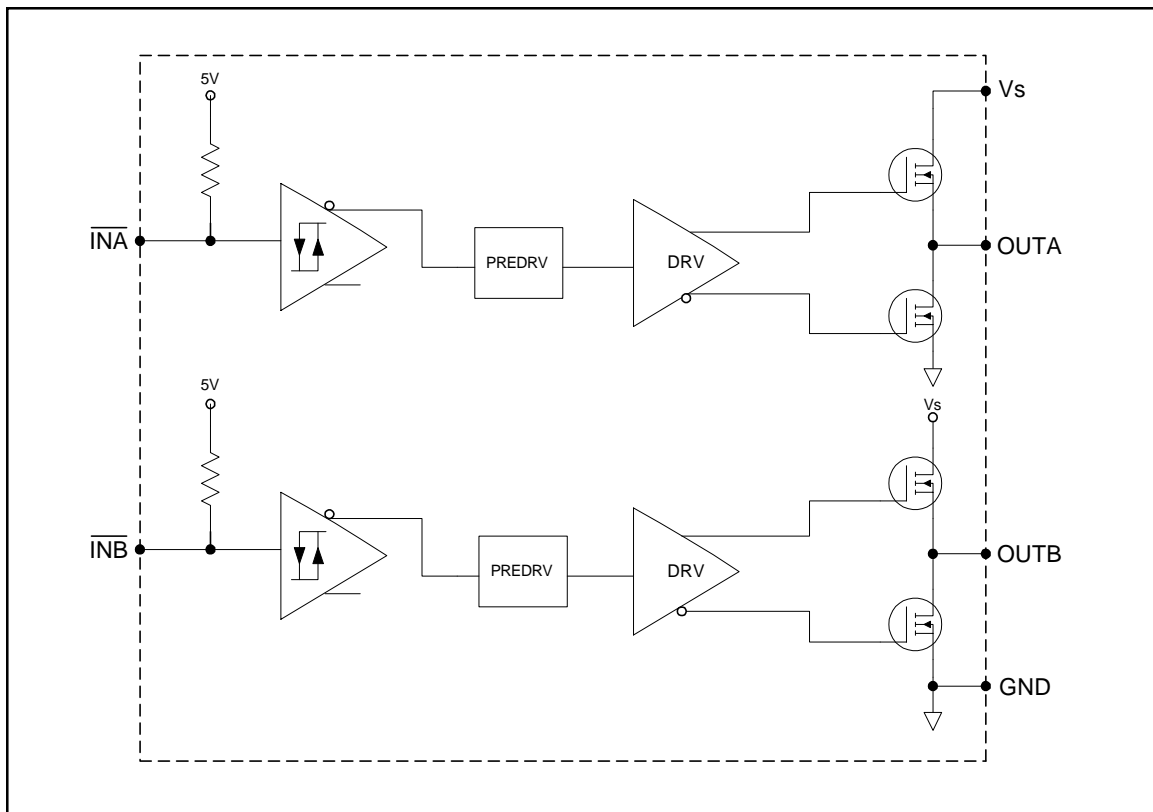

## ADVANCE INFORMATION

### Functional Block Diagram IR4427

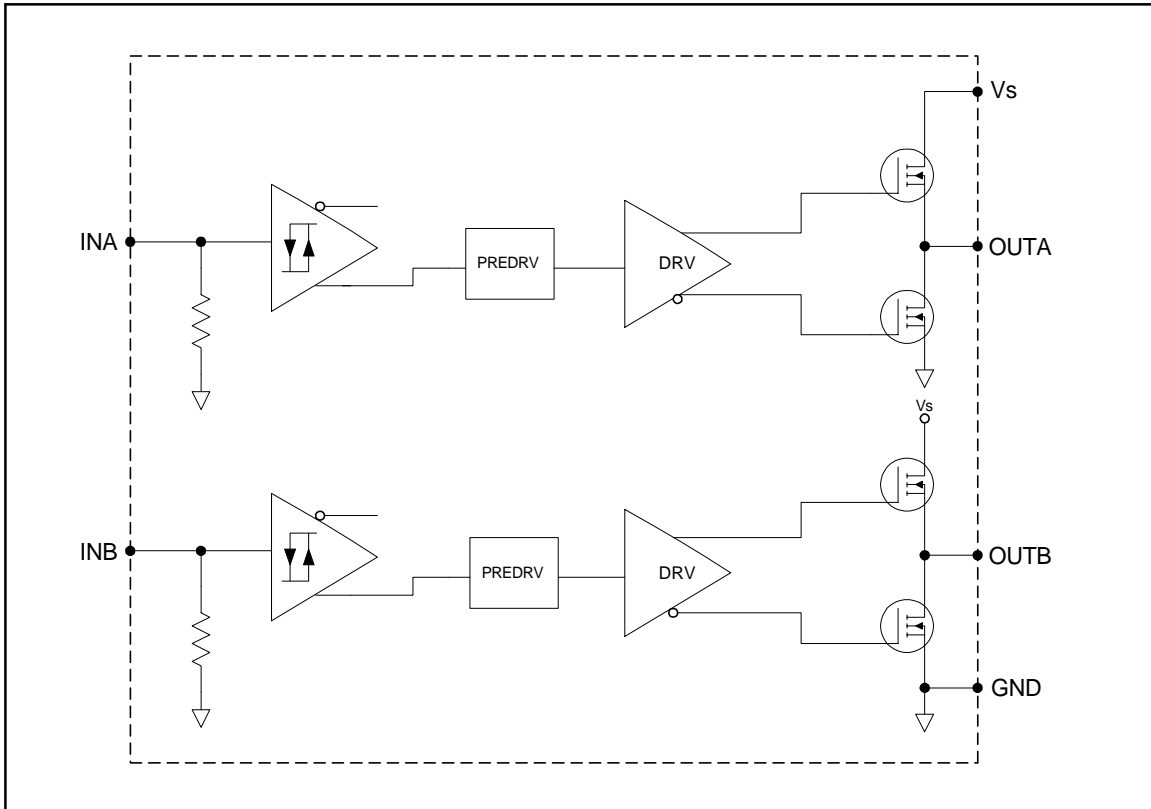

# IR4426/IR4427/IR4428(S) & (PbF)

ADVANCE INFORMATION

International  
**IR** Rectifier

## Functional Block Diagram IR4428

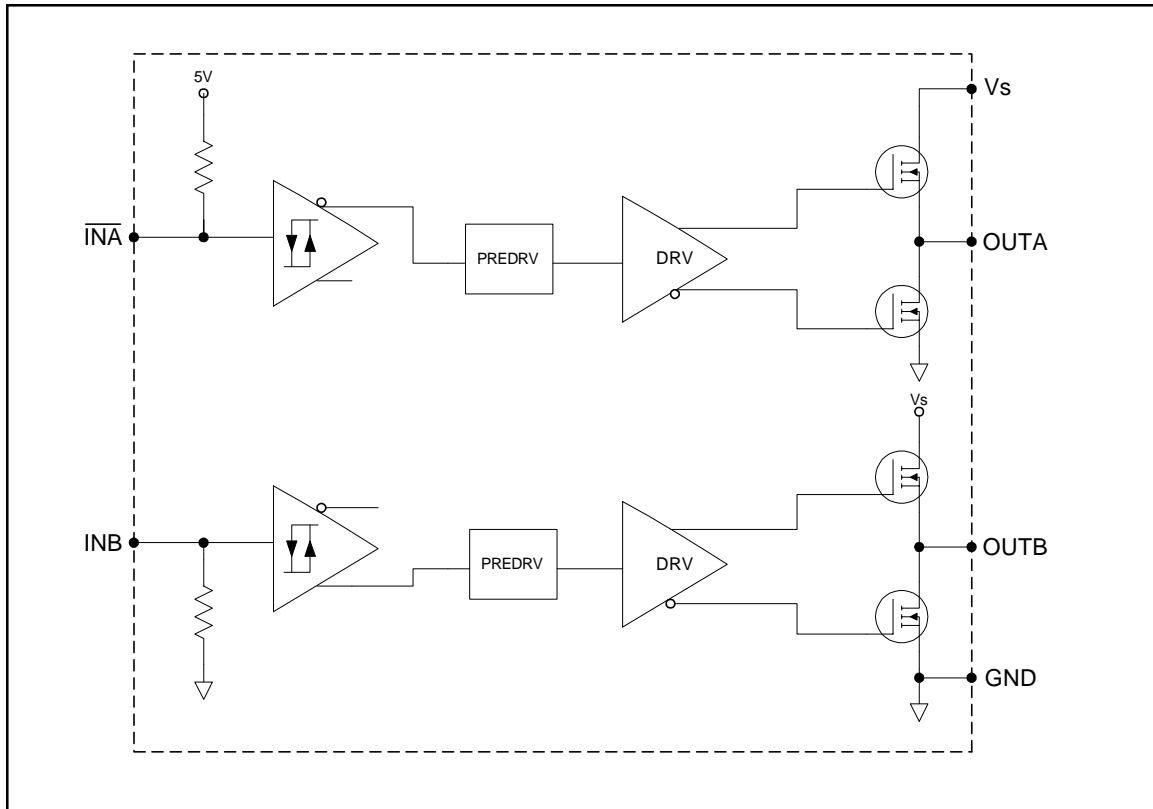

### Lead Definitions

Symbol	Description
$V_s$	Supply voltage
GND	Ground
INA	Logic input for gate driver output (OUTA), out of phase (IR4426, IR4428), in phase (IR4427)
INB	Logic input for gate driver output (OUTB), out of phase (IR4426), in phase (IR4427, IR4428)
OUTA	Gate drive output A
OUTB	Gate drive output B

# IR4426/IR4427/IR4428(S) & (PbF)

## ADVANCE INFORMATION

### Lead Assignments

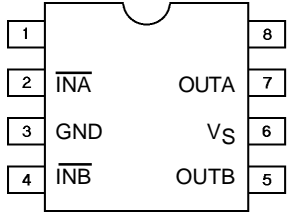
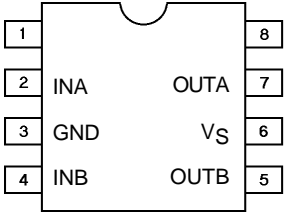
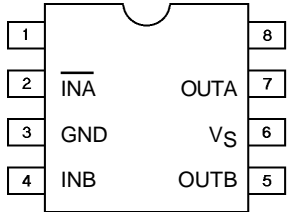
 <p>8 Lead PDIP</p>	 <p>8 Lead PDIP</p>	 <p>8 Lead PDIP</p>
<b>IR4426</b>	<b>IR4427</b>	<b>IR4428</b>
<b>Part Number</b>		

### Lead Assignments

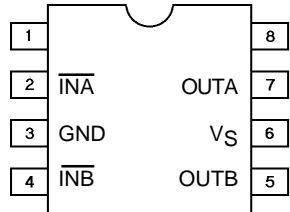
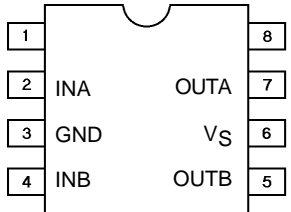
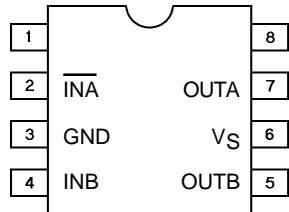
 <p>8 Lead SOIC</p>	 <p>8 Lead SOIC</p>	 <p>8 Lead SOIC</p>
<b>IR4426S</b>	<b>IR4427S</b>	<b>IR4428S</b>
<b>Part Number</b>		

# IR4426/IR4427/IR4428(S) & (PbF)

ADVANCE INFORMATION

International  
**IR** Rectifier

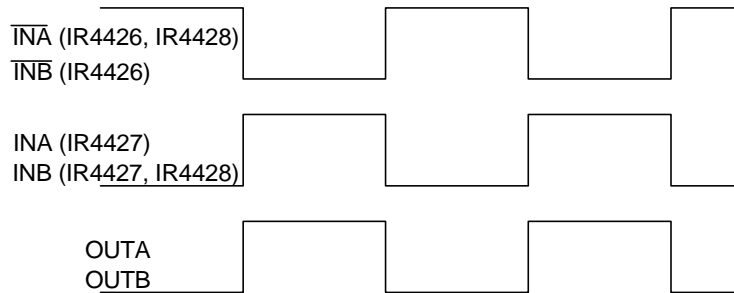

Figure 3. Timing Diagram

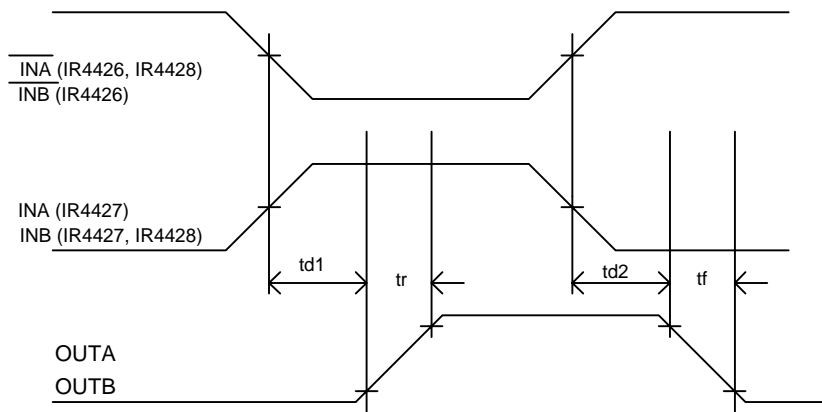

Figure 4. Switching Time Waveforms

# IR4426/IR4427/IR4428(S) & (PbF)

## ADVANCE INFORMATION

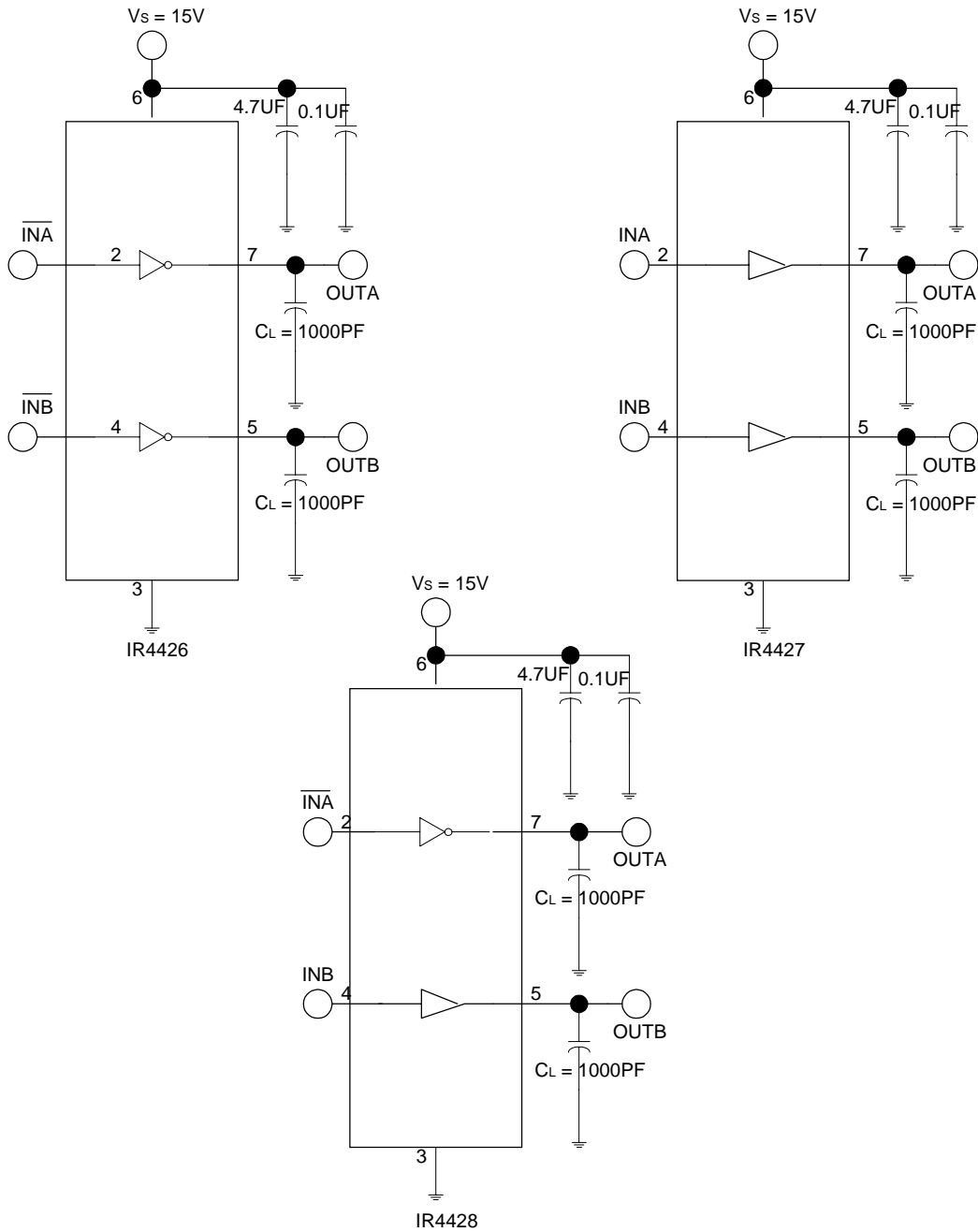

Figure 5. Switching Time Test Circuits

# IR4426/IR4427/IR4428(S) & (PbF)

## ADVANCE INFORMATION

International  
**IR** Rectifier

### Caseoutline

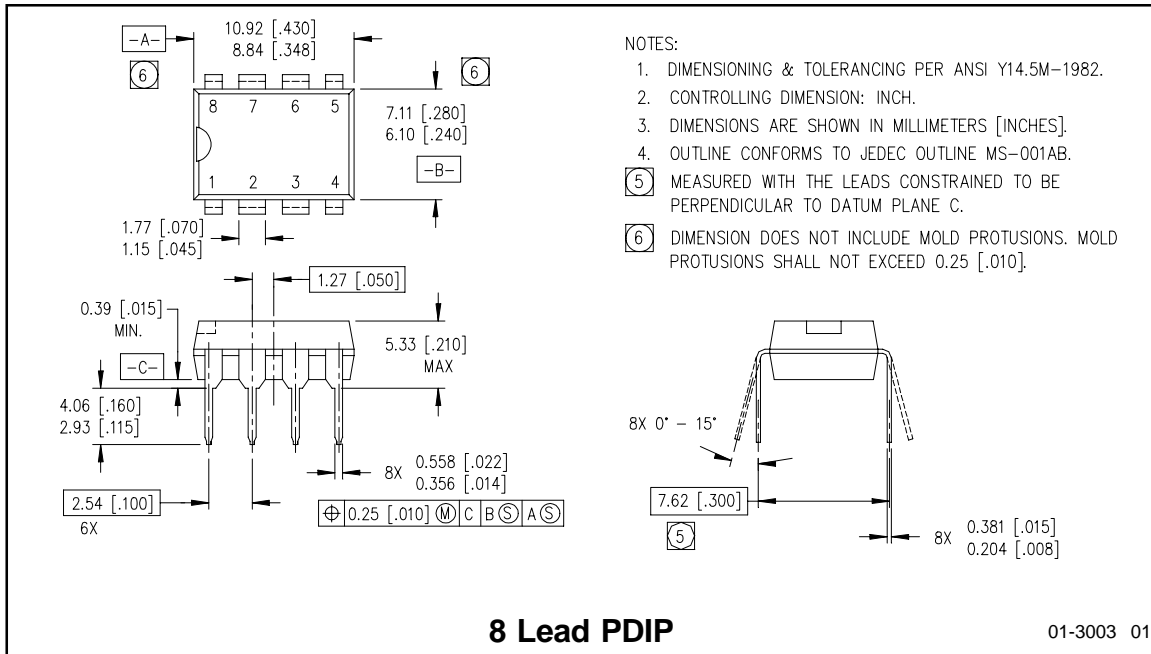

### Tape & Reel

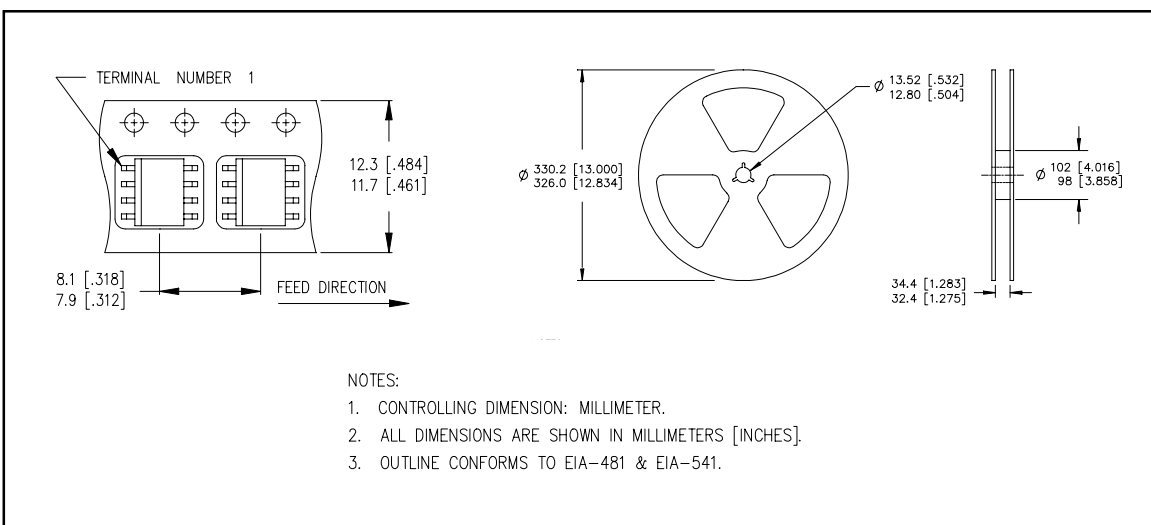

# IR4426/IR4427/IR4428(S) & (PbF)

## ADVANCE INFORMATION

### Case Outline - 8 Lead SOIC

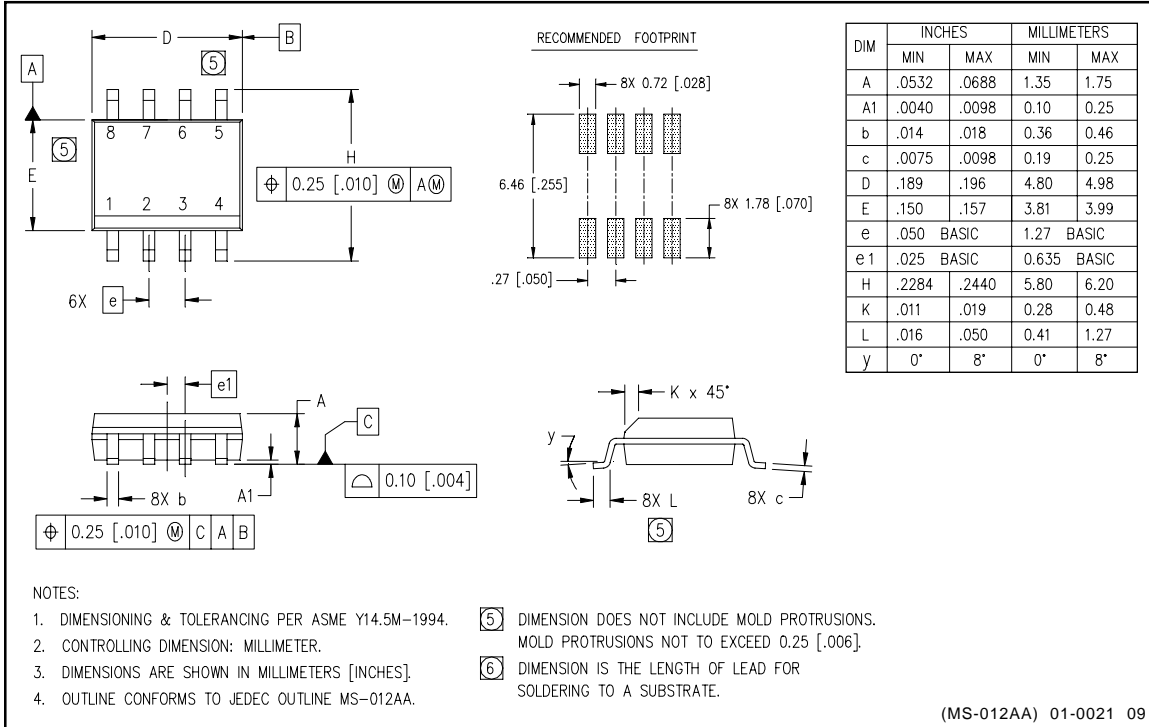

# IR4426/IR4427/IR4428(S)&(PbF)

## ADVANCE INFORMATION

International  
**IR** Rectifier

### LEADFREE PART MARKING INFORMATION

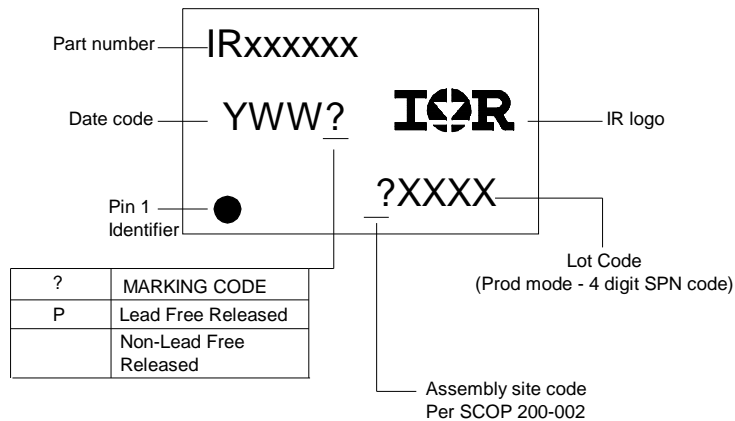

### ORDER INFORMATION

#### Basic Part (Non-Lead Free)

8-Lead PDIP IR4426 order IR4426  
 8-Lead SOIC IR4426S order IR4426S  
 8-Lead PDIP IR4427 order IR4427  
 8-Lead SOIC IR4427S order IR4427S  
 8-Lead PDIP IR4428 order IR4428  
 8-Lead SOIC IR4428S order IR4428S

#### Leadfree Part

8-Lead PDIP IR4426 order IR4426PbF  
 8-Lead SOIC IR4426S order IR4426SPbF  
 8-Lead PDIP IR4427 order IR4427PbF  
 8-Lead SOIC IR4427S order IR4427SPbF  
 8-Lead PDIP IR4428 order IR4428PbF  
 8-Lead SOIC IR4428S order IR4428SPbF



International  
**IR** Rectifier

**IR WORLD HEADQUARTERS:** 233 Kansas St., El Segundo, California 90245 Tel: (310) 252-7105

**This product has been qualified per industrial level**  
*Data and specifications subject to change without notice. 3/3/2008*

## Looking for pricing, stock, or lifecycle information?

Click below to explore more details on WIN SOURCE:

-  [View IR4427 on WIN SOURCE](#)
-  [Infineon Technologies](#) Information

## Optimize Your Supply Chain with WIN SOURCE Solutions

-  Global Sourcing Solution
-  Obsolete Management
-  Cost Control Management
-  Shortage Management
-  Alternative Solution
-  Excess Inventory Management