



**THE DATASHEET OF
IR3E3146**



SPEC No.	EL165191
----------	----------

ISSUE: Jun. 10. 2004

To; _____

S P E C I F I C A T I O N S

Product Type VOLTAGE REFERENCE IC FOR LCD

Model No. IR3E3146
(IR3E3146)

※ This specifications contains 22 pages including the cover and appendix.
If you have any objections, please contact us before issuing purchasing order.

CUSTOMERS ACCEPTANCE

DATE: _____

BY: _____

PRESENTED

BY: H. Fujita
H. Fujita
DEPT. GENERAL MANAGER

REVIEWED BY:

PREPARED BY:

H. Yamaguchi M. Inamori

PRODUCT DEVELOPMENT DEPT. I
ANALOG IC DIVISION
INTEGRATED CIRCUITS GROUP
SHARP CORPORATION

- Handle this document carefully for it contains material protected by international copyright law. Any reproduction, full or in part, of this material is prohibited without the express written permission of the company.

- When using the products covered herein, please observe the conditions written herein and the precautions outlined in the following paragraphs. In no event shall the company be liable for any damages resulting from failure to strictly adhere to the conditions and precautions.
 - (1) The products covered herein are designed and manufactured for the following application areas. When using the products covered herein for the equipment listed in paragraph (2), even for the following application areas, be sure to observe the precautions given in Paragraph (2). Never use the products for the equipment listed in Paragraph (3).
 - Office electronics
 - Instrumentation and measuring equipment
 - Machine tools
 - Audiovisual equipment
 - Home appliances
 - Communication equipment other than for trunk lines

 - (2) These contemplating using the products covered herein for the following equipment which demands high reliability, should first contact a sales representative of the company and then accept responsibility for incorporating into the design fail-safe operation, redundancy, and other appropriate measures for ensuring reliability and safety of the equipment and the overall system.
 - Control and safety devices for airplanes, trains, automobiles, and other transportation equipment
 - Mainframe computers
 - traffic control systems
 - Gas leak detectors and automatic cutoff devices
 - Rescue and security equipment
 - Other safety devices and safety equipment, etc.

 - (3) Do not use the products covered herein for the following equipment which demands extremely high performance in terms of functionality, reliability, or accuracy
 - Aerospace equipment
 - Communications equipment for trunk lines
 - Control equipment for the nuclear power industry
 - Medical equipment related to life support, etc.

 - (4) Please direct all queries and comments regarding the interpretation of the above three Paragraphs to a sales representative of the company.

- Please direct all queries regarding the products covered herein to a sales representative of the company.

CONTENTS

	Page
1. General Description	2
2. Terminal Name	3
3. Terminal Connection	3
4. Block Diagram	4
5. Input/Output Circuit Type	5
6. Precautions	6
7. Absolute Maximum Ratings	6
8. Electrical Characteristics	7
9. Package and Packing Specificat	9

1. General Description

The Sharp IR3E3106 is an IC that generates gamma correction reference voltage for TFT LCD color monitors.

Features:

- Low power consumption. 9mW(TYP)
- Contains a regulator of high accuracy. $4.1V \pm 2.5\%$
- Output sink/source current. 1mA(MAX)

Not designed or rated as radiation hardened.

Package material:	Plastic
Chip material and wafer substrate type:	P type silicon
Number of pins and package type:	20-pin QFN
Process(Structure):	Bipolar

Applications

TFT LCD color monitors

2. Terminal Name

Pin No.	Term. Name	Description
1	SW	Input terminal for switching signal.
2	COM	Produce SW signal with the amplitude of 0~5V.
3	V0	Reference voltage output terminal for TFT LCD.
4	N.C.	No connection terminal.
5	V1	Reference voltage output terminal for TFT LCD.
6	N.C.	No connection terminal.
7	N.C.	No connection terminal.
8	GND	GND terminal.
9	N.C.	No connection terminal.
10	N.C.	No connection terminal.
11	V2	Reference voltage output terminal for TFT LCD.
12	V3	Reference voltage output terminal for TFT LCD.
13	V4	Reference voltage output terminal for TFT LCD.
14	VCC	Power supply terminal.
15	N.C.	No connection terminal.
16	VDD	Reference voltage output terminal.
17	N.C.	No connection terminal.
18	N.C.	No connection terminal.
19	N.C.	No connection terminal.
20	N.C.	No connection terminal.

3. Terminal connection

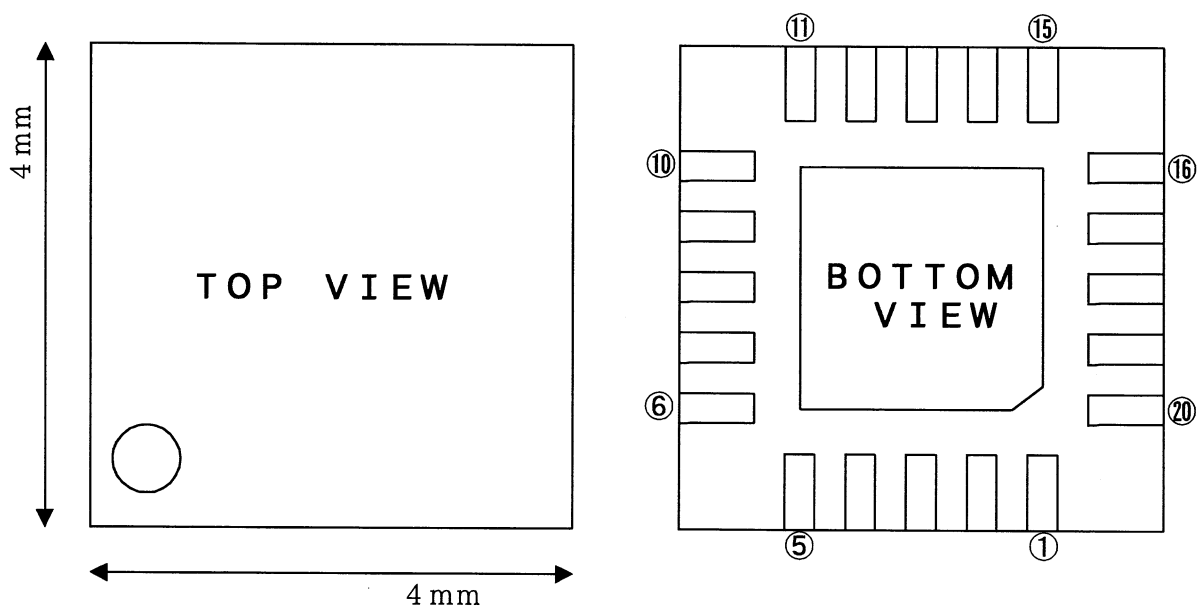

4. Block Diagram

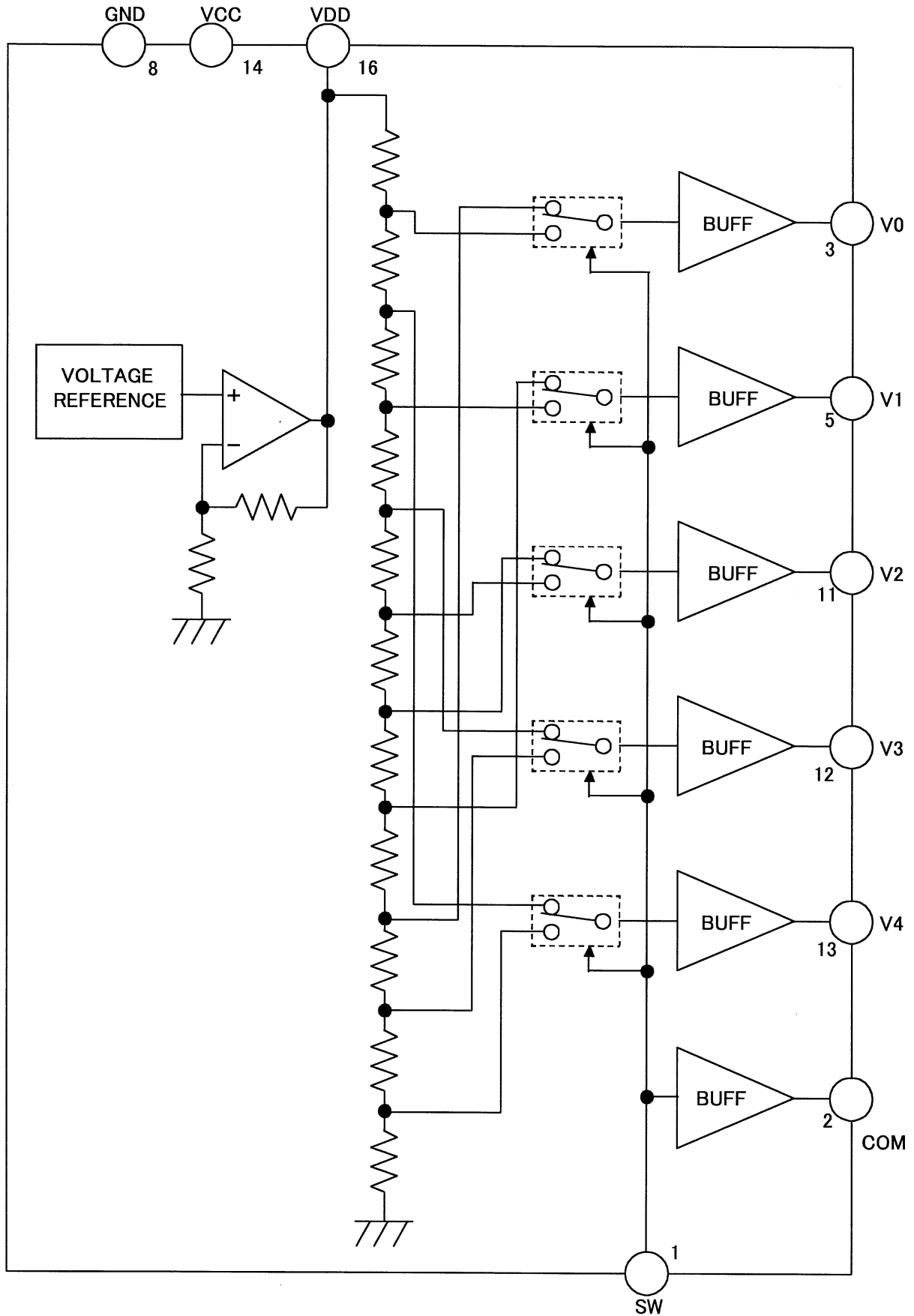

5. Input/Output Circuit Type (Vcc=5.0V)

No.	Symbol	Voltage	Circuit type	Discription
1	SW	0~5V		Input terminal for switching signal. LOW : input voltage $\leq 0.8V$ HIGH: input voltage $\geq 2.0V$
2	COM	0V or 5V		Produce SW signal with the amplitude of 0~5V.
3	V0	3.72V		Reference voltage output terminal for TFT LCD.
5	V1	or 0.52V		
12	V3	or 1.12V		
13	V4	or 3.32V or 0.52V or 4.02V		
11	V2	2.10V or 2.30V		Reference voltage output terminal for TFT LCD.
16	VDD	4.10V		Reference voltage output terminal. Connect a capacitor between GND.
8	GND	0V		GND terminal.
14	VCC	5V		Power supply terminal.

6. Precautions

i)GND terminal

Make sure that Pin 8 is connected to GND, and do not open it.

ii)Decoupling capacitor

Place the decoupling capacitor connected to Pin 14,16 to the IC pin as near as possible.

7. Absolute Maximum Ratings (Ta=25°C)

Parameter	Symbol	Condition	Rating	Unit
Supply voltage	VCC		7.0	V
Power dissipation	PD	Ta ≤ 25°C	350	mW
Derating ratio		Ta > 25°C	2.8	mW/°C
Operating temperature range	Topr		-25~75	°C
Storage temperature range	Tstg		-55~150	°C

Recommended operating conditions

Parameter	Symbol	Condition	Rating	Unit
Operating supply voltage range	VCC		4.6~5.0~5.5	V

8. Electrical Characteristics

Unless otherwise specified: VCC=5V, Ta=25°C, (SW)=5V

Num.	Parameter	Symbol	Conditions	Limits			Unit	
				MIN	TYP	MAX		
1	Current dissipation	ICC	(SW) = SG1		1.8	3.0	mA	
2	Reference voltage	VDD	VDD terminal output voltage	4.00	4.10	4.20	V	
3	Output line regulation	Δ VLI	Output regulation of V0~V9 at VCC=4.5V~5.5V, (SW)=0V and 5V		4	10	mV	
4	Output load regulation	Δ VLD1	(SW)=0V	sink current=1mA		+5	+15	mV
			and 5V(*1)	source current=1mA		-5	-15	mV
5	Output voltage	VA0	(SW)=5V	3.60	3.72	3.84	V	
		VA1	(SW)=5V	3.02	3.12	3.22	V	
		VA2	(SW)=5V	2.02	2.10	2.18	V	
		VA3	(SW)=5V	1.16	1.22	1.28	V	
		VA4	(SW)=5V	0.48	0.52	0.56	V	
		VB0	(SW)=0V	0.48	0.52	0.56	V	
		VB1	(SW)=0V	1.07	1.12	1.17	V	
		VB2	(SW)=0V	2.22	2.30	2.38	V	
		VB3	(SW)=0V	3.21	3.32	3.43	V	
6	COM output voltage	VCOMH	(SW)=5V	4.9			V	
		VCOML	(SW)=0V			0.1	V	
7	SW input "H" voltage	VIH		2.0			V	
8	SW input "L" voltage	VIL				0.8	V	
9	SW input "H" current	IIH	(SW)=5V	-0.1	0.0	0.1	μ A	
10	SW input "L" current	IIL	(SW)=0V	-1.0	-0.4		μ A	
11	Output rising time	tLH			3.0	6.0	μ s	
12	Output falling time	tHL			3.0	6.0	μ s	
13	COM output rising time	tLHC	1000pF load.		3.0	6.0	μ s	
14	COM output falling time	tHLC	1000pF load.		3.0	6.0	μ s	

(*1) Output regulation of V0~V4.

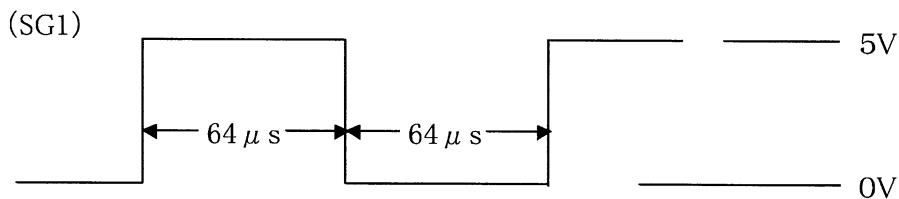

Test Circuit

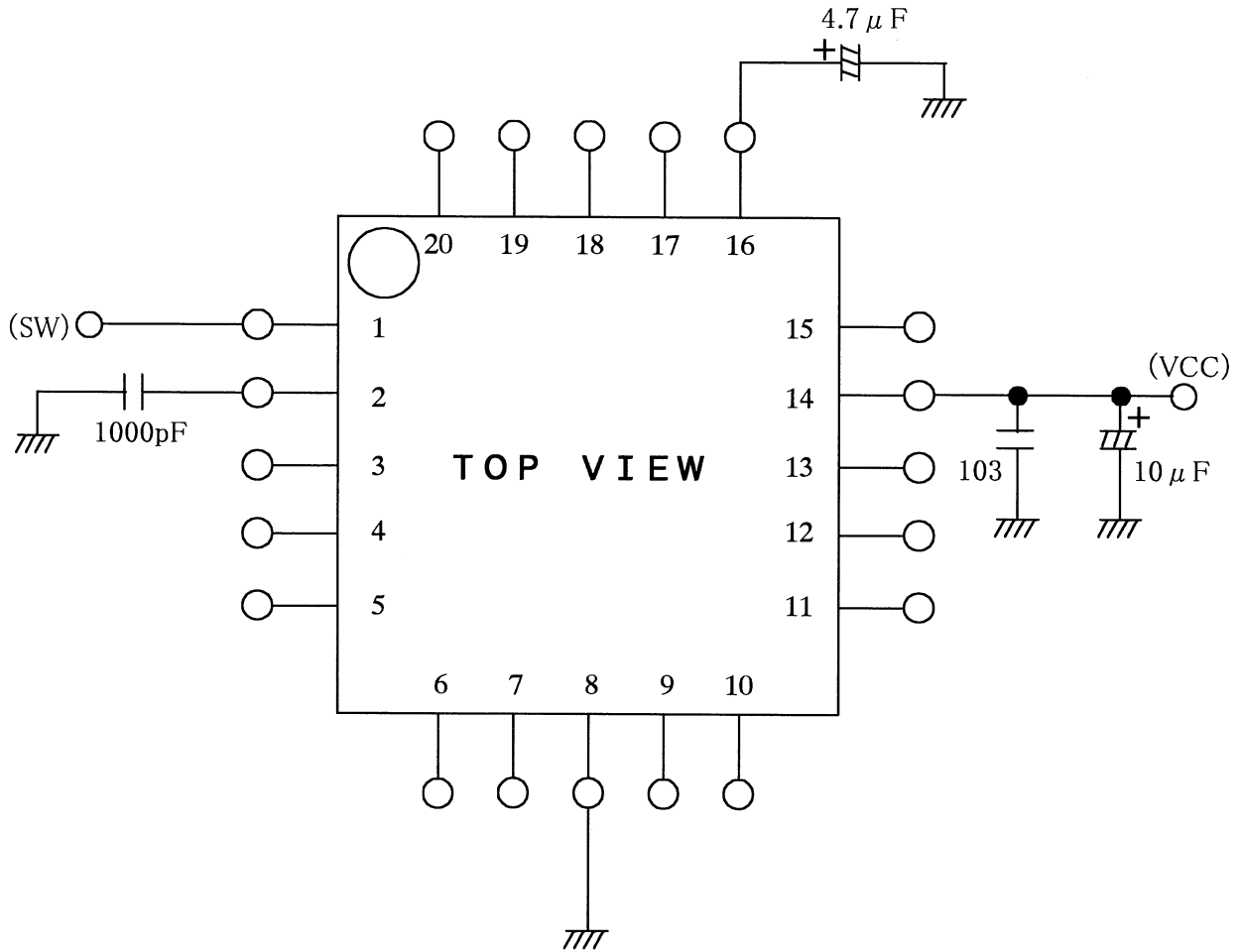

9 Package and packing specification

[Applicability]

This specification applies to IC package of the LEAD-FREE delivered as a standard specification.

1.Storage Conditions.

1-1.Storage conditions required before opening the dry packing.

- Normal temperature : 5~40°C
- Normal humidity : 80%(Relative humidity) max.
- "Humidity" means "Relative humidity"

1-2.Storage conditions required after opening the dry packing.

In order to prevent moisture absorption after opening, ensure the following storage conditions apply:

- (1) Storage conditions for one-time soldering. (Convection reflow^{*1}, IR/Convection reflow.^{*1})
 - Temperature : 5~25°C
 - Humidity : 60% max.
 - Period : 96 hours max. after opening.
- (2) Storage conditions for two-time soldering. (Convection reflow^{*1}, IR/Convection reflow.^{*1})
 - a. Storage conditions following opening and prior to performing the 1st reflow.
 - Temperature : 5~25°C
 - Humidity : 60% max.
 - Period : 96 hours max. after opening.
 - b. Storage conditions following completion of the 1st reflow and prior to performing the 2nd reflow.
 - Temperature : 5~25°C
 - Humidity : 60% max.
 - Period : 96 hours max. after completion of the 1st reflow.

^{*1}:Air or nitrogen environment.

1-3.Temporary storage after opening.

To re-store the devices before soldering, do so only once and use a dry box or place desiccant (with a blue humidity indicator) with the devices and perform dry packing again using heat-sealing.

The storage period, temperature and humidity must be as follows :

(1) Storage temperature and humidity.

※1 : External atmosphere temperature and humidity of the dry packing.

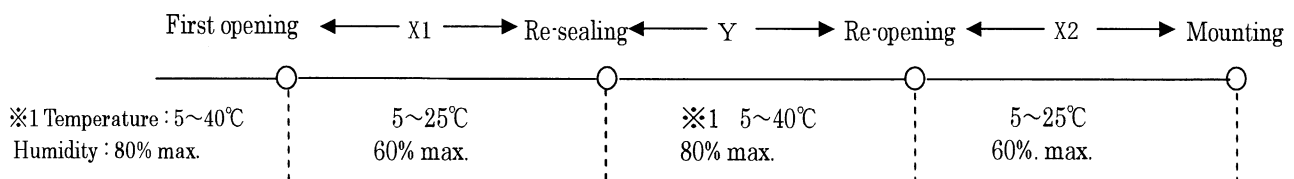

(2) Storage period.

- X1 + X2 : Refer to Section 1-2(1) and (2)a , depending on the mounting method.
- Y : Two weeks max.

2. Baking Condition.

(1) Situations requiring baking before mounting.

- Storage conditions exceed the limits specified in Section 1-2 or 1-3.
- Humidity indicator in the desiccant was already red (pink) when opened.
(Also for re-opening.)

(2) Recommended baking conditions.

- Baking temperature and period : $120 + 10 / - 0^{\circ}\text{C}$ for 2~3 hours.
- The above baking conditions do not apply since the embossed carrier tape are not heat-resistant . Replace the devices on heat-resistant carrier .

(3) Storage after baking.

- After baking, store the devices in the environment specified in Section 1-2 and mount immediately.

3. Surface mount conditions.

The following soldering condition are recommended to ensure device quality.

3-1.Soldering.

(1) Convection reflow or IR/Convection. (one-time soldering or two-time soldering in air or nitrogen environment)

- Temperature and period :

A) Peak temperature.	250°C max.
B) Heating temperature.	40 to 60 seconds as 220°C
C) Preheat temperature.	It is 150 to 200°C, and is 120±30 seconds
D) Temperature increase rate.	It is 1 to 3°C/seconds
- Measuring point : IC package surface.
- Temperature profile :

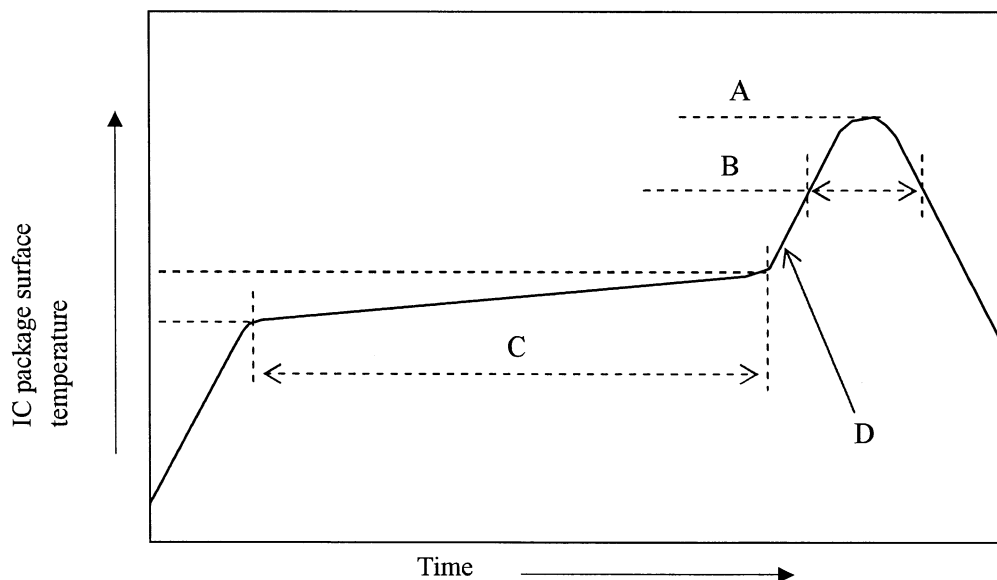

4. Condition for removal of residual flux.

- (1) Ultrasonic washing power : 25 watts / liter max.
- (2) Washing time : Total 1 minute max.
- (3) Solvent temperature : 15~40°C

5. Package outline specification.

Refer to the attached drawing.

(Plastic body dimensions do include burr of resin.)

The contents of LEAD-FREE TYPE application of the specifications. (*2)

6. Markings.

6-1. Marking details. (The information on the package should be given as follows.)

- (1) Product name : 3E314
- (2) Company name : SHARP
- (3) Date code

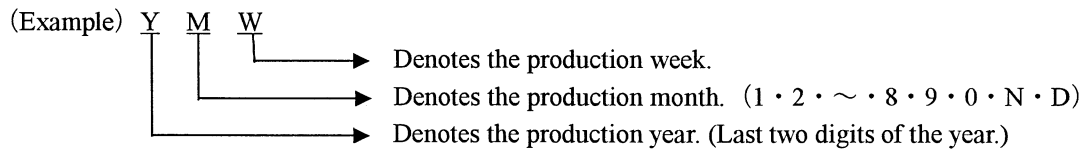

6-2. Marking layout.

The layout is shown in the attached drawing.

(However, this layout does not specify the size of the marking character and marking position.)

*2 The contents of LEAD-FREE TYPE application of the specifications.

LEAD FINISH or BALL TYPE	LEAD-FREE TYPE (Ni/Pd/Au)
DATE CODE	They are those with an underline under YMW
The word of " LEAD FREE" is printed on the packing label	Printed

(Note) It is those with an underline printing in a date code because of a LEAD-FREE type.

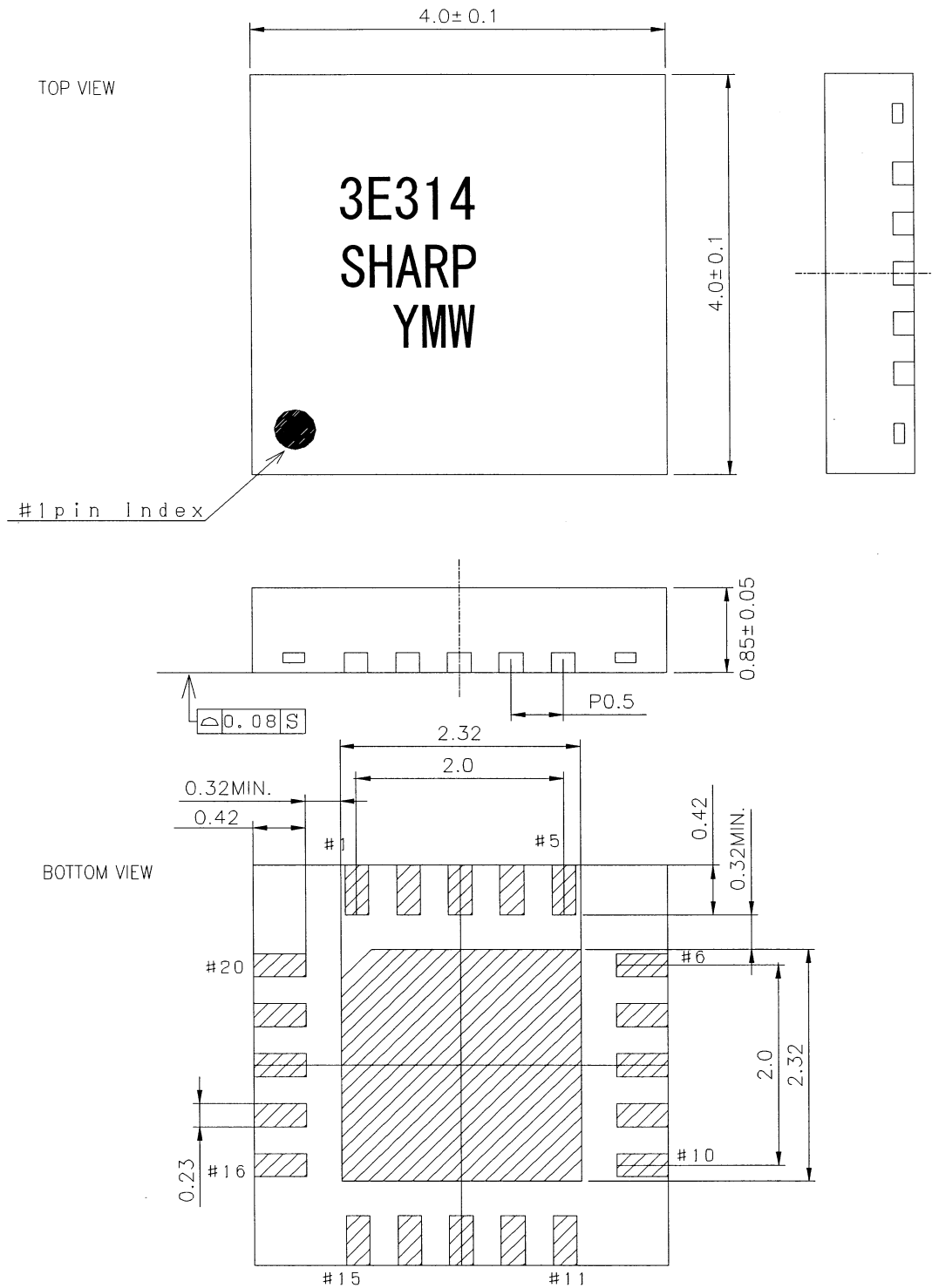

DIMENSIONAL TOLERANCE UNLESS OTHERWISE SPECIFIED ±0.10

HQFN020-P-0404-AA2268

LEAD TYPE	LEAD FINISH		LEAD MATERIAL	
	Ni/Pd/Au PLATING		Cu	
NAME	HQFN020-P-0404		NOTE : Plastic body dimensions do include burr of resin.	
DRAWING NO.	AA2268	UNIT		

7. Packing specifications (Embossed carrier tape specifications)

This standard applies to the embossed carrier tape specifications for ICs supplied by SHARP CORPORATION. SHARP's embossed carrier tape specifications are generally based on those described in JIS C 0806 (Japanese Industrial Standard) and EIA481A.

7-1. Tape structure

The embossed carrier tape is made of conductive plastic. The embossed portions of the carrier tape are filled with IC packages and a top covering tape is used to enclose them.

7-2. Taping reel and embossed carrier tape size

For the taping reel and embossed carrier tape sizes, refer to the attached drawing.

7-3. IC package enclosure direction in embossed carrier tape

The IC package enclosure direction in the embossed portion relative to the direction in which the tape is pulled is indicated by an index mark on the package (indicating the No. 1 pin) shown in the attached drawing.

7-4. Missing IC packages in embossed carrier tape

The number of missing IC packages in the embossed carrier tape per reel should not exceed Either 1 or 0.1 % of the total contained on the tape per reel, whichever is larger. There should never be more than two consecutive missing IC packages.

7-5. Tape joints

There is no joint in an embossed carrier tape.

7-6. Peeling strength of the top covering tape

Peeling strength must meet the following conditions.

- (1) Peeling angle at $165^{\circ} \sim 180^{\circ}$.
- (2) Peeling speed at 300mm/min .
- (3) Peeling strength at 0.2~0.7N (20~70gf) .

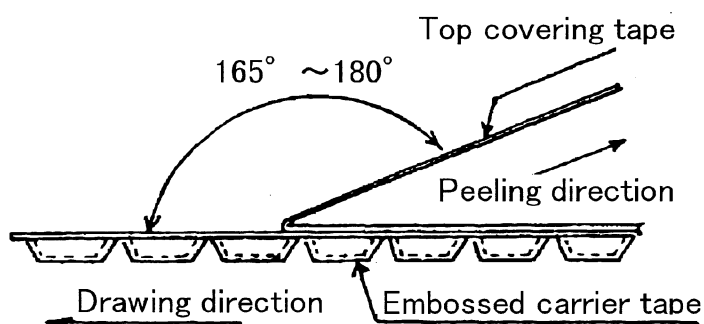

7-7. Packing

- (1) The top covering tape (leader side) at the leading edge of the embossed carrier tape, and the trailing edge of the embossed carrier tape, should both be held in place with paper adhesive tape at least 30 mm in length.
- (2) The leading and trailing edges of the embossed carrier tape should be left empty (with embossed portions not filled with IC packages) in the attached drawing.
- (3) The number of IC packages enclosed in the embossed carrier tape per reel should generally comply with the list given below.

Number of IC Packages/ Reel	Number of IC Packages/ Inner carton	Number of IC Packages/ Outer carton
2500 devices / Reel	2500 devices / Inner carton	12500 devices / Outer carton

7-8. Indications

The following should be indicated on the taping reel and the packing carton.

- Part Number (Product Name) • Storage Quantity • Packed date
- Manufacture's Name (SHARP)

Note : The IC taping direction is indicated by " EL " suffixed to the part number .
 EL : Equivalent to " L " of the JIS C 0806 standard..

7-9. Protection during transportation

The IC packages should have no deformation and deterioration of their electrical Characteristics resulting from transportation.

8. Precautions for use.

- (1) Opening must be done on an anti-ESD treated workbench.
 All workers must also have undergone anti-ESD treatment.
- (2) The devices should be mounted the devices within one year of the date of delivery.

EMBOSS TAPING TYPE (EL)

IC TAPING DIRECTION

THE DRAWING DIRECTION OF TAPE →

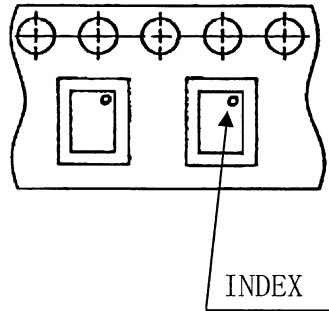

LEADER SIDE AND END SIDE OF TAPE

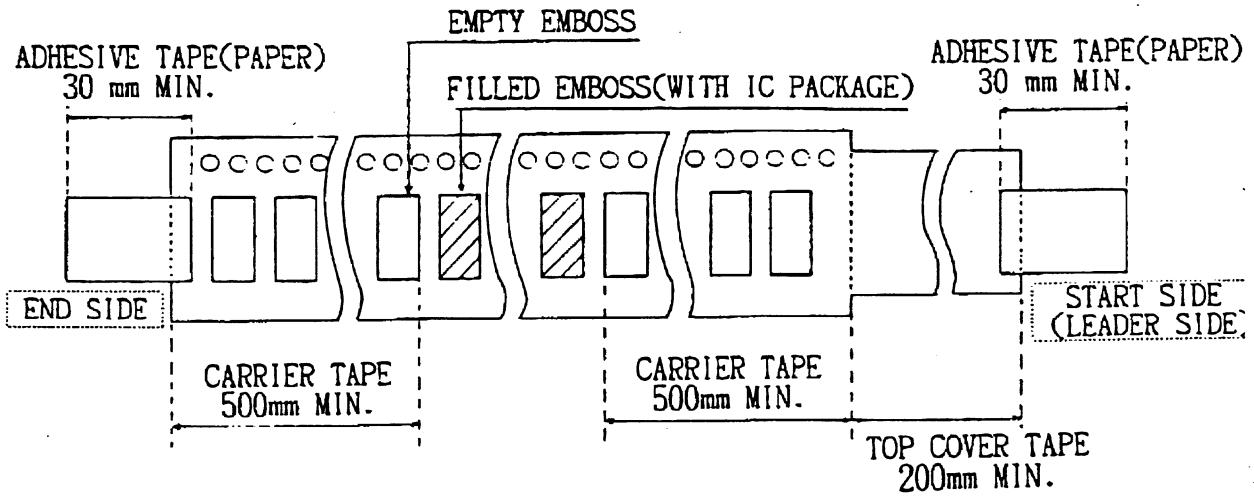

名称 NAME	Emboss taping type(EL)		備考 NOTE
DRAWING NO.	CV522	単位 UNIT	mm

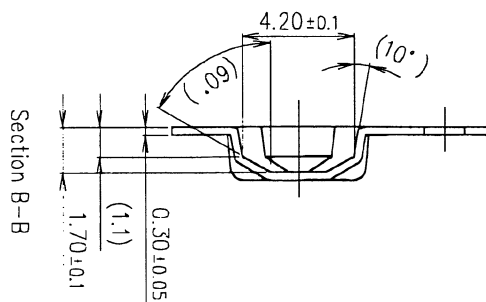
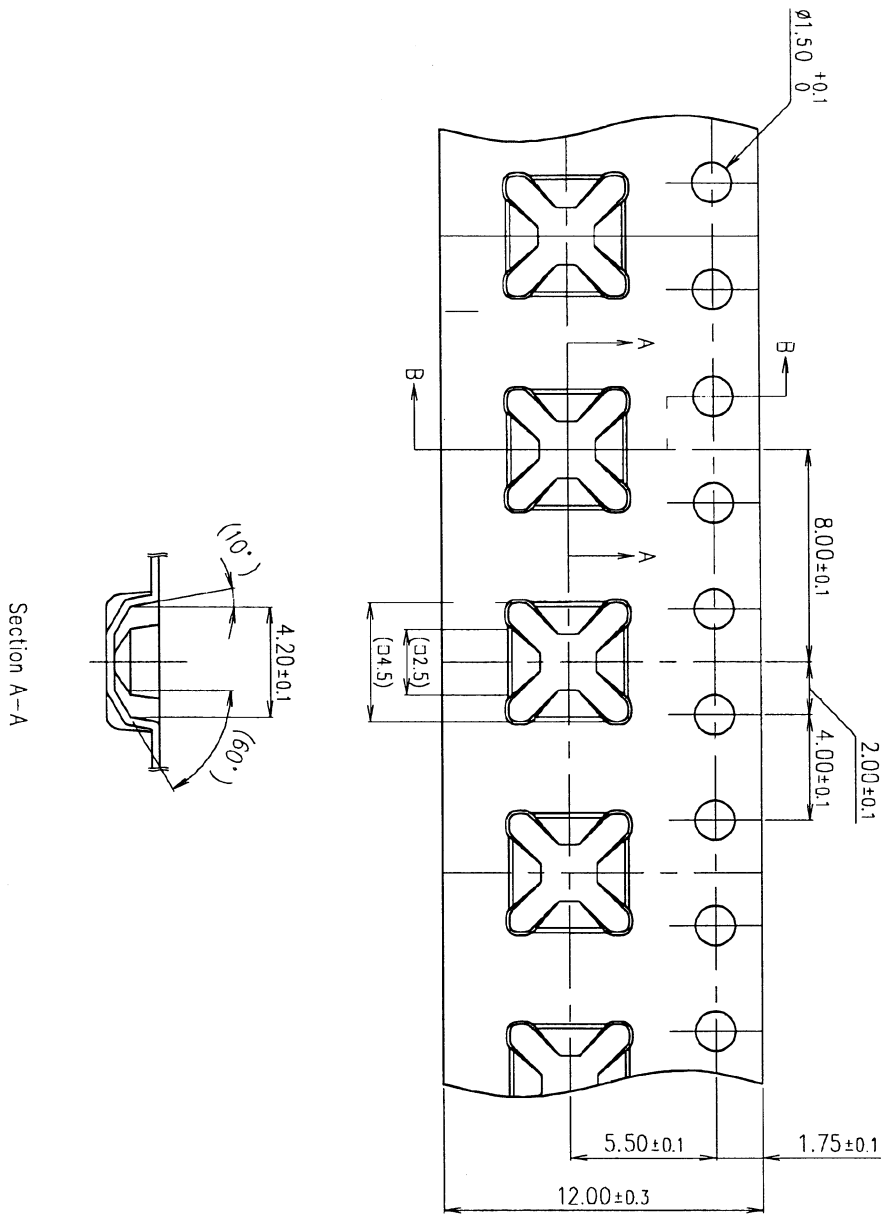

Note
 1) The radius (R) is 0.3mm max
 2) Cumulative tolerance of 10 pitches of the sprocket hole is ± 0.2 mm

名称 NAME	EC20-0404VQNSS		備考 NOTE
DRAWING NO.	CV883	単位 UNIT	mm

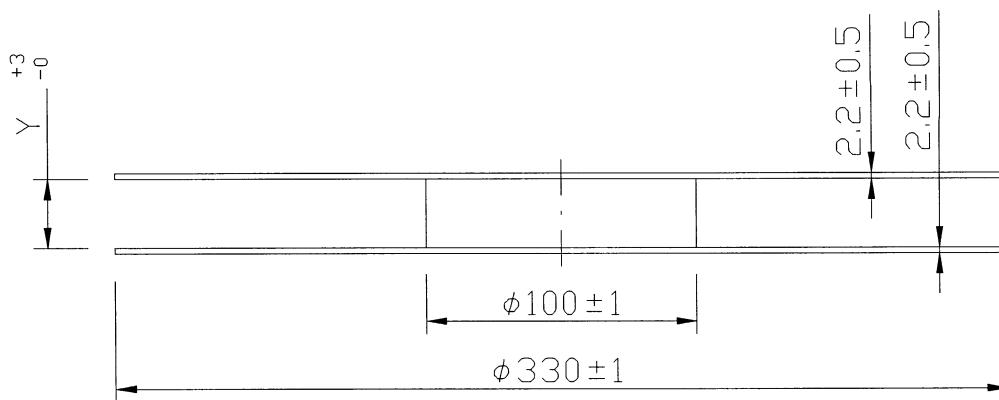
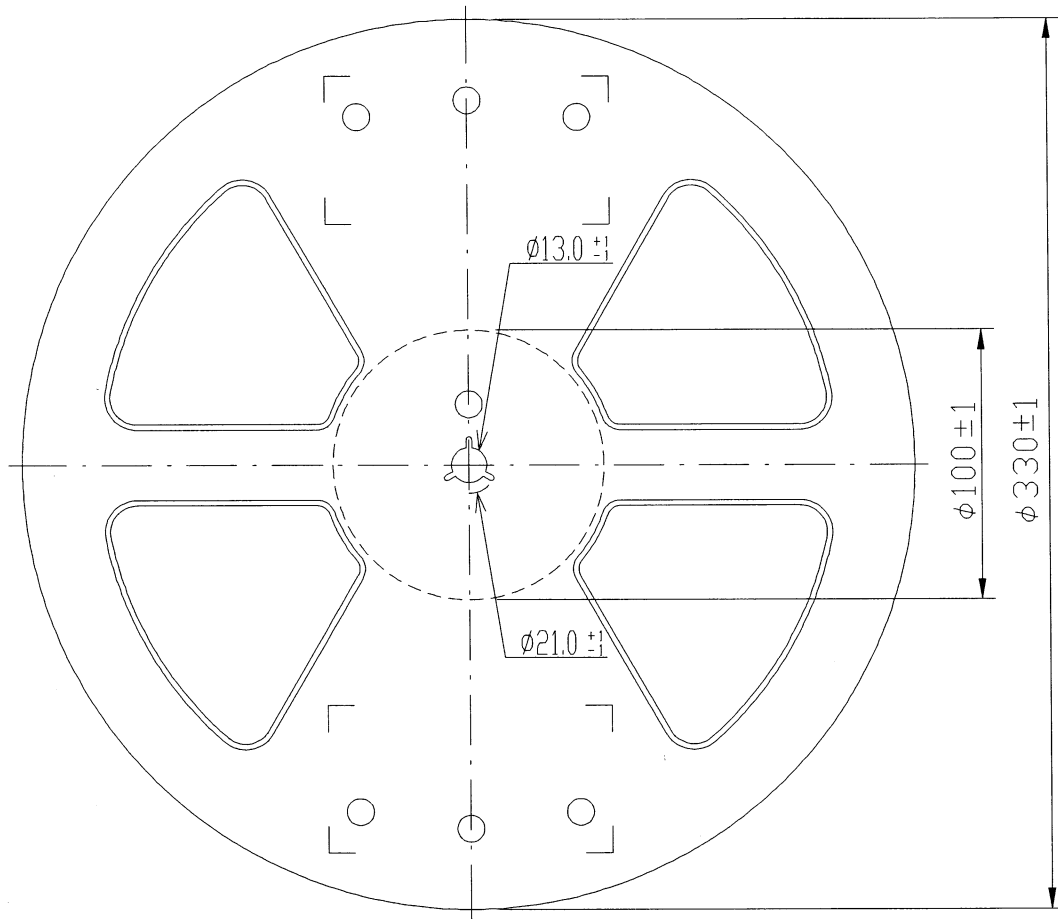

SIZE	Y	SIZE	Y
8mm	9.5	32mm	33.5
12mm	13.5	44mm	45.5
16mm	17.5	56mm	57.5
24mm	25.5		

名称 NAME	Reel for embossed carrier tape		
DRAWING NO.	CV755	単位 UNIT	mm

備考
NOTE

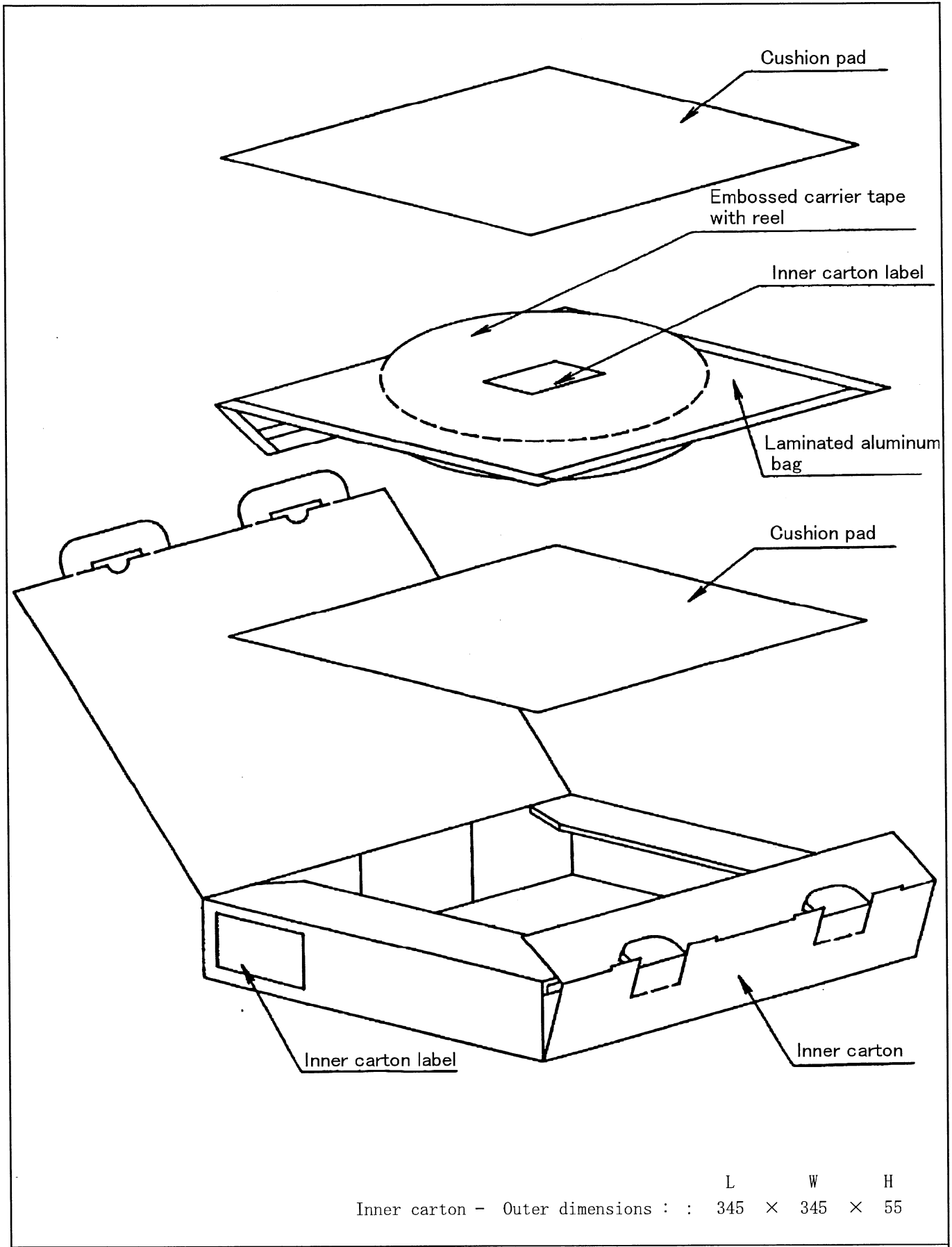

名称 NAME	Packing specifications 《1》		備考 NOTE
DRAWING NO.	CV428	単位 UNIT	mm

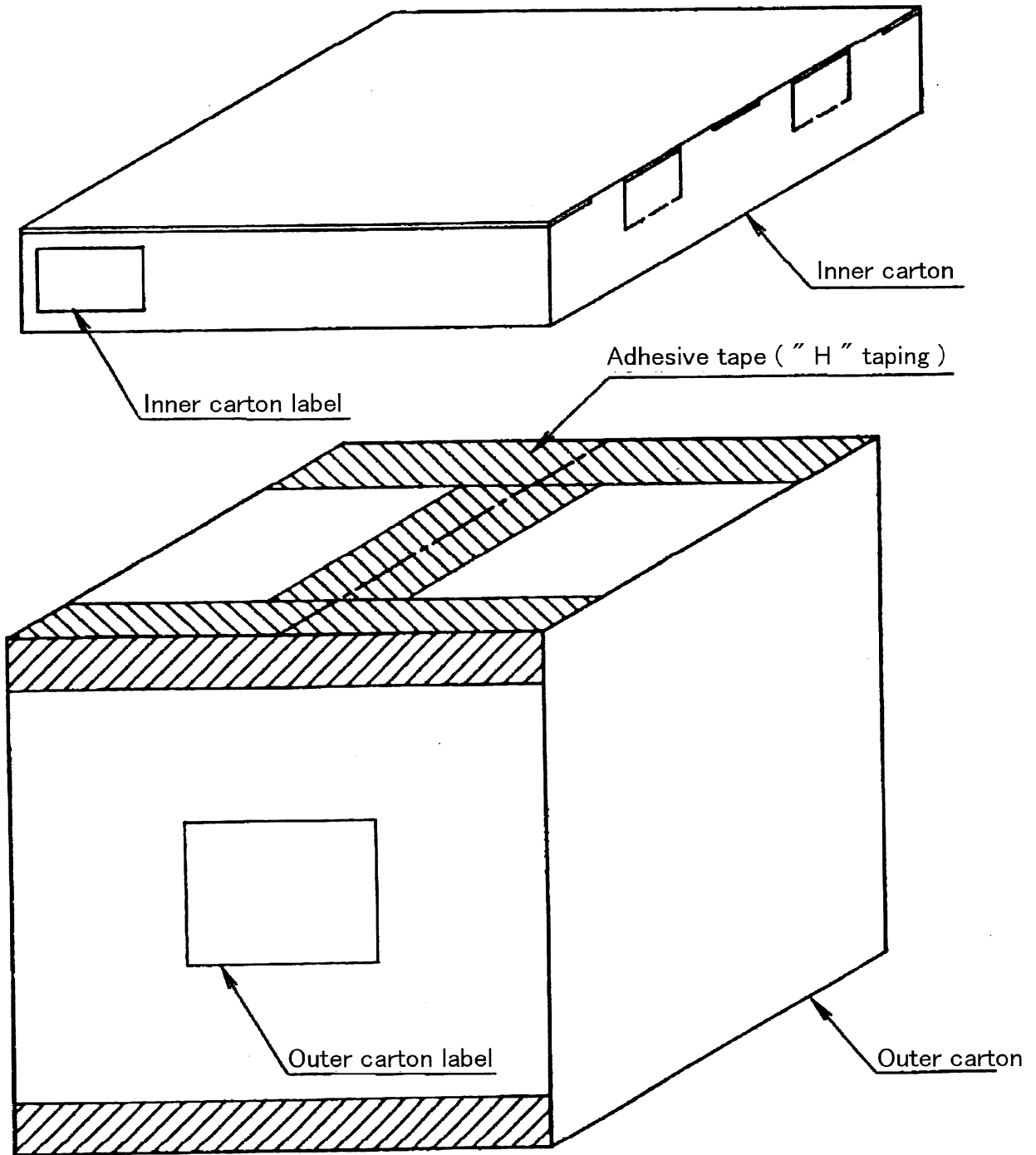

L W H

Inner carton - Outer dimensions : 345 × 345 × 55

Outer carton - Outer dimensions : 365 × 315 × 385

名称 NAME	Packing specifications 《2》	備考 出荷数量が端数の場合、本仕様と異なることがあります。 NOTE There is a possibility different from this specification when the number of shipments is fractions.
DRAWING NO.	BJ426	単位 UNIT mm

(Note) The <LEAD-FREE> display shows a lead-free article.

Inner carton label

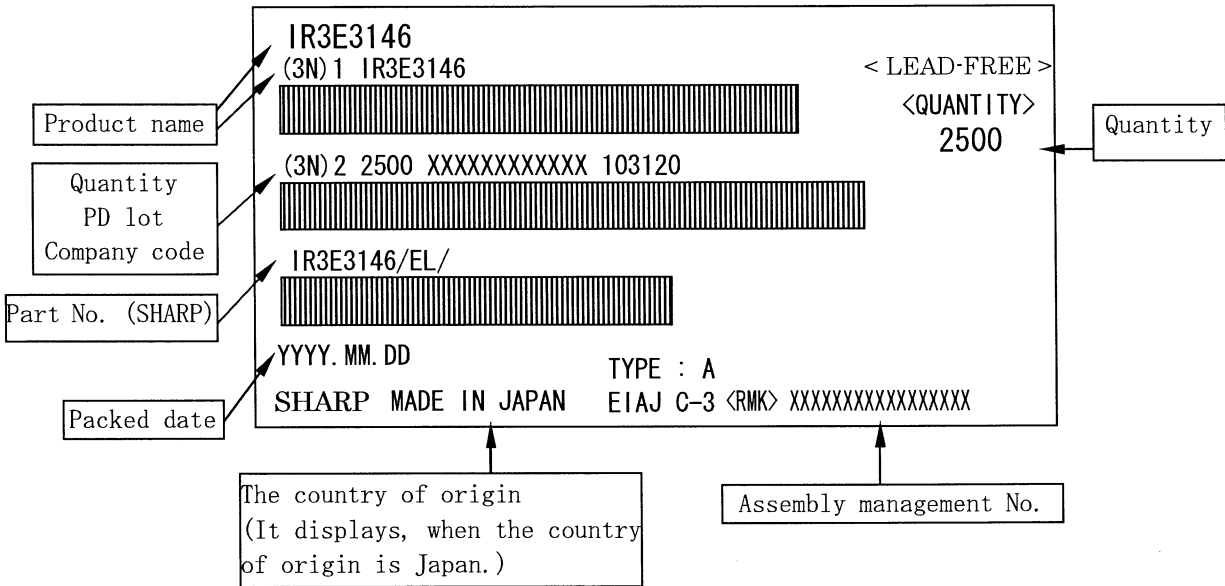

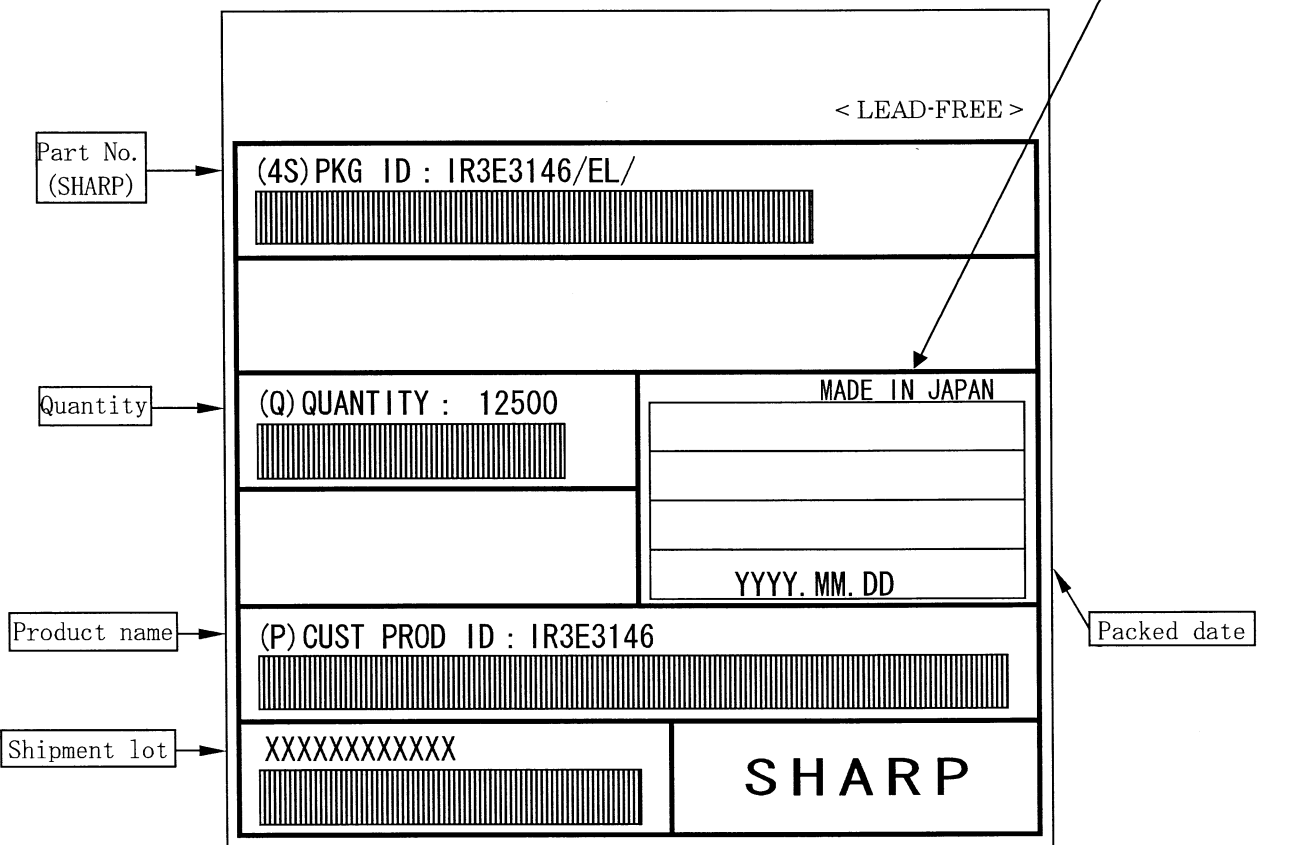

Outer carton label







(Former) EIAJ B Standard conforming

Looking for pricing, stock, or lifecycle information?

Click below to explore more details on WIN SOURCE:

-  [View IR3E3146 on WIN SOURCE](#)
-  [Sharp Microelectronics](#) Information

Optimize Your Supply Chain with WIN SOURCE Solutions

-  Global Sourcing Solution
-  Obsolete Management
-  Cost Control Management
-  Shortage Management
-  Alternative Solution
-  Excess Inventory Management