



**THE DATASHEET OF
BFC280823279**



Ø 5 mm Film Dielectric Trimmers



FEATURES

- Housing diameter 5 mm
- Top and bottom or top adjustment
- Round head
- Mounting: radial
- Material categorization: for definitions of compliance please see www.vishay.com/doc?99912

RoHS
COMPLIANT

APPLICATIONS

- Impedance matching circuits
- RF
- Medical
- For consumer and industrial equipment

QUICK REFERENCE DATA		
Rated DC voltage		150 V _{DC}
Test DC voltage for 1 min		300 V _{DC}
Allowed maximum AC voltage		15 V _{AC}
Maximum contact resistance		10 mΩ
Minimum insulation resistance		10 000 MΩ
Category temperature range	PP	-40 °C to +70 °C
	PTFE	-40 °C to +85 °C
Climatic category (IEC 60068)	PP	40/070/21
	PTFE	40/085/21
Minimum storage temperature		-55 °C
Related specification		IEC 60418-1 and 4
Effective angle of rotation		180° (rotation in 180° only, see "Life of Trimmer")
Operating torque	C _{max.} < 20 pF	1 mNm to 15 mNm
	C _{max.} ≥ 20 pF	1 mNm to 25 mNm
Maximum axial thrust		2 N
Capacitance range (C _{min.} / C _{max.})		0.35 pF / 1.5 pF to 4 pF / 27 pF
Life of trimmer		Maximum 10 cycles: rotation in 180° only (the electrical and mechanical performance is not guaranteed if rotated beyond 10 cycles)
Quality level		Sampling and data evaluation for quality level in accordance with "MIL-STD-105D" and "IEC 60410": < 0.15 % major defects < 0.65 % minor defects Each capacitor is tested for minimum C _{max.} and is also subjected to the full test voltage.

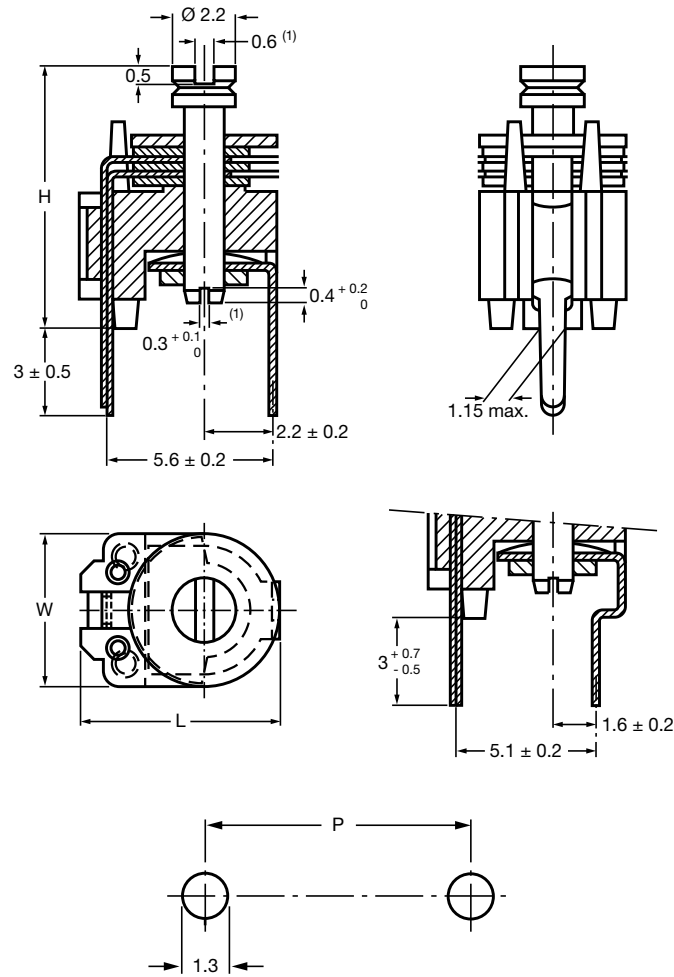
DIMENSIONS in millimeters

Hole pattern

Trimmers BFC2 808 series, with round head

CAPACITANCE AND RELEVANT PHYSICAL DIMENSIONS			
$C_{min.} / C_{max.}$ (pF)	$H_{max.}$ (mm)	$W_{max.}$ (mm)	$L_{max.}$ (mm)
0.35 / 1.5	7.0	5.5	7.3
1.5 / 5	7.0	5.5	7.3
3 / 10	7.0	5.5	7.3
3 / 15	8.8	5.5	7.3
4 / 20	8.8	5.5	7.3
4 / 27	9.0	6.2	7.8



MOUNTING

The trimmer has a lead pitch of 5.08 mm or 5.6 mm and can be mounted on printed-circuit boards with a minimum hole diameter of 1.25 mm.

PACKAGING

Bulk packaged in cardboard boxes lined with expanded plastic, 1000 units per box.

ORDERING INFORMATION			
C _{min.} / C _{max.} (pF)	CATALOG NUMBER BFC2 808		
	TOP AND BOTTOM ADJUSTMENT (P = 5.6 mm)	TOP ADJUSTMENT ONLY (P = 5.6 mm)	TOP ADJUSTMENT ONLY (P = 5.08 mm)
POLYTETRAFLUORETHYLENE			
0.35 / 1.5	22158	-	-
POLYPROPYLENE			
1.2 / 5	-	24508	-
1.5 / 5	23508	-	20508
1.5 / 7	-	24708	-
3 / 10	23109	-	20109
3 / 15	23159	-	20159
4 / 20	23209	-	20209
4 / 27	23279	-	20279

ELECTRICAL DATA							
GUARANTEED MAX. C _{min.} / MIN. C _{max.} AT 200 kHz (pF)	tan δ AT C _{max.} x 10 ⁻⁴		TEMP. COEFF. (1) (10 ⁻⁶ /K)	MIN. f _{res} AT C _{max.} (MHz)	COLOR OF BASE	SMALLEST PACKAGING QUANTITY	CATALOG NUMBER BFC2
	1 MHz	100 MHz					
0.35 / 1.5	≤ 10	-	-450 ± 550	-	-	1000 808 22158
1.2 / 5	≤ 10	-	-200 ± 550	-	Grey	1000 808 24508
1.5 / 5	≤ 10	≤ 25	-200 ± 550	700	Grey	1000 808 20508
1.5 / 7	≤ 10	-	-50 ± 550	-	Grey	1000 808 23508
3 / 10	≤ 10	≤ 25	-250 ± 550	500	Yellow	1000 808 24708
3 / 15	≤ 10	≤ 25	-250 ± 550	400	Blue	1000 808 20109
4 / 20	≤ 10	≤ 25	-250 ± 400	300	Green	1000 808 23109
4 / 27	≤ 10	≤ 25	-250 ± 400	300	Red	1000 808 20159
						 808 23159
						 808 20209
						 808 23209
						 808 20279
						 808 23279

Note

(1) C: 60 % to 80 % of C_{max.}; T_{amb.}: from +20 °C to +70 °C

SOLDERING CONDITIONS

For general soldering conditions and wave soldering profile, we refer to the application note "Soldering Guidelines for Film Capacitors": www.vishay.com/doc?28171

TEST PROCEDURES AND REQUIREMENTS				
IEC 60418-1 CLAUSE	IEC 60068 TEST METHOD	TEST	PROCEDURE	REQUIREMENTS
4.2		Method of mounting	Method A	
14		Capacitance drift	After TC measurement	ΔC/C: ≤ 3 % for C _{max.} ≤ 10 pF ΔC/C: ≤ 2 % for C _{max.} > 10 pF
19		Thrust	Axial thrust of 2 N	ΔC/C: ≤ 0.4 %
21		Robustness of terminations:		
21.1	Ua	Tensile	1 N	No damage
21.2	Ub	Bending	1 cycle	No damage



TEST PROCEDURES AND REQUIREMENTS				
IEC 60418-1 CLAUSE	IEC 60068 TEST METHOD	TEST	PROCEDURE	REQUIREMENTS
22	Na	Rapid change of temperature	1 cycle; 0.5 h at lower and 0.5 h at upper category temperature	$\Delta C/C: \leq 2.5 \%$
23	T	Soldering:		
	Ta	Solderability	Solder bath immersion 3 mm; 235 °C; 2 s	Good wetting; no mechanical damage
	Tb	Resistance to heat	Solder bath: 260 °C; 10 s	No mechanical damage
24	Eb	Impact bump	4000 ± 10 bumps; 40 g; 6 ms	$\Delta C/C: \leq 1 \%$; no mechanical damage
25	Fc	Vibration	Frequency 10 Hz to 55 Hz; amplitude 0.75 mm; 1.5 h	$\Delta C/C: \leq 1 \%$; no mechanical damage
26		Climatic sequence:		$\Delta C/C: \leq 4 \%$
26.1	B	Dry heat	16 h at upper category temperature	$\tan \delta$ or PP and PTFE foil: $\leq 15 \times 10^{-4}$ $\tan \delta$ for PC foil: $\leq 80 \times 10^{-4}$ $R_{ins.}: \geq 10\,000\,M\Omega$ Rotor contact R: $\leq 10\,m\Omega$
26.2	D	Damp heat accelerated, first cycle	1 cycle; 24 h; +40 °C; 95 % to 100 % RH	Voltage proof: 300 V for 1 min
26.3	Aa	Cold	16 h; -40 °C	Visual examination: no mechanical damage
26.5		Damp heat accelerated, remaining cycles	1 cycle; 24 h; +40 °C; 95 % to 100 % RH	Operating torque: 1 mNm to 20 mNm for $C_{max.} < 20\,pF$; 1 mNm to 30 mNm for $C_{max.} \geq 20\,pF$
27	Ca	Damp heat steady state	21 days; +40 °C; 90 % to 95 % RH	$\Delta C/C: \leq 3 \%$ $\tan \delta$ for PP and PTFE foil: $\leq 15 \times 10^{-4}$; $\tan \delta$ for PC foil: $\leq 80 \times 10^{-4}$ $R_{ins.}: \geq 10\,000\,M\Omega$; Rotor contact R: $\leq 10\,m\Omega$ Voltage proof: 300 V for 1 min Visual examination: no mechanical damage Operating torque: 1 mNm to 20 mNm for $C_{max.} < 20\,pF$; 1 mNm to 30 mNm for $C_{max.} \geq 20\,pF$
29		Mechanical endurance	10 cycles Maximum 10 cycles: rotation in 180° only. (The electrical and mechanical performance is not guaranteed if rotated beyond 10 cycles)	$\Delta C/C: \leq 3 \%$ $\Delta C/C$ after axial thrust: $\leq 0.3 \%$; rotor contact R: $\leq 10\,m\Omega$ Voltage proof: 300 V for 1 min Visual examination: no mechanical damage Operating torque: 0.5 mNm to 22.5 mNm for $C_{max.} < 20\,pF$; 0.5 mNm to 30 mNm for $C_{max.} \geq 20\,pF$



Disclaimer

ALL PRODUCT, PRODUCT SPECIFICATIONS AND DATA ARE SUBJECT TO CHANGE WITHOUT NOTICE TO IMPROVE RELIABILITY, FUNCTION OR DESIGN OR OTHERWISE.

Vishay Intertechnology, Inc., its affiliates, agents, and employees, and all persons acting on its or their behalf (collectively, "Vishay"), disclaim any and all liability for any errors, inaccuracies or incompleteness contained in any datasheet or in any other disclosure relating to any product.

Vishay makes no warranty, representation or guarantee regarding the suitability of the products for any particular purpose or the continuing production of any product. To the maximum extent permitted by applicable law, Vishay disclaims (i) any and all liability arising out of the application or use of any product, (ii) any and all liability, including without limitation special, consequential or incidental damages, and (iii) any and all implied warranties, including warranties of fitness for particular purpose, non-infringement and merchantability.

Statements regarding the suitability of products for certain types of applications are based on Vishay's knowledge of typical requirements that are often placed on Vishay products in generic applications. Such statements are not binding statements about the suitability of products for a particular application. It is the customer's responsibility to validate that a particular product with the properties described in the product specification is suitable for use in a particular application. Parameters provided in datasheets and / or specifications may vary in different applications and performance may vary over time. All operating parameters, including typical parameters, must be validated for each customer application by the customer's technical experts. Product specifications do not expand or otherwise modify Vishay's terms and conditions of purchase, including but not limited to the warranty expressed therein.

Hyperlinks included in this datasheet may direct users to third-party websites. These links are provided as a convenience and for informational purposes only. Inclusion of these hyperlinks does not constitute an endorsement or an approval by Vishay of any of the products, services or opinions of the corporation, organization or individual associated with the third-party website. Vishay disclaims any and all liability and bears no responsibility for the accuracy, legality or content of the third-party website or for that of subsequent links.

Vishay products are not designed for use in life-saving or life-sustaining applications or any application in which the failure of the Vishay product could result in personal injury or death unless specifically qualified in writing by Vishay. Customers using or selling Vishay products not expressly indicated for use in such applications do so at their own risk. Please contact authorized Vishay personnel to obtain written terms and conditions regarding products designed for such applications.

No license, express or implied, by estoppel or otherwise, to any intellectual property rights is granted by this document or by any conduct of Vishay. Product names and markings noted herein may be trademarks of their respective owners.

Looking for pricing, stock, or lifecycle information?

Click below to explore more details on WIN SOURCE:

 [View BFC280823279 on WIN SOURCE](#)

 [Vishay Information](#)

Optimize Your Supply Chain with WIN SOURCE Solutions

-  Global Sourcing Solution
-  Obsolete Management
-  Cost Control Management
-  Shortage Management
-  Alternative Solution
-  Excess Inventory Management