



# THE DATASHEET OF IR2085S



### Features

- Simple primary side control solution to enable half-bridge DC-Bus Converters for 48V distributed systems with reduced component count and board space
- Integrated 50% duty cycle oscillator & half-bridge driver IC in a single SO-8 package
- Programmable switching frequency with up to 500kHz max per channel
- +/- 1A drive current capability optimized for low charge MOSFETs
- Adjustable dead-time 50ns – 200ns
- Floating channel designed for bootstrap operation up to +100Vdc
- High and low side pulse width matching to +/- 25ns
- Adjustable overcurrent protection
- Undervoltage lockout and internal soft start
- Also available Leadfree

### Product Summary

Topology	Half-Bridge
$V_{\text{OFFSET}}$	$\leq 100 \text{ V}$
$I_{\text{O+}} \& I_{\text{O-}}$ (typical)	1.0A & 1.0A
$f_{\text{OSC}}$ (max)	500kHz
Deadtime	50ns – 200ns
HO/LO Pulse Matching	+/- 25ns

### Package



### Description

The IR2085S is a self-oscillating half-bridge driver IC with 50% duty cycle ideally suited for 36V – 75V half-bridge DC-bus converters.

This product is also suitable for push-pull converters without restriction on input voltage.

Each channel frequency is equal to  $f_{\text{OSC}}$ , which can be set by selecting  $R_T$  &  $C_T$ , where  $f_{\text{OSC}} = 1/(2 \cdot R_T \cdot C_T)$ . Dead-time can be controlled through proper selection of  $C_T$  and can range from 50ns to 200ns. Internal soft-start increases the pulse width during power up and maintains pulse width matching for the high and low outputs throughout the start up cycle. The IR2085S initiates a soft start at power up and after every overcurrent condition. Undervoltage lockout prevents operation if  $V_{\text{CC}}$  is less than 7.5V.

### Typical Connection Diagram

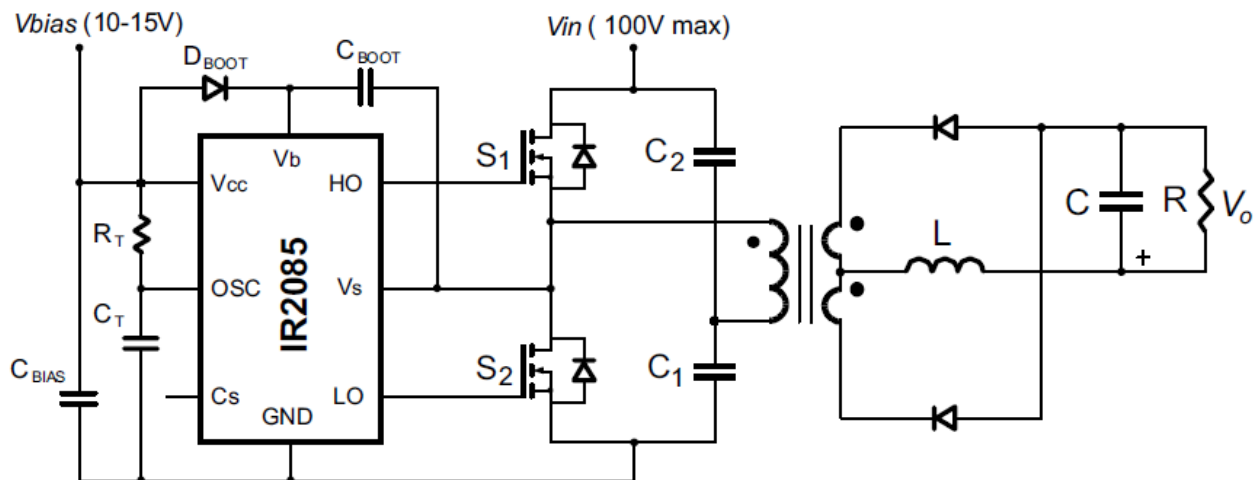

## Absolute Maximum Ratings

Absolute maximum ratings indicate sustained limits beyond which damage to the device may occur. All voltage parameters are absolute voltages referenced to COM. All currents are defined positive into any lead. The thermal resistance and power dissipation ratings are measured under board mounted and still air conditions.

Symbol	Definition	Min.	Max.	Units
V <sub>b</sub>	High side floating supply voltage	-0.3	150	V
V <sub>CC</sub>	Low side supply voltage	—	25	
V <sub>S</sub>	High side floating supply offset voltage	V <sub>b</sub> - 25	V <sub>b</sub> + 0.3	
V <sub>HO</sub>	High side floating output voltage	V <sub>b</sub> - 0.3	V <sub>b</sub> + 0.3	
V <sub>LO</sub>	Low side output voltage	-0.3	V <sub>CC</sub> + 0.3	
OSC	OSC pin voltage	-0.3	V <sub>CC</sub> + 0.3	
V <sub>CS</sub>	Cs pin voltage	-0.3	V <sub>CC</sub> + 0.3	
dV <sub>S</sub> /dt	Allowable offset voltage slew rate	-50	+50	V/ns
I <sub>CC</sub>	Supply current	—	20	mA
P <sub>D</sub>	Package power dissipation	—	1.0	W
R <sub>thJA</sub>	Thermal resistance, junction to ambient	—	200	°C/W
T <sub>J</sub>	Junction temperature	-55	150	°C
T <sub>S</sub>	Storage temperature	-55	150	
T <sub>L</sub>	Lead temperature (soldering, 10 seconds)	—	300	

## Recommended Operating Conditions

For proper operation the device should be used within the recommended conditions.

Symbol	Definition	Min.	Max.	Units
V <sub>b</sub>	High side floating supply voltage	V <sub>dd</sub> - 0.7	15	V <sub>dc</sub>
V <sub>S</sub>	Steady state high side floating supply offset voltage	-5	100	
V <sub>CC</sub>	Supply voltage	10	15	
I <sub>CC</sub>	Supply current (Note 2)	—	5	mA
R <sub>T</sub>	Timing resistor	10	100	KΩ
C <sub>T</sub>	Timing capacitor	47	1000	pF
fosc(max)	Operating frequency (per channel)	—	500	KHz
T <sub>J</sub>	Junction temperature	-40	125	°C

Note1: Care should be taken to avoid output switching conditions where the V<sub>S</sub> node flies inductively below ground by more than 5V.

### Dynamic Electrical Characteristics

$V_{BIAS} (V_{CC}, V_{BS}) = 12V$ ,  $C_{LOAD} = 1000 \text{ pF}$ , and  $T_A = 25^\circ\text{C}$  unless otherwise specified.

Symbol	Definition	Min.	Typ.	Max.	Units	Test Conditions
$t_r$	Turn-on rise time	—	40	60	nsec	$V_S = 0V$
$t_f$	Turn-off fall time	—	20	30		
$f_{osc}$	Per channel output frequency	500	—	—	KHz	$C_T = 100\text{pF}$ , $R_T = 10\text{Kohm}$
$t_{dt}$	High/low output dead time	50	—	—		
$t_{dcs}$	Overcurrent shut down delay	—	200	—	nsec	pulse on CS
PM	High/low pulse width mismatch	-25	—	25		$V_S = 0V \sim 100V$

### Static Electrical Characteristics

$V_{BIAS} (V_{CC}, V_{BS}) = 12V$ ,  $C_{LOAD} = 1000 \text{ pF}$  and  $T_A = 25^\circ\text{C}$  unless otherwise specified.

Symbol	Definition	Min.	Typ.	Max.	Units	Test Conditions
$V_{OH}$	High level output voltage, ( $V_{BIAS} - V_O$ )	—	—	1.5	V	
$V_{OL}$	Low level output voltage	—	—	0.1		
$I_{leak}$	Offset supply leakage current	—	—	50	$\mu\text{A}$	
$I_{QBS}$	Quiescent $V_{BS}$ supply current	—	—	150		
$I_{QCC}$	Quiescent $V_{CC}$ supply current	—	—	1.5	$\text{mA}$	
$V_{CS+}$	Overcurrent shutdown threshold	250	300	350	$\text{mV}$	
$V_{CS-}$	Overcurrent shutdown threshold	150	200	250	$\text{mV}$	
$U_{VCC+}$	Undervoltage positive going threshold	6.8	7.3	7.8	V	
$U_{VCC-}$	Undervoltage negative going threshold	6.3	6.8	7.3		
$U_{VBS+}$	High side undervoltage positive going threshold	6.8	7.3	7.8		
$U_{VBS-}$	High side undervoltage negative going threshold	6.3	6.8	7.3		
$I_{O+}$	Output high short circuit current	—	1.0	—	A	
$I_{O-}$	Output low short circuit current	—	1.0	—		

# IR2085S & (PbF)

## Functional Block Diagrams

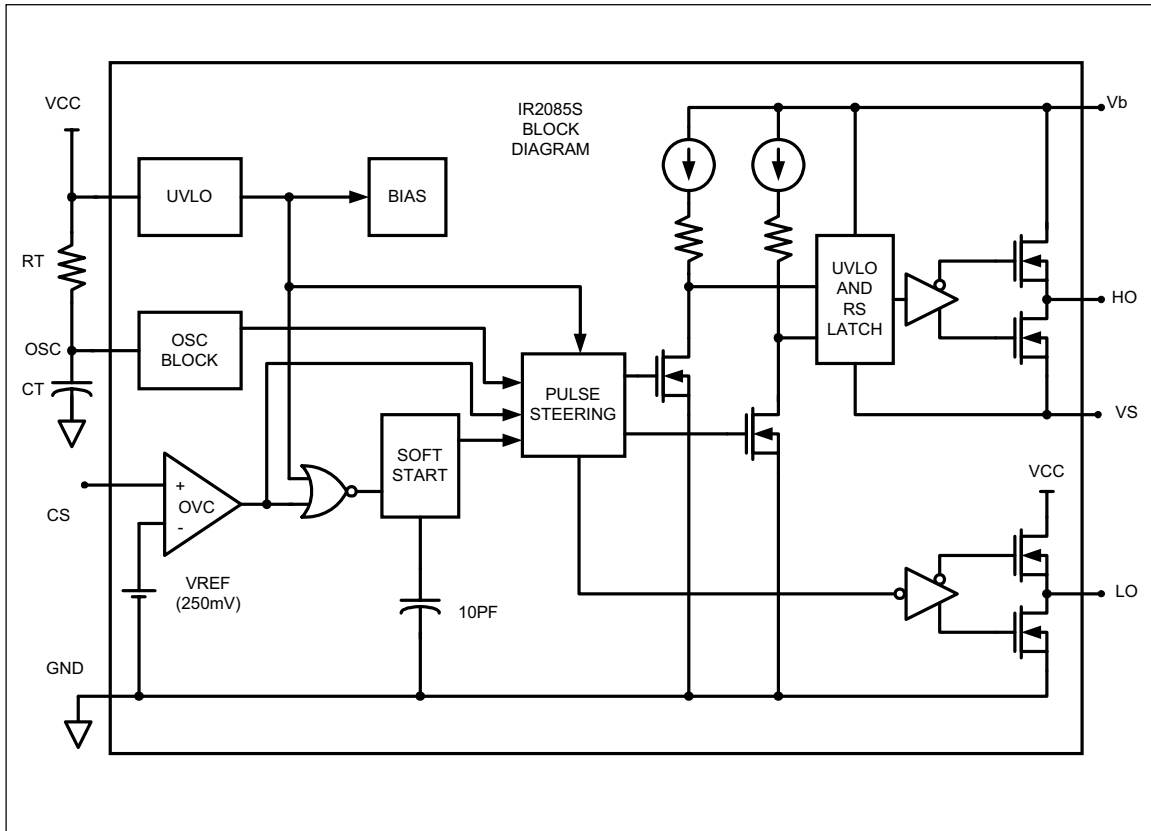

## Lead Definitions

Symbol	Description
VCC	Logic supply
GND	Logic supply return
Vb	High side floating supply
VS	Floating supply return
HO	High side output
LO	Low side output
CS	Current sense input
OSC	Oscillator pin

## Lead Assignments

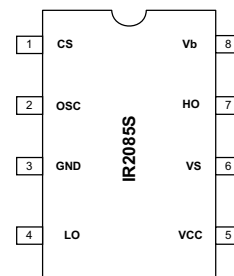

Also available LEAD-FREE (PbF)

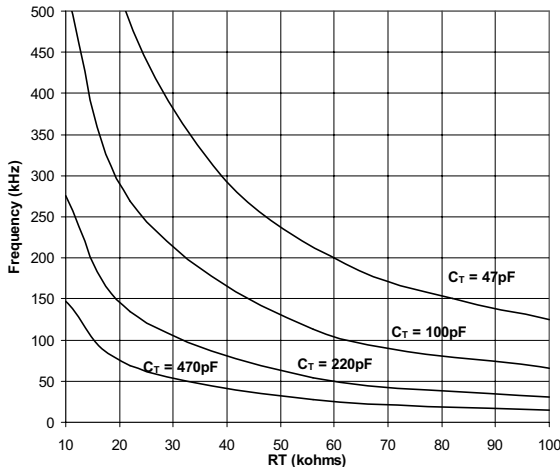

Fig. 1 Typical Output Frequency (-25°C to 125°C)

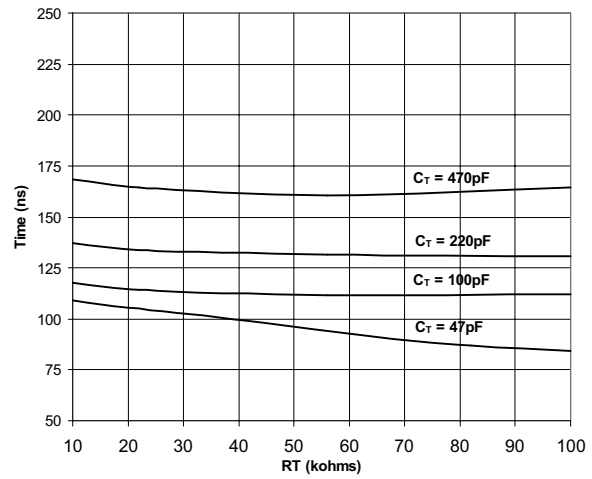

Fig. 2 Typical Dead Time (@25°C)

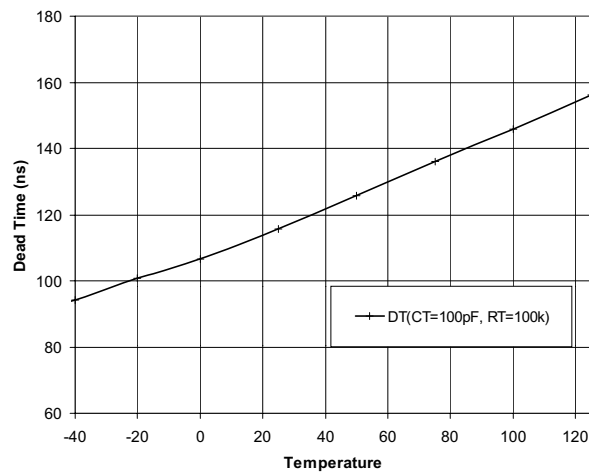

Fig. 3 Typical Dead Time vs Temperature

## Pin Descriptions

**Cs:** The input pin to the overcurrent comparator. Exceeding the overcurrent threshold value specified in “Static Electrical Parameters” Section will terminate output pulses and start a new soft start cycle as soon as the voltage on the pin reduce below the threshold value.

**OSC:** The oscillator-programming pin. Only two components are required to program the internal oscillator frequency: a resistor connected between the  $V_{CC}$  pin and the OSC pin, and a capacitor connected from the OSC to COM. The approximate oscillator frequency is determined by the following simple formula:

$$f_{OSC} = 1 / (2 \cdot R_T \cdot C_T)$$

Where frequency is in Hertz (Hz),  $R_T$  resistance in Ohms ( $\Omega$ ) and  $C_T$  capacitance in Farads (F). The recommended range of timing resistors is between 10k $\Omega$  and 100k $\Omega$  and range of time capacitances is between 47pF and 470pF. The timing resistors less than 10k $\Omega$  should be avoided. The value of the timing capacitor determines the amount of dead time between the two output drivers: lower the  $C_T$ , shorter the dead time and vice versa. It is not recommended to use a timing capacitor below 47pF, for best performance keep the timing components physically as close as possible to the IR2085S. Separated ground and  $V_{CC}$  traces to the timing components are encouraged.

**COM:** Signal ground and power ground for all functions. Due to high current and high frequency operation, a low impedance circuit board ground plane is highly recommended.

**HO, LO:** High side and low side gate drive pins. The high and low side drivers can directly drive the gate of a power MOSFET. The drivers are capable of 1A peak source and sink currents. It is recommended that the high and low drive pins be very close to the gates of the high side and low side MOSFETs to prevent any delay and distortion of the drive signals.

**V<sub>B</sub>:** The high side power input connection. The high side supply is derived from a bootstrap circuit using a low-leakage Schottky diode and a ceramic capacitor. To prevent noise, the Schottky diode and bypass capacitor should be very close to the IR2085S.

**V<sub>S</sub>:** The high side power return connection.  $V_S$  should be connected directly to the source terminal of high side MOSFET with a trace as short as possible.

**V<sub>CC</sub>:** The IC bias input connection for the device. Although the quiescent  $V_{CC}$  current is very low, total supply current will be higher, depending on the gate charge of the MOSFETs connected to the HO and LO pins, and the programmed oscillator frequency, total  $V_{CC}$  current is the sum of quiescent  $V_{CC}$  current and the average current at HO and LO. Knowing the operating frequency and the MOSFET gate charge (Qg) at selected  $V_{CC}$  voltage, the average current can be calculated from:

$$I_{ave} = 2 \times Q_g \times f_{OSC}$$

To prevent noise problem, a bypass ceramic capacitor connected to  $V_{CC}$  and COM should be placed as close as possible to the IR2085S.

IR2085S has an under voltage lookout feature for the IC bias supply,  $V_{CC}$ . The minimum voltage required on  $V_{CC}$  to make sure that IC will work within specifications must be higher than 8.5V (9.5V minimum  $V_{CC}$  is recommended to prevent asymmetrical gates signal on HO and LO pins that are expected when  $V_{CC}$  is between 7.5V and 8.5V).

## Case outline

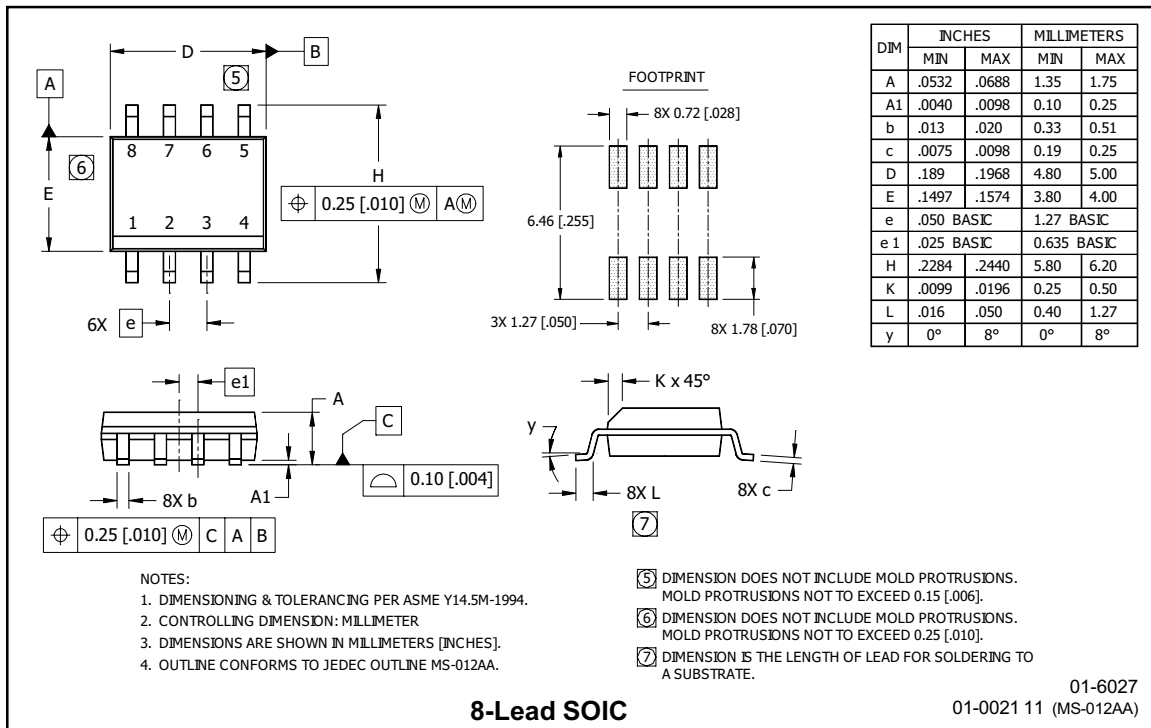

# IR2085S & (PbF)

## LEADFREE PART MARKING INFORMATION

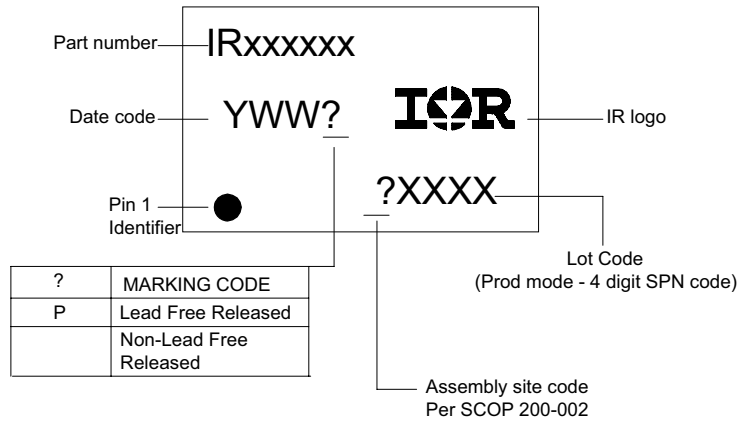



## ORDERING INFORMATION

PKG DESIG	PART NUMBER	LEADFREE PART NUMBER	PIN COUNT	PARTS PER TUBE	PARTS PER REEL
S	IR2085S	IR2085SPbF	8	95	-----
S	IR2085STR	IR2085STRPbF	8	-----	4000

## Looking for pricing, stock, or lifecycle information?

Click below to explore more details on WIN SOURCE:

-  [View IR2085S on WIN SOURCE](#)
-  [Infineon Technologies](#) Information

## Optimize Your Supply Chain with WIN SOURCE Solutions

-  Global Sourcing Solution
-  Obsolete Management
-  Cost Control Management
-  Shortage Management
-  Alternative Solution
-  Excess Inventory Management