



**THE DATASHEET OF  
HEF40175BT,653**





# HEF40175B

Quad D-type flip-flop

Rev. 11 — 8 August 2024

Product data sheet

## 1. General description

The HEF40175B is a quad positive edge triggered D-type flip-flop with four data ( $D_n$ ) inputs, common clock (CP) and asynchronous master reset ( $\overline{MR}$ ) inputs, and complementary  $Q_n$  and  $\overline{Q}_n$  outputs. When  $\overline{MR}$  is HIGH data at the D-input that meets the set-up and hold time requirements on the LOW-to-HIGH clock transition will be stored in the flip-flop and appear at the Q output. When LOW,  $\overline{MR}$  resets all flip-flops ( $Q_n = \text{LOW}$ ,  $\overline{Q}_n = \text{HIGH}$ ), independent of CP and  $D_n$ . Inputs include clamp diodes. This enables the use of current limiting resistors to interface inputs to voltages in excess of  $V_{DD}$ .

## 2. Features and benefits

- Wide supply voltage range from 3.0 V to 15.0 V
- CMOS low power dissipation
- High noise immunity
- Fully static operation
- 5 V, 10 V, and 15 V parametric ratings
- Standardized symmetrical output characteristics
- Complies with JEDEC standard JESD 13-B
- ESD protection:
  - HBM: ANSI/ESDA/JEDEC JS-001 class 2 exceeds 2000 V
  - CDM: ANSI/ESDA/JEDEC JS-002 class C3 exceeds 1000 V
- Specified from -40 °C to +85°C and from -40 °C to +125 °C

## 3. Applications

- Shift registers
- Buffer/storage register
- Pattern generator

## 4. Ordering information

Table 1. Ordering information

Type number	Package			Version
	Temperature range	Name	Description	
<a href="#">HEF40175BT</a>	-40 °C to +125 °C	SO16	plastic small outline package; 16 leads; body width 3.9 mm	<a href="#">SOT109-1</a>
<a href="#">HEF40175BTT</a>	-40 °C to +125 °C	TSSOP16	plastic thin shrink small outline package; 16 leads; body width 4.4 mm	<a href="#">SOT403-1</a>

### 5. Functional diagram

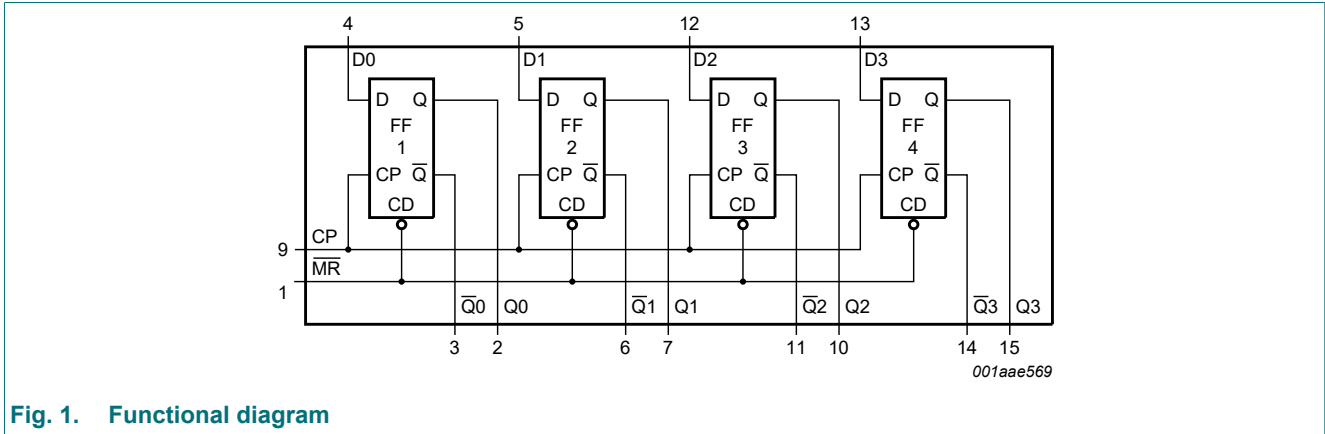

Fig. 1. Functional diagram

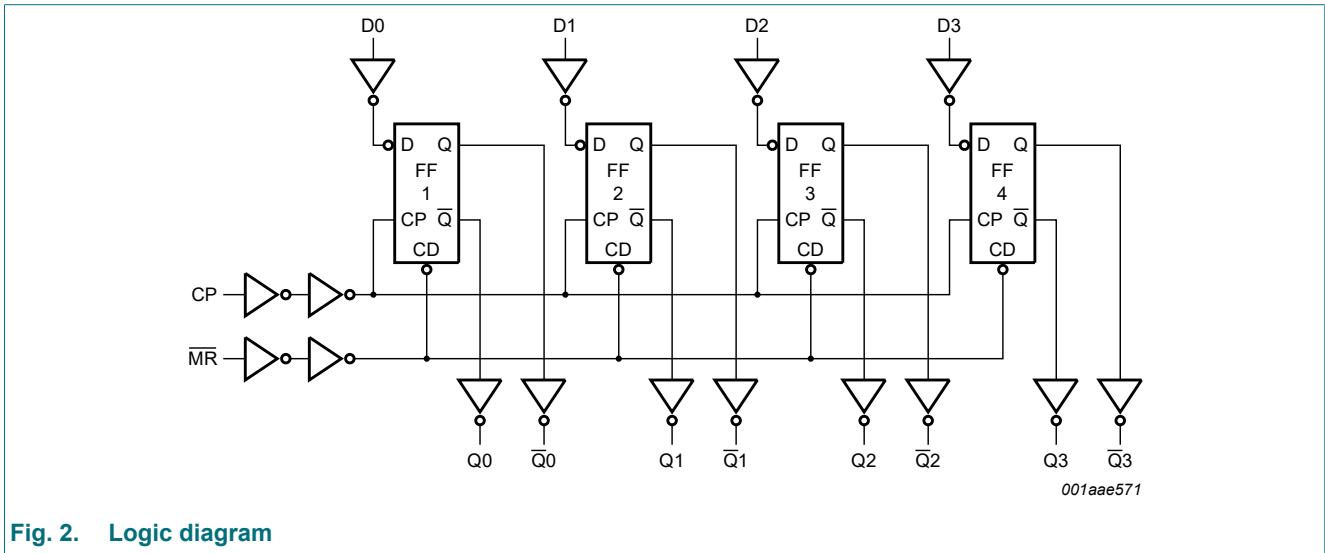
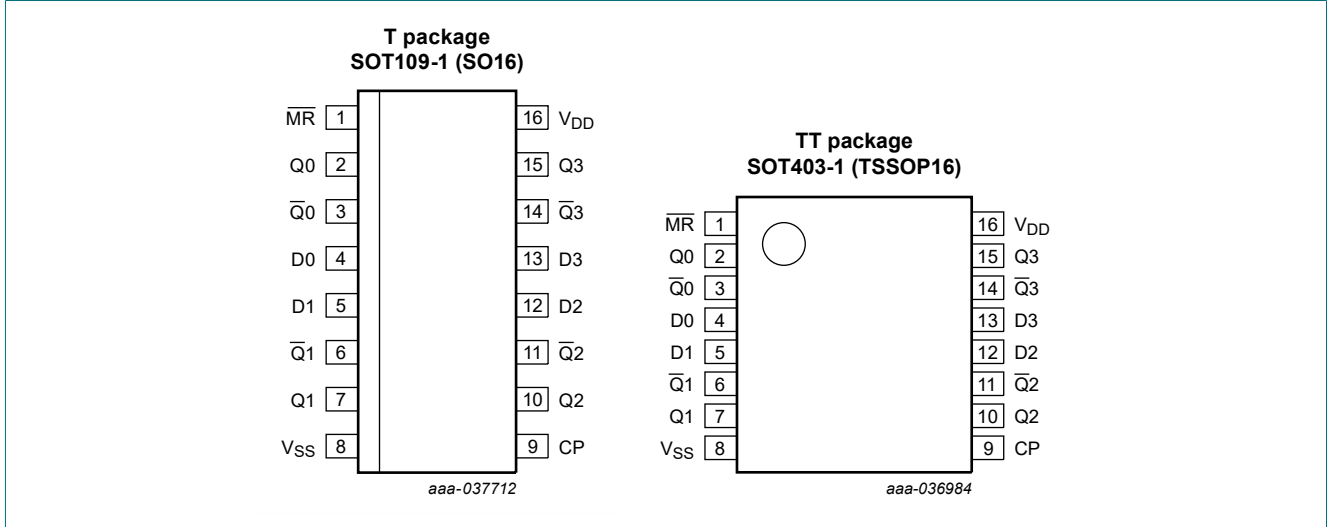

Fig. 2. Logic diagram

## 6. Pinning information

### 6.1. Pinning



### 6.2. Pin description

Table 2. Pin description

Symbol	Pin	Description
MR	1	master reset input (active LOW)
Q0, Q1, Q2, Q3	2, 7, 10, 15	buffered output
Q̄0, Q̄1, Q̄2, Q̄3	3, 6, 11, 14	complementary buffered output
D0, D1, D2, D3	4, 5, 12, 13	data input
VSS	8	ground supply voltage
CP	9	clock input (LOW-to-HIGH edge-triggered)
VDD	16	supply voltage

## 7. Functional description

Table 3. Function table

H = HIGH voltage level; L = LOW voltage level; X = don't care;

↑ = positive-going transition; ↓ = negative-going transition.

Input			Output	
CP	Dn	MR	Qn	Q̄n
↑	H	H	H	L
↑	L	H	L	H
↓	X	H	no change	no change
X	X	L	L	H

## 8. Limiting values

**Table 4. Limiting values**

In accordance with the Absolute Maximum Rating System (IEC 60134).

Symbol	Parameter	Conditions	Min	Max	Unit
$V_{DD}$	supply voltage		-0.5	+18	V
$I_{IK}$	input clamping current	$V_I < -0.5\text{ V}$ or $V_I > V_{DD} + 0.5\text{ V}$	-	$\pm 10$	mA
$V_I$	input voltage		-0.5	$V_{DD} + 0.5$	V
$I_{OK}$	output clamping current	$V_O < -0.5\text{ V}$ or $V_O > V_{DD} + 0.5\text{ V}$	-	$\pm 10$	mA
$I_{I/O}$	input/output current		-	$\pm 10$	mA
$I_{DD}$	supply current		-	50	mA
$T_{stg}$	storage temperature		-65	+150	°C
$T_{amb}$	ambient temperature		-40	+125	°C
$P_{tot}$	total power dissipation	$T_{amb} = -40\text{ °C}$ to $+125\text{ °C}$ [1]	-	500	mW
$P$	power dissipation	per output	-	100	mW

[1] For SOT109-1 (SO16) package:  $P_{tot}$  derates linearly with 12.4 mW/K above 110 °C.  
For SOT403-1 (TSSOP16) package:  $P_{tot}$  derates linearly with 8.5 mW/K above 91 °C.

## 9. Recommended operating conditions

**Table 5. Recommended operating conditions**

Symbol	Parameter	Conditions	Min	Typ	Max	Unit
$V_{DD}$	supply voltage		3	-	15	V
$V_I$	input voltage		0	-	$V_{DD}$	V
$T_{amb}$	ambient temperature	in free air	-40	-	+125	°C
$\Delta t/\Delta V$	input transition rise and fall rate	$V_{DD} = 5\text{ V}$	-	-	3.75	$\mu\text{s/V}$
		$V_{DD} = 10\text{ V}$	-	-	0.5	$\mu\text{s/V}$
		$V_{DD} = 15\text{ V}$	-	-	0.08	$\mu\text{s/V}$

## 10. Static characteristics

**Table 6. Static characteristics**

$V_{SS} = 0\text{ V}$ ;  $V_I = V_{SS}$  or  $V_{DD}$  unless otherwise specified.

Symbol	Parameter	Conditions	V <sub>DD</sub>	T <sub>amb</sub> = -40 °C		T <sub>amb</sub> = +25 °C		T <sub>amb</sub> = +85 °C		T <sub>amb</sub> = +125 °C		Unit
				Min	Max	Min	Max	Min	Max	Min	Max	
V <sub>IH</sub>	HIGH-level input voltage	I <sub>O</sub>   < 1 μA	5 V	3.5	-	3.5	-	3.5	-	3.5	-	V
			10 V	7.0	-	7.0	-	7.0	-	7.0	-	V
			15 V	11.0	-	11.0	-	11.0	-	11.0	-	V
V <sub>IL</sub>	LOW-level input voltage	I <sub>O</sub>   < 1 μA	5 V	-	1.5	-	1.5	-	1.5	-	1.5	V
			10 V	-	3.0	-	3.0	-	3.0	-	3.0	V
			15 V	-	4.0	-	4.0	-	4.0	-	4.0	V
V <sub>OH</sub>	HIGH-level output voltage	I <sub>O</sub>   < 1 μA	5 V	4.95	-	4.95	-	4.95	-	4.95	-	V
			10 V	9.95	-	9.95	-	9.95	-	9.95	-	V
			15 V	14.95	-	14.95	-	14.95	-	14.95	-	V
V <sub>OL</sub>	LOW-level output voltage	I <sub>O</sub>   < 1 μA	5 V	-	0.05	-	0.05	-	0.05	-	0.05	V
			10 V	-	0.05	-	0.05	-	0.05	-	0.05	V
			15 V	-	0.05	-	0.05	-	0.05	-	0.05	V
I <sub>OH</sub>	HIGH-level output current	V <sub>O</sub> = 2.5 V	5 V	-	-1.7	-	-1.4	-	-1.1	-	-1.1	mA
		V <sub>O</sub> = 4.6 V	5 V	-	-0.64	-	-0.5	-	-0.36	-	-0.36	mA
		V <sub>O</sub> = 9.5 V	10 V	-	-1.6	-	-1.3	-	-0.9	-	-0.9	mA
		V <sub>O</sub> = 13.5 V	15 V	-	-4.2	-	-3.4	-	-2.4	-	-2.4	mA
I <sub>OL</sub>	LOW-level output current	V <sub>O</sub> = 0.4 V	5 V	0.64	-	0.5	-	0.36	-	0.36	-	mA
		V <sub>O</sub> = 0.5 V	10 V	1.6	-	1.3	-	0.9	-	0.9	-	mA
		V <sub>O</sub> = 1.5 V	15 V	4.2	-	3.4	-	2.4	-	2.4	-	mA
I <sub>I</sub>	input leakage current		15 V	-	±0.1	-	±0.1	-	±1.0	-	±1.0	μA
I <sub>DD</sub>	supply current	all valid input combinations;  I <sub>O</sub>   = 0 A	5 V	-	1.0	-	1.0	-	30	-	30	μA
			10 V	-	2.0	-	2.0	-	60	-	60	μA
			15 V	-	4.0	-	4.0	-	120	-	120	μA
C <sub>I</sub>	input capacitance		-	-	-	7.5	-	-	-	-	pF	

## 11. Dynamic characteristics

**Table 7. Dynamic characteristics**

$V_{SS} = 0\text{ V}$ ;  $T_{amb} = 25\text{ °C}$  unless otherwise specified; for test circuit see Fig. 4.

Symbol	Parameter	Conditions	V <sub>DD</sub>	Extrapolation formula[1]	Min	Typ	Max	Unit
t <sub>PHL</sub>	HIGH to LOW propagation delay	CP to Qn or $\bar{Q}n$ ; see Fig. 3	5 V	53 ns + (0.55 ns/pF) C <sub>L</sub>	-	80	160	ns
			10 V	24 ns + (0.23 ns/pF) C <sub>L</sub>	-	35	70	ns
			15 V	17 ns + (0.16 ns/pF) C <sub>L</sub>	-	25	50	ns
		$\bar{MR}$ to Qn; see Fig. 3	5 V	48 ns + (0.55 ns/pF) C <sub>L</sub>	-	75	155	ns
			10 V	19 ns + (0.23 ns/pF) C <sub>L</sub>	-	30	65	ns
			15 V	17 ns + (0.16 ns/pF) C <sub>L</sub>	-	25	50	ns
t <sub>PLH</sub>	LOW to HIGH propagation delay	CP to Qn or $\bar{Q}n$ ; see Fig. 3	5 V	43 ns + (0.55 ns/pF) C <sub>L</sub>	-	70	140	ns
			10 V	19 ns + (0.23 ns/pF) C <sub>L</sub>	-	30	65	ns
			15 V	17 ns + (0.16 ns/pF) C <sub>L</sub>	-	25	45	ns
		$\bar{MR}$ to $\bar{Q}n$ ; see Fig. 3	5 V	43 ns + (0.55 ns/pF) C <sub>L</sub>	-	70	140	ns
			10 V	19 ns + (0.23 ns/pF) C <sub>L</sub>	-	30	65	ns
			15 V	17 ns + (0.16 ns/pF) C <sub>L</sub>	-	25	50	ns
t <sub>t</sub>	transition time	see Fig. 3	5 V	10 ns + (1.00 ns/pF) C <sub>L</sub>	-	60	120	ns
			10 V	9 ns + (0.42 ns/pF) C <sub>L</sub>	-	30	60	ns
			15 V	6 ns + (0.28 ns/pF) C <sub>L</sub>	-	20	40	ns
t <sub>su</sub>	set-up time	Dn to CP; see Fig. 3	5 V		60	30	-	ns
			10 V		20	10	-	ns
			15 V		15	5	-	ns
t <sub>h</sub>	hold time	Dn to CP; see Fig. 3	5 V		+25	-5	-	ns
			10 V		10	0	-	ns
			15 V		10	0	-	ns
t <sub>w</sub>	pulse width	CP input LOW; minimum pulse width; see Fig. 3	5 V		90	45	-	ns
			10 V		35	15	-	ns
			15 V		25	10	-	ns
		$\bar{MR}$ input LOW; minimum pulse width; see Fig. 3	5 V		80	40	-	ns
			10 V		30	15	-	ns
			15 V		20	10	-	ns
t <sub>rec</sub>	recovery time	$\bar{MR}$ input; see Fig. 3	5 V		0	-30	-	ns
			10 V		0	-20	-	ns
			15 V		0	-15	-	ns
f <sub>max</sub>	maximum frequency		5 V		5	11	-	MHz
			10 V		15	30	-	MHz
			15 V		20	45	-	MHz

[1] The typical values of the propagation delay and transition times are calculated from the extrapolation formula shown (C<sub>L</sub> in pF).

**Table 8. Dynamic power dissipation  $P_D$**

$P_D$  can be calculated from the formulas shown.  $V_{SS} = 0\text{ V}$ ;  $t_r = t_f \leq 20\text{ ns}$ ;  $T_{amb} = 25\text{ }^\circ\text{C}$ .

Symbol	Parameter	$V_{DD}$	Typical formula for $P_D$ ( $\mu\text{W}$ )	where:
$P_D$	dynamic power dissipation	5 V	$P_D = 2000 \times f_i + \Sigma(f_o \times C_L) \times V_{DD}^2$	$f_i$ = input frequency in MHz; $f_o$ = output frequency in MHz; $C_L$ = output load capacitance in pF; $V_{DD}$ = supply voltage in V; $\Sigma(f_o \times C_L)$ = sum of the outputs.
		10 V	$P_D = 8400 \times f_i + \Sigma(f_o \times C_L) \times V_{DD}^2$	
		15 V	$P_D = 22500 \times f_i + \Sigma(f_o \times C_L) \times V_{DD}^2$	

### 11.1. Waveforms and test circuit

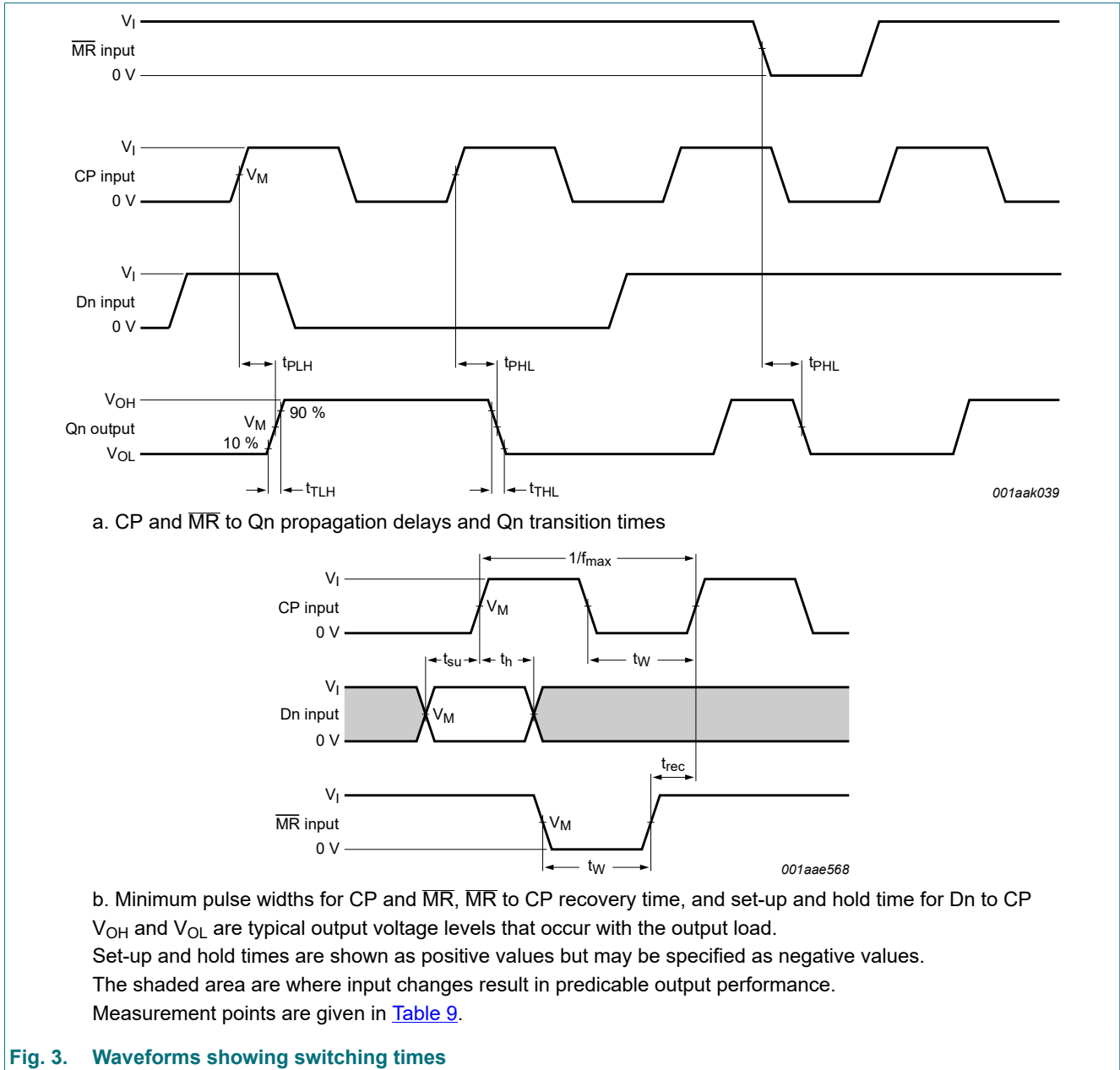

**Fig. 3. Waveforms showing switching times**

Table 9. Measurement points

Supply voltage	Input	Output
$V_{DD}$	$V_M$	$V_M$
5 V to 15 V	$0.5 \times V_{DD}$	$0.5 \times V_{DD}$

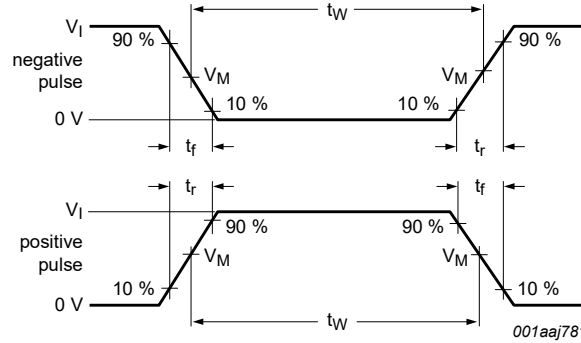

a. Input waveforms

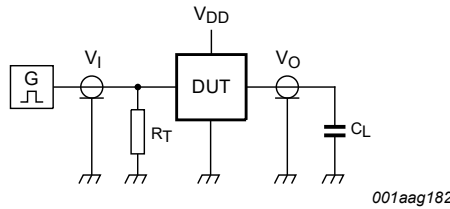

b. Test circuit

Test and measurement data is given in [Table 10](#).

Definitions test circuit:

$R_T$  = Termination resistance should be equal to output impedance  $Z_o$  of the pulse generator;

$C_L$  = Load capacitance including jig and probe capacitance.

Fig. 4. Test circuit for measuring switching times

Table 10. Measurement points and test data

Supply voltage	Input	Load
$V_{DD}$	$V_I$	$C_L$
5 V to 15 V	$V_{SS}$ or $V_{DD}$	50 pF

12. Package outline

SO16: plastic small outline package; 16 leads; body width 3.9 mm

SOT109-1

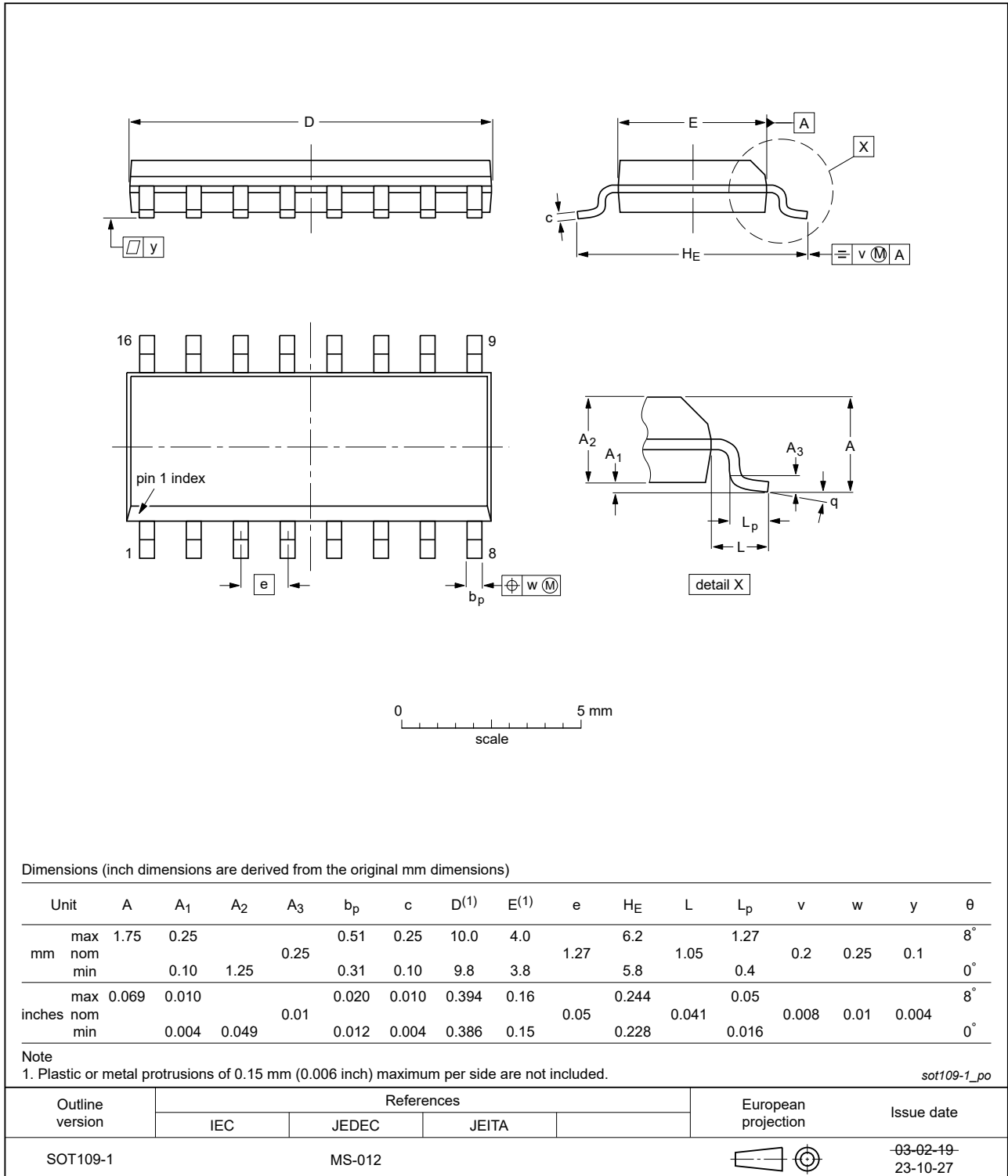

Fig. 5. Package outline SOT109-1 (SO16)

TSSOP16: plastic thin shrink small outline package; 16 leads; body width 4.4 mm

SOT403-1

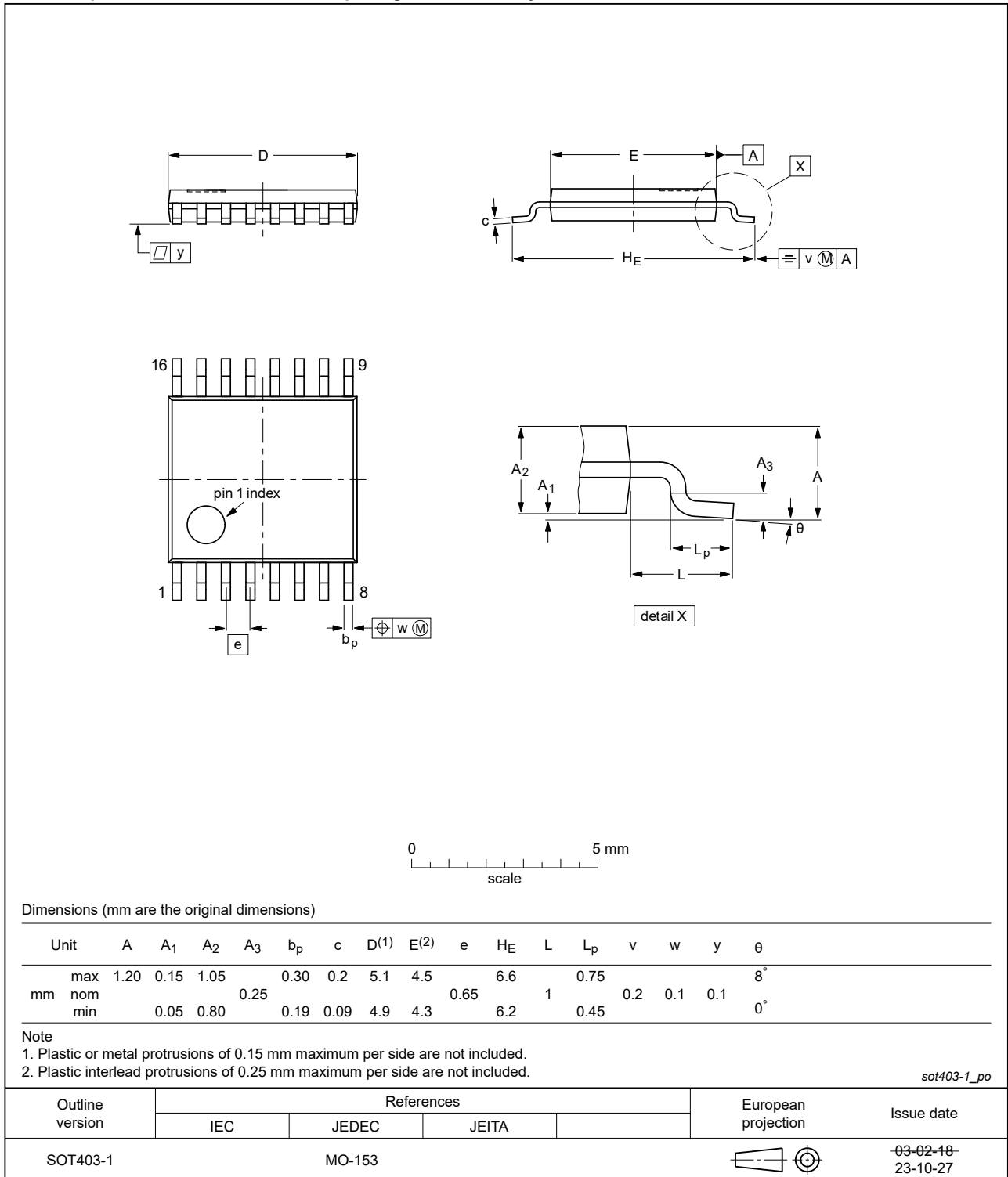

Fig. 6. Package outline SOT403-1 (TSSOP16)

## 13. Abbreviations

Table 11. Abbreviations

Acronym	Description
ANSI	American National Standards Institute
CDM	Charged Device Model
CMOS	Complementary Metal-Oxide Semiconductor
DUT	Device Under Test
ESD	ElectroStatic Discharge
ESDA	ElectroStatic Discharge Association
HBM	Human Body Model
JEDEC	Joint Electron Device Engineering Council

## 14. Revision history

Table 12. Revision history

Document ID	Release date	Data sheet status	Change notice	Supersedes
HEF40175B v.11	20240808	Product data sheet	-	HEF40175B v.10.1
Modifications:	<ul style="list-style-type: none"> <li>• <a href="#">Section 2</a>: ESD specification updated according to the latest JEDEC standard.</li> <li>• <a href="#">Fig. 5</a>, <a href="#">Fig. 6</a>: Aligned SO and TSSOP package outline drawings to JEDEC MS-012 and MO-153</li> </ul>			
HEF40175B v.10.1	20231020	Product data sheet	-	HEF40175B v.9
Modifications:	<ul style="list-style-type: none"> <li>• The format of this data sheet has been redesigned to comply with the identity guidelines of Nexperia.</li> <li>• Legal texts have been adapted to the new company name where appropriate.</li> <li>• <a href="#">Section 1</a> and <a href="#">Section 2</a> updated.</li> <li>• <a href="#">Table 4</a>: Derating values for <math>P_{tot}</math> total power dissipation updated.</li> </ul>			
HEF40175B v.9	20160321	Product data sheet	-	HEF40175B v.8
Modifications:	<ul style="list-style-type: none"> <li>• Type number HEF40175BP (SOT38-4) removed.</li> </ul>			
HEF40175B v.8	20111121	Product data sheet	-	HEF40175B v.7
Modifications:	<ul style="list-style-type: none"> <li>• Legal pages updated.</li> <li>• Changes in "General description", "Features and benefits" and "Applications".</li> </ul>			
HEF40175B v.7	20110503	Product data sheet	-	HEF40175B v.6
HEF40175B v.6	20101214	Product data sheet	-	HEF40175B v.5
HEF40175B v.5	20100105	Product data sheet	-	HEF40175B v.4
HEF40175B v.4	20090813	Product data sheet	-	HEF40175B_CNV v.3
HEF40175B_CNV v.3	19950101	Product specification	-	HEF40175B_CNV v.2
HEF40175B_CNV v.2	19950101	Product specification	-	-

## 15. Legal information

### Data sheet status

Document status [1][2]	Product status [3]	Definition
Objective [short] data sheet	Development	This document contains data from the objective specification for product development.
Preliminary [short] data sheet	Qualification	This document contains data from the preliminary specification.
Product [short] data sheet	Production	This document contains the product specification.

- [1] Please consult the most recently issued document before initiating or completing a design.
- [2] The term 'short data sheet' is explained in section "Definitions".
- [3] The product status of device(s) described in this document may have changed since this document was published and may differ in case of multiple devices. The latest product status information is available on the internet at <https://www.nexperia.com>.

### Definitions

**Draft** — The document is a draft version only. The content is still under internal review and subject to formal approval, which may result in modifications or additions. Nexperia does not give any representations or warranties as to the accuracy or completeness of information included herein and shall have no liability for the consequences of use of such information.

**Short data sheet** — A short data sheet is an extract from a full data sheet with the same product type number(s) and title. A short data sheet is intended for quick reference only and should not be relied upon to contain detailed and full information. For detailed and full information see the relevant full data sheet, which is available on request via the local Nexperia sales office. In case of any inconsistency or conflict with the short data sheet, the full data sheet shall prevail.

**Product specification** — The information and data provided in a Product data sheet shall define the specification of the product as agreed between Nexperia and its customer, unless Nexperia and customer have explicitly agreed otherwise in writing. In no event however, shall an agreement be valid in which the Nexperia product is deemed to offer functions and qualities beyond those described in the Product data sheet.

### Disclaimers

**Limited warranty and liability** — Information in this document is believed to be accurate and reliable. However, Nexperia does not give any representations or warranties, expressed or implied, as to the accuracy or completeness of such information and shall have no liability for the consequences of use of such information. Nexperia takes no responsibility for the content in this document if provided by an information source outside of Nexperia.

In no event shall Nexperia be liable for any indirect, incidental, punitive, special or consequential damages (including - without limitation - lost profits, lost savings, business interruption, costs related to the removal or replacement of any products or rework charges) whether or not such damages are based on tort (including negligence), warranty, breach of contract or any other legal theory.

Notwithstanding any damages that customer might incur for any reason whatsoever, Nexperia's aggregate and cumulative liability towards customer for the products described herein shall be limited in accordance with the Terms and conditions of commercial sale of Nexperia.

**Right to make changes** — Nexperia reserves the right to make changes to information published in this document, including without limitation specifications and product descriptions, at any time and without notice. This document supersedes and replaces all information supplied prior to the publication hereof.

**Suitability for use** — Nexperia products are not designed, authorized or warranted to be suitable for use in life support, life-critical or safety-critical systems or equipment, nor in applications where failure or malfunction of an Nexperia product can reasonably be expected to result in personal

injury, death or severe property or environmental damage. Nexperia and its suppliers accept no liability for inclusion and/or use of Nexperia products in such equipment or applications and therefore such inclusion and/or use is at the customer's own risk.

**Quick reference data** — The Quick reference data is an extract of the product data given in the Limiting values and Characteristics sections of this document, and as such is not complete, exhaustive or legally binding.

**Applications** — Applications that are described herein for any of these products are for illustrative purposes only. Nexperia makes no representation or warranty that such applications will be suitable for the specified use without further testing or modification.

Customers are responsible for the design and operation of their applications and products using Nexperia products, and Nexperia accepts no liability for any assistance with applications or customer product design. It is customer's sole responsibility to determine whether the Nexperia product is suitable and fit for the customer's applications and products planned, as well as for the planned application and use of customer's third party customer(s). Customers should provide appropriate design and operating safeguards to minimize the risks associated with their applications and products.

Nexperia does not accept any liability related to any default, damage, costs or problem which is based on any weakness or default in the customer's applications or products, or the application or use by customer's third party customer(s). Customer is responsible for doing all necessary testing for the customer's applications and products using Nexperia products in order to avoid a default of the applications and the products or of the application or use by customer's third party customer(s). Nexperia does not accept any liability in this respect.

**Limiting values** — Stress above one or more limiting values (as defined in the Absolute Maximum Ratings System of IEC 60134) will cause permanent damage to the device. Limiting values are stress ratings only and (proper) operation of the device at these or any other conditions above those given in the Recommended operating conditions section (if present) or the Characteristics sections of this document is not warranted. Constant or repeated exposure to limiting values will permanently and irreversibly affect the quality and reliability of the device.

**Terms and conditions of commercial sale** — Nexperia products are sold subject to the general terms and conditions of commercial sale, as published at <http://www.nexperia.com/profile/terms>, unless otherwise agreed in a valid written individual agreement. In case an individual agreement is concluded only the terms and conditions of the respective agreement shall apply. Nexperia hereby expressly objects to applying the customer's general terms and conditions with regard to the purchase of Nexperia products by customer.

**No offer to sell or license** — Nothing in this document may be interpreted or construed as an offer to sell products that is open for acceptance or the grant, conveyance or implication of any license under any copyrights, patents or other industrial or intellectual property rights.

**Export control** — This document as well as the item(s) described herein may be subject to export control regulations. Export might require a prior authorization from competent authorities.

**Non-automotive qualified products** — Unless this data sheet expressly states that this specific Nexperia product is automotive qualified, the product is not suitable for automotive use. It is neither qualified nor tested in accordance with automotive testing or application requirements. Nexperia accepts no liability for inclusion and/or use of non-automotive qualified products in automotive equipment or applications.

In the event that customer uses the product for design-in and use in automotive applications to automotive specifications and standards, customer (a) shall use the product without Nexperia's warranty of the product for such automotive applications, use and specifications, and (b) whenever customer uses the product for automotive applications beyond Nexperia's specifications such use shall be solely at customer's own risk, and (c) customer fully indemnifies Nexperia for any liability, damages or failed product claims resulting from customer design and use of the product for automotive applications beyond Nexperia's standard warranty and Nexperia's product specifications.

**Translations** — A non-English (translated) version of a document is for reference only. The English version shall prevail in case of any discrepancy between the translated and English versions.

### Trademarks

Notice: All referenced brands, product names, service names and trademarks are the property of their respective owners.

## Contents

<b>1. General description</b> .....	<b>1</b>
<b>2. Features and benefits</b> .....	<b>1</b>
<b>3. Applications</b> .....	<b>1</b>
<b>4. Ordering information</b> .....	<b>1</b>
<b>5. Functional diagram</b> .....	<b>2</b>
<b>6. Pinning information</b> .....	<b>3</b>
6.1. Pinning.....	3
6.2. Pin description.....	3
<b>7. Functional description</b> .....	<b>3</b>
<b>8. Limiting values</b> .....	<b>4</b>
<b>9. Recommended operating conditions</b> .....	<b>4</b>
<b>10. Static characteristics</b> .....	<b>5</b>
<b>11. Dynamic characteristics</b> .....	<b>6</b>
11.1. Waveforms and test circuit.....	7
<b>12. Package outline</b> .....	<b>9</b>
<b>13. Abbreviations</b> .....	<b>11</b>
<b>14. Revision history</b> .....	<b>11</b>
<b>15. Legal information</b> .....	<b>12</b>

© Nexperia B.V. 2024. All rights reserved

For more information, please visit: <http://www.nexperia.com>

For sales office addresses, please send an email to: [salesaddresses@nexperia.com](mailto:salesaddresses@nexperia.com)

Date of release: 8 August 2024

## Looking for pricing, stock, or lifecycle information?

Click below to explore more details on WIN SOURCE:

 [View HEF40175BT,653 on WIN SOURCE](#)

 [Nexperia USA Inc. Information](#)

## Optimize Your Supply Chain with WIN SOURCE Solutions

-  Global Sourcing Solution
-  Obsolete Management
-  Cost Control Management
-  Shortage Management
-  Alternative Solution
-  Excess Inventory Management