

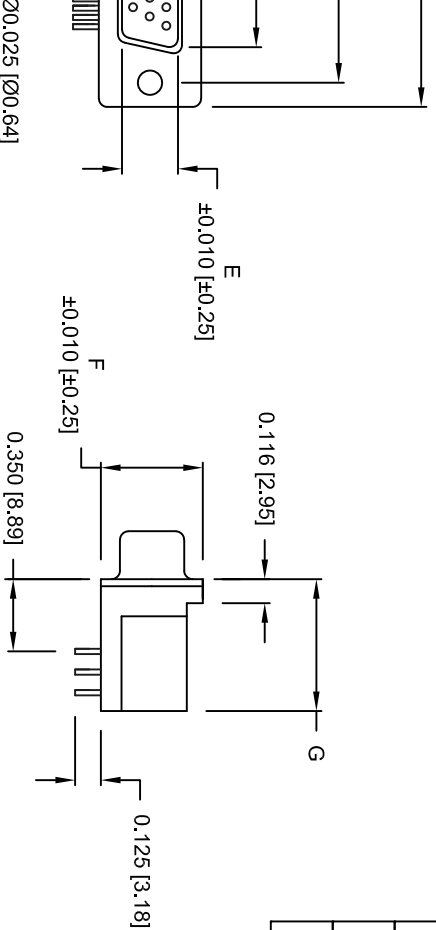

THE DATASHEET OF
181-015-113R531



RIGHT ANGLE



DIMENSIONS (IN.)							
No. OF PINS	A	B	C	D	E	F	G
15	1.213	0.984	0.666	0.090	0.329	0.496	0.639
	30.80	24.99	16.92	2.29	8.36	12.60	16.23
26	1.543	1.312	0.994	0.090	0.329	0.496	0.639
	39.19	33.32	25.25	2.29	8.36	12.60	16.23
44	2.087	1.852	1.534	0.090	0.329	0.496	0.639
	53.00	47.04	38.96	2.29	8.36	12.60	16.23
62	2.732	2.500	2.156	0.095	0.329	0.496	0.639
	69.30	63.50	54.76	2.41	8.36	12.60	16.23

181-YYY-113 R YY 1

SERIES _____
 POSITIONS _____
 015 _____
 026 _____
 044 _____
 062 _____

GENDER _____
 1 = MALE

TERMINATION _____
 1 = DIP SOLDER

SHELL PLATING _____
 3 = NICKEL PLATED

RoHS COMPLIANT _____
 (HIGH TEMP. PROCESS)

HARDWARE OPTIONS _____
 16 = Ø 0.120 HOLE / INSIDE GND STRAPS
 17 = 4-40 INSERTS / INSIDE GND STRAPS
 18 = 4-40 SCREWLOCKS / INSIDE GND STRAPS
 43 = Ø 0.120 HOLE / METAL SHELL
 45 = 4-40 INSERTS / METAL SHELL
 48 = 4-40 SCREWLOCKS / METAL SHELL
 53 = 4-40 INSERTS / BOARDLOCKS
 55 = Ø 0.120 HOLE / BOARDLOCKS
 56 = 4-40 SCREWLOCKS / BOARDLOCKS

PLATING OPTIONS _____
 1 = GOLD FLASH

- 3 AMPS
- 15 MilliOhms Max.
- 1,000 MEGOhms Min. at 500 VDC
- 1,000 VAC FOR 1 MINUTE
- 250 VAC
- 55°C TO +105°C

- 1: SPCC, NICKEL PLATED
- 2: PA9T-BLACK (UL94-0)
- 3: 260°C PROCESS TEMPERATURE
- 4: BRASS, GOLD ENTIRE CONTACT
- 5: COPPER ALLOY, NICKEL PLATED
- 6: SPCC, TIN PLATED
- 7: ZINC ALLOY, NICKEL PLATED

DO NOT SCALE FROM DRAWING



THESE DRAWINGS AND SPECIFICATIONS ARE THE PROPERTY OF NorComp AND SHALL NOT BE REPRODUCED, COPIED OR USED AS THE BASIS FOR THE MANUFACTURE OR SALE OF APPARATUS WITHOUT WRITTEN PERMISSION.

NorComp

DRAWN: PAM JENKINS DATE: 03-17-05

SCALE: NTS SHEET 1 OF 3 REV 15

DWG NO. 181-YYY-113 RYY1

COMPLIANT

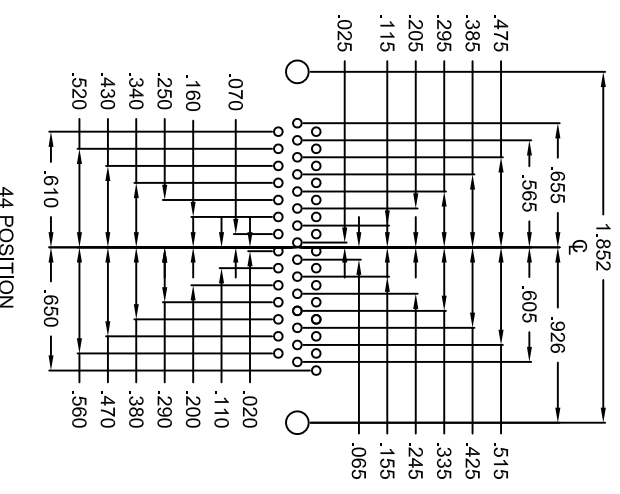
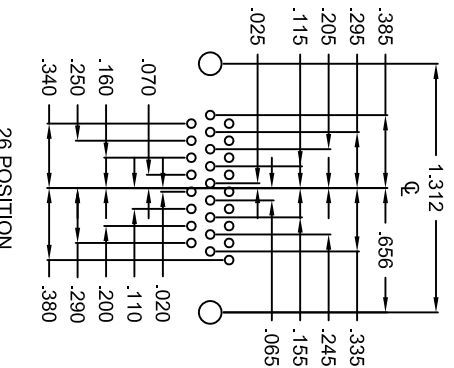
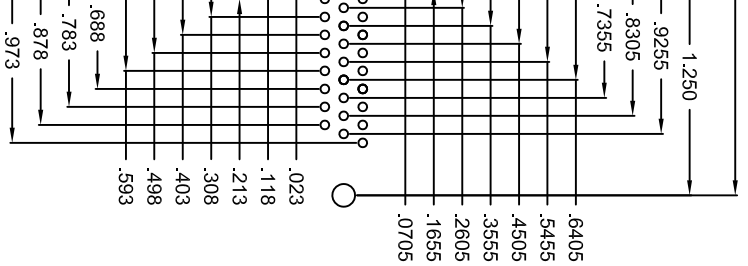
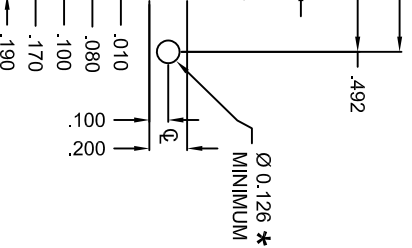

HOLE PATTERN SHOWN
ARE FOR MALE

UNITS = Inch

* TYP.
SUGGESTED SIZE
MAY NOT BE SUITABLE FOR ALL APPLICATIONS

DO NOT SCALE FROM DRAWING

	THESE DRAWINGS AND SPECIFICATIONS ARE THE PROPERTY OF NorComp AND SHALL NOT BE REPRODUCED, COPIED OR USED AS THE BASIS FOR THE MANUFACTURE OR SALE OF APPARATUS WITHOUT WRITTEN PERMISSION.		
	NorComp	DRAWN: PAM JENKINS	DATE: 03-17-05
SCALE: NTS	SHEET 2 OF 3	REV 15	DWG NO. 181-YYY-113RRY1

WARE OPTIONS

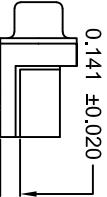
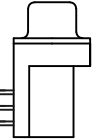
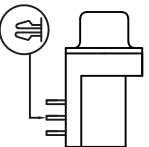
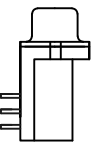
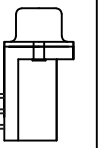
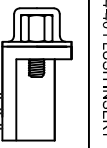
 0.141 ±0.020 METAL SHELL WITH INSIDE GROUND STRAPS	 METAL SHELL	 METAL SHELL FORK BOARD LOCKS	
 .120" DIA. HOLE	16	43	55
 4-40 FLUSH INSERT	17	45	53
 4-40 HEX STANDOFF ⁺ FEMALE SCREWLOCK	18	48	56

*4.80mm Reference Hex Height

DO NOT SCALE FROM DRAWING

	THESE DRAWINGS AND SPECIFICATIONS ARE THE PROPERTY OF NorComp AND SHALL NOT BE REPRODUCED, COPIED OR USED AS THE BASIS FOR THE MANUFACTURE OR SALE OF APPARATUS WITHOUT WRITTEN PERMISSION.		
	DRAWN: PAM JENKINS	DATE: 03-17-05	
SCALE: NTS	SHEET 3	OF 3	REV 15
DWG NO. 181-YYY-113RRY1			

COMPLIANT

NorComp

Looking for pricing, stock, or lifecycle information?

Click below to explore more details on WIN SOURCE:

 [View 181-015-113R531 on WIN SOURCE](#)

 [NorComp Inc. Information](#)

Optimize Your Supply Chain with WIN SOURCE Solutions

-  Global Sourcing Solution
-  Obsolete Management
-  Cost Control Management
-  Shortage Management
-  Alternative Solution
-  Excess Inventory Management