



**THE DATASHEET OF
TEMS-130-02-04.0-H-D-A-K-TR**



**DESIGNED & DIMENSIONED
IN MILLIMETERS [INCHES]**

**DO NOT
SCALE FROM
THIS PRINT**

TEMX-1XX-XX-XX.X-XX-D-XX-X-XX

PACKAGING
 BLANK: TRAY (SEE NOTES 4 & 9)
 -TR: TAPE & REEL (SEE NOTES 9 & 10)
 -FR: FULL REEL QTY TAPE & REEL (SEE NOTES 9 & 10)

PICK & PLACE OPTION
 -K: POLYIMIDE FILM (USE K-DOT-217-.313-.005, SEE FIG 5, SHT 2)

OPTION
 -A: ALIGNMENT PIN (SEE FIG 2, SHT 2) (NOT AVAILABLE WITH -LC, -WT, -L1)
 -LC: LOCKING CLIP (SEE FIG 3, SHT 2) (NOT AVAILABLE WITH -A, -WT, -L1)
 -WT: WELD TAB (SEE FIG 4, SHT 2) (NOT AVAILABLE WITH -A, -LC, -L1)
 -L1: LATCHING (SEE FIG 7, SHT 3) (ONLY AVAILABLE ON -03.0 STACK HEIGHT AND 5 - 20 POS) (NOT AVAILABLE WITH -A, -LC, -WT)

ROW SPECIFICATION
 -D: DOUBLE ROW

BODY OPTION
 (LEAVE BLANK IF OPTION NOT USED)
 S: SLIM (NOT AVAILABLE WITH -LC, -WT OR -L1) (USE TEMS-XX-XX.X, SEE FIG 6, SHT 2) (ONLY AVAILABLE WITH -K-TR)

No OF POSITIONS
 -05 THRU -50 (PER ROW) (5 POS INCREMENTS)

LEAD STYLE
 -02: SURFACE MOUNT

STACK HEIGHT
 -03.0: (6 mm STACK HEIGHT) (T-1M58-03.0-XX)
 -04.0: (7 mm STACK HEIGHT) (T-1M58-04.0-XX)
 -07.0: (10 mm STACK HEIGHT) (T-1M58-07.0-XX)

PLATING SPECIFICATION
 -H: 30µ" HEAVY GOLD IN CONTACT AREA 3µ" ON TAIL
 -G: 10µ" GOLD IN CONTACT AREA 3µ" ON TAIL
 -FG: 3µ" FLASH GOLD ON ENTIRE TERMINAL

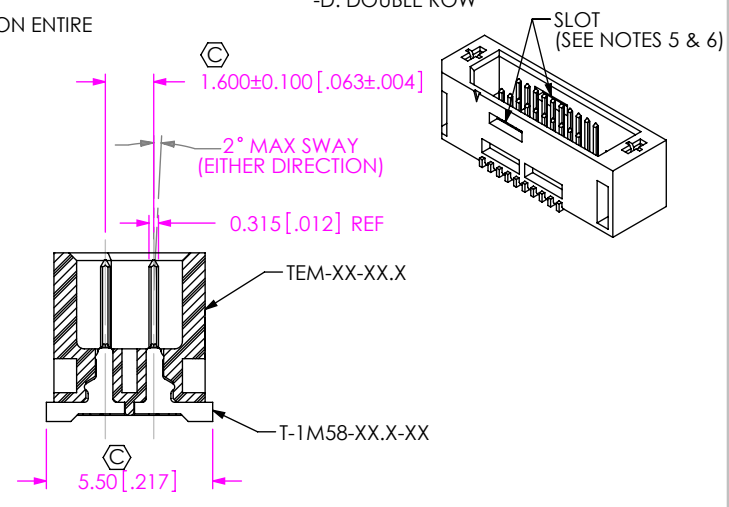
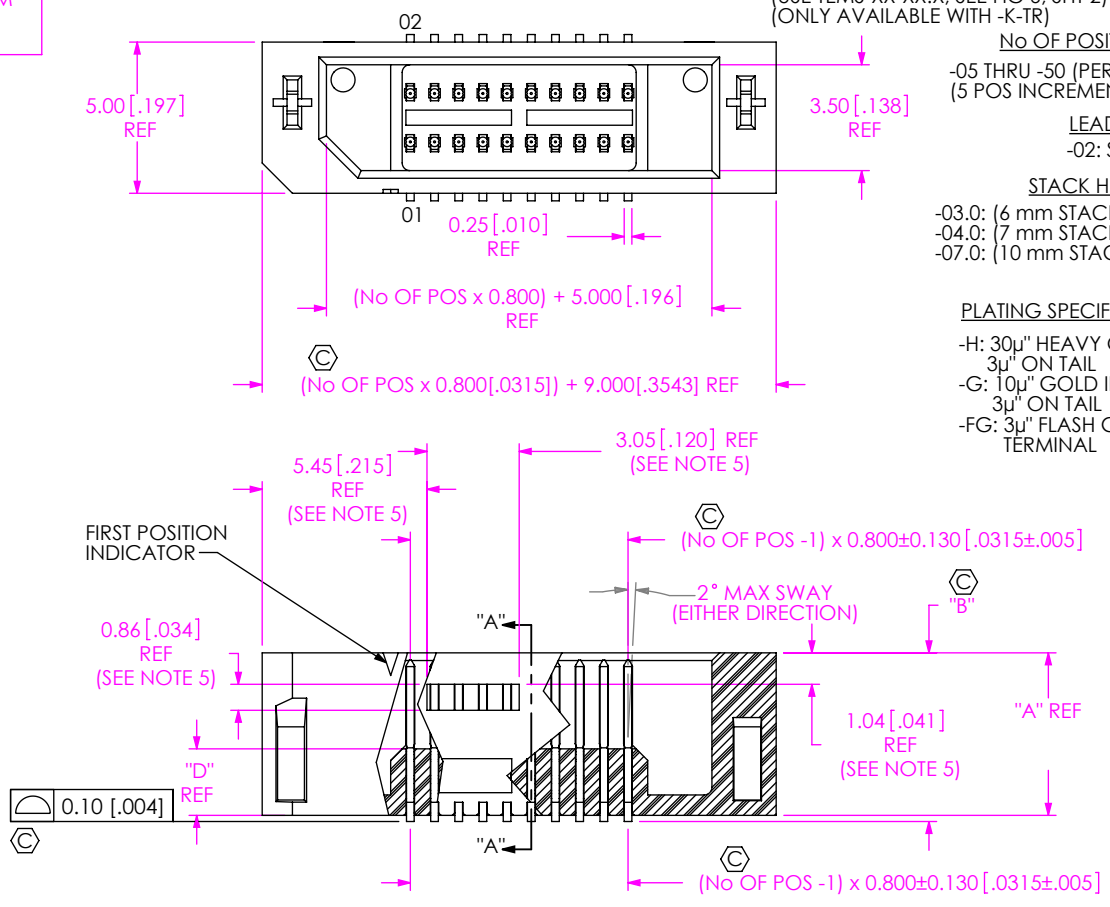

SECTION "A"- "A"

FIG 1
 TEM-110-02-03.0-XX-D SHOWN

STACK HEIGHT	"A"	"B"	"C"	"D"
-03.0	5.375 [.2116]	5.610 [.2209]	5.742 [.2261]	2.200 [.0866]
-04.0	6.375 [.2510]	6.610 [.2602]	6.742 [.2654]	3.200 [.1260]
-07.0	9.375 [.3690]	9.610 [.3783]	9.472 [.3729]	6.200 [.2441]

- NOTES:
- ① REPRESENTS A CRITICAL DIMENSION.
 - MINIMUM PUSHOUT FORCE FOR TERMINAL, LOCKING CLIP AND WELD TAB: 2.22N [0.50LBF].
 - MAXIMUM POST HEIGHT VARIATION BETWEEN ANY TWO PINS: 0.13 [.005]
 - TEM PARTS TO BE PACKAGED IN TRAYS UNLESS OTHERWISE SPECIFIED. TEMS PARTS TO BE PACKAGED IN TAPE & REEL.
 - POSITIONS -05 THRU -20 WILL HAVE ONLY ONE SLOT PER SIDE. POSITIONS -25 THRU -40 WILL HAVE TWO SLOTS PER SIDE. POSITIONS -45 THRU -50 WILL HAVE THREE SLOTS PER SIDE.
 - SLOTS ONLY AVAILABLE IN -03.0 LEAD STYLE.
 - NOTE DELETED.
 - NOTE DELETED.
 - ORDERS WILL BE PACKAGED ACCORDING TO THE SAMTEC PACKAGING EFFICIENCY STANDARDS (SPES) FOUND ON WWW.SAMTEC.COM.
 - ATTACH LABEL -4X2 TO EACH REEL.

UNLESS OTHERWISE SPECIFIED, DIMENSIONS ARE IN MILLIMETERS.

TOLERANCES ARE:
 DECIMALS ANGLES
 X.X: ±0.3 [.01] 2°
 X.XX: ±0.13 [.005]
 X.XXX: ±0.051 [.0020]

MATERIAL: DO NOT SCALE DRAWING SHEET SCALE: 4:1

INSULATOR: LCP, COLOR: BLACK
 -L OPTION ONLY: LCP, COLOR: NATURAL

TERMINAL AND LOCKING CLIP: PHOS BRONZE 510
 WELD TAB: BRASS ALLOY 260, FULL HARD

PROPRIETARY NOTE
 THIS DOCUMENT CONTAINS CONFIDENTIAL AND PROPRIETARY INFORMATION AND ALL DESIGN, MANUFACTURING, REPRODUCTION, USE, PATENT RIGHTS AND SALES RIGHTS ARE EXPRESSLY RESERVED BY SAMTEC, INC. THIS DOCUMENT SHALL NOT BE DISCLOSED, IN WHOLE OR PART, TO ANY UNAUTHORIZED PERSON OR ENTITY NOR REPRODUCED, TRANSFERRED OR INCORPORATED IN ANY OTHER PROJECT IN ANY MANNER WITHOUT THE EXPRESS WRITTEN CONSENT OF SAMTEC, INC.

520 PARK EAST BLVD, NEW ALBANY, IN 47150
 PHONE: 812-944-6733 FAX: 812-948-5047
 e-Mail info@SAMTEC.com code 55322

DESCRIPTION:
 0.8 mm TIGER EYE MICRO TERMINAL

DWG. NO.
 TEMX-1XX-XX-XX.X-XX-D-XX-X-XX

BY: B RAY 10/18/2007 SHEET 1 OF 3

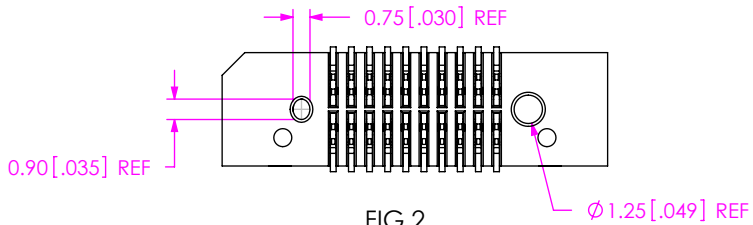
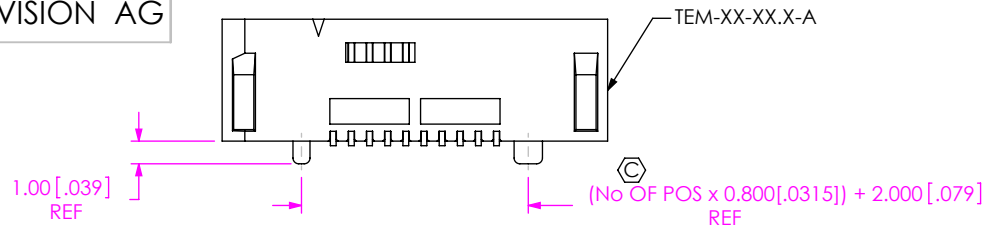

FIG 2
TEM-110-02-03.0-XX-D-A SHOWN
(SAME AS FIG 1, DIFFERENT AS SHOWN)

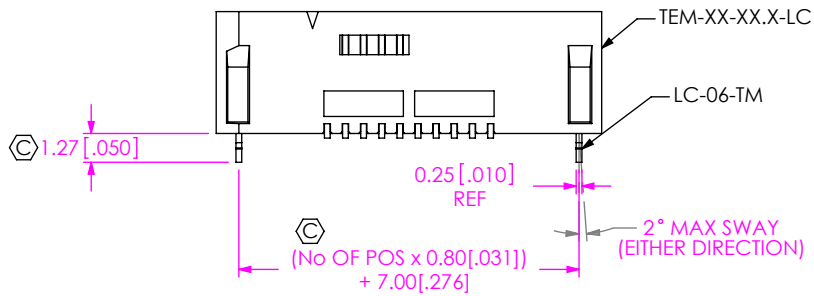

FIG 3
TEM-110-02-03.0-XX-D-LC SHOWN
(SAME AS FIG 1, DIFFERENT AS SHOWN)

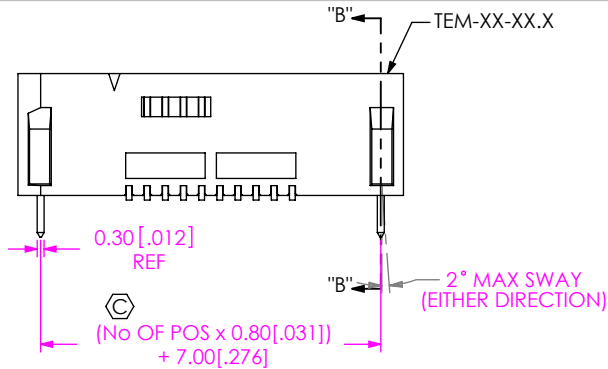
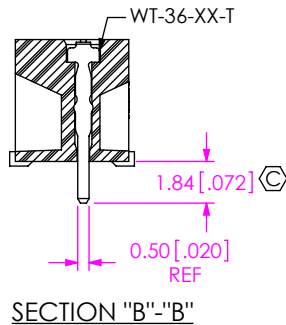

FIG 4
TEM-110-02-03.0-XX-D-WT SHOWN
(SAME AS FIG 1, DIFFERENT AS SHOWN)



SECTION "B"-"B"

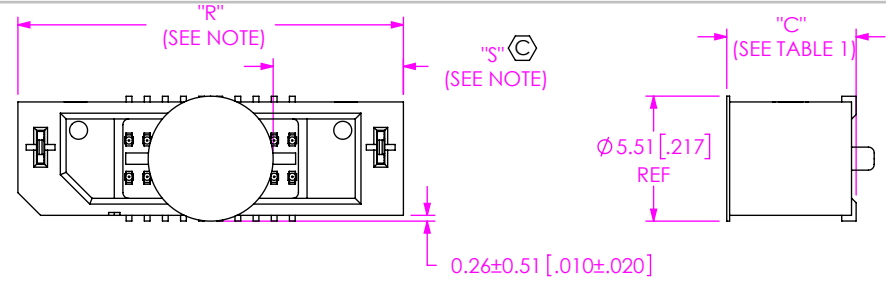

FIG 5
TEM-110-02-03.0-XX-D-K SHOWN
(SAME AS FIG 1, DIFFERENT AS SHOWN)

NOTE: "R" = OVERALL LENGTH (REF)
"S" = $\{("R" - 5.51 [.217]) / 2 [.0787]\} \pm 0.51 [.020]$

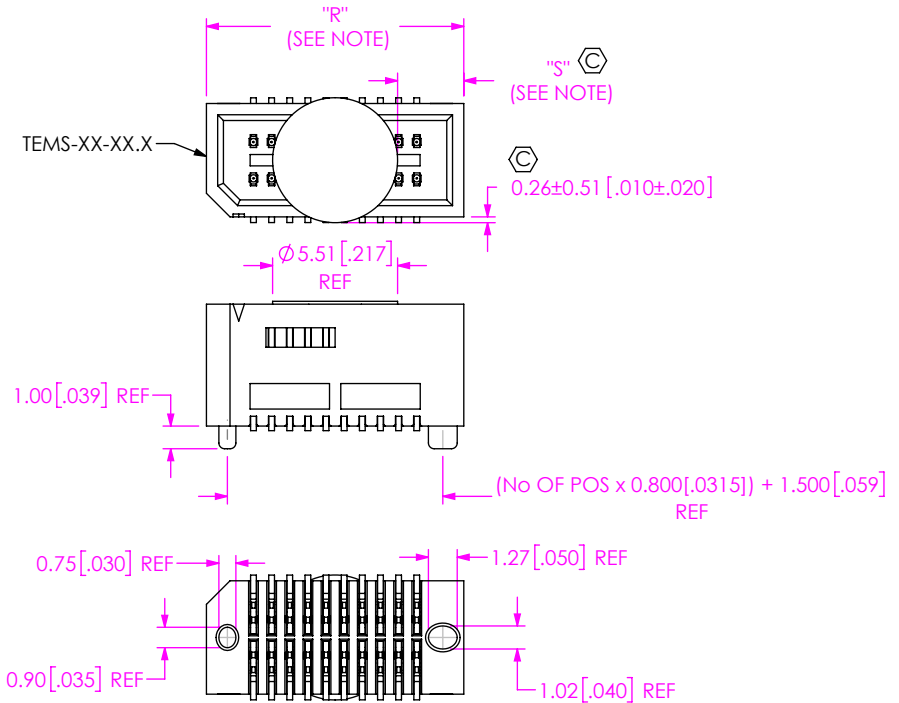

FIG 6
TEMS-110-02-03.0-XX-D-A-K SHOWN
(SAME AS FIG 1, DIFFERENT AS SHOWN)

NOTE: "R" = $((\text{No OF POS} \times 0.800) + 3.35) \pm 0.05$
"S" = $\{("R" - 5.51 [.217]) / 2 [.0787]\} \pm 0.51 [.020]$

PROPRIETARY NOTE
THIS DOCUMENT CONTAINS CONFIDENTIAL AND PROPRIETARY INFORMATION AND ALL DESIGN, MANUFACTURING, REPRODUCTION, USE, PATENT RIGHTS AND SALES RIGHTS ARE EXPRESSLY RESERVED BY SAMTEC, INC. THIS DOCUMENT SHALL NOT BE DISCLOSED, IN WHOLE OR PART, TO ANY UNAUTHORIZED PERSON OR ENTITY NOR REPRODUCED, TRANSFERRED OR INCORPORATED IN ANY OTHER PROJECT IN ANY MANNER WITHOUT THE EXPRESS WRITTEN CONSENT OF SAMTEC, INC.

DO NOT SCALE DRAWING
SHEET SCALE: 3:1



520 PARK EAST BLVD, NEW ALBANY, IN 47150
PHONE: 812-944-6733 FAX: 812-948-5047
e-Mail info@SAMTEC.com code 55322

DESCRIPTION:
0.8mm TIGER EYE MICRO TERMINAL
DWG. NO.
TEMX-1XX-XX-XX.X-XX-D-XX-X-XX
BY: B RAY 10/18/2007 SHEET 2 OF 3

TABLE 2	
STACK HEIGHT	WELD TAB
-03.0	WT-36-02-X
-04.0	WT-36-03-X
-07.0	WT-36-04-X

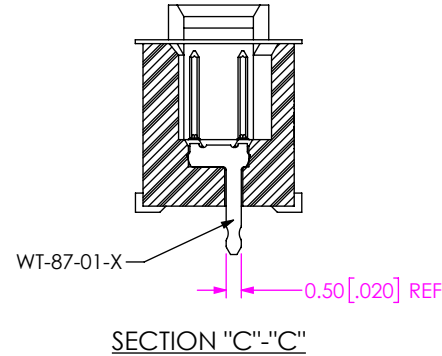
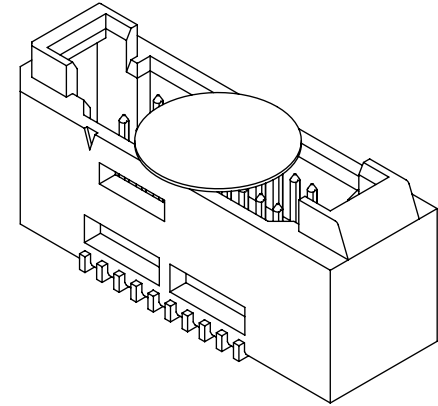
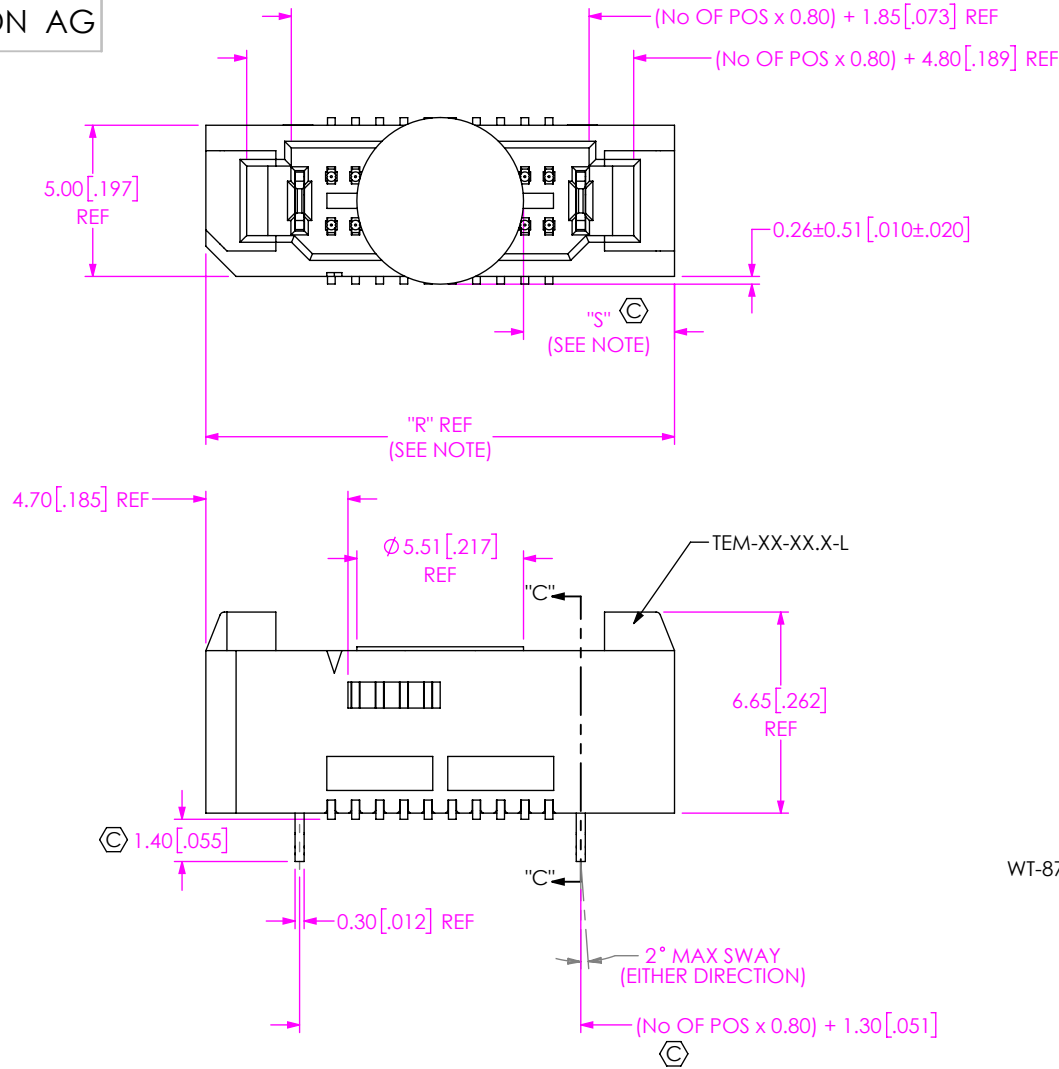

NOTE: "R" = (No OF POS x 0.80) + 7.50 [.295] REF
 "S" = {("R" - 5.51 [.217])/2} ± 0.51 [.020]

FIG 7
 TEM-1 10-02-03.0-XX-D-L1-K SHOWN
 (SAME AS FIG 1, DIFFERENT AS SHOWN)

PROPRIETARY NOTE
 THIS DOCUMENT CONTAINS CONFIDENTIAL AND PROPRIETARY INFORMATION AND ALL DESIGN, MANUFACTURING, REPRODUCTION, USE, PATENT RIGHTS AND SALES RIGHTS ARE EXPRESSLY RESERVED BY SAMTEC, INC. THIS DOCUMENT SHALL NOT BE DISCLOSED, IN WHOLE OR PART, TO ANY UNAUTHORIZED PERSON OR ENTITY NOR REPRODUCED, TRANSFERRED OR INCORPORATED IN ANY OTHER PROJECT IN ANY MANNER WITHOUT THE EXPRESS WRITTEN CONSENT OF SAMTEC, INC.

DO NOT SCALE DRAWING

SHEET SCALE: 4:1

samtec

520 PARK EAST BLVD, NEW ALBANY, IN 47150
 PHONE: 812-944-6733 FAX: 812-948-5047
 e-Mail info@SAMTEC.com code 55322



DESCRIPTION:
 0.8mm TIGER EYE MICRO TERMINAL

DWG. NO.
 TEMX-1XX-XX-XX.X-XX-D-XX-X-XX

BY: B RAY 10/18/2007 SHEET 3 OF 3

Looking for pricing, stock, or lifecycle information?

Click below to explore more details on WIN SOURCE:

-  [View TEMS-130-02-04.0-H-D-A-K-TR on WIN SOURCE](#)
-  [Samtec Inc. Information](#)

Optimize Your Supply Chain with WIN SOURCE Solutions

-  Global Sourcing Solution
-  Obsolete Management
-  Cost Control Management
-  Shortage Management
-  Alternative Solution
-  Excess Inventory Management