



# THE DATASHEET OF RMB2S



## 0.8A, 200V - 600V Fast Recovery Bridge Rectifier

### FEATURES

- AEC-Q101 qualified available
- Ideal for automated placement
- Reliable low cost construction utilizing molded plastic technique
- High surge current capability
- UL Recognized File # E-326854
- Moisture sensitivity level: level 1, per J-STD-020
- RoHS Compliant
- Halogen-free according to IEC 61249-2-21

### APPLICATIONS

- Switching mode power supply (SMPS)
- Adapters
- Lighting application

### MECHANICAL DATA

- Case: TO-269AA (MBS)
- Molding compound meets UL 94V-0 flammability rating
- Terminal: Matte tin plated leads, solderable per J-STD-002
- Meet JESD 201 class 2 whisker test
- Polarity: As marked
- Weight: 0.120g (approximately)

KEY PARAMETERS		
PARAMETER	VALUE	UNIT
$I_F$	0.8	A
$V_{RRM}$	200 - 600	V
$I_{FSM}$	30	A
$T_{J\ MAX}$	150	°C
Package	TO-269AA (MBS)	
Configuration	Quad	

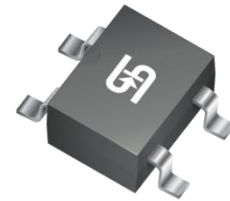

MBS

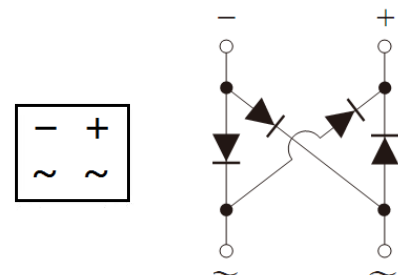

ABSOLUTE MAXIMUM RATINGS ( $T_A = 25^\circ\text{C}$ unless otherwise noted)					
PARAMETER	SYMBOL	RMB2S	RMB4S	RMB6S	UNIT
Marking code on the device		RMB2S	RMB4S	RMB6S	
Repetitive peak reverse voltage	$V_{RRM}$	200	400	600	V
Reverse voltage, total rms value	$V_{R(RMS)}$	140	280	420	V
Forward current	On glass-epoxy	$I_F$	0.5		A
	On aluminum substrate		0.8		A
Surge peak forward current, 8.3ms single half sine-wave superimposed on rated load	$I_{FSM}$	30		A	
Rating for fusing ( $t < 8.3\text{ms}$ )	$I^2t$	3.74		$\text{A}^2\text{s}$	
Junction temperature	$T_J$	- 55 to +150		°C	
Storage temperature	$T_{STG}$	- 55 to +150		°C	

<b>THERMAL PERFORMANCE</b>			
<b>PARAMETER</b>	<b>SYMBOL</b>	<b>TYP</b>	<b>UNIT</b>
Junction-to-ambient thermal resistance	$R_{\theta JA}$	85	°C/W

<b>ELECTRICAL SPECIFICATIONS</b> ( $T_A = 25^\circ\text{C}$ unless otherwise noted)					
<b>PARAMETER</b>	<b>CONDITIONS</b>	<b>SYMBOL</b>	<b>TYP</b>	<b>MAX</b>	<b>UNIT</b>
Forward voltage per diode <sup>(1)</sup>	$I_F = 0.4\text{A}, T_J = 25^\circ\text{C}$	$V_F$	-	1	V
Reverse current @ rated $V_R$ per diode <sup>(2)</sup>	$T_J = 25^\circ\text{C}$	$I_R$	-	5	$\mu\text{A}$
	$T_J = 125^\circ\text{C}$		-	100	$\mu\text{A}$
Junction capacitance per diode	1MHz, $V_R = 4.0\text{V}$	$C_J$	13	-	pF
Reverse recovery time	$I_F = 0.5\text{A}, I_R = 1.0\text{A}$ $I_{rr} = 0.25\text{A}$	$t_{rr}$	-	150	ns

**Notes:**

1. Pulse test with PW = 0.3ms
2. Pulse test with PW = 30ms

<b>ORDERING INFORMATION</b>		
<b>ORDERING CODE</b> <sup>(1)(2)</sup>	<b>PACKAGE</b>	<b>PACKING</b>
RMBxS	TO-269AA (MBS)	3,000 / Tape & Reel
RMBxSH	TO-269AA (MBS)	3,000 / Tape & Reel

**Notes:**

1. "x" defines voltage from 200V(RMB2S) to 600V(RMB6S)
2. "H" means AEC-Q101 qualified

**CHARACTERISTICS CURVES**

( $T_A = 25^\circ\text{C}$  unless otherwise noted)

**Fig.1 Forward Current Derating Curve**

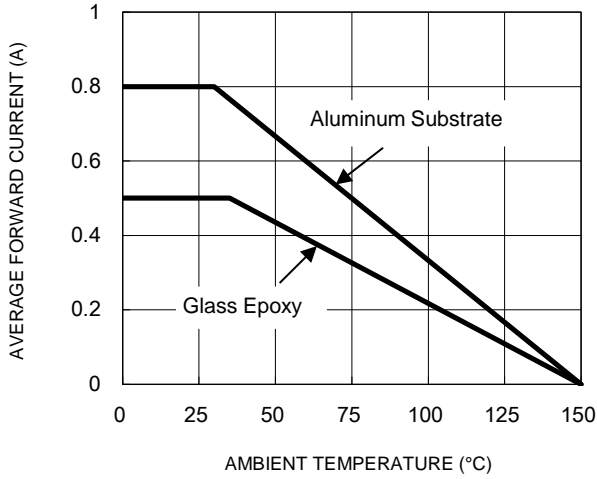

**Fig.2 Typical Junction Capacitance**

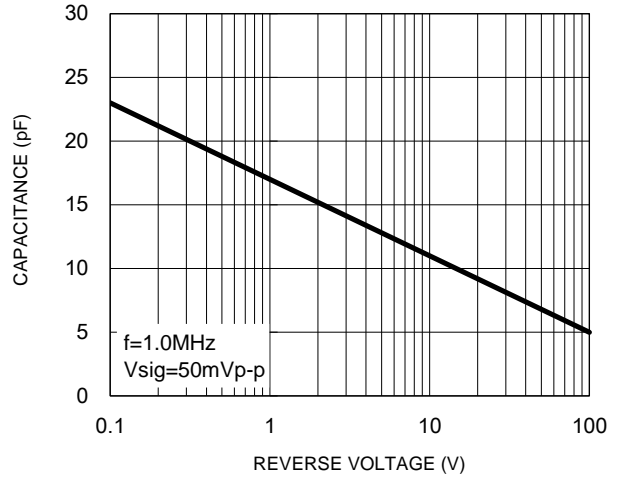

**Fig.3 Typical Reverse Characteristics**

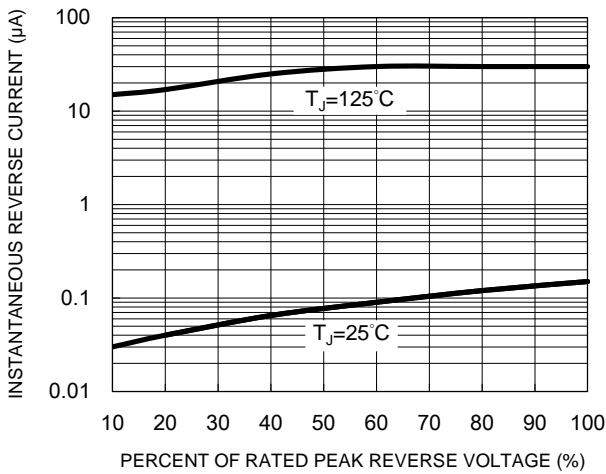

**Fig.4 Typical Forward Characteristics**

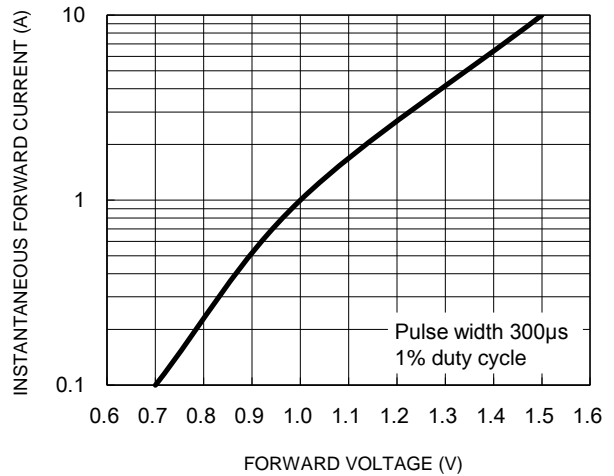

**Fig.5 Maximum Non-Repetitive Forward Surge Current**

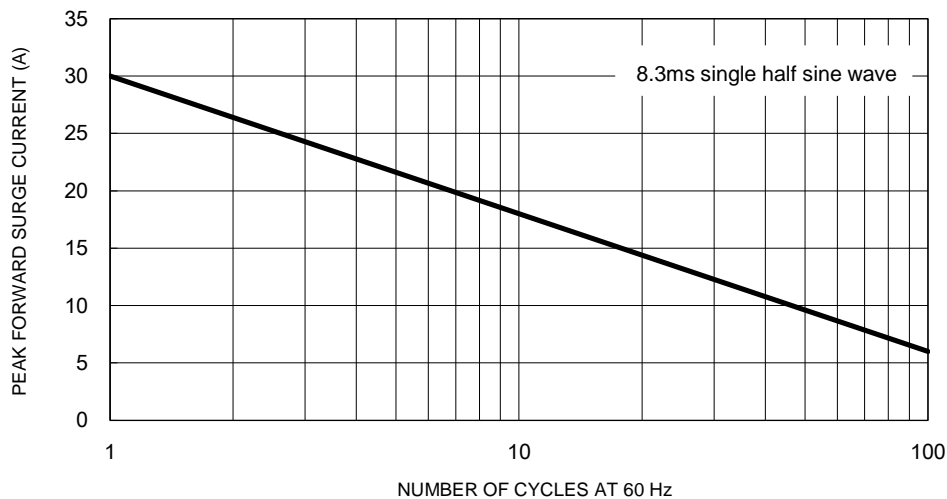

**CHARACTERISTICS CURVES**

( $T_A = 25^\circ\text{C}$  unless otherwise noted)

**Fig.6 Reverse Recovery Time Characteristic and Test Circuit Diagram**



**PACKAGE OUTLINE DIMENSIONS**

TO-269AA (MBS)

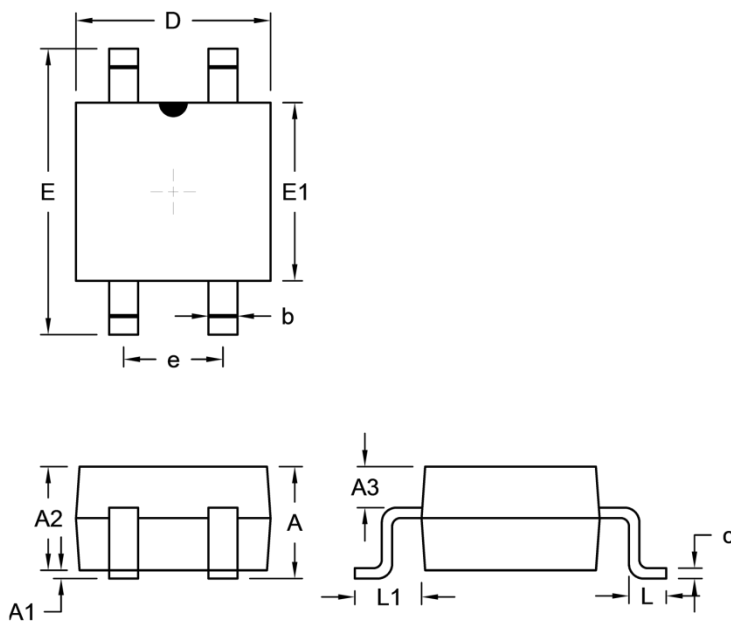

DIM.	Unit (mm)		Unit (inch)	
	Min.	Max.	Min.	Max.
A	-	2.90	-	0.114
A1	-	0.20	-	0.008
A2	2.30	2.70	0.091	0.106
A3	0.95	1.53	0.037	0.060
b	0.56	0.84	0.022	0.033
c	0.15	0.35	0.006	0.014
D	4.50	4.90	0.177	0.193
E	-	6.90	-	0.272
E1	3.60	5.00	0.142	0.197
e	2.20	2.60	0.087	0.102
L	0.70	1.10	0.028	0.043
L1	1.10	2.12	0.043	0.083

**SUGGESTED PAD LAYOUT**

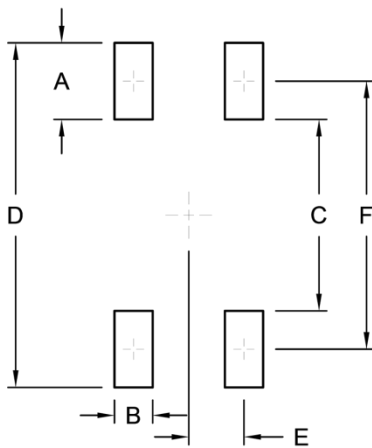

Symbol	Unit (mm)	Unit (inch)
A	1.80	0.071
B	0.90	0.035
C	4.50	0.177
D	8.10	0.319
E	1.30	0.051
F	6.30	0.248

**MARKING DIAGRAM**



P/N = Marking Code  
YW = Date Code  
F = Factory Code

## **Notice**

Specifications of the products displayed herein are subject to change without notice. TSC or anyone on its behalf, assumes no responsibility or liability for any errors or inaccuracies.



Purchasers are solely responsible for the choice, selection, and use of TSC products and TSC assumes no liability for application assistance or the design of Purchasers' products.

Information contained herein is intended to provide a product description only. No license, express or implied, to any intellectual property rights is granted by this document. Except as provided in TSC's terms and conditions of sale for such products, TSC assumes no liability whatsoever, and disclaims any express or implied warranty, relating to sale and/or use of TSC products including liability or warranties relating to fitness for a particular purpose, merchantability, or infringement of any patent, copyright, or other intellectual property right.

The products shown herein are not designed for use in medical, life-saving, or life-sustaining applications. Customers using or selling these products for use in such applications do so at their own risk and agree to fully indemnify TSC for any damages resulting from such improper use or sale.

## Looking for pricing, stock, or lifecycle information?

Click below to explore more details on WIN SOURCE:

-  [View RMB2S on WIN SOURCE](#)
-  [Taiwan Semiconductor Information](#)

## Optimize Your Supply Chain with WIN SOURCE Solutions

-  Global Sourcing Solution
-  Obsolete Management
-  Cost Control Management
-  Shortage Management
-  Alternative Solution
-  Excess Inventory Management