

OnBoard 868/915/868+2400 MHz - Antenna

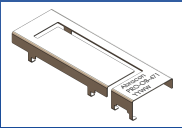

PRO-OB-471

Request Samples



Check Inventory



34.00 x 11.53 x 4.93 mm
RoHS/RoHS II Compliant
MSL Level = 1

Features

- Supports 868, 915 or 868+2400 MHz
- Profile of 4.93 mm
- Mixed Linear Polarization
- Surface Mount
- Durable-Shelf life of upto 10 years
- Three different evaluation boards available:
 - “SMD 868” for 860-870 MHz
 - “SMD 915” for 902-928 MHz
 - “SMD 868+2400” for 860-870 + 2400-2500 MHz

Applications

- Wi-Fi/BT/LPWA/LoRA/SigFox/ISM
- IoT, M2M
 - Industrial
 - Infrastructure
 - Medical
- Remote Technology / Monitoring
- Network devices
- Consumer Tracking
- Smart Metering

Product Image

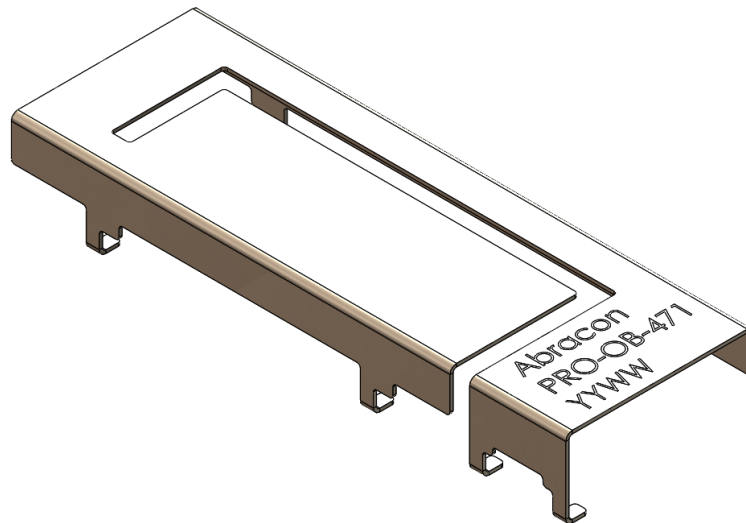

5101 Hidden Creek Ln Spicewood TX 78669
Phone: 512-371-6159 | Fax: 512-351-8858
For terms and conditions of sales, please visit:
www.abracon.com

REVISED:

ABRACON IS
ISO9001-2015
CERTIFIED

OnBoard 868/915/868+2400 MHz - Antenna

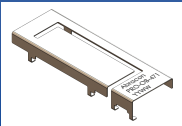

PRO-OB-471

Request Samples



Check Inventory



34.00 x 11.53 x 4.93 mm
RoHS/RoHS II Compliant
MSL Level = 1

Electrical Specification

Parameter	Specification				Unit
	"SMD 868"	"SMD 915"	"SMD 868+2400"		
Operating Frequency	860 - 870	902 - 928	860 - 870	2400 - 2500	MHz
Center Frequency	865	915	865	2450	
Return Loss	< -9.9	< -6.6	< -8.3	< -4.3 dB	dB
Polarization	Mixed Linear				
Peak Gain	1.7	2.4	1	3.8	dBi
Efficiency	> 63	> 50	> 49	> 43	%
Impedance	50				Ω

Note: All measurements were conducted on its evaluation board in free space. Performance will vary depending on the ground plane, application, and environment.

Mechanical Specification

Parameter	Specification
Antenna Dimension	34.00 x 11.53 x 4.93 mm
Evaluation board Dimension "SMD 868"	120 x 50 mm
Evaluation board Dimension "SMD 915"	120 x 50 mm
Evaluation board Dimension "SMD 868+2400"	95 x 38 mm
Mounting Type	Surface Mount

Environmental Specification

Parameter	Specification
Operating Temperature	-40°C to +125°C
Storage Temperature	
Maximum Temperature	
RoHS Compliance	Yes Compliant with EU directive 2011/65/EU and 2015/863
Shelf life	10 years
MSL	Level 1, unlimited
Mechanical resistance	Immunity to vibrations IEC/EN 60068-2-6, Fc test Immunity to shock IEC/EN 60068-2-27, Ea test



5101 Hidden Creek Ln Spicewood TX 78669
Phone: 512-371-6159 | Fax: 512-351-8858
For terms and conditions of sales, please visit:
www.abracon.com

REVISED:

ABRACON IS
ISO9001-2015
CERTIFIED

OnBoard 868/915/868+2400 MHz - Antenna

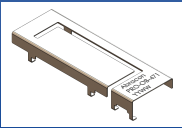

PRO-OB-471

Request Samples



Check Inventory



34.00 x 11.53 x 4.93 mm
RoHS/RoHS II Compliant
MSL Level = 1

Product Dimension

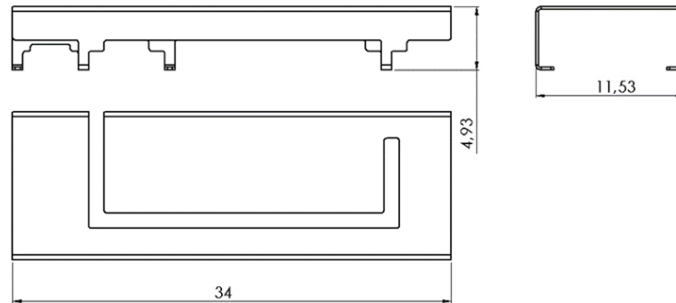

Unit : mm

Antenna pins and keep-out block

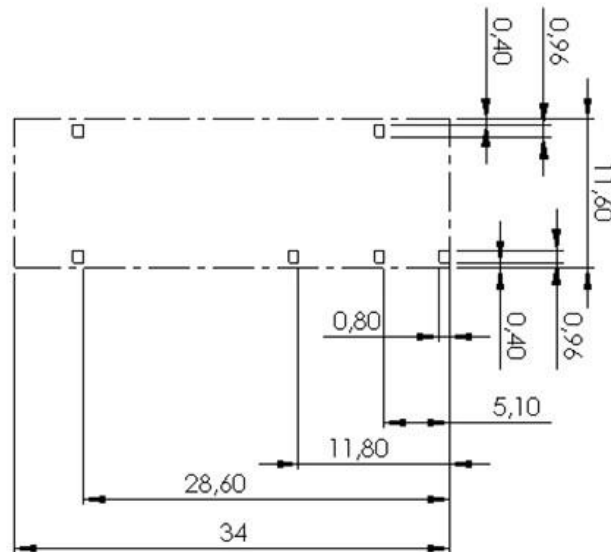

Unit : mm

OnBoard 868/915/868+2400 MHz - Antenna

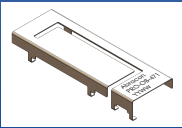

PRO-OB-471

Request Samples



Check Inventory



34.00 x 11.53 x 4.93 mm
RoHS/RoHS II Compliant
MSL Level = 1

PCB layout and antenna pin numbering

The antenna uses PIFA technology and should thus be mounted on a ground plane. If there are several layers in the PCB, there is an advantage to add vias for smooth interconnection of the ground areas to avoid splits in the ground plane. It is also important that there is a ground clearance around the NC pads and the RF feed pad, through all layers of the PCB. It is recommended to implement a matching network to optimize the antenna impedance in your application. The components can be positioned under the antenna. See recommendations in the figures below.

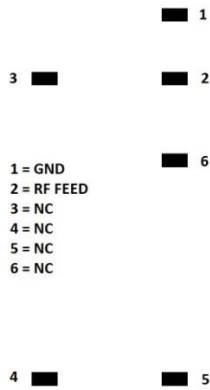

Pin configuration



PCB Layout (from evaluation board)

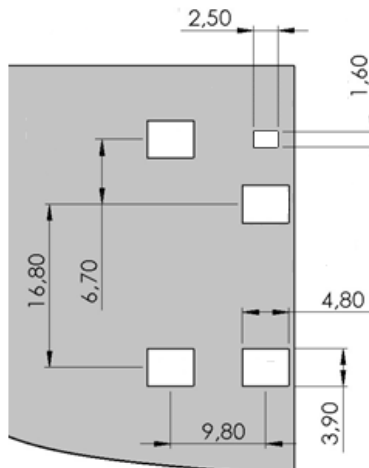
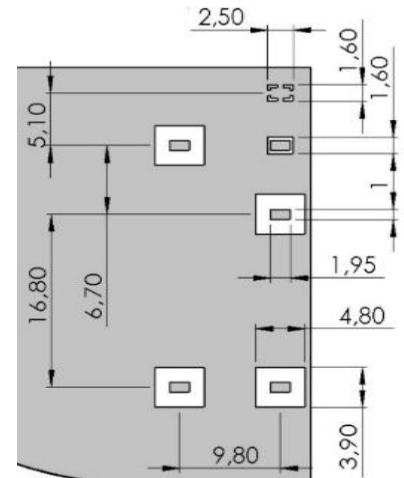

Clearance through all layers

Unit: mm



5101 Hidden Creek Ln Spicewood TX 78669
 Phone: 512-371-6159 | Fax: 512-351-8858
 For terms and conditions of sales, please visit:
www.abracon.com

REVISED:

ABRACON IS
 ISO9001-2015
 CERTIFIED

OnBoard 868/915/868+2400 MHz - Antenna

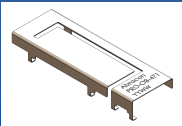

PRO-OB-471

Request Samples



Check Inventory



34.00 x 11.53 x 4.93 mm
RoHS/RoHS II Compliant
MSL Level = 1

Measurement Setup

The antenna measurements for 868 MHz were done with the OnBoard “SMD 868” evaluation board (PRO-EB-472, 120 x 50 mm) - measured in free space.

The antenna measurements for 915 MHz were done with the OnBoard “SMD 915” evaluation board (PRO-EB-476, 120 x 50 mm) - measured in free space.

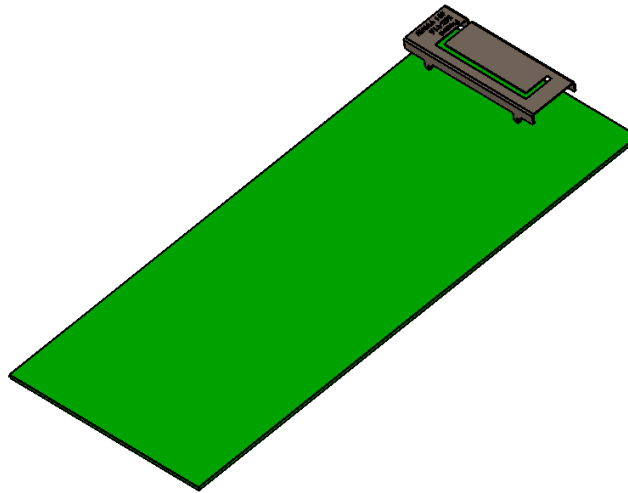

The antenna measurements for 868+2400 MHz were done with the OnBoard “SMD 868+2400” evaluation board (PRO-EB-531, 95 x 38 mm) - measured in free space.

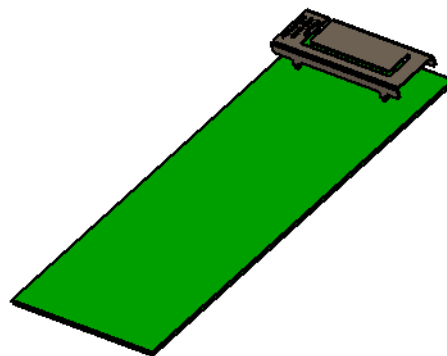

OnBoard 868/915/868+2400 MHz - Antenna

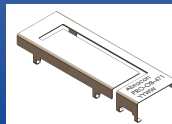

PRO-OB-471

Request Samples



Check Inventory



34.00 x 11.53 x 4.93 mm
RoHS/RoHS II Compliant
MSL Level = 1

Reflection Characteristics “SMD 868” – Return Loss

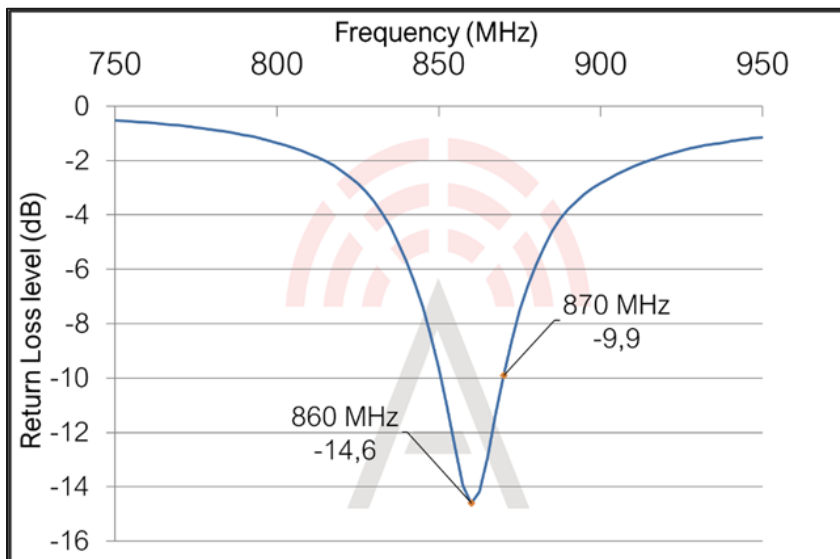

Total Radiation Efficiency “SMD 868”

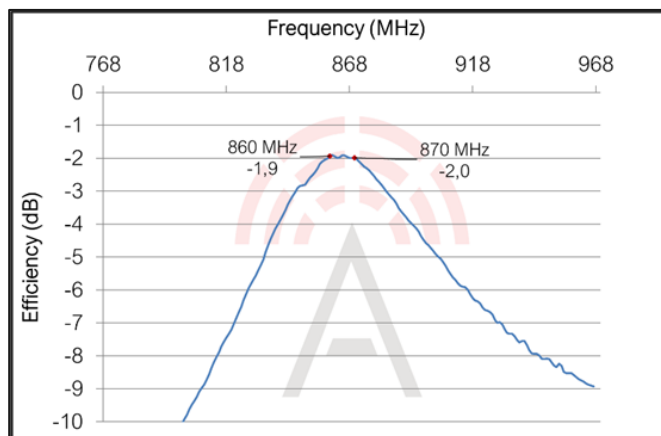

Maximum Radiation Gain “SMD 868”

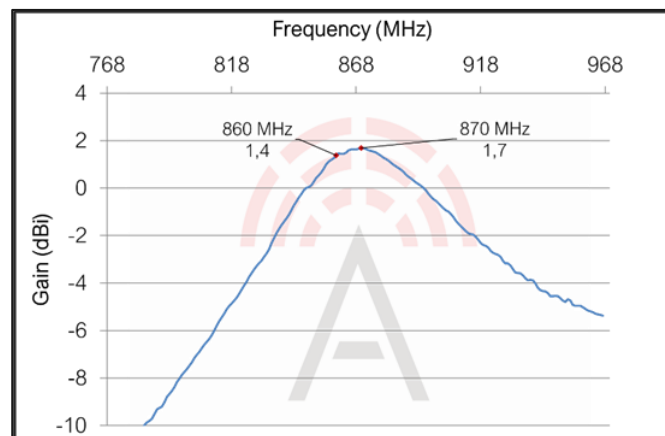

5101 Hidden Creek Ln Spicewood TX 78669
Phone: 512-371-6159 | Fax: 512-351-8858
For terms and conditions of sales, please visit:
www.abracon.com

REVISED:

ABRACON IS
ISO9001-2015
CERTIFIED

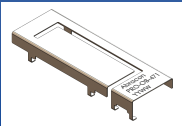

PRO-OB-471

Request Samples



Check Inventory



34.00 x 11.53 x 4.93 mm
RoHS/RoHS II Compliant
MSL Level = 1

Reflection Characteristics “SMD 915” – Return Loss

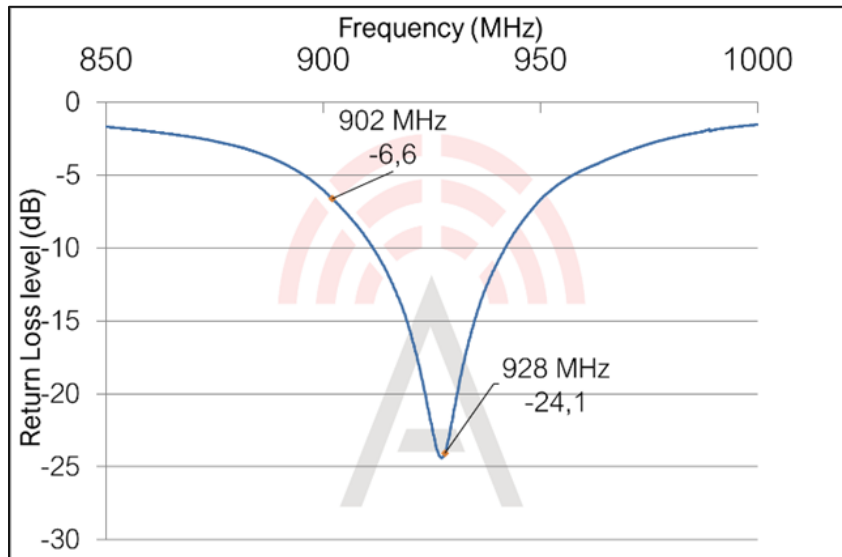

Total Radiation Efficiency “SMD 915”

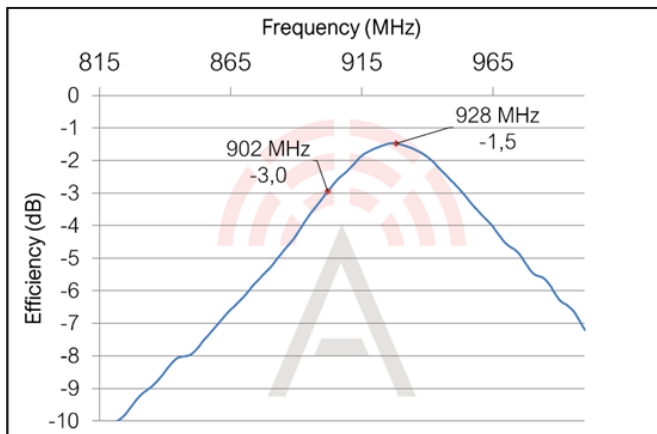

Maximum Radiation Gain “SMD 915”

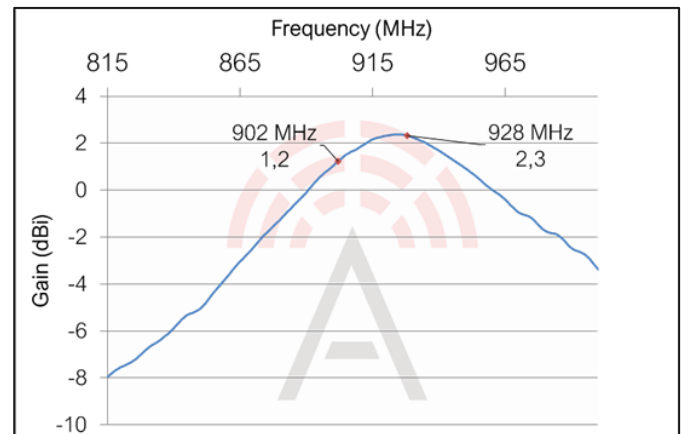

OnBoard 868/915/868+2400 MHz - Antenna

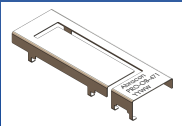

PRO-OB-471

Request Samples



Check Inventory



34.00 x 11.53 x 4.93 mm
RoHS/RoHS II Compliant
MSL Level = 1

Reflection Characteristics “SMD 868+2400” – Return Loss

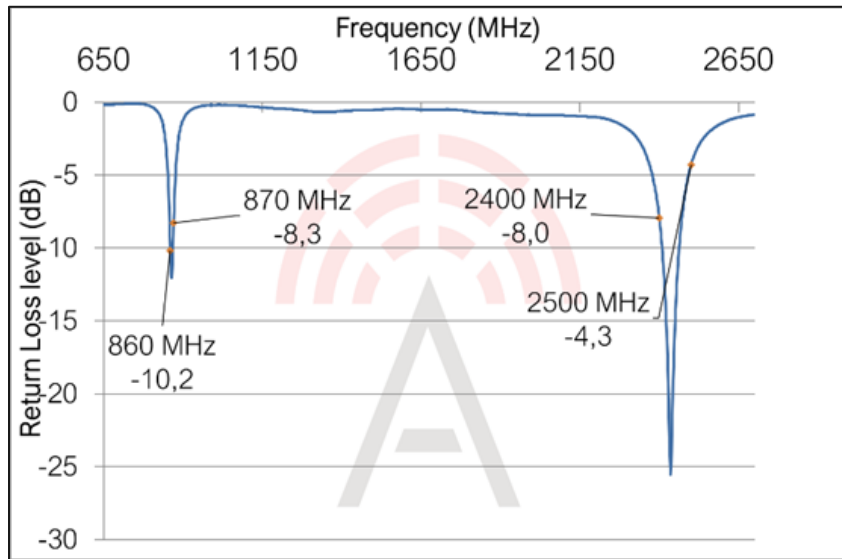

Total Radiation Efficiency “SMD 868+2400”

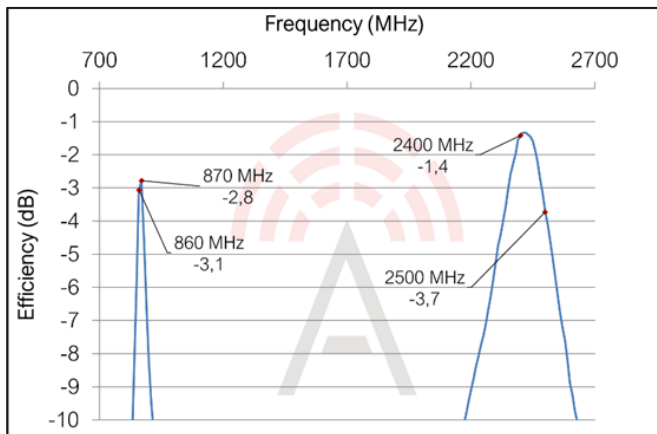

Maximum Radiation Gain “SMD 868+2400”

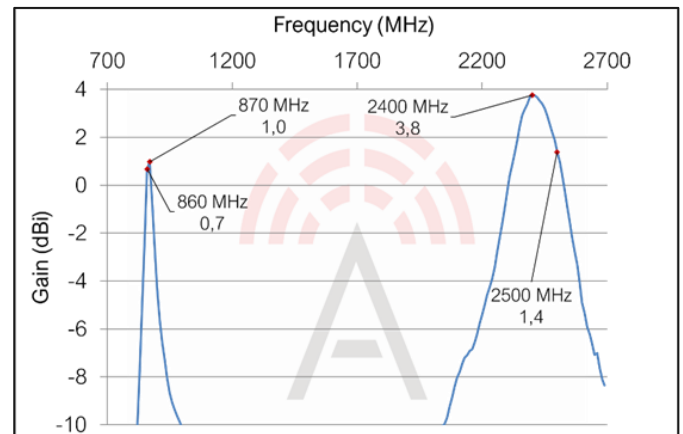

5101 Hidden Creek Ln Spicewood TX 78669
Phone: 512-371-6159 | Fax: 512-351-8858
For terms and conditions of sales, please visit:
www.abracon.com

REVISED:

ABRACON IS
ISO9001-2015
CERTIFIED

OnBoard 868/915/868+2400 MHz - Antenna

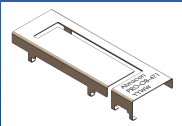

PRO-OB-471

Request Samples



Check Inventory



34.00 x 11.53 x 4.93 mm
RoHS/RoHS II Compliant
MSL Level = 1

Radiation Characteristics – 2D Pattern “SMD 868” at 868 MHz

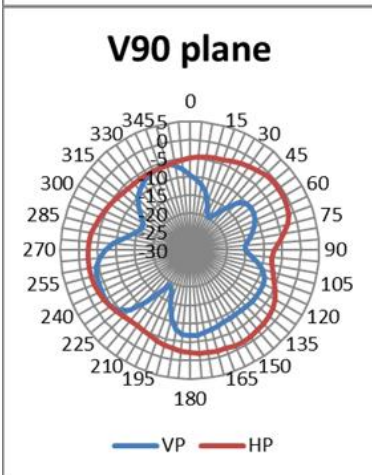
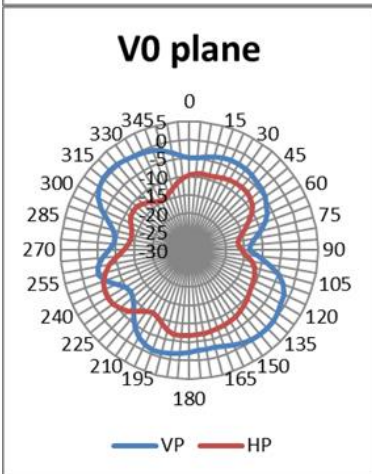
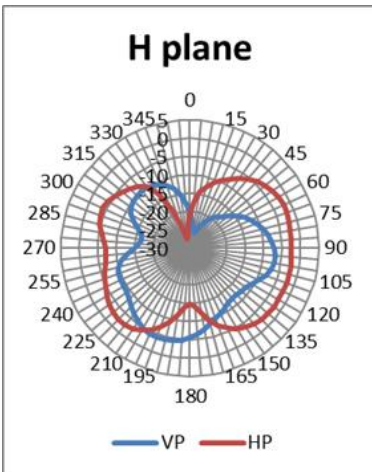

VP: Vertical Polarization
HP: Horizontal Polarization

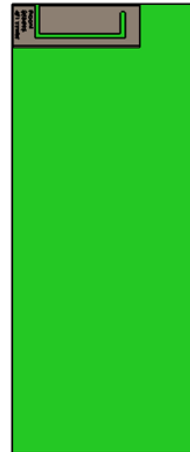

Unit: dBi



5101 Hidden Creek Ln Spicewood TX 78669
Phone: 512-371-6159 | Fax: 512-351-8858
For terms and conditions of sales, please visit:
www.abracon.com

REVISED:

ABRACON IS
ISO9001-2015
CERTIFIED

OnBoard 868/915/868+2400 MHz - Antenna

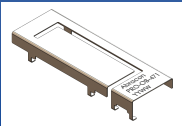

PRO-OB-471

Request Samples



Check Inventory



34.00 x 11.53 x 4.93 mm
RoHS/RoHS II Compliant
MSL Level = 1

Radiation Characteristics – 2D Pattern “SMD 915” at 915 MHz

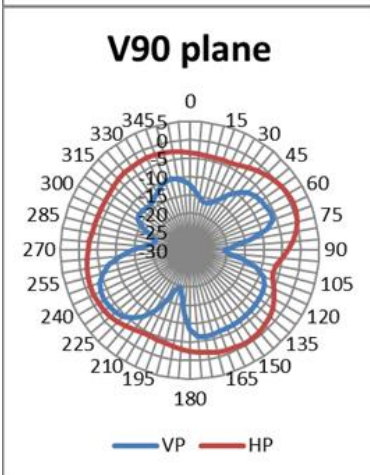
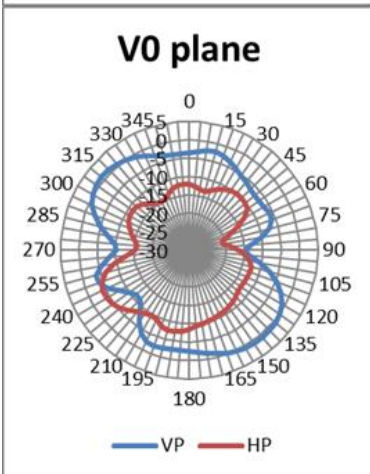
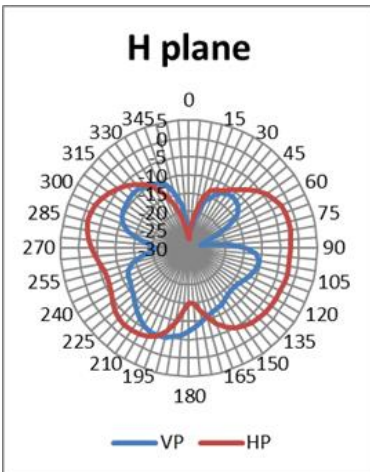

VP: Vertical Polarization
HP: Horizontal Polarization

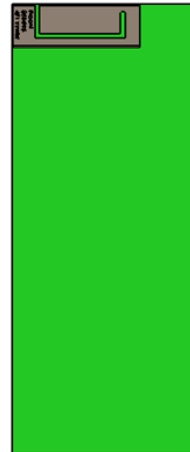

Unit: dBi



5101 Hidden Creek Ln Spicewood TX 78669
Phone: 512-371-6159 | Fax: 512-351-8858
For terms and conditions of sales, please visit:
www.abracon.com

REVISED:

ABRACON IS
ISO9001-2015
CERTIFIED

OnBoard 868/915/868+2400 MHz - Antenna

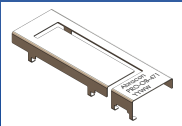

PRO-OB-471

Request Samples



Check Inventory



34.00 x 11.53 x 4.93 mm
RoHS/RoHS II Compliant
MSL Level = 1

Radiation Characteristics – 2D Pattern “SMD 868+2400” at 868 MHz

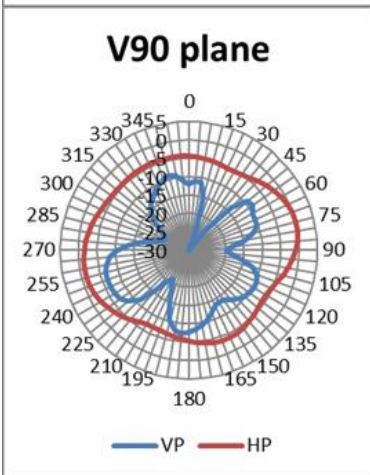
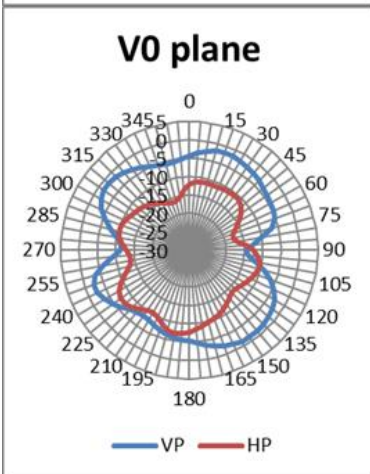
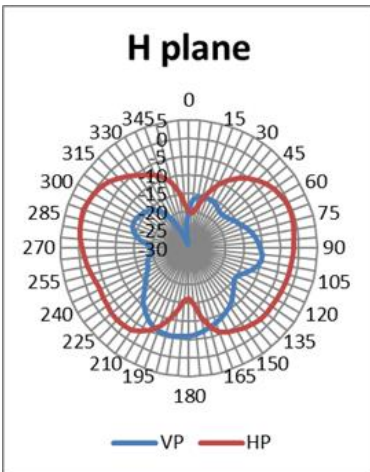

VP: Vertical Polarization
HP: Horizontal Polarization



Unit: dBi



5101 Hidden Creek Ln Spicewood TX 78669
Phone: 512-371-6159 | Fax: 512-351-8858
For terms and conditions of sales, please visit:
www.abracon.com

REVISED:

ABRACON IS
ISO9001-2015
CERTIFIED

OnBoard 868/915/868+2400 MHz - Antenna

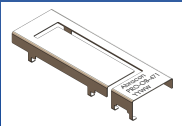

PRO-OB-471

Request Samples



Check Inventory



34.00 x 11.53 x 4.93 mm
 RoHS/RoHS II Compliant
 MSL Level = 1

Radiation Characteristics – 2D Pattern “SMD 868+2400” at 2400 MHz

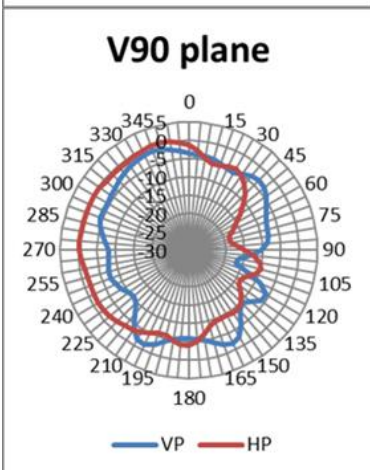
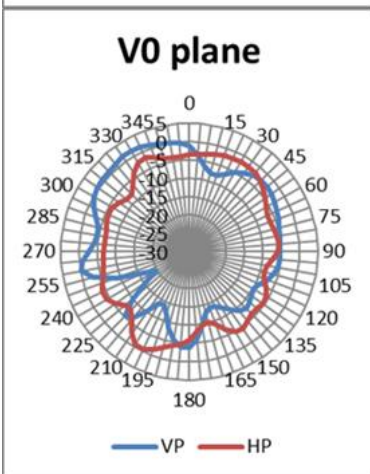
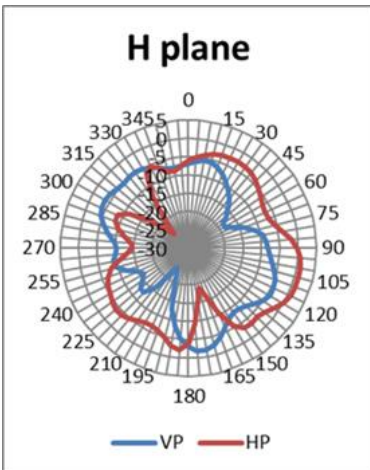

VP: Vertical Polarization
 HP: Horizontal Polarization



Unit: dBi



5101 Hidden Creek Ln Spicewood TX 78669
 Phone: 512-371-6159 | Fax: 512-351-8858
 For terms and conditions of sales, please visit:
www.abracon.com

REVISED:

ABRACON IS
 ISO9001-2015
 CERTIFIED

OnBoard 868/915/868+2400 MHz - Antenna

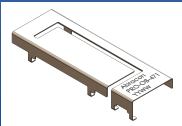

PRO-OB-471

Request Samples



Check Inventory



34.00 x 11.53 x 4.93 mm
RoHS/RoHS II Compliant
MSL Level = 1

Radiation Characteristics – 2D Pattern “SMD 868+2400” at 2500 MHz

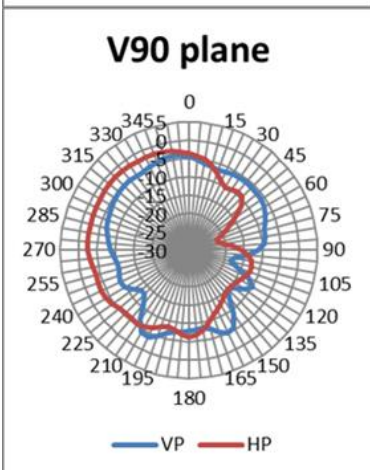
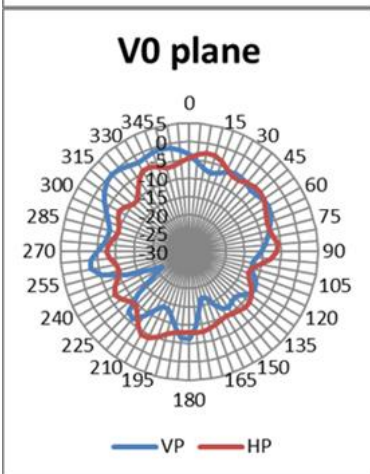
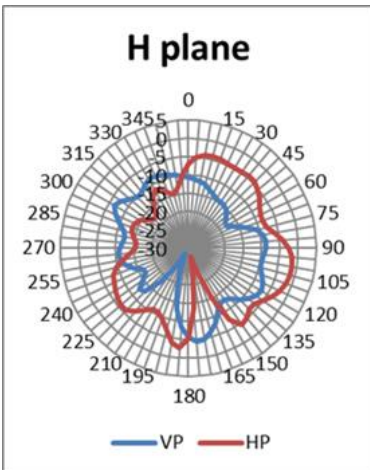

VP: Vertical Polarization
HP: Horizontal Polarization



Unit: dBi



5101 Hidden Creek Ln Spicewood TX 78669
Phone: 512-371-6159 | Fax: 512-351-8858
For terms and conditions of sales, please visit:
www.abracon.com

REVISED:

ABRACON IS
ISO9001-2015
CERTIFIED

OnBoard 868/915/868+2400 MHz - Antenna

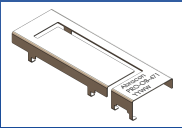

PRO-OB-471

Request Samples



Check Inventory



34.00 x 11.53 x 4.93 mm
RoHS/RoHS II Compliant
 MSL Level = 1

Evaluation Board Outline & Matching Circuit (“SMD 868” or “SMD 915”)

The evaluation board is developed to simplify antenna (PRO-OB-471) testing and evaluation. It has an arbitrary size of 120 x 50 mm and includes an SMA connector. The purpose is to give a reference design for an optimal antenna implementation. The evaluation board can also be used to test other implementations by cutting and soldering the PCB into any device. For this antenna the evaluation board is available with three different tuning options, two of which is:

1. Evaluation board “SMD 868” (PRO-EB-472) for 860-870 MHz operation
2. Evaluation board “SMD 915” (PRO-EB-476) for 902-928 MHz operation.



Evaluation board outline

The evaluation board has a matching circuit implemented next to the antenna. This is aimed to enable optimization possibilities for the user. The component positions are sized for 0402 (1005 metric) SMD components.

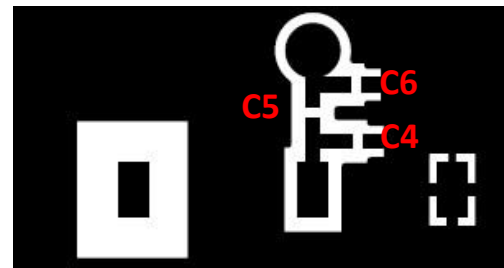
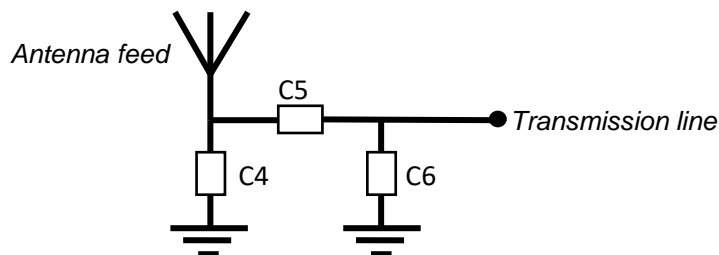

Matching circuit

The antenna needs a matching circuit to adjust the resonant frequency balance. When delivered, the evaluation board is tuned for optimum balance for 868 MHz or 915 MHz using the following (can be replaced by equivalent):

Component	“SMD 868” (PRO-EB-472)	“SMD 915” (PRO-EB-476)
C4	N/A	N/A
C5	5.6 pF (Murata GJM1555C1H5R6WB01)	1.5 nH (Murata LQW15AN1N5B00)
C6	2.2 pF (Murata GJM1555C1H2R2WB01)	5.6 pF (Murata GJM1555C1H5R6WB01)

However, it is common that the resonant frequency will shift during implementation in an arbitrary device. Therefore, this matching may be changed with other values/components/brands for compensation of such effects. This is further described in General Implementation Guidelines section below.

OnBoard 868/915/868+2400 MHz - Antenna

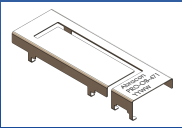

PRO-OB-471

Request Samples



Check Inventory



34.00 x 11.53 x 4.93 mm
RoHS/RoHS II Compliant
MSL Level = 1

Evaluation Board Outline & Matching Circuit (“SMD 868+2400”)

The evaluation board is developed to simplify antenna (PRO-OB-471) testing and evaluation. It has an arbitrary size of 120 x 50 mm and includes an SMA connector. The purpose is to give a reference design for an optimal antenna implementation. The evaluation board can also be used to test other implementations by cutting and soldering the PCB into any device. For this antenna the evaluation board is available with three different tuning options, the third one is:

3. Evaluation board “SMD 868+2400” (PRO-EB-531) for 860 - 870 MHz and 2.4 - 2.5 GHz operation.

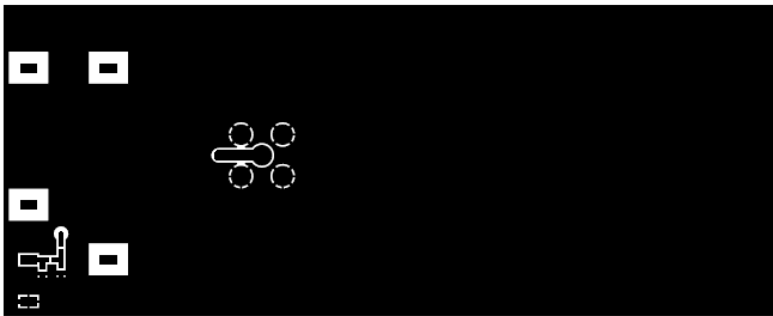

Evaluation board outline

The evaluation board has a matching circuit implemented next to the antenna. This is aimed to enable optimization possibilities for the user. The component positions are sized for 0402 (1005 metric) SMD components.

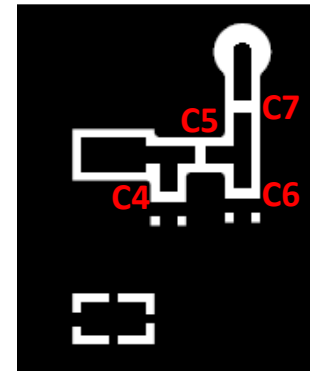
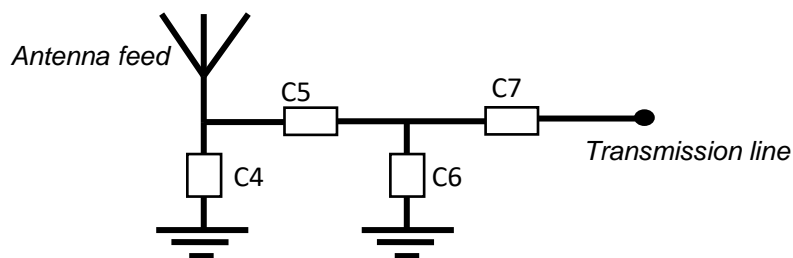

Matching circuit

The antenna needs a matching circuit to adjust the resonant frequency balance. When delivered, the evaluation board is tuned for optimum balance for 868 MHz and 2400 MHz using the following (can be replaced by equivalent):

Component	“SMD 868+2400” (PRO-EB-531)
C4	0.6 pF (Murata GJM1555C1HR60WB01)
C5	2.2 pF (Murata GJM1555C1H2R2WB01)
C6	0.7 pF (Murata GJM1555C1HR70WB01)
C7	0 Ω

However, it is common that the resonant frequency will shift during implementation in an arbitrary device. Therefore, this matching may be changed with other values/components/brands for compensation of such effects. This is further described in General Implementation Guidelines section below.



5101 Hidden Creek Ln Spicewood TX 78669
Phone: 512-371-6159 | Fax: 512-351-8858
For terms and conditions of sales, please visit:
www.abracon.com

REVISED:

ABRACON IS
ISO9001-2015
CERTIFIED

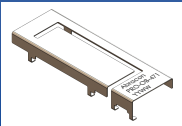

PRO-OB-471

Request Samples



Check Inventory



34.00 x 11.53 x 4.93 mm
RoHS/RoHS II Compliant
MSL Level = 1

General Implementation Guidelines

The antenna can be positioned in different ways, although there are some positions which are more beneficial. Below picture shows a typical PCB with examples on different antenna positions. The optimal position is option 1 or 4.

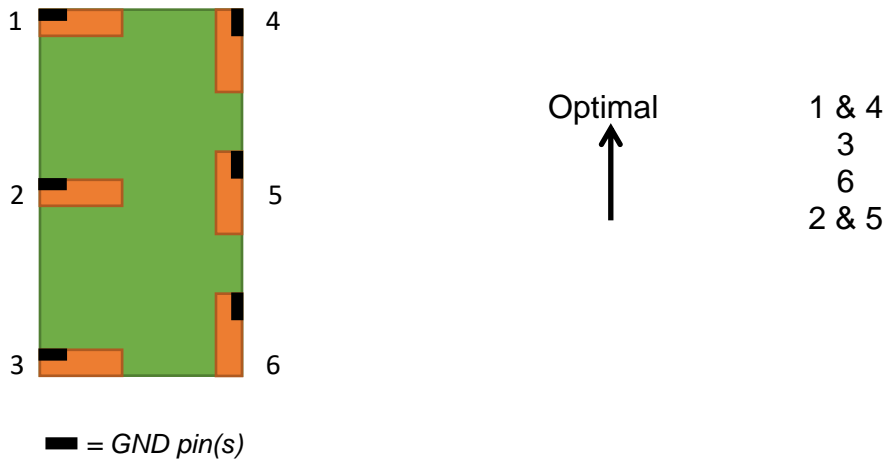

The antenna should be aligned with the PCB edge if possible, preferably with the GND pin(s) close to a corner.

The antenna enables that small electrical components are mounted inside the antenna keep-out block. This is a space-efficient solution which has very little influence on the performance. It may have an impact on the antenna tuning, but is fully possible if there is limited space on the PCB.

Another general aspect on surface mounted antennas is regarding the PCB population. If other electrical components are positioned in the surrounding area of the antenna, some impact on the antenna tuning and radiated performance may be expected. It is recommended that such components are distributed below a topographical slope that starts on PCB level at the antenna keep-out block, and slowly increases the height.

It shall also be highlighted that plastic and metal parts in the near proximity of antennas may influence the antenna tuning and/or performance. This aspect should be noted as a general guideline for all antennas. The effects are difficult to estimate without detailed information, but it is common that a plastic housing above the antenna shifts the resonant frequency down. It is recommended to measure the antenna in the actual device after implementation.

OnBoard 868/915/868+2400 MHz - Antenna

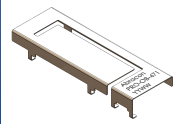

PRO-OB-471

Request Samples



Check Inventory



34.00 x 11.53 x 4.93 mm
RoHS/RoHS II Compliant
MSL Level = 1

Packaging

The antenna is delivered on tape and reel according to following specifications. The quantity per 13" reel is 250 pcs.

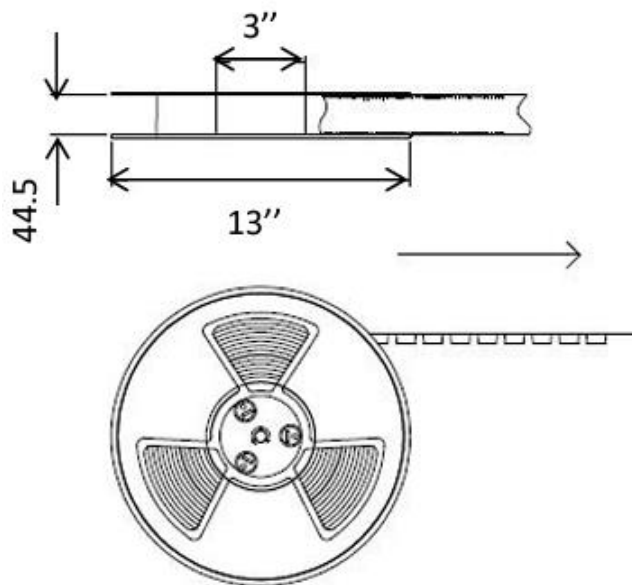
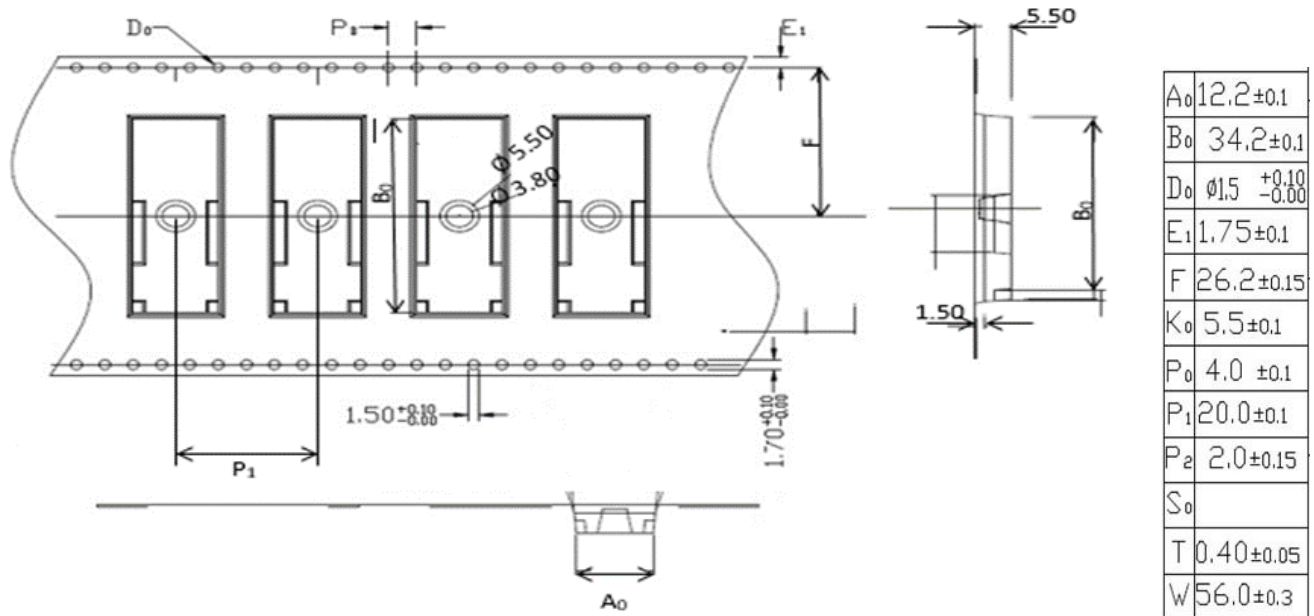

- 10 sprocket hole pitch cumulative tolerance ±0.2
- Camber not to exceed 1mm in 100m
- A₀ and B₀ measured on a plane 0.35mm above the bottom of the pocket
- K₀ measured from a plane on the inside bottom of the Pocket to the top surface of the carrier
- Pocket position relative to sprocket hole measured as true position of pocket, not pocket hole
- Component load per 13" reel: 250 pcs

Unit: mm (unless otherwise noted)



5101 Hidden Creek Ln Spicewood TX 78669
 Phone: 512-371-6159 | Fax: 512-351-8858
 For terms and conditions of sales, please visit:
www.abracon.com

REVISED:

ABRACON IS
 ISO9001-2015
 CERTIFIED

OnBoard 868/915/868+2400 MHz - Antenna

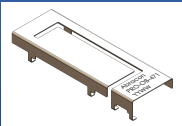

PRO-OB-471

Request Samples



Check Inventory



34.00 x 11.53 x 4.93 mm
RoHS/RoHS II Compliant
 MSL Level = 1

Part Marking

The top marking of the antenna is arranged according to the following illustration.

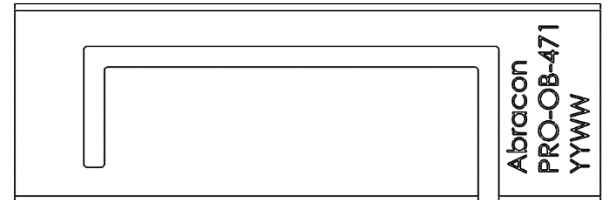
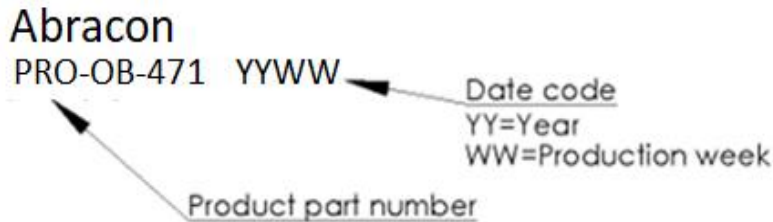

There will be a transition period for the part marking until production batches after 2222 (YYWW). Produced batches before 2222 are marked according to the below illustration.

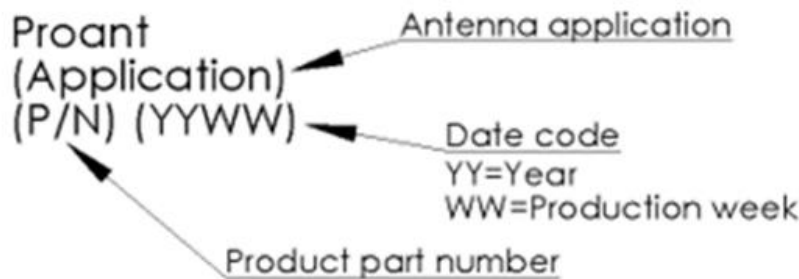

Example top marking

Ordering Information

Part number	Part name	Details
PRO-OB-471	OnBoard SMD 868/915 or 868+2400 MHz	Antenna for 860-870 MHz, 902-928 MHz or 868+2400 MHz operation
PRO-EB-472	Evaluation board, Onboard "SMD 868"	Evaluation board with PRO-OB-471, operation in 860-870 MHz
PRO-EB-476	Evaluation board, Onboard "SMD 915"	Evaluation board with PRO-OB-471, operation in 902-928 MHz
PRO-EB-531	Evaluation board, Onboard "SMD 868+2400"	Evaluation board with PRO-OB-471, operation in 860 - 870 MHz and 2.4 - 2.5 GHz

ATTENTION: Abracon LLC's products are COTS – Commercial-Off-The-Shelf products; suitable for Commercial, Industrial and, where designated, Automotive Applications. Abracon's products are not specifically designed for Military, Aviation, Aerospace, Life-dependent Medical applications or any application requiring high reliability where component failure could result in loss of life and/or property. For applications requiring high reliability and/or presenting an extreme operating environment, written consent and authorization from Abracon LLC is required. Please contact Abracon LLC for more information.



5101 Hidden Creek Ln Spicewood TX 78669
 Phone: 512-371-6159 | Fax: 512-351-8858
 For terms and conditions of sales, please visit:
www.abracon.com

REVISED:

ABRACON IS
 ISO9001-2015
 CERTIFIED

Looking for pricing, stock, or lifecycle information?

Click below to explore more details on WIN SOURCE:

 [View PRO-OB-471 on WIN SOURCE](#)

 [Abracon LLC Information](#)

Optimize Your Supply Chain with WIN SOURCE Solutions

-  Global Sourcing Solution
-  Obsolete Management
-  Cost Control Management
-  Shortage Management
-  Alternative Solution
-  Excess Inventory Management