



**THE DATASHEET OF  
PCA9500D,118**





# PCA9500

8-bit I<sup>2</sup>C-bus and SMBus I/O port with 2-kbit EEPROM

Rev. 4.1 — 5 May 2017

Product data sheet

## 1. General description

---

The PCA9500 is an 8-bit I/O expander with an on-board 2-kbit EEPROM.

The I/O expander's eight quasi-bidirectional data pins can be independently assigned as inputs or outputs to monitor board level status or activate indicator devices such as LEDs. The system master writes to the I/O configuration bits in the same way as for the PCF8574. The data for each input or output is kept in the corresponding Input or Output register. The system master can read all registers.

The EEPROM can be used to store error codes or board manufacturing data for read-back by application software for diagnostic purposes and is included in the I/O expander package.

The PCA9500 has three address pins with internal pull-up resistors allowing up to eight devices to share the common two-wire I<sup>2</sup>C software protocol serial data bus. The fixed GPIO I<sup>2</sup>C-bus address is the same as the PCF8574 and the fixed EEPROM I<sup>2</sup>C-bus address is the same as the PCF8582C-2, so the PCA9500 appears as two separate devices to the bus master.

The PCA9500 supports hot insertion to facilitate usage in removable cards on backplane systems.

The PCA9501 is an alternative to the functionally similar PCA9500 for systems where a higher number of devices are required to share the same I<sup>2</sup>C-bus or an interrupt output is required.

## 2. Features and benefits

---

- Eight general purpose input/output expander/collector
- Drop-in replacement for PCF8574 with integrated 2-kbit EEPROM
- Internal 256 × 8 EEPROM
- Self timed write cycle
- 4 byte page write operation
- I<sup>2</sup>C-bus and SMBus interface logic
- Internal power-on reset
- Noise filter on SCL/SDA inputs
- Three address pins allowing up to eight devices on the I<sup>2</sup>C-bus/SMBus
- No glitch on power-up
- Supports hot insertion
- Power-up with all channels configured as inputs
- Low standby current



- Operating power supply voltage range of 2.5 V to 3.6 V
- 5 V tolerant inputs/outputs
- 0 Hz to 400 kHz clock frequency
- ESD protection exceeds 2000 V HBM per JESD22-A114, 200 V MM per JESD22-A115 and 1000 V CDM per JESD22-C101
- Latch-up testing is done to JEDEC Standard JESD78 which exceeds 100 mA
- Packages offered: SO16, TSSOP16, HVQFN16

### 3. Applications

---

- Board version tracking and configuration
- Board health monitoring and status reporting
- Multi-card systems in telecommunications, networking, and base station infrastructure equipment
- Field recall and troubleshooting functions for installed boards
- General-purpose integrated I/O with memory
- Drop-in replacement for PCF8574 with integrated 2-kbit EEPROM
- Bus master sees GPIO and EEPROM as two separate devices
- Three hardware address pins allow up to eight PCA9500s to be located in the same I<sup>2</sup>C-bus/SMBus

## 4. Ordering information

Table 1. Ordering information

| Type number | Topside marking | Package |  |          |
|-------------|-----------------|---------|--|----------|
|             |                 | Name    | Description  | Version  |
| PCA9500BS   | 9500            | HVQFN16 | plastic thermal enhanced very thin quad flat package; no leads; 16 terminals; body 4 × 4 × 0.85 mm | SOT629-1 |
| PCA9500D    | PCA9500D        | SO16    | plastic small outline package; 16 leads; body width 7.5 mm   | SOT162-1 |
| PCA9500PW   | PCA9500         | TSSOP16 | plastic thin shrink small outline package; 16 leads; body width 4.4 mm                             | SOT403-1 |

### 4.1 Ordering options

Table 2. Ordering options

| Type number | Orderable part number | Package | Packing method  | Minimum order quantity | Temperature                         |
|-------------|-----------------------|---------|---|------------------------|-------------------------------------|
| PCA9500BS   | PCA9500BS,118         | HVQFN16 | REEL 13" Q1/T1<br>*STANDARD MARK<br>SMD               | 6000                   | T <sub>amb</sub> = -40 °C to +85 °C |
|             | PCA9500BSHP           | HVQFN16 | REEL 13" Q2/T3<br>*STANDARD MARK<br>SMD               | 6000                   | T <sub>amb</sub> = -40 °C to +85 °C |
| PCA9500D    | PCA9500D,112          | SO16    | STANDARD<br>MARKING * IC'S<br>TUBE - DSC BULK<br>PACK | 1920                   | T <sub>amb</sub> = -40 °C to +85 °C |
|             | PCA9500D,118          | SO16    | REEL 13" Q1/T1<br>*STANDARD MARK<br>SMD               | 1000                   | T <sub>amb</sub> = -40 °C to +85 °C |
| PCA9500PW   | PCA9500PW,112         | TSSOP16 | STANDARD<br>MARKING * IC'S<br>TUBE - DSC BULK<br>PACK | 2400                   | T <sub>amb</sub> = -40 °C to +85 °C |
|             | PCA9500PW,118         | TSSOP16 | REEL 13" Q1/T1<br>*STANDARD MARK<br>SMD               | 2500                   | T <sub>amb</sub> = -40 °C to +85 °C |

### 5. Block diagram

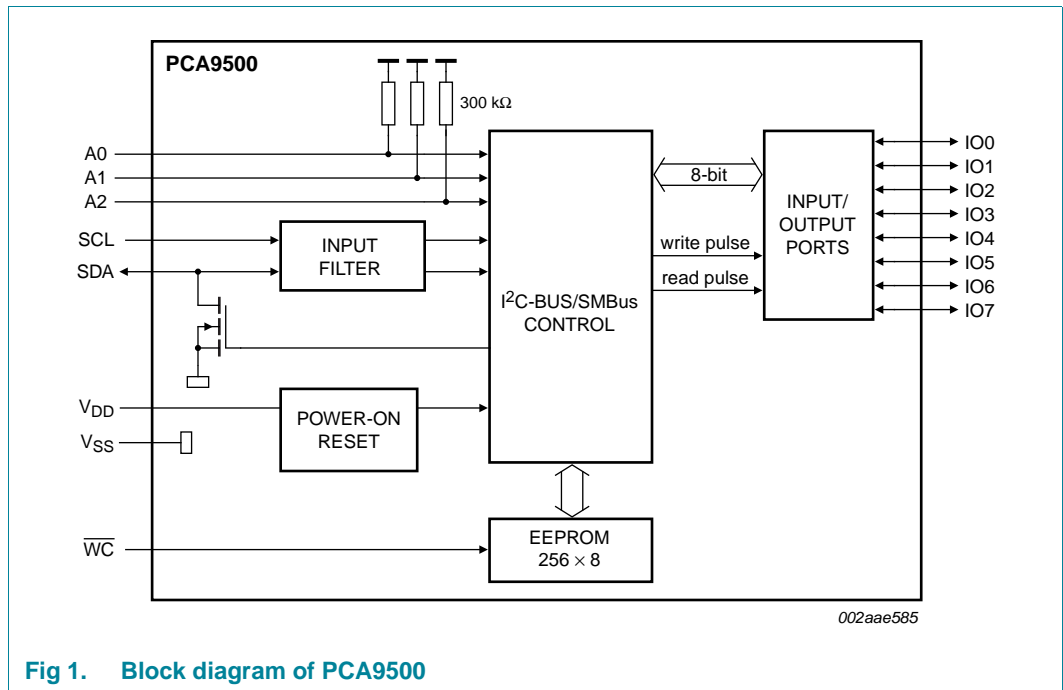

Fig 1. Block diagram of PCA9500

## 6. Pinning information

### 6.1 Pinning

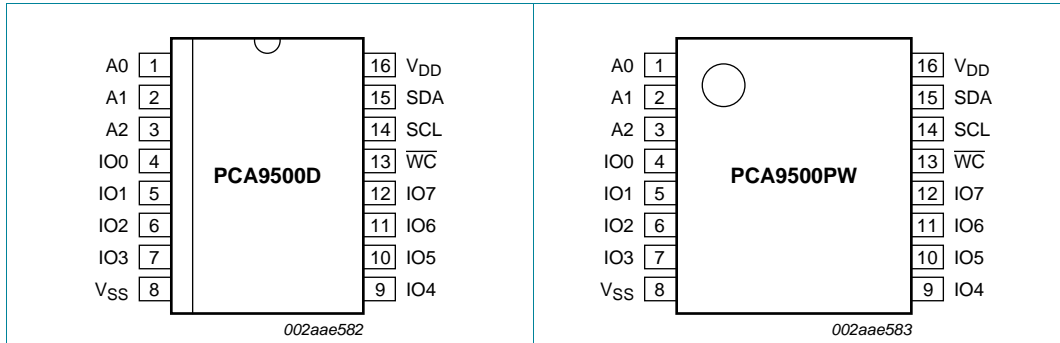

Fig 2. Pin configuration for SO16

Fig 3. Pin configuration for TSSOP16

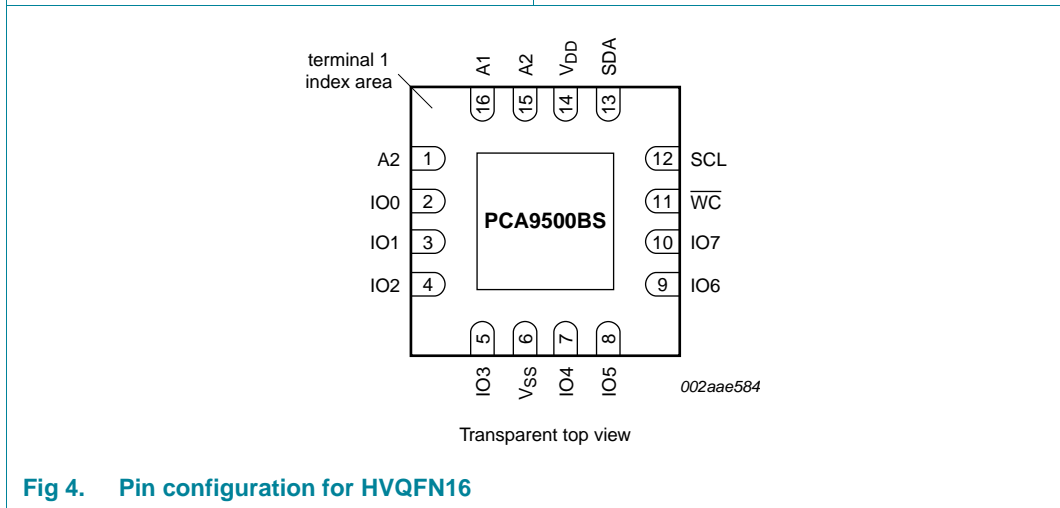

Fig 4. Pin configuration for HVQFN16

### 6.2 Pin description

Table 3. Pin description

| Symbol | Pin           |         | Description                      |
|--------|---------------|---------|----------------------------------|
|        | SO16, TSSOP16 | HVQFN16 |                                  |
| A0     | 1             | 15      | address lines (internal pull-up) |
| A1     | 2             | 16      |                                  |
| A2     | 3             | 1       |                                  |
| IO0    | 4             | 2       | quasi-bidirectional I/O pins     |
| IO1    | 5             | 3       |                                  |
| IO2    | 6             | 4       |                                  |
| IO3    | 7             | 5       |                                  |
| IO4    | 9             | 7       |                                  |
| IO5    | 10            | 8       |                                  |
| IO6    | 11            | 9       |                                  |
| IO7    | 12            | 10      |                                  |

Table 3. Pin description ...continued

| Symbol          | Pin           |                  | Description                       |
|-----------------|---------------|------------------|-----------------------------------|
|                 | SO16, TSSOP16 | HVQFN16          |                                   |
| V <sub>SS</sub> | 8             | 6 <sup>[1]</sup> | supply ground                     |
| $\overline{WC}$ | 13            | 11               | active LOW write control pin      |
| SCL             | 14            | 12               | I <sup>2</sup> C-bus serial clock |
| SDA             | 15            | 13               | I <sup>2</sup> C-bus serial data  |
| V <sub>DD</sub> | 16            | 14               | supply voltage                    |

- [1] HVQFN16 package supply ground is connected to both V<sub>SS</sub> pin and exposed center pad. V<sub>SS</sub> pin must be connected to supply ground for proper device operation. For enhanced thermal, electrical, and board level performance, the exposed pad needs to be soldered to the board using a corresponding thermal pad on the board and for proper heat conduction through the board, thermal vias need to be incorporated in the printed-circuit board in the thermal pad region.

## 7. Functional description

Refer also to [Figure 1 “Block diagram of PCA9500”](#).

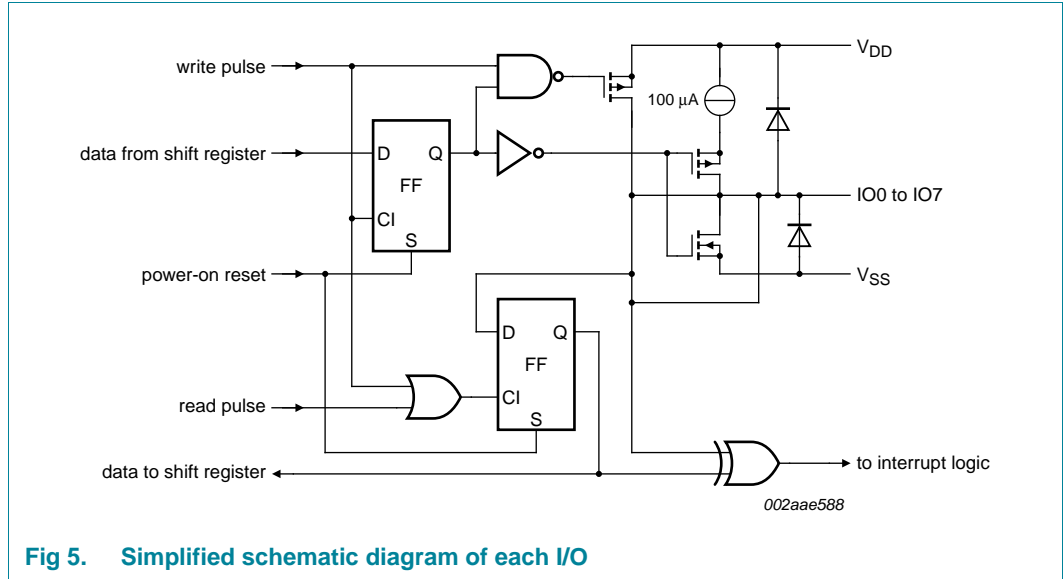
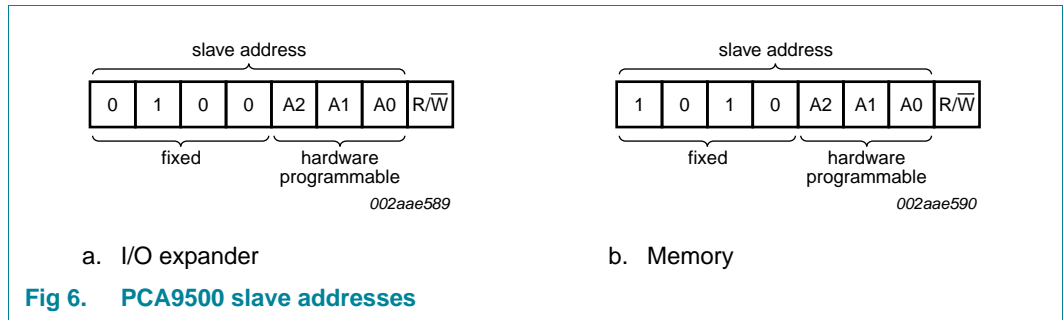

**Fig 5. Simplified schematic diagram of each I/O**

### 7.1 Device addressing

Following a START condition, the bus master must output the address of the slave it is accessing. The address of the PCA9500 is shown in [Figure 6](#). Internal pull-up resistors are incorporated on the hardware selectable address pins.

The last bit of the address byte defines the operation to be performed. When set to logic 1 a read is selected, while a logic 0 selects a write operation.



**Fig 6. PCA9500 slave addresses**

### 7.2 Control register

The PCA9500 contains a single 8-bit register called the Control register, which can be written and read via the I<sup>2</sup>C-bus. This register is sent after a successful acknowledgment of the slave address. It contains the I/O operation information.

### 7.3 I/O operations

(Refer also to [Figure 5](#).)

Each of the PCA9500's eight I/Os can be independently used as an input or output. Output data is transmitted to the port by the I/O Write mode (see [Figure 7](#)). Input I/O data is transferred from the port to the microcontroller by the Read mode (see [Figure 8](#)).

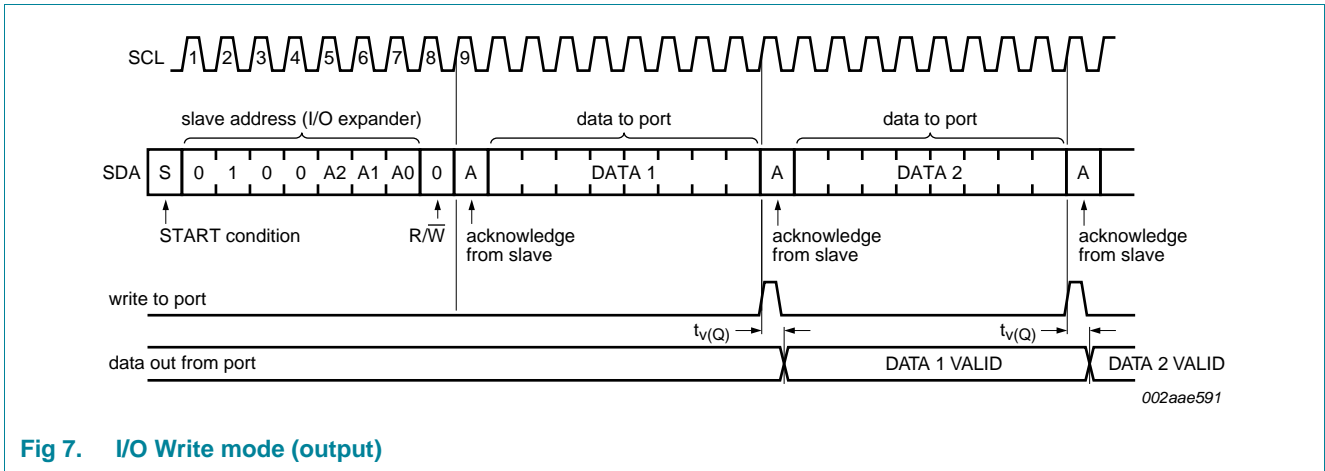

Fig 7. I/O Write mode (output)

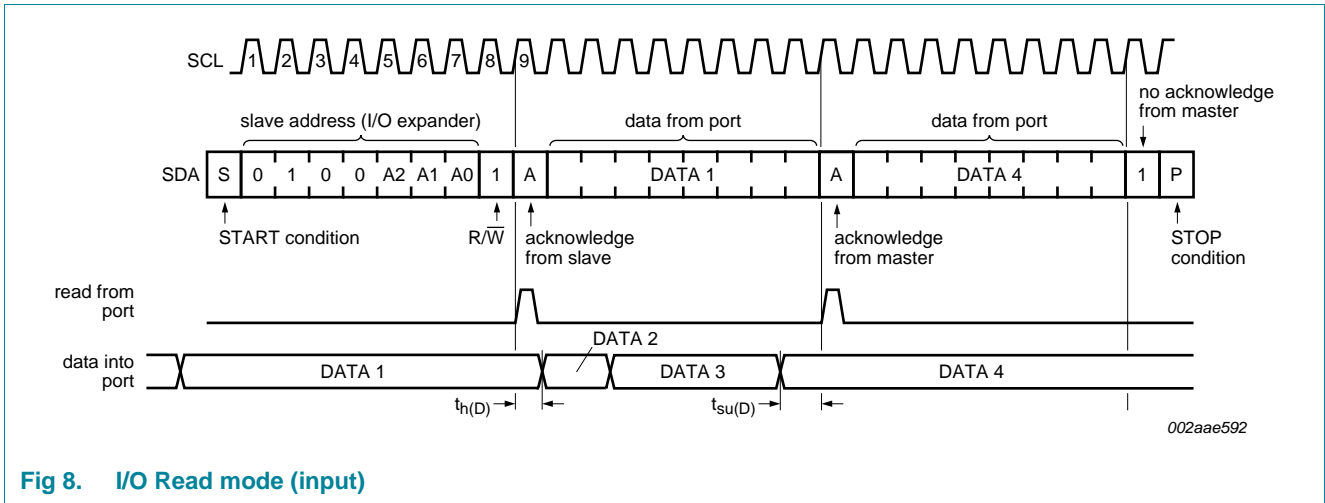

Fig 8. I/O Read mode (input)

### 7.3.1 Quasi-bidirectional I/Os

A quasi-bidirectional I/O can be used as an input or output without the use of a control signal for data direction. At power-on the I/Os are HIGH. In this mode, only a current source to V<sub>DD</sub> is active. An additional strong pull-up to V<sub>DD</sub> allows fast rising edges into heavily loaded outputs. These devices turn on when an output is written HIGH, and are switched off by the negative edge of SCL. The I/Os should be HIGH before being used as inputs. See [Figure 9](#).

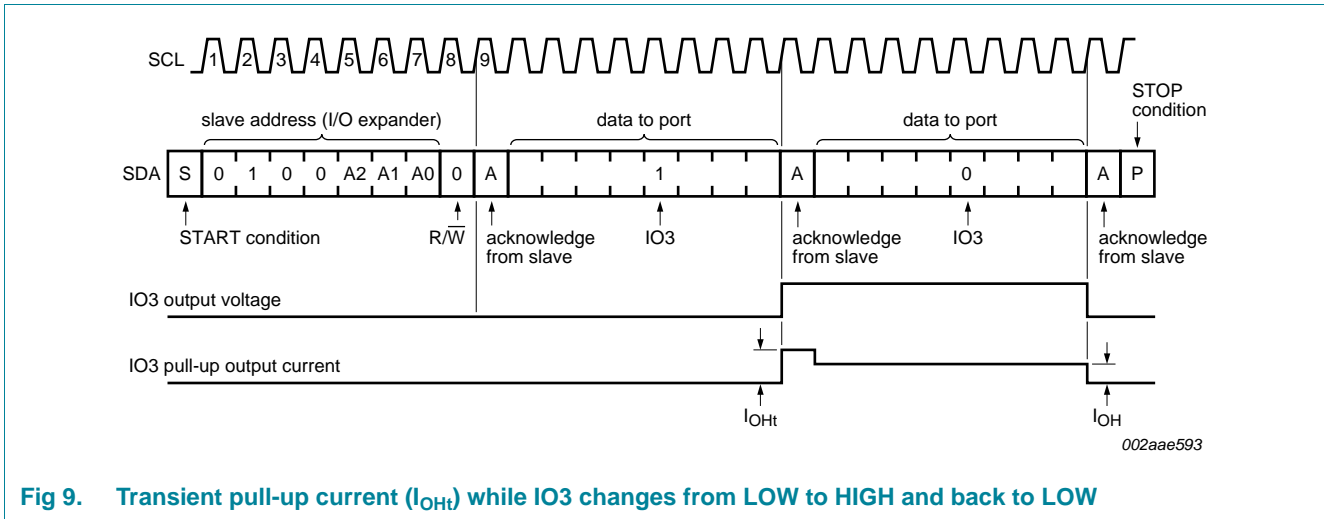

Fig 9. Transient pull-up current ( $I_{OHt}$ ) while IO3 changes from LOW to HIGH and back to LOW

## 7.4 Memory operations

### 7.4.1 Write operations

Write operations require an additional address field to indicate the memory address location to be written. The address field is eight bits long, providing access to any one of the 256 words of memory. There are two types of write operations, 'byte write' and 'page write'.

Write operation is possible when the Write Control pin ( $\overline{WC}$ ) is put at a LOW logic level (0). When this control signal is set at 1, write operation is not possible and data in the memory is protected.

'Byte write' and 'page write' explained below assume that  $\overline{WC}$  is set to 0.

#### 7.4.1.1 Byte write

To perform a byte write the START condition is followed by the memory slave address and the R/W bit set to 0. The PCA9500 will respond with an acknowledge and then consider the next eight bits sent as the word address and the eight bits after the word address as the data. The PCA9500 will issue an acknowledge after the receipt of both the word address and the data. To terminate the data transfer the master issues the STOP condition, initiating the internal write cycle to the non-volatile memory. Only write and read operations to the quasi-bidirectional I/Os are allowed during the internal write cycle.

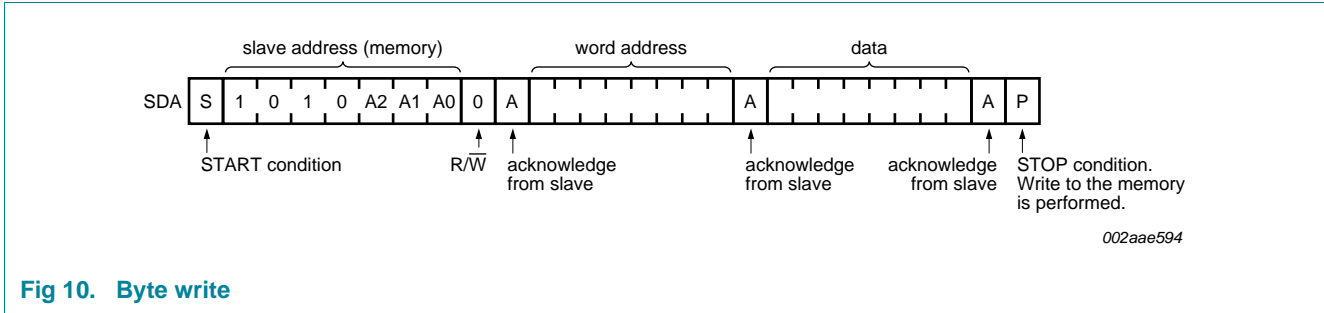

Fig 10. Byte write

7.4.1.2 Page write

A page write is initiated in the same way as the byte write. If after sending the first word of data, the STOP condition is not received, the PCA9500 considers subsequent words as data. After each data word the PCA9500 responds with an acknowledge and the two least significant bits of the memory address field are incremented. Should the master not send a STOP condition after four data words, the address counter will return to its initial value and overwrite the data previously written. After the receipt of the STOP condition the inputs will behave as with the byte write during the internal write cycle.

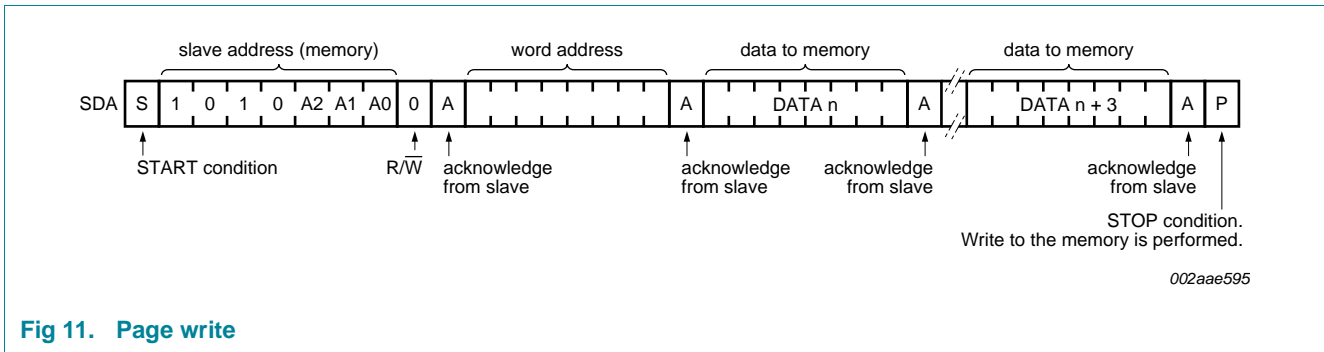

Fig 11. Page write

7.4.2 Read operations

PCA9500 read operations are initiated in an identical manner to write operations with the exception that the memory slave address R/W bit is set to '1'. There are three types of read operations: current address read, random read and sequential read.

7.4.2.1 Current address read

The PCA9500 contains an internal address counter that increments after each read or write access and as a result, if the last word accessed was at address 'n', then the address counter contains the address 'n + 1'.

When the PCA9500 receives its memory slave address with the R/W bit set to one it issues an acknowledge and uses the next eight clocks to transmit the data contained at the address stored in the address counter. The master ceases the transmission by issuing the STOP condition after the eighth bit. There is no ninth clock cycle for the acknowledge. See [Figure 12](#).

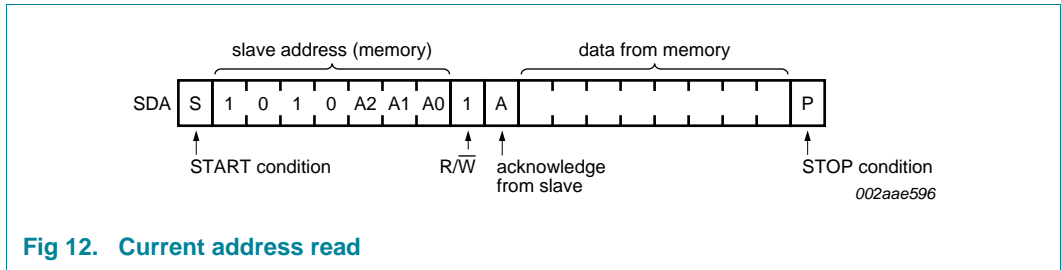

Fig 12. Current address read

7.4.2.2 Random read

The PCA9500's random read mode allows the address to be read from to be specified by the master. This is done by performing a dummy write to set the address counter to the location to be read. The master must perform a byte write to the address location to be read, but instead of transmitting the data after receiving the acknowledge from the PCA9500, the master re-issues the START condition and memory slave address with the R/W bit set to one. The PCA9500 will then transmit an acknowledge and use the next eight clock cycles to transmit the data contained in the addressed location. The master ceases the transmission by issuing the STOP condition after the eighth bit, omitting the ninth clock cycle acknowledge.

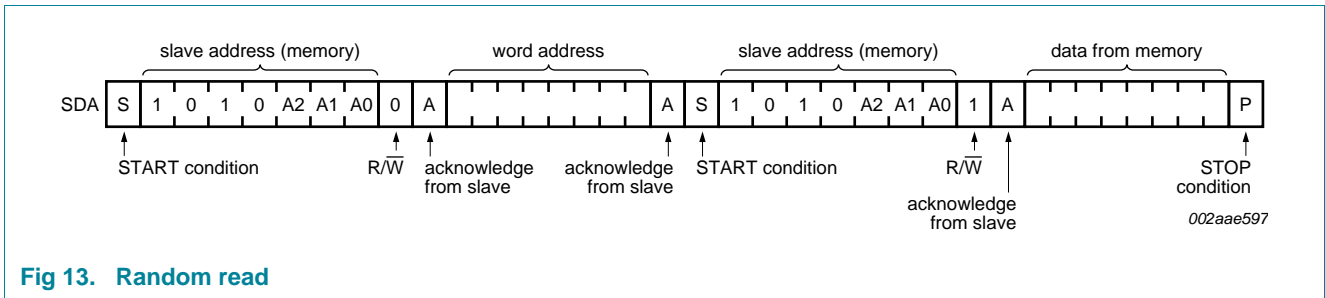

Fig 13. Random read

7.4.2.3 Sequential read

The PCA9500 sequential read is an extension of either the current address read or random read. If the master does not issue a STOP condition after it has received the eighth data bit, but instead issues an acknowledge, the PCA9500 will increment the address counter and use the next eight cycles to transmit the data from that location. The master can continue this process to read the contents of the entire memory. Upon reaching address 255 the counter will return to address 0 and continue transmitting data until a STOP condition is received. The master ceases the transmission by issuing the STOP condition after the eighth bit, omitting the ninth clock cycle acknowledge.

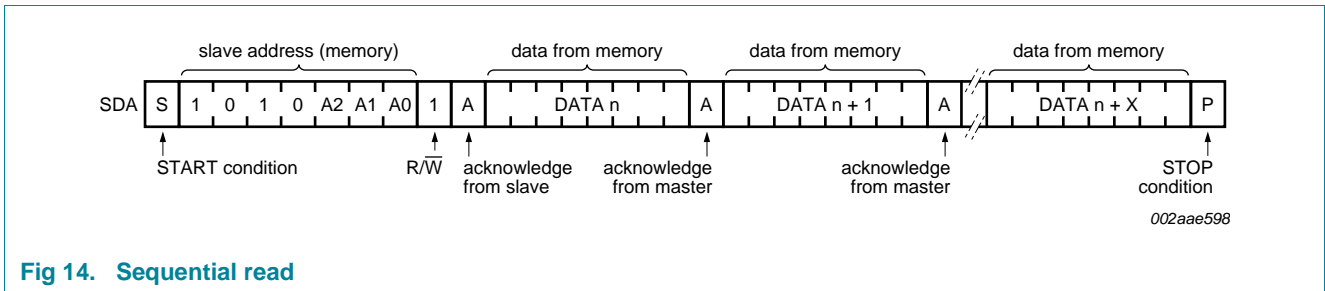

Fig 14. Sequential read

## 8. Characteristics of the I<sup>2</sup>C-bus

The I<sup>2</sup>C-bus is for 2-way, 2-line communication between different ICs or modules. The two lines are a serial data line (SDA) and a serial clock line (SCL). Both lines must be connected to a positive supply via a pull-up resistor when connected to the output stages of a device. Data transfer may be initiated only when the bus is not busy.

### 8.1 Bit transfer

One data bit is transferred during each clock pulse. The data on the SDA line must remain stable during the HIGH period of the clock pulse as changes in the data line at this time will be interpreted as control signals (see [Figure 15](#)).

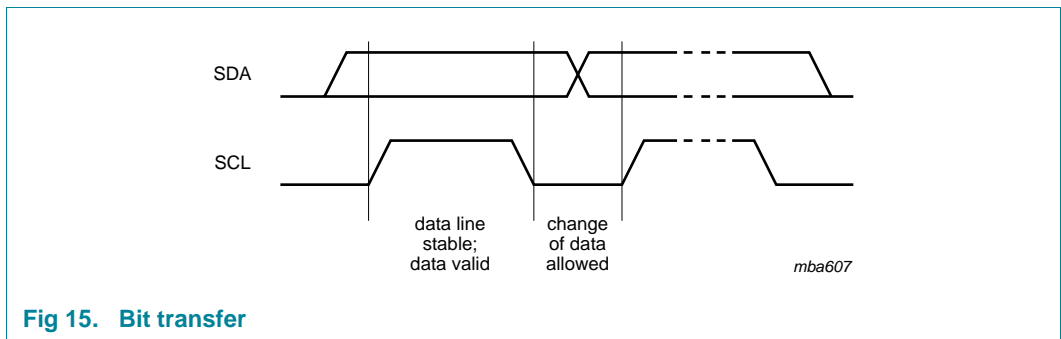

Fig 15. Bit transfer

#### 8.1.1 START and STOP conditions

Both data and clock lines remain HIGH when the bus is not busy. A HIGH-to-LOW transition of the data line while the clock is HIGH is defined as the START condition (S). A LOW-to-HIGH transition of the data line while the clock is HIGH is defined as the STOP condition (P) (see [Figure 16](#)).

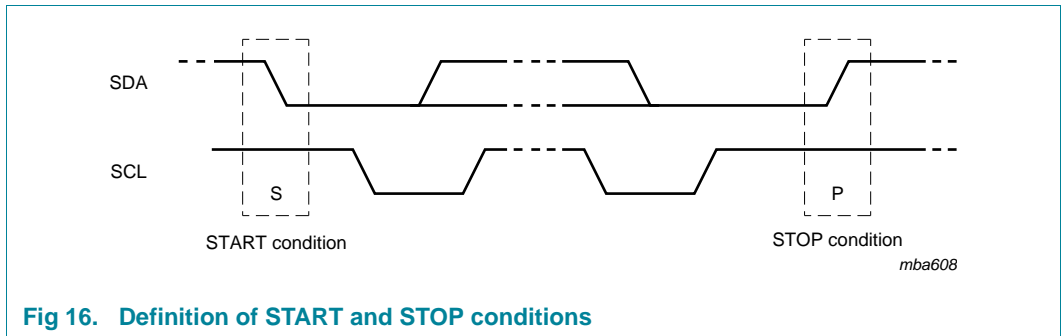

Fig 16. Definition of START and STOP conditions

### 8.2 System configuration

A device generating a message is a 'transmitter'; a device receiving is the 'receiver'. The device that controls the message is the 'master' and the devices which are controlled by the master are the 'slaves' (see [Figure 17](#)).

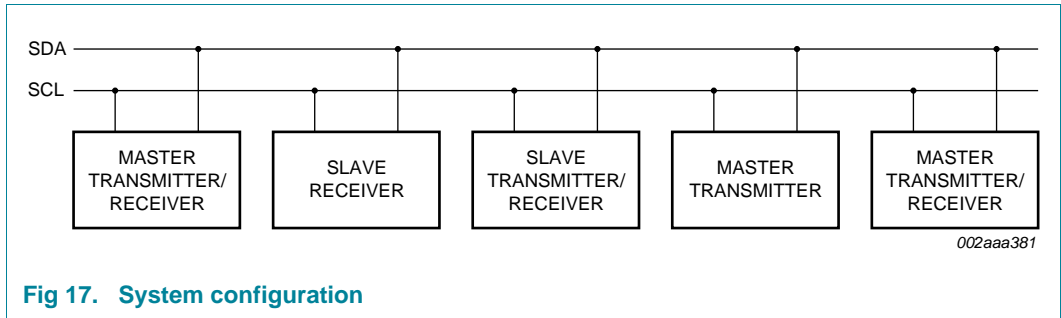

Fig 17. System configuration

### 8.3 Acknowledge

The number of data bytes transferred between the START and the STOP conditions from transmitter to receiver is not limited. Each byte of eight bits is followed by one acknowledge bit. The acknowledge bit is a HIGH level put on the bus by the transmitter, whereas the master generates an extra acknowledge related clock pulse.

A slave receiver which is addressed must generate an acknowledge after the reception of each byte. Also a master must generate an acknowledge after the reception of each byte that has been clocked out of the slave transmitter. The device that acknowledges has to pull down the SDA line during the acknowledge clock pulse, so that the SDA line is stable LOW during the HIGH period of the acknowledge related clock pulse; set-up time and hold time must be taken into account.

A master receiver must signal an end of data to the transmitter by not generating an acknowledge on the last byte that has been clocked out of the slave. In this event, the transmitter must leave the data line HIGH to enable the master to generate a STOP condition.

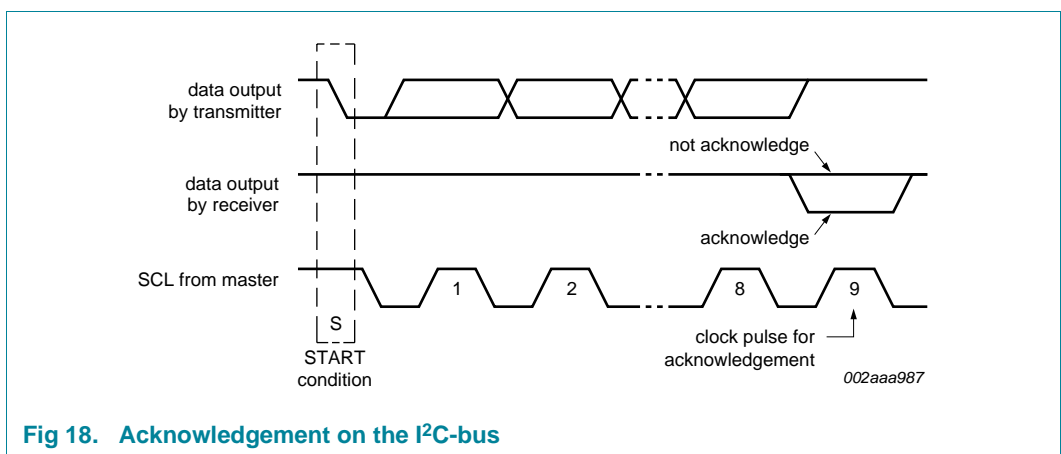

Fig 18. Acknowledgement on the I<sup>2</sup>C-bus

### 9. Application design-in information

A central processor/controller typically located on the system main board can use the 400 kHz I<sup>2</sup>C-bus/SMBus to poll the PCA9500 devices located on the system cards for status or version control type of information. The PCA9500 may be programmed at manufacturing to store information regarding board build, firmware version, manufacturer identification, configuration option data, and so on. Alternately, these devices can be used as convenient interface for board configuration, thereby utilizing the I<sup>2</sup>C-bus/SMBus as an intra-system communication bus.

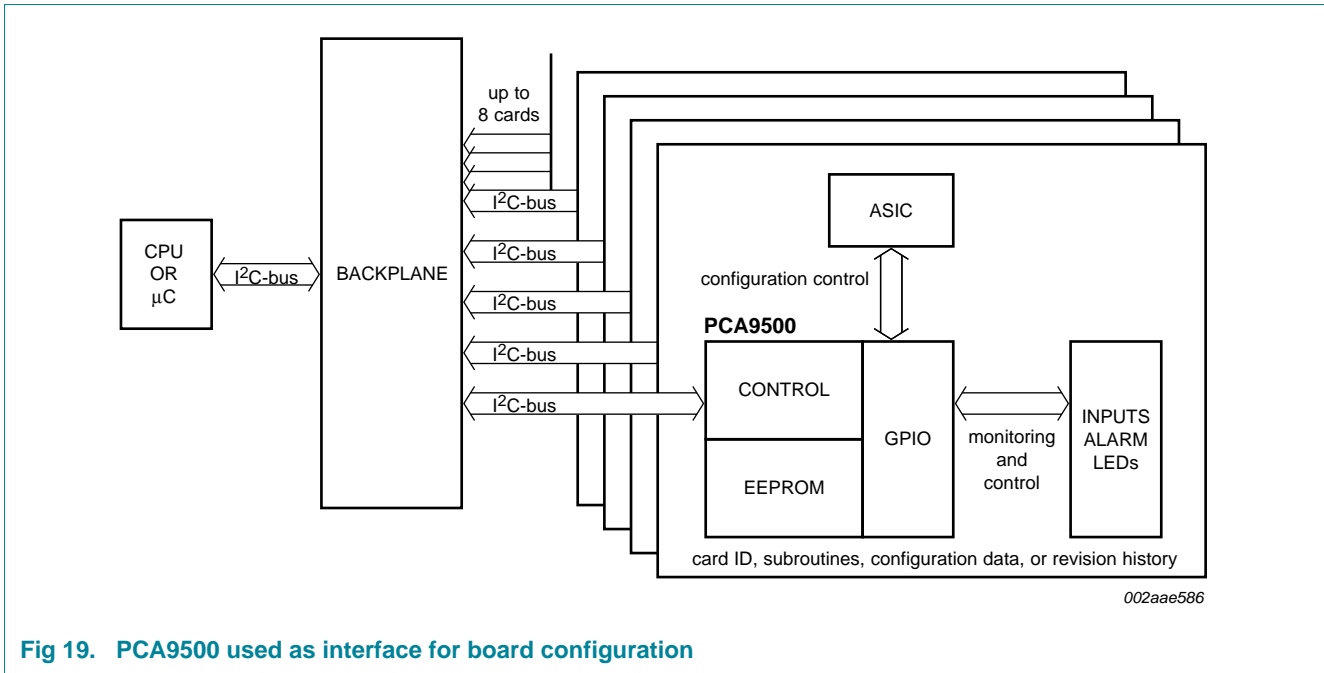

Fig 19. PCA9500 used as interface for board configuration

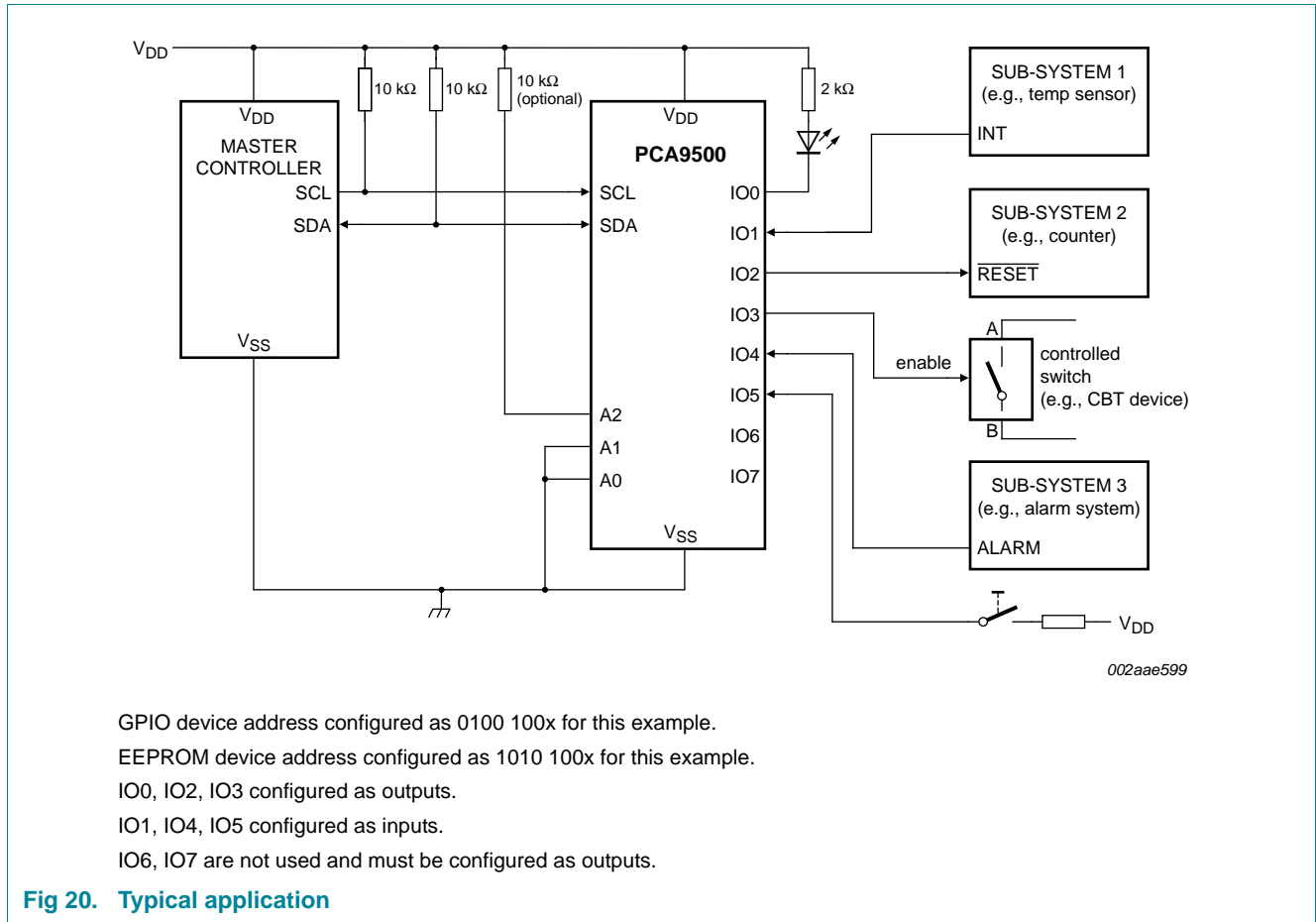

Fig 20. Typical application

## 10. Limiting values

Table 4. Limiting values

In accordance with the Absolute Maximum Rating System (IEC 60134).

| Symbol           | Parameter                    | Conditions | Min                   | Max  | Unit |
|------------------|------------------------------|------------|-----------------------|------|------|
| V <sub>DD</sub>  | supply voltage               |            | -0.5                  | +4.0 | V    |
| V <sub>I</sub>   | input voltage                |            | V <sub>SS</sub> - 0.5 | 5.5  | V    |
| I <sub>I</sub>   | input current                |            | -20                   | +20  | mA   |
| I <sub>O</sub>   | output current               |            | -25                   | +25  | mA   |
| I <sub>DD</sub>  | supply current               |            | -100                  | +100 | mA   |
| I <sub>SS</sub>  | ground supply current        |            | -100                  | +100 | mA   |
| P <sub>tot</sub> | total power dissipation      |            | -                     | 400  | mW   |
| P/out            | power dissipation per output |            | -                     | 100  | mW   |
| T <sub>stg</sub> | storage temperature          |            | -65                   | +150 | °C   |
| T <sub>amb</sub> | ambient temperature          | operating  | -40                   | +85  | °C   |

## 11. Static characteristics

Table 5. Static characteristics

| Symbol                                     | Parameter                               | Conditions  | Min                | Typ | Max                 | Unit |
|--|---|---|--------------------|-----|---------------------|------|
| <b>Supply</b>                              |   |   |                    |     |                     |      |
| V <sub>DD</sub>                            | supply voltage                          |   | 2.5                | 3.3 | 3.6                 | V    |
| I <sub>DDQ</sub>                           | standby current                         | A0, A1, A2, $\overline{WC}$ = HIGH                  | -                  | -   | 60                  | μA   |
| I <sub>DD1</sub>                           | supply current read                     |   | -                  | -   | 1                   | mA   |
| I <sub>DD2</sub>                           | supply current write                    |   | -                  | -   | 2                   | mA   |
| V <sub>POR</sub>                           | power-on reset voltage                  |   | -                  | -   | 2.4                 | V    |
| <b>Input SCL; input/output SDA</b>         |   |   |                    |     |                     |      |
| V <sub>IL</sub>                            | LOW-level input voltage                 |   | -0.5               | -   | +0.3V <sub>DD</sub> | V    |
| V <sub>IH</sub>                            | HIGH-level input voltage                |   | 0.7V <sub>DD</sub> | -   | 5.5                 | V    |
| I <sub>OL</sub>                            | LOW-level output current                | V <sub>OL</sub> = 0.4 V                             | 3                  | -   | -                   | mA   |
| I <sub>LI</sub>                            | input leakage current                   | V <sub>I</sub> = V <sub>DD</sub> or V <sub>SS</sub> | -1                 | -   | +1                  | μA   |
| C <sub>i</sub>                             | input capacitance                       | V <sub>I</sub> = V <sub>SS</sub>                    | -                  | -   | 7                   | pF   |
| <b>I/O expander port</b>                   |   |   |                    |     |                     |      |
| V <sub>IL</sub>                            | LOW-level input voltage                 |   | -0.5               | -   | +0.3V <sub>DD</sub> | V    |
| V <sub>IH</sub>                            | HIGH-level input voltage                |   | 0.7V <sub>DD</sub> | -   | 5.5                 | V    |
| I <sub>IHL(max)</sub>                      | input current through protection diodes |   | -400               | -   | +400                | μA   |
| I <sub>OL</sub>                            | LOW-level output current                | V <sub>OL</sub> = 1 V                               | [1]                | 25  | -                   | mA   |
| I <sub>OH</sub>                            | HIGH-level output current               | V <sub>OH</sub> = V <sub>SS</sub>                   | 30                 | 100 | 300                 | μA   |
| I <sub>OHt</sub>                           | transient pull-up current               |   | -                  | 2   | -                   | mA   |
| C <sub>i</sub>                             | input capacitance                       |   | -                  | -   | 10                  | pF   |
| C <sub>o</sub>                             | output capacitance                      |   | -                  | -   | 10                  | pF   |
| <b>Address inputs A0, A1, A2; WC input</b> |   |   |                    |     |                     |      |
| V <sub>IL</sub>                            | LOW-level input voltage                 |   | -0.5               | -   | +0.3V <sub>DD</sub> | V    |
| V <sub>IH</sub>                            | HIGH-level input voltage                |   | 0.7V <sub>DD</sub> | -   | 5.5                 | V    |
| I <sub>LI</sub>                            | input leakage current                   | V <sub>I</sub> = V <sub>DD</sub>                    | -1                 | -   | +1                  | μA   |
|  |   | pull-up; V <sub>I</sub> = V <sub>SS</sub>           | 10                 | 25  | 100                 | μA   |

[1] Each I/O must be externally limited to a maximum of 25 mA and the device must be limited to a maximum current of 100 mA.

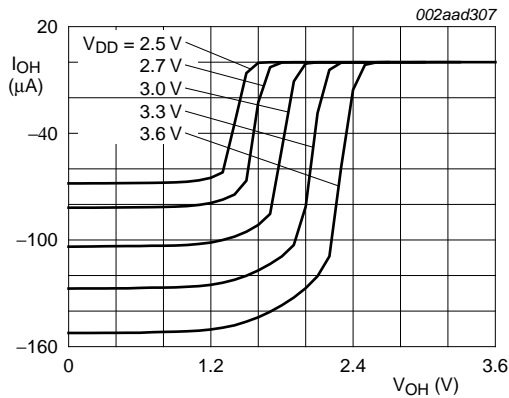

a.  $T_{amb} = -40\text{ }^{\circ}\text{C}$

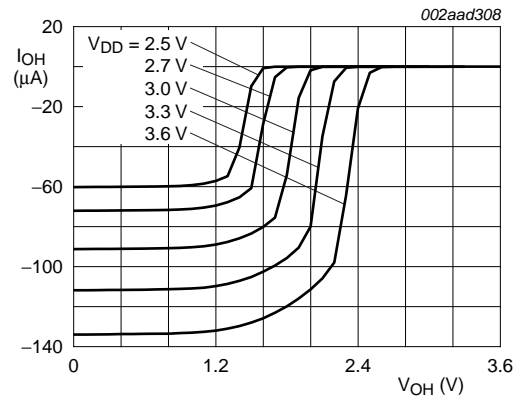

b.  $T_{amb} = 25\text{ }^{\circ}\text{C}$

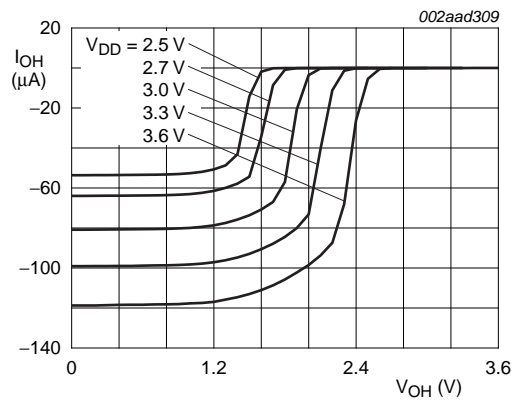

c.  $T_{amb} = 85\text{ }^{\circ}\text{C}$

Fig 21.  $V_{OH}$  versus  $I_{OH}$

**Remark:** Rapid fall-off in  $V_{OH}$  at current inception is due to a diode that provides 5 V overvoltage protection for the GPIO I/O pins. When the GPIO I/O are being used as inputs, the internal current source  $V_{OH}$  should be evaluated to determine if external pull-up resistors are required to provide sufficient  $V_{IH}$  threshold noise margin.

## 12. Dynamic characteristics

Table 6. Dynamic characteristics

| Symbol  | Parameter   | Conditions              | Min | Typ | Max | Unit |
|---|---|-------------------------|-----|-----|-----|------|
| <b>I<sup>2</sup>C-bus timing</b> <sup>[1]</sup> (see Figure 22) |   |                         |     |     |     |      |
| f <sub>SCL</sub>  | SCL clock frequency   |                         | -   | -   | 400 | kHz  |
| t <sub>SP</sub>   | pulse width of spikes that must be suppressed by the input filter |                         | -   | -   | 50  | ns   |
| t <sub>BUF</sub>  | bus free time between a STOP and START condition                  |                         | 1.3 | -   | -   | μs   |
| t <sub>SU;STA</sub>   | set-up time for a repeated START condition                        |                         | 0.6 | -   | -   | μs   |
| t <sub>HD;STA</sub>   | hold time (repeated) START condition                              |                         | 0.6 | -   | -   | μs   |
| t <sub>r</sub>  | rise time of both SDA and SCL signals                             |                         | -   | -   | 0.3 | μs   |
| t <sub>f</sub>  | fall time of both SDA and SCL signals                             |                         | -   | -   | 0.3 | μs   |
| t <sub>SU;DAT</sub>   | data set-up time  |                         | 250 | -   | -   | ns   |
| t <sub>HD;DAT</sub>   | data hold time  |                         | 0   | -   | -   | ns   |
| t <sub>VD;DAT</sub>   | data valid time   | SCL LOW to data output  | -   | -   | 1.0 | μs   |
| t <sub>SU;STO</sub>   | set-up time for STOP condition                                    |                         | 0.6 | -   | -   | μs   |
| <b>Port timing</b>  |   |                         |     |     |     |      |
| t <sub>V(Q)</sub>   | data output valid time  | C <sub>L</sub> ≤ 100 pF | -   | -   | 4   | μs   |
| t <sub>su(D)</sub>  | data input set-up time  | C <sub>L</sub> ≤ 100 pF | 0   | -   | -   | μs   |
| t <sub>h(D)</sub>   | data input hold time  | C <sub>L</sub> ≤ 100 pF | 4   | -   | -   | μs   |
| <b>Power-up timing</b>  |   |                         |     |     |     |      |
| t <sub>pu(R)</sub>  | read power-up time  |                         | [2] | -   | 1   | ms   |
| t <sub>pu(W)</sub>  | write power-up time   |                         | [2] | -   | 5   | ms   |
| <b>Write cycle limits (see Figure 23)</b>                       |   |                         |     |     |     |      |
| T <sub>cy(W)</sub>  | write cycle time  |                         | [3] | 5   | 10  | ms   |

[1] All the timing values are valid within the operating supply voltage and ambient temperature range and refer to V<sub>IL</sub> and V<sub>IH</sub> with an input voltage swing of V<sub>SS</sub> to V<sub>DD</sub>.

[2] t<sub>pu(R)</sub> and t<sub>pu(W)</sub> are the delays required from the time V<sub>DD</sub> is stable until the specified operation can be initiated. These parameters are guaranteed by design.

[3] T<sub>cy(W)</sub> is the maximum time that the device requires to perform the internal write operation.

Table 7. Non-volatile storage specifications

| Parameter                          | Specification          |
|------------------------------------|------------------------|
| memory cell data retention         | 10 years minimum       |
| number of memory cell write cycles | 100,000 cycles minimum |

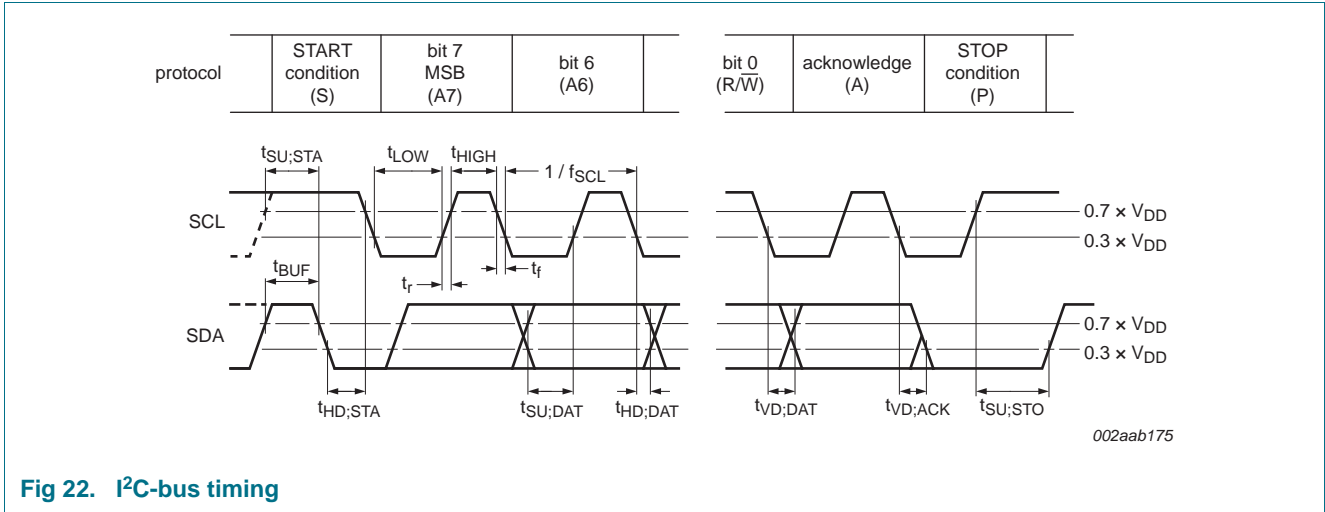

Fig 22. I<sup>2</sup>C-bus timing

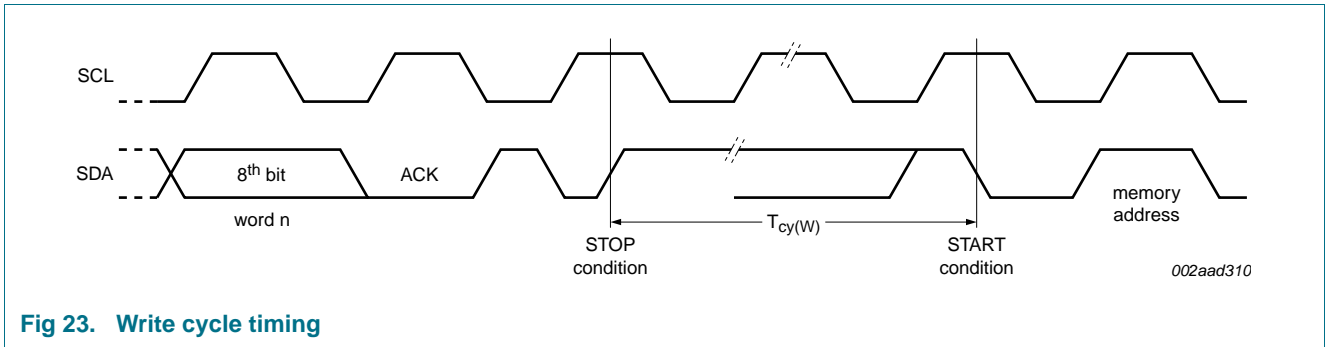

Fig 23. Write cycle timing

13. Package outline

SO16: plastic small outline package; 16 leads; body width 7.5 mm

SOT162-1

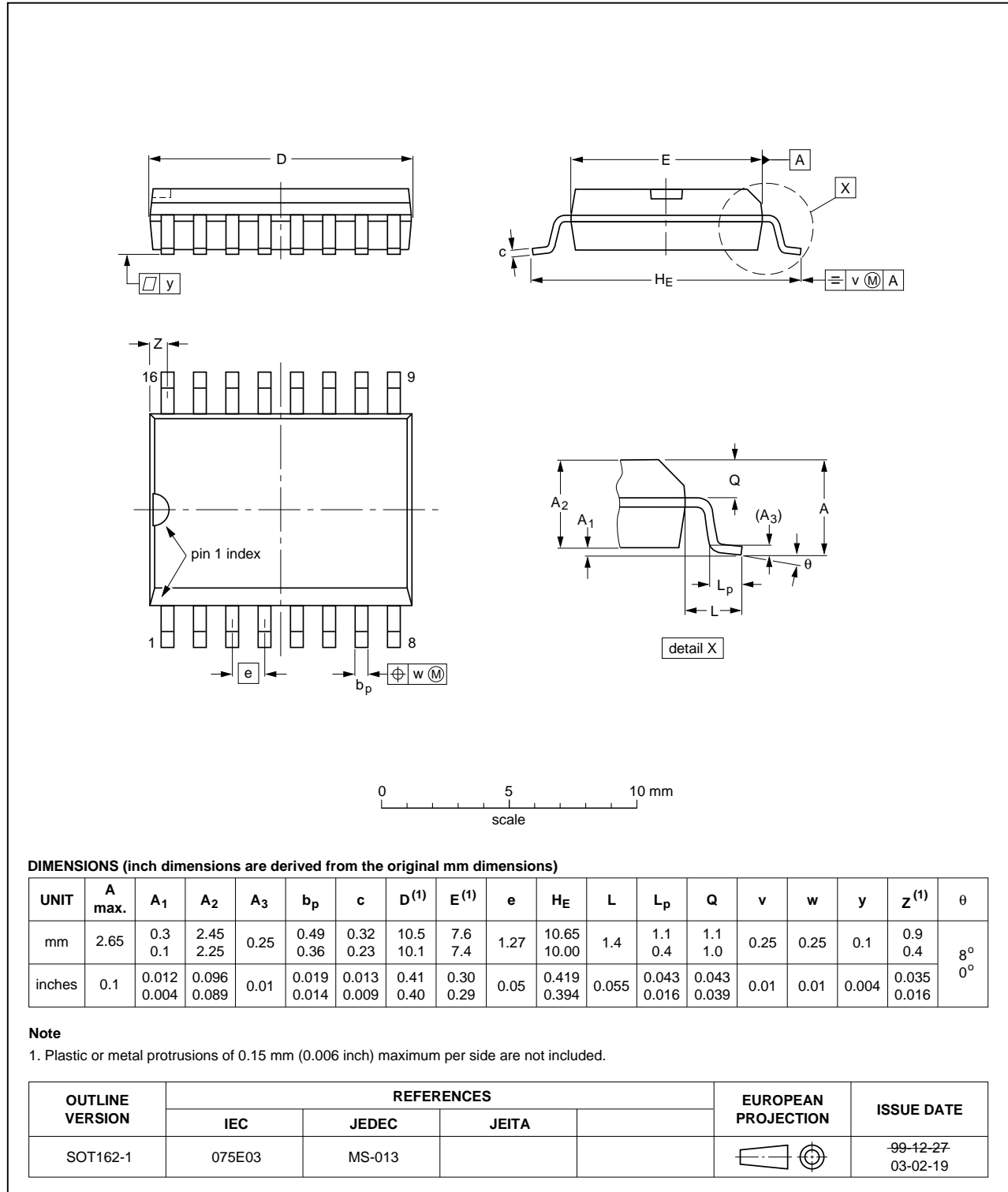

Fig 24. Package outline SOT162-1 (SO16)

TSSOP16: plastic thin shrink small outline package; 16 leads; body width 4.4 mm

SOT403-1

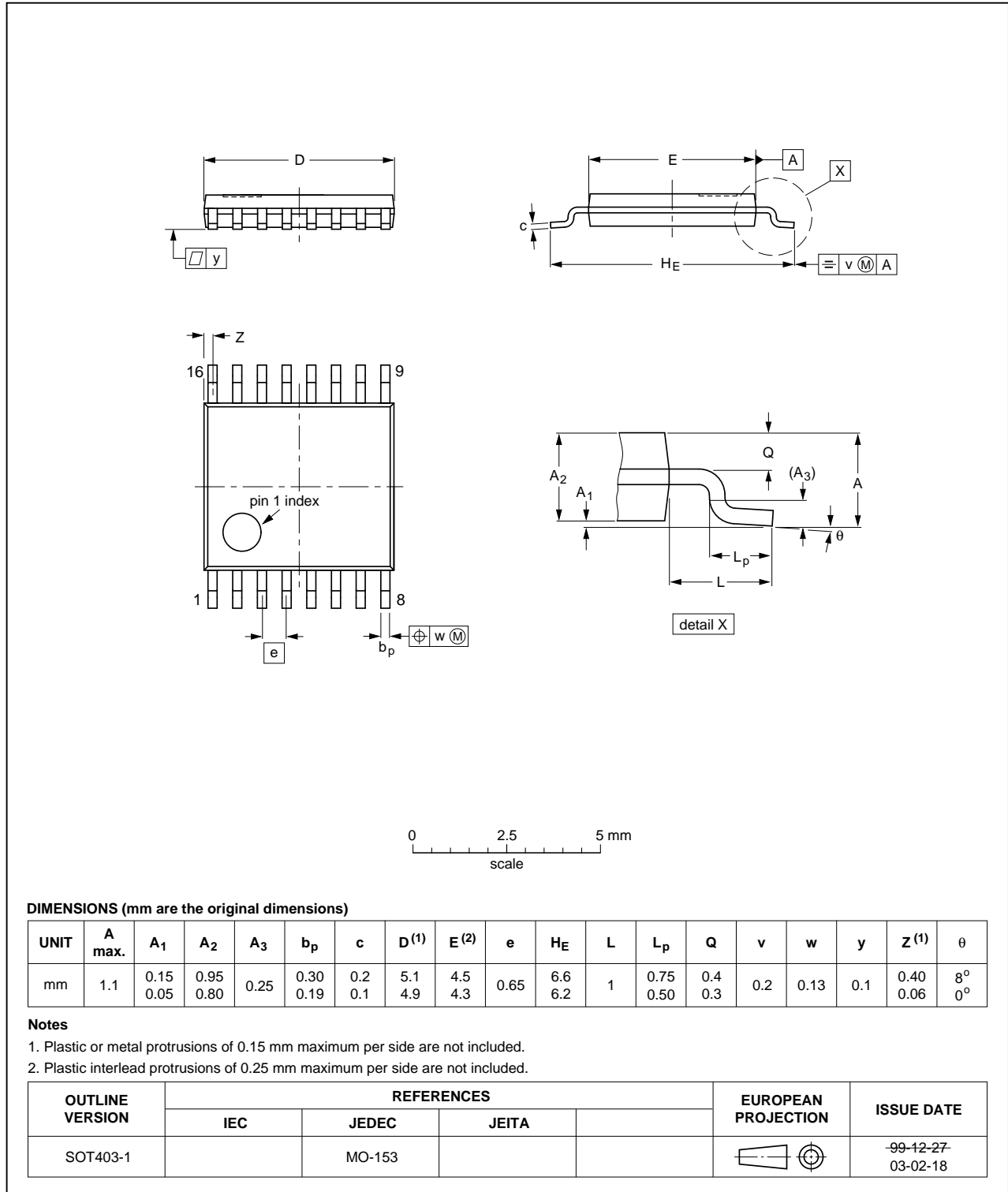

Fig 25. Package outline SOT403-1 (TSSOP16)

**HVQFN16: plastic thermal enhanced very thin quad flat package; no leads;**  
**16 terminals; body 4 x 4 x 0.85 mm**

SOT629-1

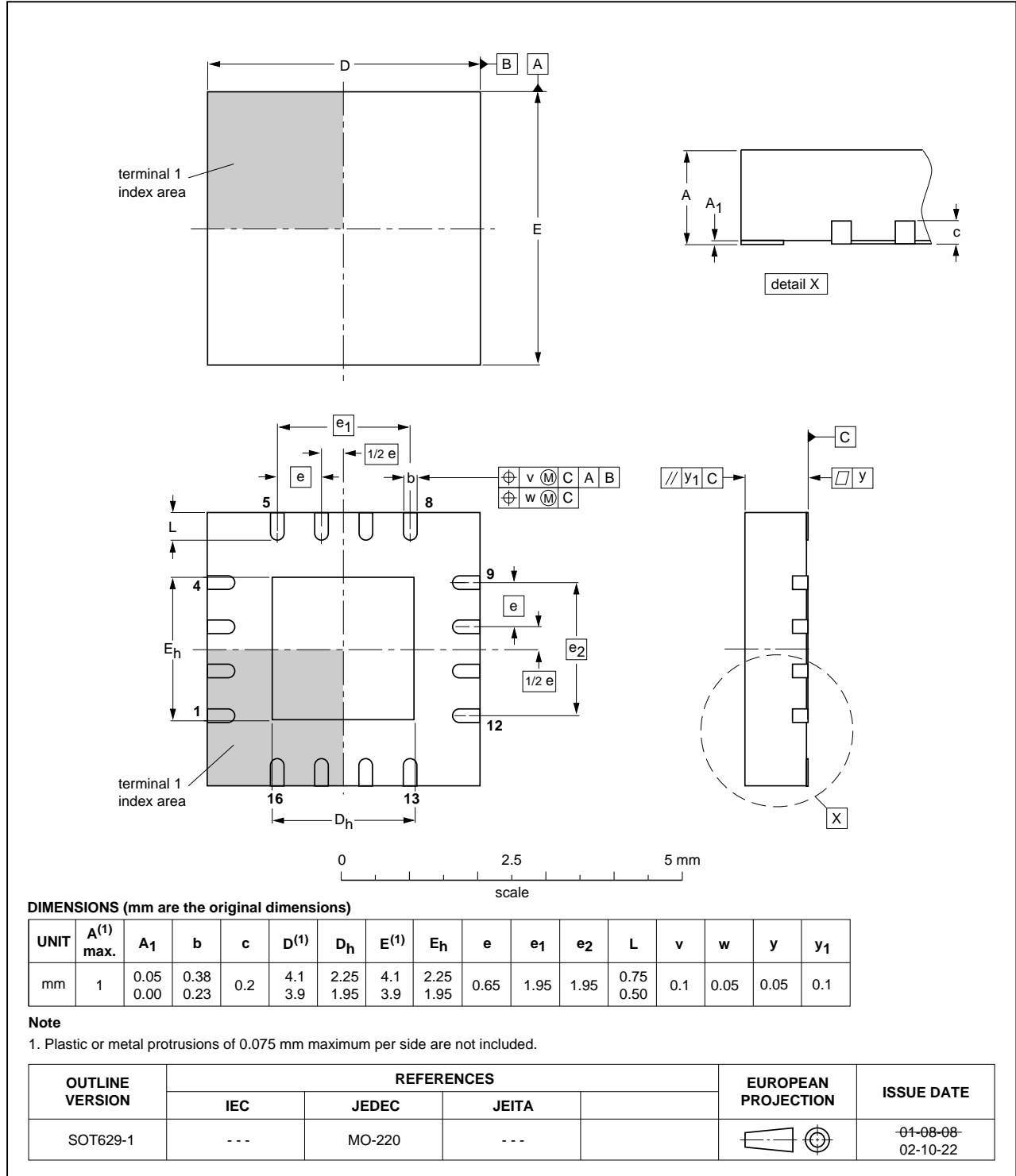

Fig 26. Package outline SOT629-1 (HVQFN16)

## 14. Soldering of SMD packages

This text provides a very brief insight into a complex technology. A more in-depth account of soldering ICs can be found in Application Note *AN10365 "Surface mount reflow soldering description"*.

### 14.1 Introduction to soldering

Soldering is one of the most common methods through which packages are attached to Printed Circuit Boards (PCBs), to form electrical circuits. The soldered joint provides both the mechanical and the electrical connection. There is no single soldering method that is ideal for all IC packages. Wave soldering is often preferred when through-hole and Surface Mount Devices (SMDs) are mixed on one printed wiring board; however, it is not suitable for fine pitch SMDs. Reflow soldering is ideal for the small pitches and high densities that come with increased miniaturization.

### 14.2 Wave and reflow soldering

Wave soldering is a joining technology in which the joints are made by solder coming from a standing wave of liquid solder. The wave soldering process is suitable for the following:

- Through-hole components
- Leaded or leadless SMDs, which are glued to the surface of the printed circuit board

Not all SMDs can be wave soldered. Packages with solder balls, and some leadless packages which have solder lands underneath the body, cannot be wave soldered. Also, leaded SMDs with leads having a pitch smaller than ~0.6 mm cannot be wave soldered, due to an increased probability of bridging.

The reflow soldering process involves applying solder paste to a board, followed by component placement and exposure to a temperature profile. Leaded packages, packages with solder balls, and leadless packages are all reflow solderable.

Key characteristics in both wave and reflow soldering are:

- Board specifications, including the board finish, solder masks and vias
- Package footprints, including solder thieves and orientation
- The moisture sensitivity level of the packages
- Package placement
- Inspection and repair
- Lead-free soldering versus SnPb soldering

### 14.3 Wave soldering

Key characteristics in wave soldering are:

- Process issues, such as application of adhesive and flux, clinching of leads, board transport, the solder wave parameters, and the time during which components are exposed to the wave
- Solder bath specifications, including temperature and impurities

## 14.4 Reflow soldering

Key characteristics in reflow soldering are:

- Lead-free versus SnPb soldering; note that a lead-free reflow process usually leads to higher minimum peak temperatures (see [Figure 27](#)) than a SnPb process, thus reducing the process window
- Solder paste printing issues including smearing, release, and adjusting the process window for a mix of large and small components on one board
- Reflow temperature profile; this profile includes preheat, reflow (in which the board is heated to the peak temperature) and cooling down. It is imperative that the peak temperature is high enough for the solder to make reliable solder joints (a solder paste characteristic). In addition, the peak temperature must be low enough that the packages and/or boards are not damaged. The peak temperature of the package depends on package thickness and volume and is classified in accordance with [Table 8](#) and [9](#)

**Table 8. SnPb eutectic process (from J-STD-020C)**

| Package thickness (mm) | Package reflow temperature (°C) |       |
|------------------------|---------------------------------|-------|
|                        | Volume (mm <sup>3</sup> )       |       |
|                        | < 350                           | ≥ 350 |
| < 2.5                  | 235                             | 220   |
| ≥ 2.5                  | 220                             | 220   |

**Table 9. Lead-free process (from J-STD-020C)**

| Package thickness (mm) | Package reflow temperature (°C) |             |        |
|------------------------|---------------------------------|-------------|--------|
|                        | Volume (mm <sup>3</sup> )       |             |        |
|                        | < 350                           | 350 to 2000 | > 2000 |
| < 1.6                  | 260                             | 260         | 260    |
| 1.6 to 2.5             | 260                             | 250         | 245    |
| > 2.5                  | 250                             | 245         | 245    |

Moisture sensitivity precautions, as indicated on the packing, must be respected at all times.

Studies have shown that small packages reach higher temperatures during reflow soldering, see [Figure 27](#).

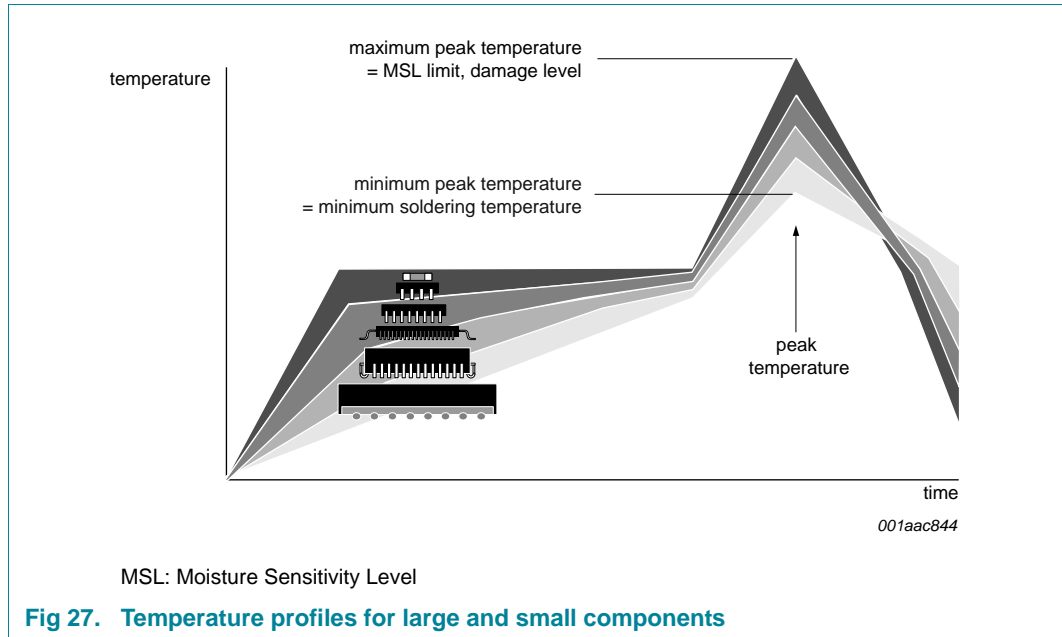

For further information on temperature profiles, refer to Application Note AN10365 “Surface mount reflow soldering description”.

## 15. Abbreviations

**Table 10. Abbreviations**

| Acronym              | Description   |
|----------------------|---|
| ASIC                 | Application Specific Integrated Circuit             |
| CBT                  | Cross-Bar Technology                                |
| CDM                  | Charged-Device Model                                |
| CPU                  | Central Processing Unit                             |
| EEPROM               | Electrically Erasable Programmable Read-Only Memory |
| ESD                  | ElectroStatic Discharge                             |
| FF                   | Flip-Flop   |
| GPIO                 | General Purpose Input/Output                        |
| I <sup>2</sup> C-bus | Inter-Integrated Circuit bus                        |
| I/O                  | Input/Output  |
| HBM                  | Human Body Model                                    |
| LED                  | Light-Emitting Diode                                |
| MM                   | Machine Model                                       |
| SMBus                | System Management Bus                               |

## 16. Revision history

Table 11. Revision history

| Document ID                   | Release date   | Data sheet status  | Change notice                    | Supersedes |
|-------------------------------|--|--------------------|----------------------------------|------------|
| PCA9500 v.4.1                 | 20170505   | Product data sheet | -                                | PCA9500_4  |
| Modifications:                | <ul style="list-style-type: none"> <li>Updated <a href="#">Section 4 "Ordering information"</a></li> </ul>   |                    |                                  |            |
| PCA9500_4                     | 20090415   | Product data sheet | -                                | PCA9500_3  |
| Modifications:                | <ul style="list-style-type: none"> <li>The format of this data sheet has been redesigned to comply with the new identity guidelines of NXP Semiconductors.</li> <li>Legal texts have been adapted to the new company name where appropriate.</li> <li><a href="#">Table 3 "Pin description"</a>: <ul style="list-style-type: none"> <li>added <a href="#">Table note [1]</a> and its reference at HVQFN16 pin 6</li> <li>changed naming convention for pins I/On to "IOn"</li> </ul> </li> <li><a href="#">Figure 7 "I/O Write mode (output)"</a>: changed symbol "t<sub>pv</sub>" to "t<sub>v(Q)</sub>"</li> <li><a href="#">Figure 8 "I/O Read mode (input)"</a>: <ul style="list-style-type: none"> <li>changed symbol "t<sub>ph</sub>" to "t<sub>h(D)</sub>"</li> <li>changed symbol "t<sub>ps</sub>" to "t<sub>su(D)</sub>"</li> </ul> </li> <li><a href="#">Table 4 "Limiting values"</a>: <ul style="list-style-type: none"> <li>changed symbol "V<sub>CC</sub>" to "V<sub>DD</sub>"</li> <li>changed parameter for I<sub>SS</sub> from "supply current" to "ground supply current"</li> <li>changed symbol "P<sub>O</sub>" to "P/out"</li> <li>changed parameter for T<sub>amb</sub> from "operating temperature" to "ambient temperature"; placed "operating" in Conditions column</li> </ul> </li> <li><a href="#">Table 5 "Static characteristics"</a>: <ul style="list-style-type: none"> <li>added reference to <a href="#">Table note [1]</a> at I<sub>OL</sub> in sub-section "I/O expander port"</li> </ul> </li> <li><a href="#">Table 6 "Dynamic characteristics"</a>: <ul style="list-style-type: none"> <li>sub-section "I<sup>2</sup>C-bus timing": changed symbol/parameter from "t<sub>SW</sub>, tolerable spike width on bus" to "t<sub>SP</sub>, pulse width of spikes that must be suppressed by the input filter"</li> <li>sub-section "Port timing": changed symbol "t<sub>pv</sub>" to "t<sub>v(Q)</sub>"</li> <li>sub-section "Port timing": changed symbol "t<sub>ps</sub>" to "t<sub>su(D)</sub>"</li> <li>sub-section "Port timing": changed symbol "t<sub>ph</sub>" to "t<sub>h(D)</sub>"</li> <li>sub-section "Power-up timing": changed symbol "t<sub>PUR</sub>" to "t<sub>pu(R)</sub>"</li> <li>sub-section "Power-up timing": changed symbol "t<sub>P UW</sub>" to "t<sub>pu(W)</sub>"</li> <li>sub-section "Write cycle limits": changed symbol "t<sub>WR</sub>" to "T<sub>cy(W)</sub>"</li> </ul> </li> <li><a href="#">Figure 23 "Write cycle timing"</a>: changed symbol "t<sub>WR</sub>" to "T<sub>cy(W)</sub>"</li> <li>added <a href="#">Section 15 "Abbreviations"</a></li> <li>updated soldering information</li> </ul> |                    |                                  |            |
| PCA9500_3<br>(9397 750 14134) | 20040930   | Product data sheet | -                                | PCA9500_2  |
| PCA9500_2                     | 20030627   | Product data       | 853-2369 30018<br>of 2003 Jun 11 | PCA9500_1  |
| PCA9500_1                     | 20020927   | Product data       | 853-2369 28875<br>of 2002 Sep 27 | -          |

## 17. Legal information

### 17.1 Data sheet status

| Document status <sup>[1][2]</sup> | Product status <sup>[3]</sup> | Definition  |
|-----------------------------------|-------------------------------|---|
| Objective [short] data sheet      | Development                   | This document contains data from the objective specification for product development. |
| Preliminary [short] data sheet    | Qualification                 | This document contains data from the preliminary specification.                       |
| Product [short] data sheet        | Production                    | This document contains the product specification.                                     |

[1] Please consult the most recently issued document before initiating or completing a design.

[2] The term 'short data sheet' is explained in section "Definitions".

[3] The product status of device(s) described in this document may have changed since this document was published and may differ in case of multiple devices. The latest product status information is available on the Internet at URL <http://www.nxp.com>.

### 17.2 Definitions

**Draft** — The document is a draft version only. The content is still under internal review and subject to formal approval, which may result in modifications or additions. NXP Semiconductors does not give any representations or warranties as to the accuracy or completeness of information included herein and shall have no liability for the consequences of use of such information.

**Short data sheet** — A short data sheet is an extract from a full data sheet with the same product type number(s) and title. A short data sheet is intended for quick reference only and should not be relied upon to contain detailed and full information. For detailed and full information see the relevant full data sheet, which is available on request via the local NXP Semiconductors sales office. In case of any inconsistency or conflict with the short data sheet, the full data sheet shall prevail.

**Product specification** — The information and data provided in a Product data sheet shall define the specification of the product as agreed between NXP Semiconductors and its customer, unless NXP Semiconductors and customer have explicitly agreed otherwise in writing. In no event however, shall an agreement be valid in which the NXP Semiconductors product is deemed to offer functions and qualities beyond those described in the Product data sheet.

### 17.3 Disclaimers

**Limited warranty and liability** — Information in this document is believed to be accurate and reliable. However, NXP Semiconductors does not give any representations or warranties, expressed or implied, as to the accuracy or completeness of such information and shall have no liability for the consequences of use of such information. NXP Semiconductors takes no responsibility for the content in this document if provided by an information source outside of NXP Semiconductors.

In no event shall NXP Semiconductors be liable for any indirect, incidental, punitive, special or consequential damages (including - without limitation - lost profits, lost savings, business interruption, costs related to the removal or replacement of any products or rework charges) whether or not such damages are based on tort (including negligence), warranty, breach of contract or any other legal theory.

Notwithstanding any damages that customer might incur for any reason whatsoever, NXP Semiconductors' aggregate and cumulative liability towards customer for the products described herein shall be limited in accordance with the *Terms and conditions of commercial sale* of NXP Semiconductors.

**Right to make changes** — NXP Semiconductors reserves the right to make changes to information published in this document, including without limitation specifications and product descriptions, at any time and without notice. This document supersedes and replaces all information supplied prior to the publication hereof.

**Suitability for use** — NXP Semiconductors products are not designed, authorized or warranted to be suitable for use in life support, life-critical or safety-critical systems or equipment, nor in applications where failure or malfunction of an NXP Semiconductors product can reasonably be expected to result in personal injury, death or severe property or environmental damage. NXP Semiconductors and its suppliers accept no liability for inclusion and/or use of NXP Semiconductors products in such equipment or applications and therefore such inclusion and/or use is at the customer's own risk.

**Applications** — Applications that are described herein for any of these products are for illustrative purposes only. NXP Semiconductors makes no representation or warranty that such applications will be suitable for the specified use without further testing or modification.

Customers are responsible for the design and operation of their applications and products using NXP Semiconductors products, and NXP Semiconductors accepts no liability for any assistance with applications or customer product design. It is customer's sole responsibility to determine whether the NXP Semiconductors product is suitable and fit for the customer's applications and products planned, as well as for the planned application and use of customer's third party customer(s). Customers should provide appropriate design and operating safeguards to minimize the risks associated with their applications and products.

NXP Semiconductors does not accept any liability related to any default, damage, costs or problem which is based on any weakness or default in the customer's applications or products, or the application or use by customer's third party customer(s). Customer is responsible for doing all necessary testing for the customer's applications and products using NXP Semiconductors products in order to avoid a default of the applications and the products or of the application or use by customer's third party customer(s). NXP does not accept any liability in this respect.

**Limiting values** — Stress above one or more limiting values (as defined in the Absolute Maximum Ratings System of IEC 60134) will cause permanent damage to the device. Limiting values are stress ratings only and (proper) operation of the device at these or any other conditions above those given in the Recommended operating conditions section (if present) or the Characteristics sections of this document is not warranted. Constant or repeated exposure to limiting values will permanently and irreversibly affect the quality and reliability of the device.

**Terms and conditions of commercial sale** — NXP Semiconductors products are sold subject to the general terms and conditions of commercial sale, as published at <http://www.nxp.com/profile/terms>, unless otherwise agreed in a valid written individual agreement. In case an individual agreement is concluded only the terms and conditions of the respective agreement shall apply. NXP Semiconductors hereby expressly objects to applying the customer's general terms and conditions with regard to the purchase of NXP Semiconductors products by customer.

**No offer to sell or license** — Nothing in this document may be interpreted or construed as an offer to sell products that is open for acceptance or the grant, conveyance or implication of any license under any copyrights, patents or other industrial or intellectual property rights.

**Export control** — This document as well as the item(s) described herein may be subject to export control regulations. Export might require a prior authorization from competent authorities.

**Quick reference data** — The Quick reference data is an extract of the product data given in the Limiting values and Characteristics sections of this document, and as such is not complete, exhaustive or legally binding.

**Non-automotive qualified products** — Unless this data sheet expressly states that this specific NXP Semiconductors product is automotive qualified, the product is not suitable for automotive use. It is neither qualified nor tested in accordance with automotive testing or application requirements. NXP Semiconductors accepts no liability for inclusion and/or use of non-automotive qualified products in automotive equipment or applications.

In the event that customer uses the product for design-in and use in automotive applications to automotive specifications and standards, customer (a) shall use the product without NXP Semiconductors' warranty of the product for such automotive applications, use and specifications, and (b)

whenever customer uses the product for automotive applications beyond NXP Semiconductors' specifications such use shall be solely at customer's own risk, and (c) customer fully indemnifies NXP Semiconductors for any liability, damages or failed product claims resulting from customer design and use of the product for automotive applications beyond NXP Semiconductors' standard warranty and NXP Semiconductors' product specifications.

**Translations** — A non-English (translated) version of a document is for reference only. The English version shall prevail in case of any discrepancy between the translated and English versions.

## 17.4 Trademarks

Notice: All referenced brands, product names, service names and trademarks are the property of their respective owners.

**I<sup>2</sup>C-bus** — logo is a trademark of NXP Semiconductors N.V.

## 18. Contact information

For more information, please visit: <http://www.nxp.com>

For sales office addresses, please send an email to: [salesaddresses@nxp.com](mailto:salesaddresses@nxp.com)

## 19. Contents

|           |  |           |           |                                  |           |
|-----------|--|-----------|-----------|----------------------------------|-----------|
| <b>1</b>  | <b>General description</b> .....                       | <b>1</b>  | <b>18</b> | <b>Contact information</b> ..... | <b>28</b> |
| <b>2</b>  | <b>Features and benefits</b> .....                     | <b>1</b>  | <b>19</b> | <b>Contents</b> .....            | <b>29</b> |
| <b>3</b>  | <b>Applications</b> .....                              | <b>2</b>  |           |                                  |           |
| <b>4</b>  | <b>Ordering information</b> .....                      | <b>3</b>  |           |                                  |           |
| 4.1       | Ordering options .....                                 | 3         |           |                                  |           |
| <b>5</b>  | <b>Block diagram</b> .....                             | <b>4</b>  |           |                                  |           |
| <b>6</b>  | <b>Pinning information</b> .....                       | <b>5</b>  |           |                                  |           |
| 6.1       | Pinning .....  | 5         |           |                                  |           |
| 6.2       | Pin description .....                                  | 5         |           |                                  |           |
| <b>7</b>  | <b>Functional description</b> .....                    | <b>7</b>  |           |                                  |           |
| 7.1       | Device addressing .....                                | 7         |           |                                  |           |
| 7.2       | Control register .....                                 | 7         |           |                                  |           |
| 7.3       | I/O operations .....                                   | 8         |           |                                  |           |
| 7.3.1     | Quasi-bidirectional I/Os .....                         | 9         |           |                                  |           |
| 7.4       | Memory operations .....                                | 9         |           |                                  |           |
| 7.4.1     | Write operations .....                                 | 9         |           |                                  |           |
| 7.4.1.1   | Byte write .....                                       | 9         |           |                                  |           |
| 7.4.1.2   | Page write .....                                       | 10        |           |                                  |           |
| 7.4.2     | Read operations .....                                  | 10        |           |                                  |           |
| 7.4.2.1   | Current address read .....                             | 10        |           |                                  |           |
| 7.4.2.2   | Random read .....                                      | 11        |           |                                  |           |
| 7.4.2.3   | Sequential read .....                                  | 11        |           |                                  |           |
| <b>8</b>  | <b>Characteristics of the I<sup>2</sup>C-bus</b> ..... | <b>12</b> |           |                                  |           |
| 8.1       | Bit transfer .....                                     | 12        |           |                                  |           |
| 8.1.1     | START and STOP conditions .....                        | 12        |           |                                  |           |
| 8.2       | System configuration .....                             | 13        |           |                                  |           |
| 8.3       | Acknowledge .....                                      | 13        |           |                                  |           |
| <b>9</b>  | <b>Application design-in information</b> .....         | <b>14</b> |           |                                  |           |
| <b>10</b> | <b>Limiting values</b> .....                           | <b>15</b> |           |                                  |           |
| <b>11</b> | <b>Static characteristics</b> .....                    | <b>16</b> |           |                                  |           |
| <b>12</b> | <b>Dynamic characteristics</b> .....                   | <b>18</b> |           |                                  |           |
| <b>13</b> | <b>Package outline</b> .....                           | <b>20</b> |           |                                  |           |
| <b>14</b> | <b>Soldering of SMD packages</b> .....                 | <b>23</b> |           |                                  |           |
| 14.1      | Introduction to soldering .....                        | 23        |           |                                  |           |
| 14.2      | Wave and reflow soldering .....                        | 23        |           |                                  |           |
| 14.3      | Wave soldering .....                                   | 23        |           |                                  |           |
| 14.4      | Reflow soldering .....                                 | 24        |           |                                  |           |
| <b>15</b> | <b>Abbreviations</b> .....                             | <b>25</b> |           |                                  |           |
| <b>16</b> | <b>Revision history</b> .....                          | <b>26</b> |           |                                  |           |
| <b>17</b> | <b>Legal information</b> .....                         | <b>27</b> |           |                                  |           |
| 17.1      | Data sheet status .....                                | 27        |           |                                  |           |
| 17.2      | Definitions .....                                      | 27        |           |                                  |           |
| 17.3      | Disclaimers .....                                      | 27        |           |                                  |           |
| 17.4      | Trademarks .....                                       | 28        |           |                                  |           |

Please be aware that important notices concerning this document and the product(s) described herein, have been included in section 'Legal information'.

© NXP Semiconductors N.V. 2017.

All rights reserved.

For more information, please visit: <http://www.nxp.com>

For sales office addresses, please send an email to: [salesaddresses@nxp.com](mailto:salesaddresses@nxp.com)

Date of release: 5 May 2017

Document identifier: PCA9500

## Looking for pricing, stock, or lifecycle information?

Click below to explore more details on WIN SOURCE:

 [View PCA9500D,118 on WIN SOURCE](#)

 [NXP / Nexperia Information](#)

## Optimize Your Supply Chain with WIN SOURCE Solutions

-  Global Sourcing Solution
-  Obsolete Management
-  Cost Control Management
-  Shortage Management
-  Alternative Solution
-  Excess Inventory Management