



THE DATASHEET OF MM74HC574MTC



3-State Octal D-Type Edge-Triggered Flip-Flop

MM74HC574

The MM74HC574 high speed octal D-type flip-flops utilize advanced silicon-gate P-well CMOS technology. They possess the high noise immunity and low power consumption of standard CMOS integrated circuits, as well as the ability to drive 15 LS-TTL loads. Due to the large output drive capability and the 3-STATE feature, these devices are ideally suited for interfacing with bus lines in a bus organized system.

These devices are positive edge triggered flip-flops. Data at the D inputs, meeting the set-up and hold time requirements, are transferred to the Q outputs on positive going transitions of the CLOCK (CK) input. When a high logic level is applied to the OUTPUT CONTROL (OC) input, all outputs go to a high impedance state, regardless of what signals are present at the other inputs and the state of the storage elements.

The 74HC logic family is speed, function, and pinout compatible with the standard 74LS logic family. All inputs are protected from damage due to static discharge by internal diode clamps to V_{CC} and ground.

Features

- Typical Propagation Delay: 17 ns
- Wide Operating Voltage Range: 2 V – 6 V
- Low Input Current: 1 μA Maximum
- Low Quiescent Current: 160 μA Maximum
- Compatible with Bus-oriented Systems
- Output Drive Capability: 15 LS-TTL Loads
- This is a Pb-Free Device

MAXIMUM RATINGS (Note 1)

Rating	Symbol	Value	Unit
Supply Voltage	V _{CC}	-0.5 to + 7.0 V	V
DC Input Voltage	V _{IN}	-0.5 to V _{CC} + 0.5 V	V
DC Output Voltage	V _{OUT}	-0.5 to V _{CC} + 0.5 V	V
Clamp Diode Current	I _{IK} , I _{OK}	±20	mA
DC Output Current, per pin	I _{OUT}	±35	mA
DC V _{CC} or GND Current, per pin	I _{CC}	±70	mA
Storage Temperature Range	T _{STG}	-65 to +150	°C
Power Dissipation S.O. Package only	P _D	500	mW
Lead Temperature (Soldering 10 s)	T _L	260	°C

Stresses exceeding those listed in the Maximum Ratings table may damage the device. If any of these limits are exceeded, device functionality should not be assumed, damage may occur and reliability may be affected.

1. Unless otherwise specified all voltages are referenced to ground.

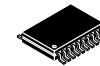

TSSOP20
MTC SUFFIX
CASE 948AQ

MARKING DIAGRAM

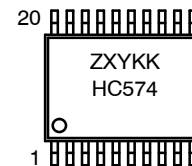

HC574 = Specific Device Code
Z = Assembly Plant Code
XY = Data Code (Year & Week)
KK = Lot Traceability Code

CONNECTION DIAGRAM

Pin Assignments

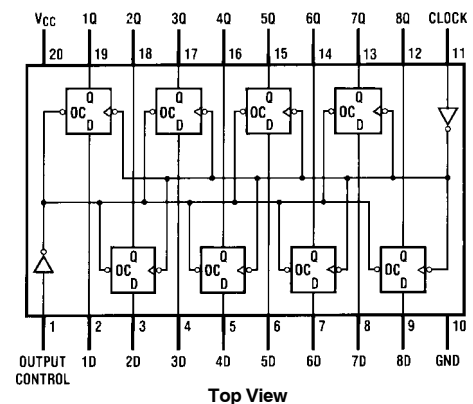

TRUTH TABLE

Output Control	Clock	Data	Output
L	↑	H	H
L	↑	L	L
L	L	X	Q ₀
H	X	X	Z

H = HIGH Level
L = LOW Level
X = Don't Care
↑ = Transition from Low-to-HIGH
Z = High Impedance State
Q₀ = The level of the output before steady state input conditions were established

ORDERING INFORMATION

See detailed ordering and shipping information in the package dimensions section on page 4 of this data sheet.

MM74HC574

RECOMMENDED OPERATING CONDITIONS

Symbol	Characteristic	Min	Typ	Max	Units
V_{CC}	Supply Voltage	2		6	V
V_{IN}, V_{OUT}	DC Input or Output Voltage	0		V_{CC}	V
T_A	Operating Temperature Range	-55		+125	°C
t_r, t_f	Input Rise or Fall Times			$V_{CC} = 2.0\text{ V}$ $V_{CC} = 4.5\text{ V}$ $V_{CC} = 6.0\text{ V}$	1000 500 400 ns

Functional operation above the stresses listed in the Recommended Operating Ranges is not implied. Extended exposure to stresses beyond the Recommended Operating Ranges limits may affect device reliability.

DC ELECTRICAL CHARACTERISTICS (Note 2)

Symbol	Parameter	Conditions	V_{CC}	$T_A = 25^\circ\text{C}$		$T_A = -40\text{ to }85^\circ\text{C}$		$T_A = -55\text{ to }125^\circ\text{C}$		Units
				Typ	Guaranteed Limits					
V_{IH}	Minimum HIGH Level Input Voltage		2.0 V		1.5	1.5	1.5		V	
			4.5 V		3.15	3.15	3.15			
			6.0 V		4.2	4.2	4.2			
V_{IL}	Maximum LOW Level Input Voltage		2.0 V		0.5	0.5	0.5		V	
			4.5 V		1.35	1.35	1.35			
			6.0 V		1.8	1.8	1.8			
V_{OH}	Minimum HIGH Level Output Voltage	$V_{IN} = V_{IH}$ or V_{IL} $ I_{OUT} \leq 20\ \mu\text{A}$	2.0 V	2.0	1.9	1.9	1.9	V		
			4.5 V	4.5	4.4	4.4	4.4			
		6.0 V	6.0	5.9	5.9	5.9				
		$V_{IN} = V_{IH}$ or V_{IL} $ I_{OUT} \leq 6.0\text{ mA}$ $ I_{OUT} \leq 7.8\text{ mA}$	4.5 V	4.2	3.98	3.84	3.7	V		
6.0 V	5.7		5.48	5.34	5.2					
V_{OL}	Maximum LOW Level Output Voltage	$V_{IN} = V_{IH}$ or V_{IL} $ I_{OUT} \leq 20\ \mu\text{A}$	2.0 V	0	0.1	0.1	0.1	V		
			4.5 V	0	0.1	0.1	0.1			
		6.0 V	0	0.1	0.1	0.1				
		$V_{IN} = V_{IH}$ or V_{IL} $ I_{OUT} \leq 6.0\text{ mA}$ $ I_{OUT} \leq 7.8\text{ mA}$	4.5 V	0.2	0.26	0.33	0.4	V		
6.0 V	0.2		0.26	0.33	0.4					
I_{IN}	Maximum Input Current	$V_{IN} = V_{CC}$ or GND	6.0 V		± 0.1	± 1.0	± 1.0	μA		
I_{OZ}	Maximum 3-STATE Output Leakage Current	$V_{OUT} = V_{CC}$ or GND $OC = V_{IH}$	6.0 V		± 0.5	± 5.0	± 10	μA		
I_{CC}	Maximum Quiescent Supply Current	$V_{IN} = V_{CC}$ or GND $I_{OUT} = 0\ \mu\text{A}$	6.0 V		8.0	80	160	μA		
ΔI_{CC}	Quiescent Supply Current per Input Pin	$V_{CC} = 5.5\text{ V}$ $V_{IN} = 2.4\text{ V}$ or 0.4 V (Note 2)	OE	1.0	1.5	1.8	2.0	mA		
			CLK	0.6	0.8	1.0	1.1			
			DATA	0.4	0.5	0.6	0.7			

Product parametric performance is indicated in the Electrical Characteristics for the listed test conditions, unless otherwise noted. Product performance may not be indicated by the Electrical Characteristics if operated under different conditions.

2. For a power supply of $5\text{ V} \pm 10\%$ the worst-case output voltages (V_{OH} , and V_{OL}) occur for HC at 4.5 V. Thus the 4.5 V values should be used when designing with this supply. Worst-case V_{IH} and V_{IL} occur at $V_{CC} = 5.5\text{ V}$ and 4.5 V respectively. (The V_{IH} value at 5.5 V is 3.85 V.) The worst-case leakage current (I_{IN} , I_{CC} , and I_{OZ}) occur for CMOS at the higher voltage and so the 6.0 V values should be used.

AC ELECTRICAL CHARACTERISTICS ($V_{CC} = 5\text{ V}$, $T_A = 25^\circ\text{C}$, $t_r = t_f = 6\text{ ns}$)

Symbol	Parameter	Conditions	Typ	Guaranteed Limit	Units
f_{MAX}	Maximum Operating Frequency		60	33	MHz
t_{PHL}, t_{PLH}	Maximum Propagation Delay, Clock to Q	$C_L = 45\text{ pF}$	17	27	ns
t_{PZH}, t_{PZL}	Maximum Output Enable Time	$R_L = 1\text{ k}\Omega$, $C_L = 45\text{ pF}$	19	28	ns
t_{PHZ}, t_{PLZ}	Maximum Output Disable Time	$R_L = 1\text{ k}\Omega$, $C_L = 5\text{ pF}$	14	25	ns

MM74HC574

AC ELECTRICAL CHARACTERISTICS ($V_{CC} = 5\text{ V}$, $T_A = 25^\circ\text{C}$, $t_r = t_f = 6\text{ ns}$)

Symbol	Parameter	Conditions	Typ	Guaranteed Limit	Units
t_S	Minimum Setup Time, Data to Clock		10	12	ns
t_H	Minimum Hold Time, Clock to Data		-3	5	ns
t_W	Minimum Pulse Clock Width		8	15	ns

AC ELECTRICAL CHARACTERISTICS ($V_{CC} = 2.0 - 6.0\text{ V}$, $C_L = 50\text{ pF}$, $t_r = t_f = 6\text{ ns}$ unless otherwise specified)

Symbol	Parameter	Conditions	V_{CC}	$T_A = 25^\circ\text{C}$		$T_A = -40\text{ to }85^\circ\text{C}$	$T_A = -55\text{ to }125^\circ\text{C}$	Units
				Typ	Guaranteed Limits			
f_{MAX}	Maximum Operating Frequency	$C_L = 50\text{ pF}$	2.0 V 4.5 V 6.0 V		33 30 35	28 24 28	23 20 23	MHz
t_{PHL} , t_{PLH}	Maximum Propagation Delay, Clock to Q	$C_L = 50\text{ pF}$ $C_L = 150\text{ pF}$	2.0 V	18	30	38	45	ns
			2.0 V	51	155	194	233	
			4.5 V 4.5 V	13 19	23 31	29 47	35 47	
6.0 V 6.0 V	12 18	20 27	25 34	30 41	ns			
t_{PZH} , t_{PLZ}	Maximum Output Enable Time	$R_L = 1\text{ k}\Omega$ $C_L = 50\text{ pF}$ $C_L = 150\text{ pF}$	2.0 V	22	30	38	45	ns
			2.0 V	59	180	225	270	
			4.5 V 4.5 V	14 20	28 36	35 45	42 54	
6.0 V 6.0 V	12 18	24 31	30 39	36 47	ns			
t_{PHZ} , t_{PLZ}	Maximum Output Disable Time	$R_L = 1\text{ k}\Omega$ $C_L = 50\text{ pF}$	2.0 V	15	30	38	45	ns
			4.5 V	12	25	31	38	
			6.0 V	10	21	27	32	
t_S	Minimum Setup Time Data to Clock		2.0 V	6	12	15	18	ns
			4.5 V		20	25	30	
			6.0 V		17	21	25	
t_H	Minimum Hold Time Clock to Data		2.0 V	-1	5	6	8	ns
			4.5 V		0	0	0	
			6.0 V		0	0	0	
t_{THL} , t_{TLH}	Maximum Output Rise and Fall Time	$C_L = 50\text{ pF}$	2.0 V	6	12	15	18	ns
			4.5 V	7	12	15	18	
			6.0 V	6	10	13	15	
t_W	Minimum Clock Pulse Width		2.0 V	30	15	20	24	ns
			4.5 V	9	16	20	24	
			6.0 V	8	14	18	20	
t_r , t_f	Maximum Clock Input Rise and Fall Time		2.0 V		1000	1000	1000	ns
			4.5 V		500	500	500	
			6.0 V		400	400	400	
C_{PD}		$OC = V_{CC}$ $OC = GND$		5 58				pF
C_{IN}	Maximum Input Capacitance			5	10	10	10	pF
C_{OUT}	Maximum Output Capacitance			15	20	20	20	pF

3. C_{PD} determines the no load dynamic power consumption, $P_D = C_{PD} V_{CC}^2 f + I_{CC} V_{CC}$, and the no load dynamic current consumption, $I_S = C_{PD} V_{CC} f + I_{CC}$.

MM74HC574

ORDERING INFORMATION

Order Number	Package	Shipping†
MM74HC574MTCX	TSSOP-20	2500 Units / Tape & Reel
MM74HC574MTC	TSSOP-20	1825 Units / Tube

†For information on tape and reel specifications, including part orientation and tape sizes, please refer to our Tape and Reel Packaging Specifications Brochure, [BRD8011/D](#).

TSSOP20, 4.4x6.5
CASE 948AQ
ISSUE A

DATE 19 MAR 2009

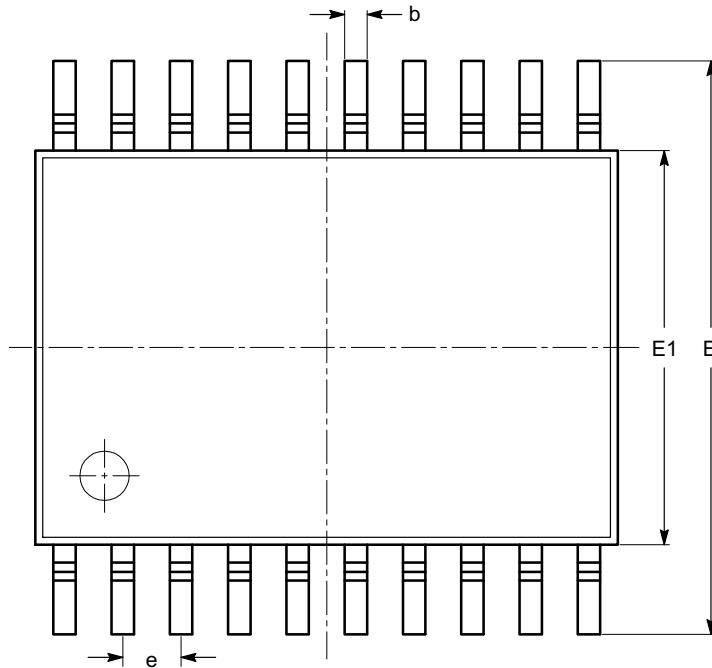

TOP VIEW

SYMBOL	MIN	NOM	MAX
A			1.20
A1	0.05		0.15
A2	0.80		1.05
b	0.19		0.30
c	0.09		0.20
D	6.40	6.50	6.60
E	6.30	6.40	6.50
E1	4.30	4.40	4.50
e	0.65 BSC		
L	0.45	0.60	0.75
L1	1.00 REF		
θ	0°		8°

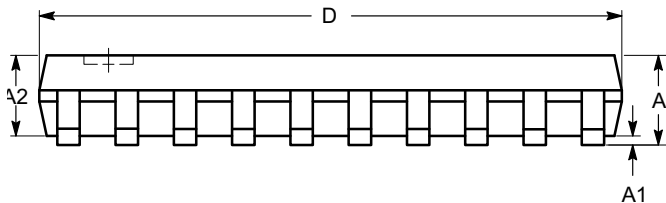

SIDE VIEW

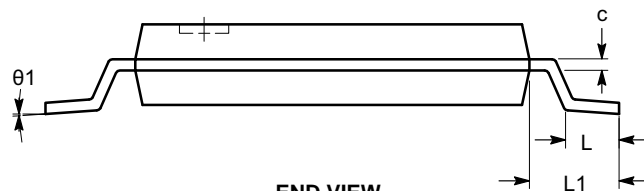

END VIEW

Notes:

- (1) All dimensions are in millimeters. Angles in degrees.
- (2) Complies with JEDEC MO-153.

DOCUMENT NUMBER:	98AON34453E	Electronic versions are uncontrolled except when accessed directly from the Document Repository. Printed versions are uncontrolled except when stamped "CONTROLLED COPY" in red.
DESCRIPTION:	TSSOP20, 4.4X6.5	PAGE 1 OF 1

onsemi and ONSEMI are trademarks of Semiconductor Components Industries, LLC dba onsemi or its subsidiaries in the United States and/or other countries. onsemi reserves the right to make changes without further notice to any products herein. onsemi makes no warranty, representation or guarantee regarding the suitability of its products for any particular purpose, nor does onsemi assume any liability arising out of the application or use of any product or circuit, and specifically disclaims any and all liability, including without limitation special, consequential or incidental damages. onsemi does not convey any license under its patent rights nor the rights of others.

onsemi, **Onsemi**, and other names, marks, and brands are registered and/or common law trademarks of Semiconductor Components Industries, LLC dba "**onsemi**" or its affiliates and/or subsidiaries in the United States and/or other countries. **onsemi** owns the rights to a number of patents, trademarks, copyrights, trade secrets, and other intellectual property. A listing of **onsemi**'s product/patent coverage may be accessed at www.onsemi.com/site/pdf/Patent-Marking.pdf. **onsemi** reserves the right to make changes at any time to any products or information herein, without notice. The information herein is provided "as-is" and **onsemi** makes no warranty, representation or guarantee regarding the accuracy of the information, product features, availability, functionality, or suitability of its products for any particular purpose, nor does **onsemi** assume any liability arising out of the application or use of any product or circuit, and specifically disclaims any and all liability, including without limitation special, consequential or incidental damages. Buyer is responsible for its products and applications using **onsemi** products, including compliance with all laws, regulations and safety requirements or standards, regardless of any support or applications information provided by **onsemi**. "Typical" parameters which may be provided in **onsemi** data sheets and/or specifications can and do vary in different applications and actual performance may vary over time. All operating parameters, including "Typicals" must be validated for each customer application by customer's technical experts. **onsemi** does not convey any license under any of its intellectual property rights nor the rights of others. **onsemi** products are not designed, intended, or authorized for use as a critical component in life support systems or any FDA Class 3 medical devices or medical devices with a same or similar classification in a foreign jurisdiction or any devices intended for implantation in the human body. Should Buyer purchase or use **onsemi** products for any such unintended or unauthorized application, Buyer shall indemnify and hold **onsemi** and its officers, employees, subsidiaries, affiliates, and distributors harmless against all claims, costs, damages, and expenses, and reasonable attorney fees arising out of, directly or indirectly, any claim of personal injury or death associated with such unintended or unauthorized use, even if such claim alleges that **onsemi** was negligent regarding the design or manufacture of the part. **onsemi** is an Equal Opportunity/Affirmative Action Employer. This literature is subject to all applicable copyright laws and is not for resale in any manner.

ADDITIONAL INFORMATION

TECHNICAL PUBLICATIONS:



Technical Library: www.onsemi.com/design/resources/technical-documentation
onsemi Website: www.onsemi.com

ONLINE SUPPORT: www.onsemi.com/support

For additional information, please contact your local Sales Representative at www.onsemi.com/support/sales

Looking for pricing, stock, or lifecycle information?

Click below to explore more details on WIN SOURCE:

-  View [MM74HC574MTC](#) on WIN SOURCE
-  [ON Semiconductor](#) Information

Optimize Your Supply Chain with WIN SOURCE Solutions

-  Global Sourcing Solution
-  Obsolete Management
-  Cost Control Management
-  Shortage Management
-  Alternative Solution
-  Excess Inventory Management