

# IP4853CX24

SD, MMC and microSD memory card integrated level shifter  
with PSU, EMI filter and ESD protection

Rev. 3 — 30 September 2010

Product data sheet

## 1. Product profile

---

### 1.1 General description

The IP4853CX24 is a device that fully integrates a bidirectional level shifter or voltage translator, ElectroMagnetic Interference (EMI) filter and ElectroStatic Discharge (ESD) protection diodes. It is specifically designed to be used for memory card interfaces such as Secure Digital (SD), microSD and Multi Media Card (MMC) memory cards.

The integrated Power Supply Unit (PSU) supplies memory cards with 2.9 V directly from the battery. This enables a 1.8 V operating host-side device (e.g. a processor interface) to communicate with a 2.9 V compliant memory card using its integrated level shifter. Radiation from digital signals in the higher harmonics, close to typical mobile phone frequencies, is suppressed by the EMI filter.

The IP4853CX24 is fabricated using monolithic silicon technology in a Wafer Level Chip-Size Package (WLCSP) with 0.4 mm pitch.

### 1.2 Features and benefits

- Pb-free, Restriction of Hazardous Substances (RoHS) compliant and free of halogen and antimony (Dark Green compliant)
- Integrated EMI filters
- Feedback channel for clock synchronization
- Integrated ESD protection according to IEC 61000-4-2, level 4
- WLCSP with 0.4 mm pitch

### 1.3 Applications

- SD-memory card, microSD-memory card and MMC interfaces in latest electronic appliances such as:
  - ◆ Mobile phone or smart phone
  - ◆ Digital camera
  - ◆ Card reader in (laptop) computer
- Appliances requiring one or several of the following features:
  - ◆ Level shifting and voltage translation from 1.8 V to 2.9 V and from 2.9 V to 1.8 V
  - ◆ ESD protection according to IEC 61000-4-2, level 4
  - ◆ Power supply regulation from battery to 2.9 V card memory voltage
  - ◆ EMI filtering
  - ◆ Integration of interface-specific biasing resistor network



## 2. Pinning information

### 2.1 Pinning

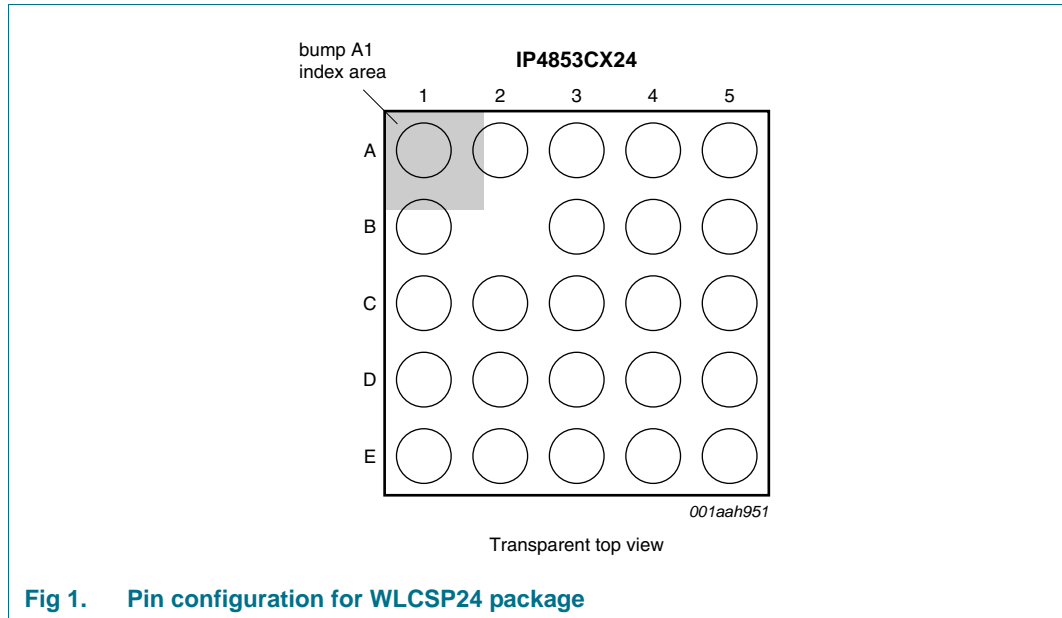

Fig 1. Pin configuration for WLCSP24 package

Table 1. Pin allocation table

Pin	Symbol	Pin	Symbol	Pin	Symbol	Pin	Symbol	Pin	Symbol
A1	DATA2_H	A2	DIR_CMD	A3	DIR_0	A4	V <sub>BAT</sub>	A5	DATA2_SD
B1	DATA3_H	B2	n.c.	B3	V <sub>CC</sub>	B4	VSD	B5	DATA3_SD
C1	CLK_IN	C2	ENABLE	C3	GND	C4	GND	C5	CLK_SD
D1	DATA0_H	D2	CMD_H	D3	CD	D4	CMD_SD	D5	DATA0_SD
E1	DATA1_H	E2	CLK_FB	E3	DIR_1_3	E4	WP	E5	DATA1_SD

### 2.2 Pin description

Table 2. Pin description

Symbol <sup>[1]</sup>	Pin	Type <sup>[2]</sup>	Description
DATA2_H	A1	I/O	data 2 input or output on host side
DIR_CMD	A2	I	direction control input for command
DIR_0	A3	I	direction control input for data 0
V <sub>BAT</sub>	A4	S	supply voltage from battery for regulator
DATA2_SD	A5	I/O	data 2 input or output on memory card side
DATA3_H	B1	I/O	data 3 input or output on host side
n.c.	B2	-	not connected
V <sub>CC</sub>	B3	S	supply voltage for host-side circuits
VSD	B4	O	output supply voltage for memory card
DATA3_SD	B5	I/O	data 3 input or output on memory card side
CLK_IN	C1	I	clock signal input

Table 2. Pin description ...continued

Symbol <sup>[1]</sup>	Pin	Type <sup>[2]</sup>	Description
ENABLE	C2	I	device enable input
GND	C3	S	supply ground
GND	C4	S	supply ground
CLK_SD	C5	O	clock signal output on memory card side
DATA0_H	D1	I/O	data 0 input or output on host side
CMD_H	D2	I/O	command input or output on host side
CD	D3	O	card detect switch biasing output
CMD_SD	D4	I/O	command input or output on memory card side
DATA0_SD	D5	I/O	data 0 input or output on memory card side
DATA1_H	E1	I/O	data 1 input or output on host side
CLK_FB	E2	O	clock feedback output to host
DIR_1_3	E3	I	direction control input for data 1, data 2 and data 3
WP	E4	O	write protect switch biasing output
DATA1_SD	E5	I/O	data 1 input or output on memory card side

[1] The pin names relate particularly to SD-memory cards, but also apply to microSD-memory cards and MMC.

[2] I = input, O = output, I/O = input and output, S = power supply.

### 3. Ordering information

Table 3. Ordering information

Type number	Package		Version
	Name	Description	
IP4853CX24/P	WLCSP24	wafer level chip-size package; 24 bumps; 1.99 × 1.99 × 0.61 mm	IP4853CX24/P

4. Block diagram

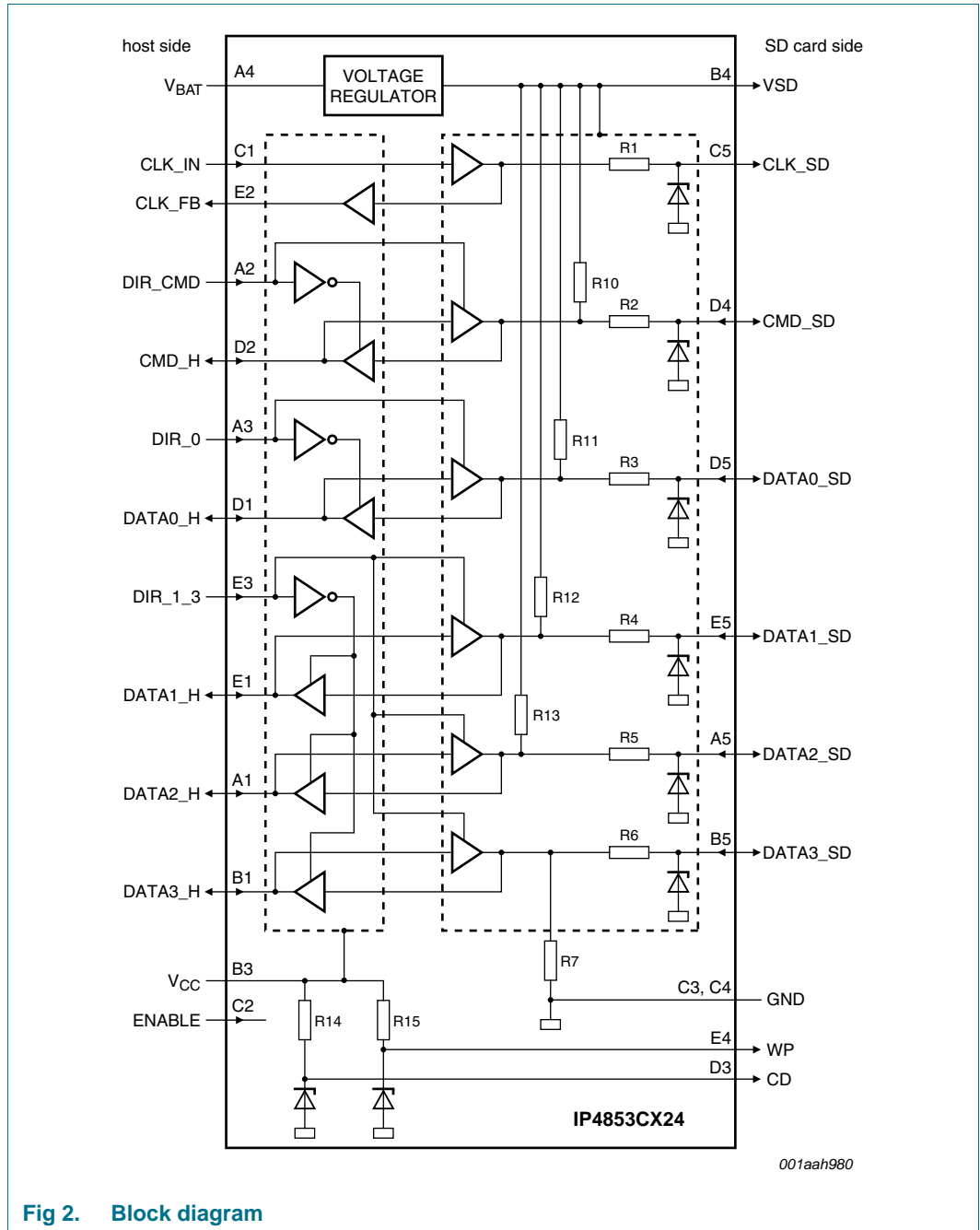

Fig 2. Block diagram

## 5. Functional description

### 5.1 Logic control signals

Table 4. Control signal truth table

$V_{BAT} \geq 2.7 V$ .

Control		Host side		Memory card side	
Pin	Level <sup>[1]</sup>	Pin	Function	Pin	Function
<b>Pin ENABLE = HIGH and <math>V_{CC} \geq 1.62 V</math></b>					
DIR_CMD	H	CMD_H	input	CMD_SD	output
	L	CMD_H	output	CMD_SD	input
DIR_0	H	DATA0_H	input	DATA0_SD	output
	L	DATA0_H	output	DATA0_SD	input
DIR_1_3	H	DATA1_H, DATA2_H, DATA3_H	input	DATA1_SD, DATA2_SD, DATA3_SD	output
	L	DATA1_H, DATA2_H, DATA3_H	output	DATA1_SD, DATA2_SD, DATA3_SD	input
-	-	CLK_FB	output	CLK_SD	output
<b>Pin ENABLE = LOW or <math>V_{CC} \leq 0.8 V</math></b>					
DIR_CMD	X	CMD_H	high-Z	CMD_SD	high-Z
DIR_0	X	DATA0_H	high-Z	DATA0_SD	high-Z
DIR_1_3	X	DATA1_H, DATA2_H, DATA3_H	high-Z	DATA1_SD, DATA2_SD, DATA3_SD	high-Z
-	-	CLK_FB	high-Z	CLK_SD	high-Z

[1] H = HIGH; L = LOW and X = do not care.

## 6. Limiting values

**Table 5. Limiting values**

In accordance with the Absolute Maximum Rating System (IEC 60134).  
Voltages are referenced to GND (ground = 0 V).

Symbol	Parameter	Conditions	Min	Max	Unit
$V_{CC}$	supply voltage		-0.5	+3.5	V
$V_{BAT}$	battery supply voltage	4 ms transient	-0.5	+5.5	V
		operating	-0.5	+5.0	V
$V_I$	input voltage	at I/O pins			
		4 ms transient	-0.5	+5.5	V
		operating	-0.5	+5.0	V
$P_{tot}$	total power dissipation	$T_{amb} = -30\text{ °C to }+70\text{ °C}$	-	550	mW
$T_{stg}$	storage temperature		-55	+150	°C
$T_{amb}$	ambient temperature		-30	+85	°C
$V_{ESD}$	electrostatic discharge voltage	IEC 61000-4-2, level 4	[1]		
		contact	-	±8	kV
		air discharge	-	±15	kV
		IEC 61340-3-1, human body model	[2]	-	±2

[1] Pin  $V_{BAT}$  and all memory card-side pins to ground.

[2] All other pins to ground.

## 7. Recommended operating conditions

**Table 6. Operating conditions**

Symbol	Parameter	Conditions	Min	Max	Unit
$V_{CC}$	supply voltage		1.62	2.1	V
$V_{BAT}$	battery supply voltage		2.7[1]	5.0	V
$V_I$	input voltage	host side	0	2.1	V
		memory card side; $V_{BAT} \geq 3.2\text{ V}$	0	2.9	V
$V_O$	output voltage	active mode; pin ENABLE = HIGH			
		host side	0	$V_{CC}$	V
		memory card side	0	$V_{O(reg)}$	V
$\Delta t/\Delta V$	time difference over voltage change	host side; $V_{CC} = 0.2\text{ V to }0.7\text{ V}$	-	2	ns/V
		memory card side; $V_{O(reg)} = 0.2\text{ V to }0.7\text{ V}$	-	2	ns/V

[1] The device is still fully functional, but the voltage on pin VSD might drop below the recommended memory card supply voltage.

## 8. Static characteristics

**Table 7. Static characteristics**

At recommended operating conditions;  $T_{amb} = -30\text{ °C}$  to  $+85\text{ °C}$ ; voltages are referenced to GND (ground = 0 V); unless otherwise specified.

Symbol	Parameter	Conditions	Min	Typ <sup>[1]</sup>	Max	Unit
<b>Voltage regulator output: pin VSD</b>						
$V_{O(\text{reg})}$	regulator output voltage	$C_L = 1\ \mu\text{F}$				
		$I_{O(\text{reg})} = 0\ \text{A}$	-	2.9	2.987	V
		$I_{O(\text{reg})} = 200\ \text{mA}; V_{\text{BAT}} \geq 2.9\ \text{V}$	2.75	-	-	V
$\Delta V_{\text{do}(\text{reg})}$	regulator dropout voltage variation	$I_{O(\text{reg})} = 200\ \text{mA}$	-	-	150	mV
$I_{O(\text{reg})}$	regulator output current		-	200	-	mA
$I_{O(\text{sc})}$	short-circuit output current		-	-	500	mA
$I_{q(\text{reg})}$	regulator quiescent current	pin ENABLE = HIGH (active mode)	-	-	200	$\mu\text{A}$
		pin ENABLE = LOW (not active mode)	-	-	2	$\mu\text{A}$
$C_{\text{ext}}$	external capacitance	recommended capacitor at pin VSD	-	1.0	-	$\mu\text{F}$
<b>Control and data inputs</b>						
Host side: pins ENABLE, DIR_0, DIR_1_3, DIR_CMD, CLK_IN and DATA0_H to DATA3_H						
$V_{\text{IH}}$	HIGH-level input voltage		$0.65 \times V_{\text{CC}}$	-	-	V
$V_{\text{IL}}$	LOW-level input voltage		-	-	0.3	V
$C_{\text{ch}}$	channel capacitance	$V_I = 0\ \text{V}; f_i = 1\ \text{MHz}$	[2]	-	20	pF
Memory card side: pins CMD_SD and DATA0_SD to DATA3_SD						
$V_{\text{IH}}$	HIGH-level input voltage		$0.65 \times V_{O(\text{reg})}$	-	-	V
$V_{\text{IL}}$	LOW-level input voltage		-	-	0.3	V
$C_{\text{ch}}$	channel capacitance	$V_I = 0\ \text{V}; f_i = 1\ \text{MHz}$	[2]	-	20	pF
<b>Control and data outputs</b>						
Host side: pins CLK_FB, CMD_H and DATA0_H to DATA3_H						
$V_{\text{OH}}$	HIGH-level output voltage	$I_O = -3\ \text{mA}; V_I = V_{\text{IH}}$	$V_{\text{CC}} - 0.45$	-	-	V
$V_{\text{OL}}$	LOW-level output voltage	$I_O = 3\ \text{mA}; V_I = V_{\text{IL}}$	-	-	0.45	V
Memory card side: pins CLK_SD, CMD_SD and DATA0_SD to DATA3_SD, CD and WP						
$V_{\text{OH}}$	HIGH-level output voltage	$I_O = -6\ \text{mA}; V_I = V_{\text{IH}}$	$V_{O(\text{reg})} - 0.45$	-	-	V
$V_{\text{OL}}$	LOW-level output voltage	$I_O = 6\ \text{mA}; V_I = V_{\text{IL}}$	-	-	0.45	V
$I_{\text{LRzd}}$	Zener diode reverse leakage current	$V_I = 3\ \text{V}$	-	-	100	nA
$R_s$	series resistance	R1 to R6; tolerance $\pm 20\%$	32	40	48	$\Omega$
$R_{\text{pd}}$	pull-down resistance	R7; tolerance $\pm 30\%$	329	470	611	k $\Omega$
$R_{\text{pu}}$	pull-up resistance	R10; tolerance $\pm 30\%$	10.5	15	19.5	k $\Omega$
		R11 to R13; tolerance $\pm 30\%$	49	70	91	k $\Omega$
		R14 and R15; tolerance $\pm 30\%$	70	100	130	k $\Omega$

[1] Typical values are measured at  $T_{amb} = 25\text{ °C}$ .

[2] EMI filter line capacitance per data channel from I/O pin to driver;  $C_{\text{ch}}$  is guaranteed by design.

9. Dynamic characteristics

**Table 8. Voltage regulator**  
*T<sub>amb</sub> = 25 °C; unless otherwise specified.*

Symbol	Parameter	Conditions	Min	Typ	Max	Unit	
<b>Voltage regulator output: pin VSD</b>							
PSRR	power supply rejection ratio	V <sub>BAT</sub> = 3.0 V; V <sub>ripple(p-p)</sub> = 223.6 mV (0 dBm); R <sub>source</sub> = 50 Ω	f <sub>ripple</sub> = 1 kHz	40	-	-	dB
			f <sub>ripple</sub> = 10 kHz	30	-	-	dB
t <sub>startup(reg)</sub>	regulator start-up time	V <sub>CC</sub> = 1.8 V; V <sub>BAT</sub> = 3.0 V; I <sub>O(reg)</sub> = 200 mA; C <sub>L</sub> = 1 μF; see <a href="#">Figure 3</a>	-	-	200	μs	

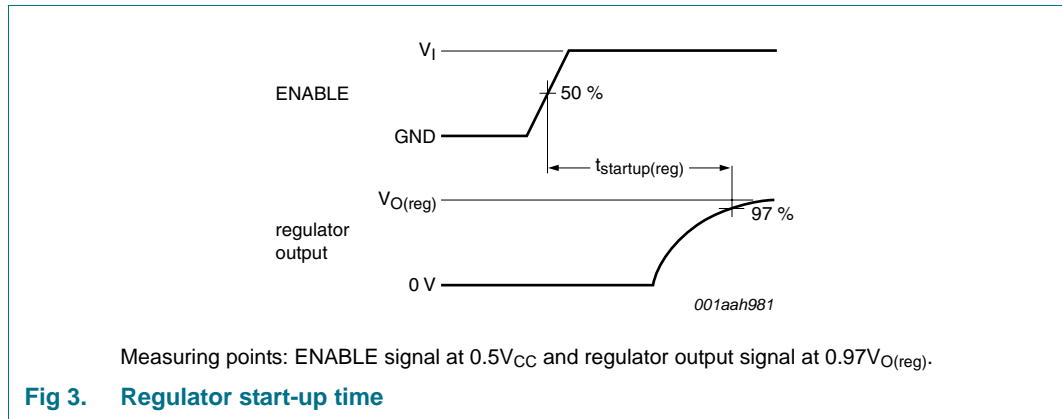

**Table 9. Frequency response of integrated EMI filters**  
*T<sub>amb</sub> = 25 °C; unless otherwise specified.*

Symbol	Parameter	Conditions	Min	Typ	Max	Unit	
<b>Clock, command and data channels<sup>[1]</sup></b>							
α <sub>il</sub>	insertion loss	R <sub>source</sub> = 50 Ω; C <sub>L</sub> = 10 pF; R <sub>L</sub> = 50 Ω	f <sub>i</sub> = 401 MHz to 800 MHz	9	-	-	dB
			f <sub>i</sub> = 801 MHz to 1.4 GHz	-	17	-	dB
			f <sub>i</sub> = 1.4 GHz to 6.0 GHz	-	32	-	dB

[1] Guaranteed by design.

**Table 10. Output rise and fall times**

$V_{BAT} = 3.5\text{ V}$ ;  $V_{O(reg)} = 2.9\text{ V}$ ; unless otherwise specified; transition time is the same as output rise time and output fall time; see [Figure 4](#) for timing diagram and [Figure 5](#) for test circuit.

Symbol	Parameter	Conditions	Min	Typ	Max	Unit	
<b>Memory card-side outputs: pins CLK_SD, CMD_SD and DATA0_SD to DATA3_SD</b>							
Reference points at 70 % and 20 %							
$t_t$	transition time	$C_L = 20\text{ pF}$ ; $R_L = 100\text{ k}\Omega$					
		$T_{amb} = +25\text{ }^\circ\text{C}$ ; $V_{CC} = 1.8\text{ V}$	-	1.5	2.5	ns	
		$T_{amb} = -30\text{ }^\circ\text{C}$ ; $V_{CC} = 1.9\text{ V}$	-	1.5	2.5	ns	
		$T_{amb} = +70\text{ }^\circ\text{C}$ ; $V_{CC} = 1.62\text{ V}$	-	1.8	2.8	ns	
		$C_L = 40\text{ pF}$ ; $R_L = 100\text{ k}\Omega$					
		$T_{amb} = +25\text{ }^\circ\text{C}$ ; $V_{CC} = 1.8\text{ V}$	-	2.7	3.6	ns	
		$T_{amb} = -30\text{ }^\circ\text{C}$ ; $V_{CC} = 1.9\text{ V}$	-	2.7	3.6	ns	
		$T_{amb} = +70\text{ }^\circ\text{C}$ ; $V_{CC} = 1.62\text{ V}$	-	2.9	3.8	ns	
		Reference points at 90 % and 10 %					
$t_t$	transition time	$C_L = 20\text{ pF}$ ; $R_L = 100\text{ k}\Omega$					
		$T_{amb} = +25\text{ }^\circ\text{C}$ ; $V_{CC} = 1.8\text{ V}$	-	3.0	4.2	ns	
		$T_{amb} = -30\text{ }^\circ\text{C}$ ; $V_{CC} = 1.9\text{ V}$	-	2.9	4.1	ns	
		$T_{amb} = +70\text{ }^\circ\text{C}$ ; $V_{CC} = 1.62\text{ V}$	-	3.7	4.9	ns	
		<b>Host-side outputs: pins CLK_FB, CMD_H and DATA0_H to DATA3_H</b>					
Reference points at 70 % and 20 %							
$t_t$	transition time	$C_L = 5\text{ pF}$ ; $R_L = 100\text{ k}\Omega$					
		$T_{amb} = +25\text{ }^\circ\text{C}$ ; $V_{CC} = 1.8\text{ V}$	-	1.5	2.4	ns	
		$T_{amb} = -30\text{ }^\circ\text{C}$ ; $V_{CC} = 1.9\text{ V}$	-	1.3	2.3	ns	
		$T_{amb} = +70\text{ }^\circ\text{C}$ ; $V_{CC} = 1.62\text{ V}$	-	1.6	2.5	ns	
		$C_L = 20\text{ pF}$ ; $R_L = 100\text{ k}\Omega$					
		$T_{amb} = +25\text{ }^\circ\text{C}$ ; $V_{CC} = 1.8\text{ V}$	-	1.7	2.9	ns	
		$T_{amb} = -30\text{ }^\circ\text{C}$ ; $V_{CC} = 1.9\text{ V}$	-	1.4	2.5	ns	
		$T_{amb} = +70\text{ }^\circ\text{C}$ ; $V_{CC} = 1.62\text{ V}$	-	1.8	3.0	ns	
		Reference points at 90 % and 10 %					
$t_t$	transition time	$C_L = 5\text{ pF}$ ; $R_L = 100\text{ k}\Omega$					
		$T_{amb} = +25\text{ }^\circ\text{C}$ ; $V_{CC} = 1.8\text{ V}$	-	2.4	3.1	ns	
		$T_{amb} = -30\text{ }^\circ\text{C}$ ; $V_{CC} = 1.9\text{ V}$	-	2.3	3.0	ns	
		$T_{amb} = +70\text{ }^\circ\text{C}$ ; $V_{CC} = 1.62\text{ V}$	-	2.5	3.2	ns	

**Table 11. Propagation delay of time domain response driver part**

$V_{BAT} = 3.5\text{ V}$ ;  $V_{O(reg)} = 2.9\text{ V}$ ;  $R_{source} = 50\ \Omega$ ; propagation delay measurements include PCB delays and connectors; see [Figure 4](#) for timing diagram and [Figure 5](#) for test circuit.

Symbol	Parameter	Conditions	Min	Typ	Max	Unit		
<b>Host-side inputs to memory card-side outputs</b>								
$t_{PD}$	propagation delay	nominal case; $T_{amb} = +27\text{ }^\circ\text{C}$ ; $V_{CC} = 1.8\text{ V}$	[1]					
		$C_L = 20\text{ pF}$	6.2	7.0	7.8	ns		
		$C_L = 40\text{ pF}$	7.3	8.2	9.1	ns		
		best case; $T_{amb} = -30\text{ }^\circ\text{C}$ ; $V_{CC} = 1.9\text{ V}$						
		$C_L = 20\text{ pF}$	5.7	6.5	7.3	ns		
		$C_L = 40\text{ pF}$	6.5	7.5	8.5	ns		
		worst case; $T_{amb} = +70\text{ }^\circ\text{C}$ ; $V_{CC} = 1.62\text{ V}$						
		$C_L = 20\text{ pF}$	6.7	7.8	8.9	ns		
		$C_L = 40\text{ pF}$	7.5	8.8	10.1	ns		
		<b>Memory card-side inputs to host-side outputs</b>						
		$t_{PD}$	propagation delay	nominal case; $T_{amb} = +27\text{ }^\circ\text{C}$ ; $V_{CC} = 1.8\text{ V}$	[1]			
				$C_L = 5\text{ pF}$	4.2	6.0	7.8	ns
$C_L = 20\text{ pF}$	6.3			7.2	8.1	ns		
best case; $T_{amb} = -30\text{ }^\circ\text{C}$ ; $V_{CC} = 1.9\text{ V}$								
$C_L = 5\text{ pF}$	4			5.9	6.9	ns		
$C_L = 20\text{ pF}$	5.1			6.7	8.5	ns		
worst case; $T_{amb} = +70\text{ }^\circ\text{C}$ ; $V_{CC} = 1.62\text{ V}$								
$C_L = 5\text{ pF}$	5.4			6.5	7.7	ns		
$C_L = 20\text{ pF}$	6.7			8.0	9.2	ns		
<b>Host-side pins CLK_IN to CLK_FB</b>								
$t_{PD}$	propagation delay			nominal case; $T_{amb} = +27\text{ }^\circ\text{C}$ ; $V_{CC} = 1.8\text{ V}$	[1]			
				$C_L = 5\text{ pF}$	7.6	9.2	10.7	ns
		$C_L = 20\text{ pF}$	8.2	9.9	11.6	ns		
		best case; $T_{amb} = -30\text{ }^\circ\text{C}$ ; $V_{CC} = 1.9\text{ V}$						
		$C_L = 5\text{ pF}$	6.7	8.1	9.5	ns		
		$C_L = 20\text{ pF}$	7.6	8.8	10.5	ns		
		worst case; $T_{amb} = +70\text{ }^\circ\text{C}$ ; $V_{CC} = 1.62\text{ V}$						
		$C_L = 5\text{ pF}$	8.5	10.7	12.9	ns		
		$C_L = 20\text{ pF}$	9.1	11.4	13.9	ns		

[1]  $t_{PD}$  is the same as HIGH-to-LOW propagation delay ( $t_{PHL}$ ) and LOW-to-HIGH propagation delay ( $t_{PLH}$ ).

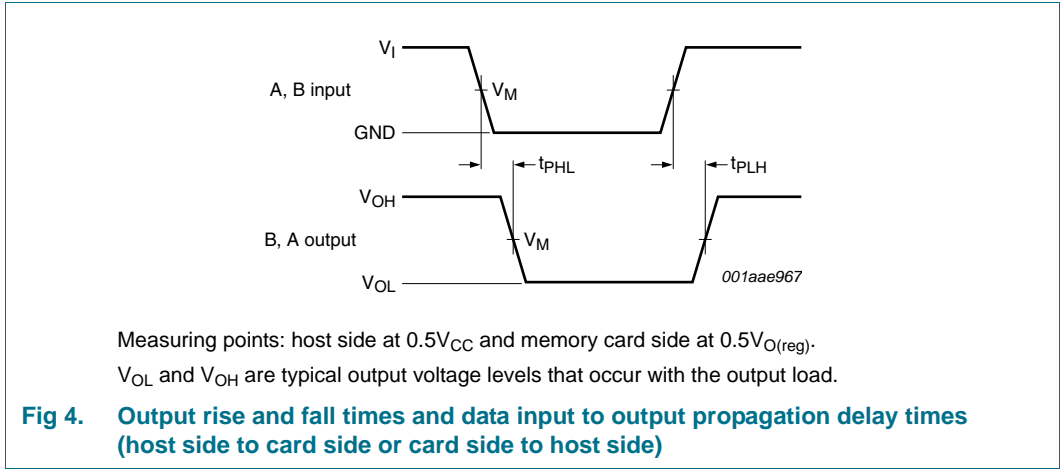

**Table 12. Power dissipation per channel**

$V_{CC} = 1.8\text{ V}$ ;  $V_{BAT} = 4\text{ V}$ ; all values are typical; memory card side  $C_L = 20\text{ pF}$  and host side  $C_L = 5\text{ pF}$ .

Frequency (MHz)	$I_{BAT}$ (mA)	$I_{CC}$ (mA)	P (mW) <sup>[1]</sup>
<b>Host-side input to memory card-side output</b>			
Data channel			
1.0	0.79	0.002	3.16
10.0	3.30	0.020	13.3
20.0	5.79	0.037	23.2
50.0	12.3	0.090	49.4
Clock channel			
1.0	0.44	0.05	1.85
10.0	3.1	0.59	13.5
20.0	5.4	0.97	23.4
50.0	12.2	2.36	53.1
<b>Memory card-side input to host-side output</b>			
Data channel			
1.0	0.18	0.1	0.9
10.0	0.42	0.96	3.41
20.0	0.66	1.91	6.1
50.0	1.4	4.5	13.7

[1] Power consumption is largely dependent on capacitive load connected to a driver output:  
 $P = V_{CC} \times I_{CC} + V_{BAT} \times I_{BAT}$ .

10. Test information

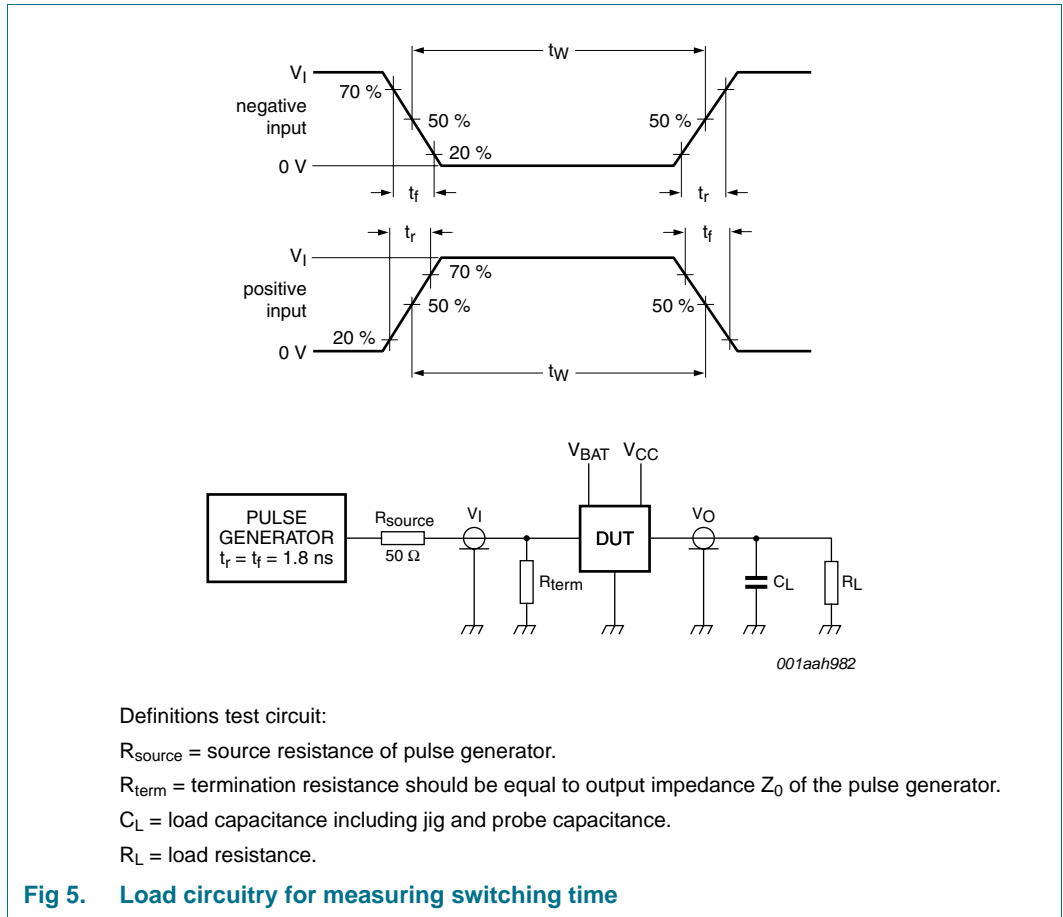

Fig 5. Load circuitry for measuring switching time

11. Marking

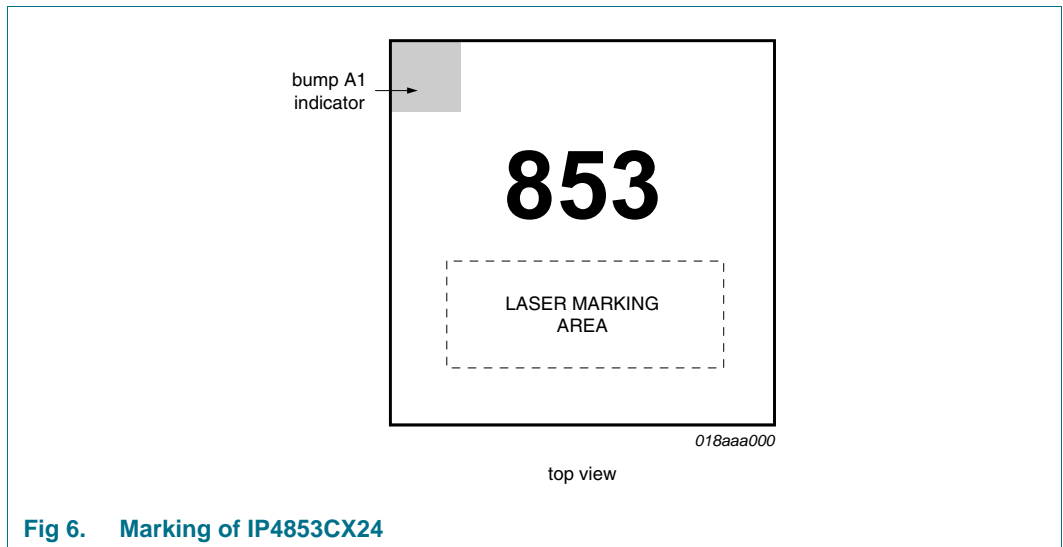

Fig 6. Marking of IP4853CX24

12. Package outline

WLCSP24: wafer level chip-size package; 24 bumps (5 x 5 - B2)

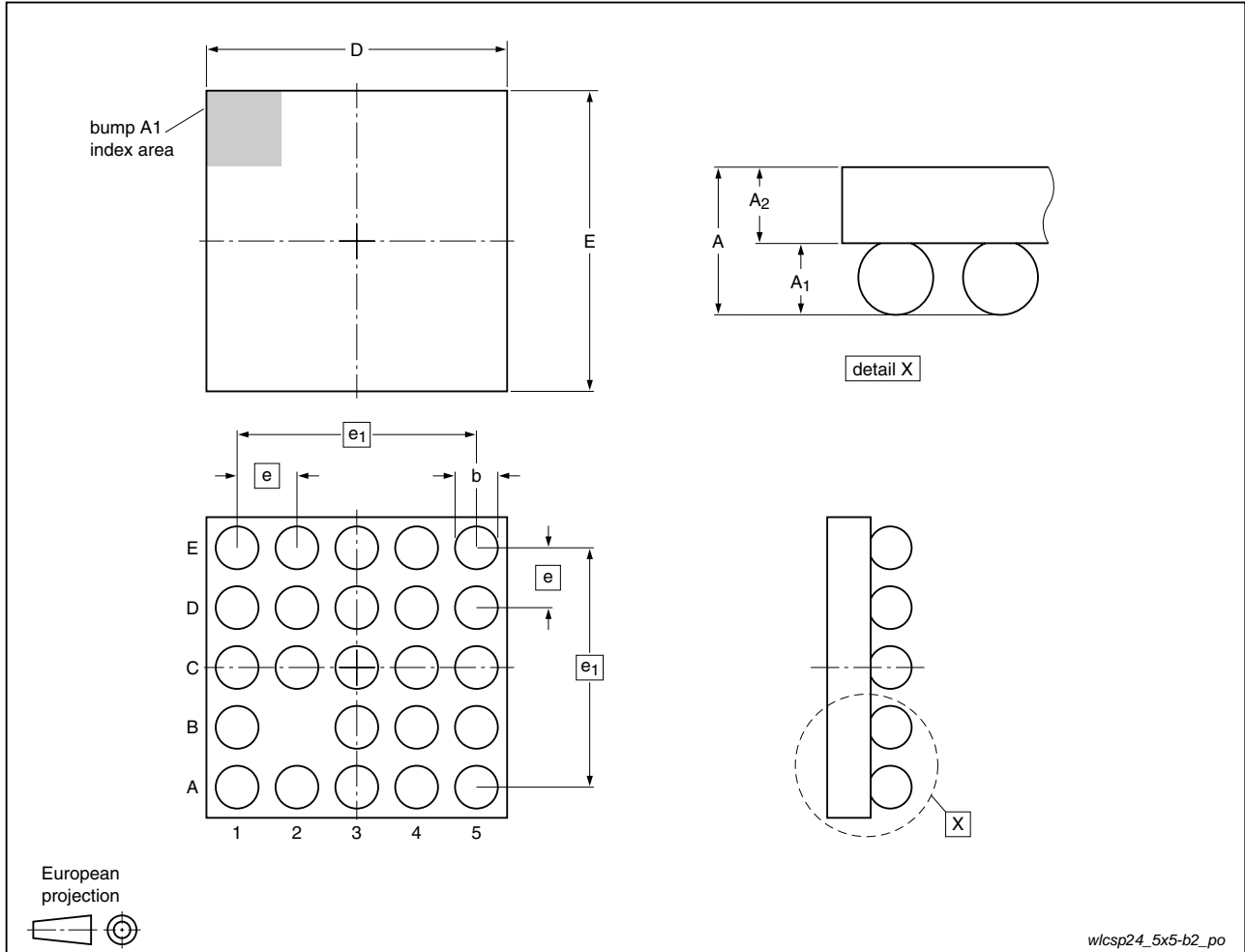

Fig 7. Package outline IP4853CX24 (WLCSP24)

Table 13. Package outline dimensions

Symbol	Min	Typ	Max	Unit
A	0.57	0.61	0.65	mm
A <sub>1</sub>	0.18	0.20	0.22	mm
A <sub>2</sub>	0.39	0.41	0.43	mm
b	0.21	0.26	0.31	mm
D	1.94	1.99	2.04	mm
E	1.94	1.99	2.04	mm
e	-	0.40	-	mm
e <sub>1</sub>	-	1.6	-	mm

13. Packing information

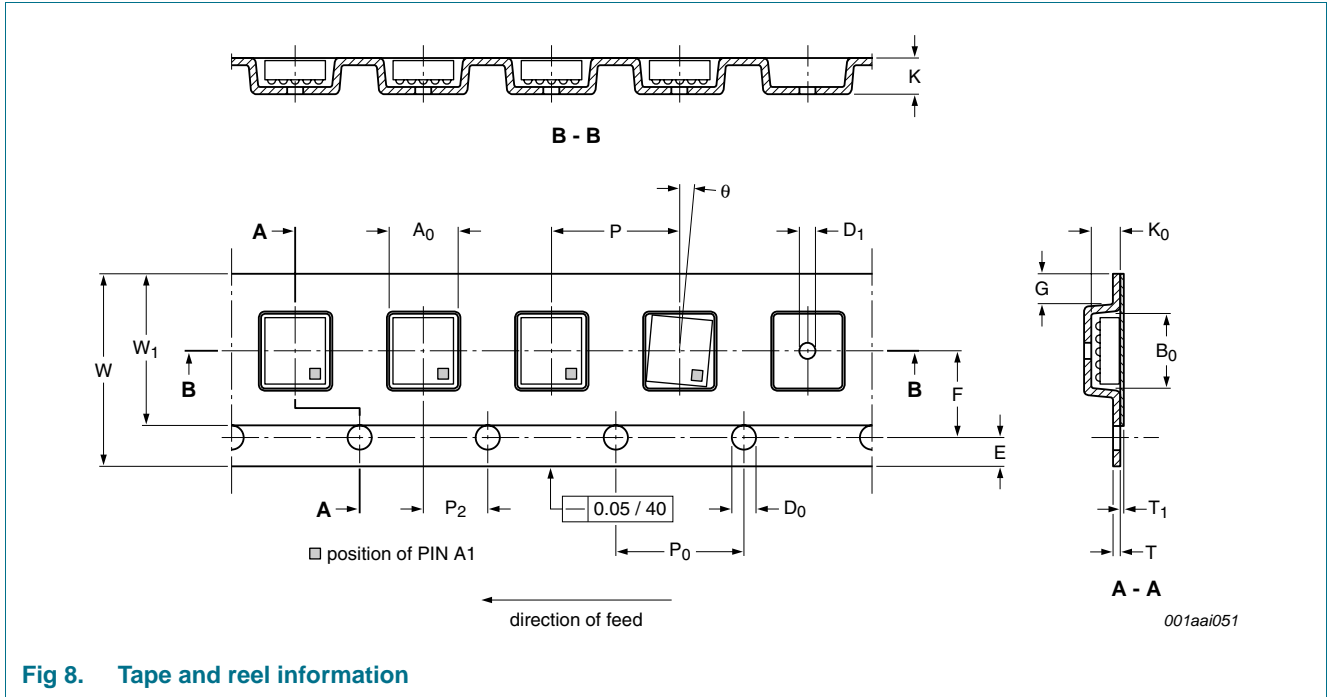

Fig 8. Tape and reel information

Table 14. Tape dimensions

Description	Item	Symbol	Specification (mm)	
			Dimension	Tolerance
Overall dimensions	tape width	W	8.00	±0.1
	thickness	K	1.20	max.
	distance	G	0.75	min.
Sprocket holes <sup>[1]</sup>	diameter	D <sub>0</sub>	1.50	+0.1
	distance	E	1.75	±0.1
	pitch	P <sub>0</sub>	4.00	±0.1
Distance between center lines	length direction	P <sub>2</sub>	2.00	±0.05
	width direction	F	3.50	±0.05
Compartments	length	A <sub>0</sub>	2.20	±0.05
	width	B <sub>0</sub>	2.20	±0.05
	depth	K <sub>0</sub>	0.80	±0.05
	hole diameter	D <sub>1</sub>	0.50	+0.1
	pitch	P	4.00	±0.1

Table 14. Tape dimensions ...continued

Description	Item	Symbol	Specification (mm)	
			Dimension	Tolerance
Device	rotation	$\theta$	20°	max.
Carrier tape antistatic <sup>[2]</sup>	film thickness	T	0.25	±0.07
Cover tape <sup>[3]</sup>	width	$W_1$	5.75	max.
	film thickness	$T_1$	0.1	max.
Bending radius	in winding direction	R	30	min.

[1] Cumulated pitch error: ±0.2 mm per 10 pitches.

[2] Carbon loaded polystyrene 100 % recyclable.

[3] The cover tape shall not overlap the sprocket holes.

## 14. Design and assembly recommendations

### 14.1 PCB design guidelines

To achieve optimum performance it is recommended to use a Non-Solder Mask Design (NSMD) Printed-Circuit Board (PCB) design, also known as a copper-defined design, incorporating laser-drilled micro-vias connecting the ground pads to a buried ground-plane layer. This results in the lowest possible ground inductance and provides the best high frequency and ESD performance. Refer to [Table 15](#) for the recommended PCB design parameters.

Table 15. Recommended PCB design parameters

PCB pad size	225 $\mu\text{m}$ diameter
Micro-via diameter	100 $\mu\text{m}$
Solder mask opening	335 $\mu\text{m}$ diameter
Copper thickness	20 $\mu\text{m}$ to 40 $\mu\text{m}$
Copper finish	OSP
PCB material	FR4

### 14.2 PCB assembly guidelines for Pb-free soldering

Table 16. Assemble recommendations

Solder screen aperture size	255 $\mu\text{m}$ diameter
Solder screen thickness	100 $\mu\text{m}$ (0.004")
Solder paste: Pb-free	SnAg <sup>[1]</sup> Cu <sup>[2]</sup>
Solder/flux ratio	50 : 50
Solder reflow profile	see <a href="#">Figure 9</a>

[1] 3 to 4.

[2] 0.5 to 0.9.

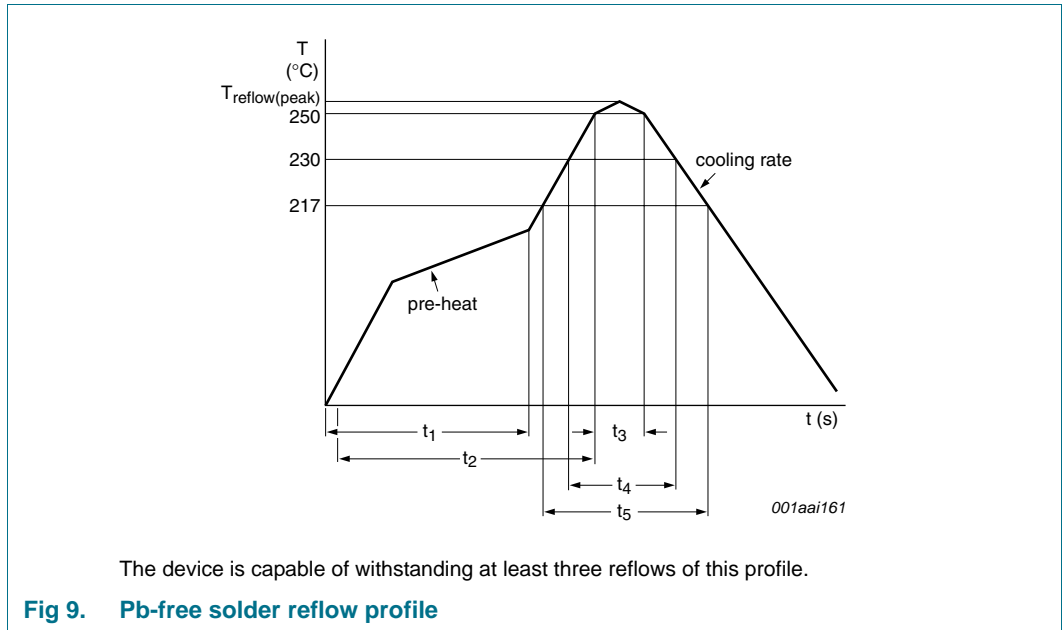

**Table 17. Characteristics**

Symbol	Parameter	Conditions	Min	Typ	Max	Unit
$T_{\text{reflow(peak)}}$	peak reflow temperature		230	-	260	°C
$t_1$	time 1	soak time	60	-	180	s
$t_2$	time 2	time from $T = 25\text{ °C}$ to $T_{\text{reflow(peak)}}$	240	-	300	s
$t_3$	time 3	time during $T \geq 250\text{ °C}$	-	-	30	s
$t_4$	time 4	time during $T \geq 230\text{ °C}$	10	-	50	s
$t_5$	time 5	time during $T > 217\text{ °C}$	30	-	150	s
$dT/dt$	rate of change of temperature	cooling rate	-	-	-6	°C/s
		pre-heat	2.5	-	4.0	°C/s

## 15. Abbreviations

Table 18. Abbreviations

Acronym	Description
DUT	Device Under Test
EMI	ElectroMagnetic Interference
ESD	ElectroStatic Discharge
FR4	Flame Retard 4
MMC	Multi Media Card
NSMD	Non-Solder Mask Design
OSP	Organic Solderability Preservation
PCB	Printed-Circuit Board
PSU	Power Supply Unit
RoHS	Restriction of Hazardous Substances
SD	Secure Digital
WLCSP	Wafer Level Chip-Size Package

## 16. Revision history

**Table 19. Revision history**

Document ID	Release date	Data sheet status	Change notice	Supersedes
IP4853CX24 v.3	20100930	Product data sheet	-	IP4853CX24_2
Modifications:		<ul style="list-style-type: none"><li>• <a href="#">Section 3 “Ordering information”</a>: updated.</li><li>• <a href="#">Figure 6 “Marking of IP4853CX24”</a>: updated.</li><li>• <a href="#">Section 12 “Package outline”</a>: updated.</li><li>• <a href="#">Figure 8 “Tape and reel information”</a>: updated.</li><li>• <a href="#">Table 17</a>: T<sub>reflow(peak)</sub> updated.</li><li>• <a href="#">Section 17 “Legal information”</a>: updated.</li></ul>		
IP4853CX24_2	20090615	Product data sheet	-	IP4853CX24_1
IP4853CX24_1	20080722	Product data sheet	-	-

## 17. Legal information

### 17.1 Data sheet status

Document status <sup>[1][2]</sup>	Product status <sup>[3]</sup>	Definition
Objective [short] data sheet	Development	This document contains data from the objective specification for product development.
Preliminary [short] data sheet	Qualification	This document contains data from the preliminary specification.
Product [short] data sheet	Production	This document contains the product specification.

[1] Please consult the most recently issued document before initiating or completing a design.

[2] The term 'short data sheet' is explained in section "Definitions".

[3] The product status of device(s) described in this document may have changed since this document was published and may differ in case of multiple devices. The latest product status information is available on the Internet at URL <http://www.nxp.com>.

### 17.2 Definitions

**Draft** — The document is a draft version only. The content is still under internal review and subject to formal approval, which may result in modifications or additions. NXP Semiconductors does not give any representations or warranties as to the accuracy or completeness of information included herein and shall have no liability for the consequences of use of such information.

**Short data sheet** — A short data sheet is an extract from a full data sheet with the same product type number(s) and title. A short data sheet is intended for quick reference only and should not be relied upon to contain detailed and full information. For detailed and full information see the relevant full data sheet, which is available on request via the local NXP Semiconductors sales office. In case of any inconsistency or conflict with the short data sheet, the full data sheet shall prevail.

**Product specification** — The information and data provided in a Product data sheet shall define the specification of the product as agreed between NXP Semiconductors and its customer, unless NXP Semiconductors and customer have explicitly agreed otherwise in writing. In no event however, shall an agreement be valid in which the NXP Semiconductors product is deemed to offer functions and qualities beyond those described in the Product data sheet.

### 17.3 Disclaimers

**Limited warranty and liability** — Information in this document is believed to be accurate and reliable. However, NXP Semiconductors does not give any representations or warranties, expressed or implied, as to the accuracy or completeness of such information and shall have no liability for the consequences of use of such information.

In no event shall NXP Semiconductors be liable for any indirect, incidental, punitive, special or consequential damages (including - without limitation - lost profits, lost savings, business interruption, costs related to the removal or replacement of any products or rework charges) whether or not such damages are based on tort (including negligence), warranty, breach of contract or any other legal theory.

Notwithstanding any damages that customer might incur for any reason whatsoever, NXP Semiconductors' aggregate and cumulative liability towards customer for the products described herein shall be limited in accordance with the *Terms and conditions of commercial sale* of NXP Semiconductors.

**Right to make changes** — NXP Semiconductors reserves the right to make changes to information published in this document, including without limitation specifications and product descriptions, at any time and without notice. This document supersedes and replaces all information supplied prior to the publication hereof.

**Suitability for use** — NXP Semiconductors products are not designed, authorized or warranted to be suitable for use in life support, life-critical or safety-critical systems or equipment, nor in applications where failure or

malfunction of an NXP Semiconductors product can reasonably be expected to result in personal injury, death or severe property or environmental damage. NXP Semiconductors accepts no liability for inclusion and/or use of NXP Semiconductors products in such equipment or applications and therefore such inclusion and/or use is at the customer's own risk.

**Applications** — Applications that are described herein for any of these products are for illustrative purposes only. NXP Semiconductors makes no representation or warranty that such applications will be suitable for the specified use without further testing or modification.

Customers are responsible for the design and operation of their applications and products using NXP Semiconductors products, and NXP Semiconductors accepts no liability for any assistance with applications or customer product design. It is customer's sole responsibility to determine whether the NXP Semiconductors product is suitable and fit for the customer's applications and products planned, as well as for the planned application and use of customer's third party customer(s). Customers should provide appropriate design and operating safeguards to minimize the risks associated with their applications and products.

NXP Semiconductors does not accept any liability related to any default, damage, costs or problem which is based on any weakness or default in the customer's applications or products, or the application or use by customer's third party customer(s). Customer is responsible for doing all necessary testing for the customer's applications and products using NXP Semiconductors products in order to avoid a default of the applications and the products or of the application or use by customer's third party customer(s). NXP does not accept any liability in this respect.

**Limiting values** — Stress above one or more limiting values (as defined in the Absolute Maximum Ratings System of IEC 60134) will cause permanent damage to the device. Limiting values are stress ratings only and (proper) operation of the device at these or any other conditions above those given in the Recommended operating conditions section (if present) or the Characteristics sections of this document is not warranted. Constant or repeated exposure to limiting values will permanently and irreversibly affect the quality and reliability of the device.

**Terms and conditions of commercial sale** — NXP Semiconductors products are sold subject to the general terms and conditions of commercial sale, as published at <http://www.nxp.com/profile/terms>, unless otherwise agreed in a valid written individual agreement. In case an individual agreement is concluded only the terms and conditions of the respective agreement shall apply. NXP Semiconductors hereby expressly objects to applying the customer's general terms and conditions with regard to the purchase of NXP Semiconductors products by customer.

**No offer to sell or license** — Nothing in this document may be interpreted or construed as an offer to sell products that is open for acceptance or the grant, conveyance or implication of any license under any copyrights, patents or other industrial or intellectual property rights.

**Export control** — This document as well as the item(s) described herein may be subject to export control regulations. Export might require a prior authorization from national authorities.

**Non-automotive qualified products** — Unless this data sheet expressly states that this specific NXP Semiconductors product is automotive qualified, the product is not suitable for automotive use. It is neither qualified nor tested in accordance with automotive testing or application requirements. NXP Semiconductors accepts no liability for inclusion and/or use of non-automotive qualified products in automotive equipment or applications.

In the event that customer uses the product for design-in and use in automotive applications to automotive specifications and standards, customer (a) shall use the product without NXP Semiconductors' warranty of the product for such automotive applications, use and specifications, and (b) whenever customer uses the product for automotive applications beyond

NXP Semiconductors' specifications such use shall be solely at customer's own risk, and (c) customer fully indemnifies NXP Semiconductors for any liability, damages or failed product claims resulting from customer design and use of the product for automotive applications beyond NXP Semiconductors' standard warranty and NXP Semiconductors' product specifications.

## 17.4 Trademarks

Notice: All referenced brands, product names, service names and trademarks are the property of their respective owners.

## 18. Contact information

For more information, please visit: <http://www.nxp.com>

For sales office addresses, please send an email to: [salesaddresses@nxp.com](mailto:salesaddresses@nxp.com)

## 19. Contents

<b>1</b>	<b>Product profile</b> . . . . .	<b>1</b>
1.1	General description . . . . .	1
1.2	Features and benefits . . . . .	1
1.3	Applications . . . . .	1
<b>2</b>	<b>Pinning information</b> . . . . .	<b>2</b>
2.1	Pinning . . . . .	2
2.2	Pin description . . . . .	2
<b>3</b>	<b>Ordering information</b> . . . . .	<b>3</b>
<b>4</b>	<b>Block diagram</b> . . . . .	<b>4</b>
<b>5</b>	<b>Functional description</b> . . . . .	<b>5</b>
5.1	Logic control signals . . . . .	5
<b>6</b>	<b>Limiting values</b> . . . . .	<b>6</b>
<b>7</b>	<b>Recommended operating conditions</b> . . . . .	<b>6</b>
<b>8</b>	<b>Static characteristics</b> . . . . .	<b>7</b>
<b>9</b>	<b>Dynamic characteristics</b> . . . . .	<b>8</b>
<b>10</b>	<b>Test information</b> . . . . .	<b>12</b>
<b>11</b>	<b>Marking</b> . . . . .	<b>12</b>
<b>12</b>	<b>Package outline</b> . . . . .	<b>13</b>
<b>13</b>	<b>Packing information</b> . . . . .	<b>14</b>
<b>14</b>	<b>Design and assembly recommendations</b> . . . . .	<b>15</b>
14.1	PCB design guidelines . . . . .	15
14.2	PCB assembly guidelines for Pb-free soldering . . . . .	15
<b>15</b>	<b>Abbreviations</b> . . . . .	<b>17</b>
<b>16</b>	<b>Revision history</b> . . . . .	<b>18</b>
<b>17</b>	<b>Legal information</b> . . . . .	<b>19</b>
17.1	Data sheet status . . . . .	19
17.2	Definitions . . . . .	19
17.3	Disclaimers . . . . .	19
17.4	Trademarks . . . . .	20
<b>18</b>	<b>Contact information</b> . . . . .	<b>20</b>
<b>19</b>	<b>Contents</b> . . . . .	<b>21</b>

Please be aware that important notices concerning this document and the product(s) described herein, have been included in section 'Legal information'.

© NXP B.V. 2010.

All rights reserved.

For more information, please visit: <http://www.nxp.com>



For sales office addresses, please send an email to: [salesaddresses@nxp.com](mailto:salesaddresses@nxp.com)

Date of release: 30 September 2010

Document identifier: IP4853CX24

## Looking for pricing, stock, or lifecycle information?

Click below to explore more details on WIN SOURCE:

-  [View IP4853CX24/P,135 on WIN SOURCE](#)
-  [NXP / Nexperia Information](#)

## Optimize Your Supply Chain with WIN SOURCE Solutions

-  Global Sourcing Solution
-  Obsolete Management
-  Cost Control Management
-  Shortage Management
-  Alternative Solution
-  Excess Inventory Management