



THE DATASHEET OF SN74LVC112ADBR



SN74LVC112A Dual Negative-Edge-Triggered J-K Flip-Flop with Clear and Preset

1 Features

- Operates from 1.65V to 3.6V
- Inputs accept voltages to 5.5V
- Max t_{pd} of 4.8ns at 3.3V
- Typical V_{OLP} (output ground bounce)
< 0.8V at $V_{CC} = 3.3V, T_A = 25^\circ C$
- Typical V_{OHV} (output V_{OH} undershoot)
> 2V at $V_{CC} = 3.3V, T_A = 25^\circ C$
- Latch-up performance exceeds 250mA per JESD 17

2 Applications

- Servers
- PCs
- Notebooks
- Network switches
- Toys
- I/O Expanders
- Electronic Points-of-Sale

3 Description

This dual negative-edge-triggered J-K flip-flop is designed for 1.65V to 3.6V V_{CC} operation.

Package Information

PART NUMBER	PACKAGE ⁽¹⁾	PACKAGE SIZE ⁽²⁾	BODY SIZE ⁽³⁾
SN74LVC112A	DB (SSOP, 16)	6.20mm × 7.8mm	6.20mm × 5.30mm
	PW (TSSOP, 16)	5.00mm × 6.4mm	5.00mm × 4.40mm
	DGV (TVSOP, 16)	3.6mm × 6.4mm	3.60mm × 4.40mm
	NS (SOP, 16)	10.2mm × 7.8mm	10.20mm × 5.30mm
	D (SOIC, 16)	9.90 mm × 6mm	9.90mm × 3.90mm

- (1) For more information, see [Section 11](#).
- (2) The package size (length × width) is a nominal value and includes pins, where applicable.
- (3) The body size (length × width) is a nominal value and does not include pins.

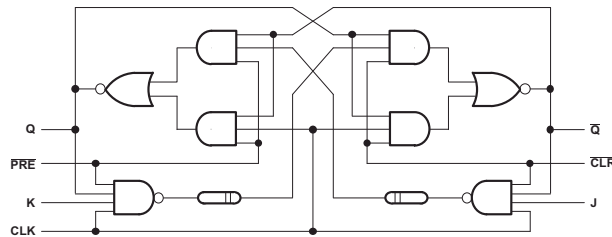

Simplified Schematic

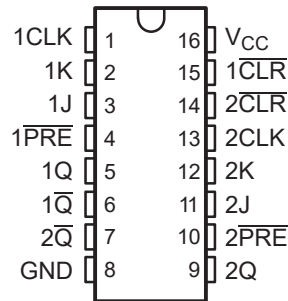

Table of Contents

1 Features	1	7.1 Overview.....	9
2 Applications	1	7.2 Functional Block Diagram.....	9
3 Description	1	7.3 Feature Description.....	9
4 Pin Configuration and Functions	3	7.4 Device Functional Modes.....	9
5 Specifications	4	8 Application and Implementation	10
5.1 Absolute Maximum Ratings.....	4	8.1 Application Information.....	10
5.2 ESD Ratings.....	4	8.2 Typical Application.....	10
5.3 Recommended Operating Conditions.....	5	8.3 Power Supply Recommendations.....	11
5.4 Thermal Information.....	5	8.4 Layout.....	11
5.5 Electrical Characteristics.....	6	9 Device and Documentation Support	12
5.6 Timing Requirements, –40°C to +85°C.....	6	9.1 Receiving Notification of Documentation Updates....	12
5.7 Timing Requirements, –40°C to +125°C.....	6	9.2 Support Resources.....	12
5.8 Switching Characteristics, –40°C to +85°C.....	7	9.3 Trademarks.....	12
5.9 Switching Characteristics, –40°C to +125°C.....	7	9.4 Electrostatic Discharge Caution.....	12
5.10 Operating Characteristics.....	7	9.5 Glossary.....	12
5.11 Typical Characteristics.....	7	10 Revision History	12
6 Parameter Measurement Information	8	11 Mechanical, Packaging, and Orderable Information	13
7 Detailed Description	9		

4 Pin Configuration and Functions

D, DB, DGV, NS, OR PW PACKAGE
(TOP VIEW)



Pin Functions

Table 4-1. Pin Functions

PIN		TYPE	DESCRIPTION
NO.	NAME		
1	1CLK	I	1 Clock
2	1K	I	1K Input
3	1J	I	1J Input
4	1 $\overline{\text{PRE}}$	I	1 Preset
5	1Q	O	1Q Output. Pull low to set 1Q high and 1 $\overline{\text{Q}}$ low upon power-up.
6	1 $\overline{\text{Q}}$	O	1 $\overline{\text{Q}}$ Output
7	2 $\overline{\text{Q}}$	O	2 $\overline{\text{Q}}$ Output
8	GND	—	Ground Pin
9	2Q	O	2Q Output
10	2 $\overline{\text{PRE}}$	I	2 Preset
11	2J	I	2J Input. Pull low to set 2Q high and 2 $\overline{\text{Q}}$ low upon power-up.
12	2K	I	2K Input
13	2CLK	I	2 Clock
14	2 $\overline{\text{CLR}}$	I	2 Clear
15	1 $\overline{\text{CLR}}$	I	1 Clear. Pull low to set 2Q low and 2 $\overline{\text{Q}}$ high upon power-up.
16	V _{CC}	—	Power Pin. Pull low to set 1Q low and 1 $\overline{\text{Q}}$ high upon power-up.

5 Specifications

5.1 Absolute Maximum Ratings

over operating free-air temperature range (unless otherwise noted)⁽¹⁾

		MIN	MAX	UNIT
V _{CC}	Supply voltage	-0.5	6.5	V
V _I	Input voltage ⁽²⁾	-0.5	6.5	V
V _O	Output voltage ^{(2) (3)}	-0.5	V _{CC} + 0.5	V
I _{IK}	Input clamp current	V _I < 0	-50	mA
I _{OK}	Output clamp current	V _O < 0	-50	mA
I _O	Continuous output current		±50	mA
	Continuous current through V _{CC} or GND		±100	mA
T _{stg}	Storage temperature		150	°C

- (1) Stresses beyond those listed under *Absolute Maximum Ratings* may cause permanent damage to the device. These are stress ratings only, and functional operation of the device at these or any other conditions beyond those indicated under *Recommended Operating Conditions* is not implied. Exposure to absolute-maximum-rated conditions for extended periods may affect device reliability.
- (2) The input and output negative-voltage ratings may be exceeded if the input and output current ratings are observed.
- (3) The value of V_{CC} is provided in the *Recommended Operating Conditions* table.

5.2 ESD Ratings

		VALUE	UNIT
V _(ESD)	Electrostatic discharge	Human body model (HBM), per ANSI/ESDA/JEDEC JS-001, all pins ⁽¹⁾	±2000
		Charged device model (CDM), per JEDEC specification JESD22-C101, all pins ⁽²⁾	±1000

- (1) JEDEC document JEP155 states that 500V HBM allows safe manufacturing with a standard ESD control process.
- (2) JEDEC document JEP157 states that 250V CDM allows safe manufacturing with a standard ESD control process.

5.3 Recommended Operating Conditions

over operating free-air temperature range (unless otherwise noted)⁽¹⁾

		MIN	MAX	UNIT	
V _{CC}	Supply voltage	Operating	1.65	3.6	V
		Data retention only	1.5		
V _{IH}	High-level input voltage	V _{CC} = 1.65 V to 1.95 V	0.65 × V _{CC}		V
		V _{CC} = 2.3 V to 2.7 V	1.7		
		V _{CC} = 2.7 V to 3.6 V	2		
V _{IL}	Low-level input voltage	V _{CC} = 1.65 V to 1.95 V	0.35 × V _{CC}		V
		V _{CC} = 2.3 V to 2.7 V	0.7		
		V _{CC} = 2.7 V to 3.6 V	0.8		
V _I	Input voltage	0	5.5	V	
V _O	Output voltage	0	V _{CC}	V	
I _{OH}	High-level output current	V _{CC} = 1.65 V	-4		mA
		V _{CC} = 2.3 V	-8		
		V _{CC} = 2.7 V	-12		
		V _{CC} = 3 V	-24		
I _{OL}	Low-level output current	V _{CC} = 1.65 V	4		mA
		V _{CC} = 2.3 V	8		
		V _{CC} = 2.7 V	12		
		V _{CC} = 3 V	24		
Δt/Δv	Input transition rise or fall rate		10	ns/V	
T _A	Operating free-air temperature	-40	125	°C	

(1) All unused inputs of the device must be held at V_{CC} or GND to ensure proper device operation. Refer to the TI application report, *Implications of Slow or Floating CMOS Inputs (SCBA004)*.

5.4 Thermal Information

THERMAL METRIC ⁽¹⁾	SN74LVC112A					UNIT	
	D (SOIC)	DB (SSOP)	DGV (TVSOP)	NS (SOP)	PW (TSSOP)		
	16 PINS	16 PINS	16 PINS	16 PINS	16 PINS		
R _{θJA}	Junction-to-ambient thermal resistance	118.1	122.5	129.0	117.5	141.8	°C/W
R _{θJC(top)}	Junction-to-case (top) thermal resistance	81.6	75.2	52.1	76	51.4	
R _{θJB}	Junction-to-board thermal resistance	80	85.5	62.0	84.2	64.4	
ψ _{JT}	Junction-to-top characterization parameter	36.3	30.5	6.5	34.2	6.7	
ψ _{JB}	Junction-to-board characterization parameter	79.2	84.1	61.3	83.1	63.8	
R _{θJC(bot)}	Junction-to-case (bottom) thermal resistance	N/A	N/A	N/A	N/A	N/A	

(1) For more information about traditional and new thermal metrics, see the IC Package Thermal Metrics application report, [SPRA953](#)

5.5 Electrical Characteristics

over recommended operating free-air temperature range (unless otherwise noted)

PARAMETER	TEST CONDITIONS	V _{CC}	T _A = 25°C			–40°C to +85°C		–40°C to +125°C		UNIT
			MIN	TYP ⁽¹⁾	MAX	MIN	MAX	MIN	MAX	
V _{OH}	I _{OH} = –100μA	1.65V to 3.6V	V _{CC} – 0.2			V _{CC} – 0.2		V _{CC} – 0.2		V
	I _{OH} = –4mA	1.65V	1.2			1.2		1.2		
	I _{OH} = –8mA	2.3V	1.7			1.7		1.7		
	I _{OH} = –12mA	2.7V	2.2			2.2		2.2		
		3V	2.4			2.4		2.4		
I _{OH} = –24mA	3V	2.2			2.2		2.2			
V _{OL}	I _{OL} = 100μA	1.65V to 3.6V				0.2		0.2		V
	I _{OL} = 4mA	1.65V				0.45		0.45		
	I _{OL} = 8mA	2.3V				0.7		0.7		
	I _{OL} = 12mA	2.7V				0.4		0.4		
	I _{OL} = 24mA	3V				0.55		0.55		
I _I	V _I = 5.5V or GND	3.6V				±5		±5		μA
I _{CC}	V _I = V _{CC} or GND, I _O = 0	3.6V				10		10		μA
ΔI _{CC}	One input at V _{CC} – 0.6V, Other inputs at V _{CC} or GND	2.7V to 3.6V				500		500		μA
C _i	V _I = V _{CC} or GND	3.3V				4.5				pF

(1) All typical values are at V_{CC} = 3.3V, T_A = 25°C.

5.6 Timing Requirements, –40°C to +85°C

over recommended operating free-air temperature range (unless otherwise noted) (see Figure 6-1)

		V _{CC} = 1.8V ±0.15V		V _{CC} = 2.5V ±0.2V		V _{CC} = 2.7V		V _{CC} = 3.3V ±0.3V		UNIT	
		MIN	MAX	MIN	MAX	MIN	MAX	MIN	MAX		
f _{clock}	Clock frequency	120		150		150		150		MHz	
t _w	Pulse duration, CLK high or low	4.2		3.3		3.3		3.3		ns	
t _{su}	Setup time	Data before CLK↓	5.8		3.2		3.1		2.3		ns
		PRE or CLR inactive	5		2.8		2.4		1.1		
t _h	Hold time, data after CLK↓	6.2		4.4		2.5		0.7		ns	

5.7 Timing Requirements, –40°C to +125°C

over recommended operating free-air temperature range (unless otherwise noted) (see Figure 6-1)

		V _{CC} = 1.8V ±0.15V		V _{CC} = 2.5V ±0.2V		V _{CC} = 2.7V		V _{CC} = 3.3V ±0.3V		UNIT	
		MIN	MAX	MIN	MAX	MIN	MAX	MIN	MAX		
f _{clock}	Clock frequency	120		150		150		150		MHz	
t _w	Pulse duration, CLK high or low	4.1		3.3		3.3		3.3		ns	
t _{su}	Setup time	Data before CLK↓	6		3.2		3.1		2.3		ns
		PRE or CLR inactive	5		2.8		2.4		1.1		
t _h	Hold time, data after CLK↓	6.2		4.7		2.5		0.7		ns	

5.8 Switching Characteristics, –40°C to +85°C

over recommended operating free-air temperature range (unless otherwise noted) (see Figure 6-1)

PARAMETER	FROM (INPUT)	TO (OUTPUT)	$V_{CC} = 1.8\text{ V} \pm 0.15\text{ V}$		$V_{CC} = 2.5\text{ V} \pm 0.2\text{ V}$		$V_{CC} = 2.7\text{ V}$		$V_{CC} = 3.3\text{ V} \pm 0.3\text{ V}$			UNIT
			MIN	MAX	MIN	MAX	MIN	MAX	MIN	TYP	MAX	
f_{max}			150		150		150		150			MHz
t_{pd}	CLR or PRE	Q or \bar{Q}		6.7		4.3		5.5	1	3.4	4.8	ns
	CLK			6.8		4.5		7.1	1	3.5	5.9	

5.9 Switching Characteristics, –40°C to +125°C

over operating free-air temperature range (unless otherwise noted)

PARAMETER	FROM (INPUT)	TO (OUTPUT)	$V_{CC} = 1.8\text{ V} \pm 0.15\text{ V}$		$V_{CC} = 2.5\text{ V} \pm 0.2\text{ V}$		$V_{CC} = 2.7\text{ V}$		$V_{CC} = 3.3\text{ V} \pm 0.3\text{ V}$			UNIT
			MIN	MAX	MIN	MAX	MIN	MAX	MIN	TYP	MAX	
f_{max}			120		150		150		150			MHz
t_{pd}	CLR or PRE	Q or \bar{Q}		7.0		4.5		6	1	3.4	5.3	ns
	CLK			6.9		4.6		7.6	1	3.5	6.4	

5.10 Operating Characteristics

$T_A = 25^\circ\text{C}$

PARAMETER	TEST CONDITIONS	$V_{CC} = 1.8\text{ V}$	$V_{CC} = 2.5\text{ V}$	$V_{CC} = 3.3\text{ V}$	UNIT
		TYP	TYP	TYP	
C_{pd} Power dissipation capacitance	$f = 10\text{ MHz}$	See ⁽¹⁾	See ⁽¹⁾	24	pF

(1) This information was not available at the time of publication.

5.11 Typical Characteristics

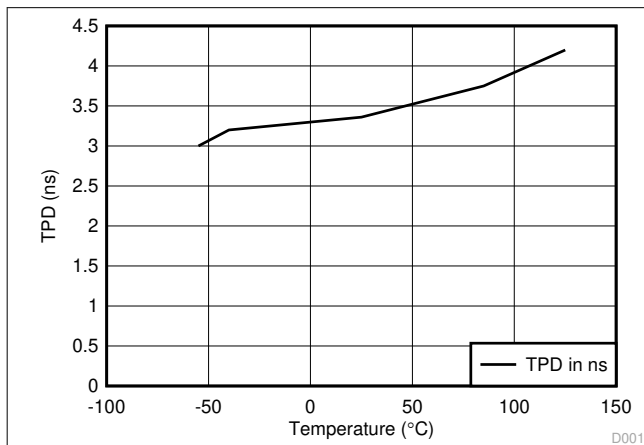

Figure 5-1. TPD vs Temperature

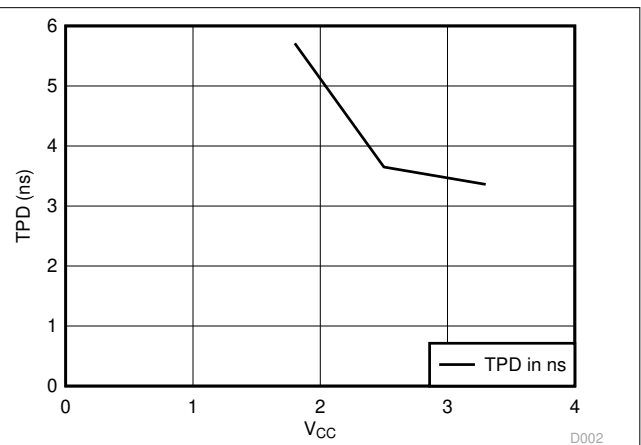
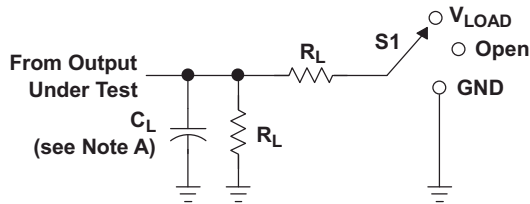

Figure 5-2. TPD vs V_{CC} at 25°C

6 Parameter Measurement Information



LOAD CIRCUIT

TEST	S1
t_{PLH}/t_{PHL}	Open
t_{PLZ}/t_{PZL}	V_{LOAD}
t_{PHZ}/t_{PZH}	GND

V_{CC}	INPUTS		V_M	V_{LOAD}	C_L	R_L	V_{Δ}
	V_I	t_r/t_f					
$1.8\text{ V} \pm 0.15\text{ V}$	V_{CC}	$\leq 2\text{ ns}$	$V_{CC}/2$	$2 \times V_{CC}$	30 pF	1 k Ω	0.15 V
$2.5\text{ V} \pm 0.2\text{ V}$	V_{CC}	$\leq 2\text{ ns}$	$V_{CC}/2$	$2 \times V_{CC}$	30 pF	500 Ω	0.15 V
2.7 V	2.7 V	$\leq 2.5\text{ ns}$	1.5 V	6 V	50 pF	500 Ω	0.3 V
$3.3\text{ V} \pm 0.3\text{ V}$	2.7 V	$\leq 2.5\text{ ns}$	1.5 V	6 V	50 pF	500 Ω	0.3 V

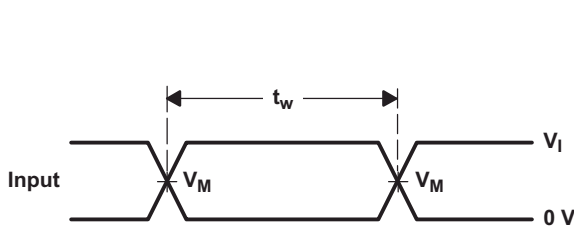

VOLTAGE WAVEFORMS
PULSE DURATION

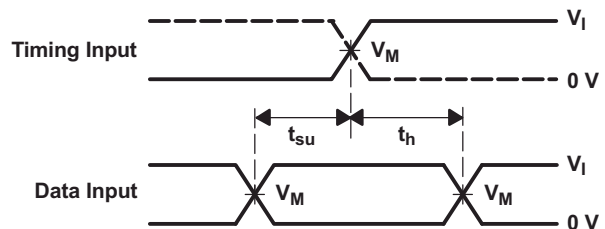

VOLTAGE WAVEFORMS
SETUP AND HOLD TIMES

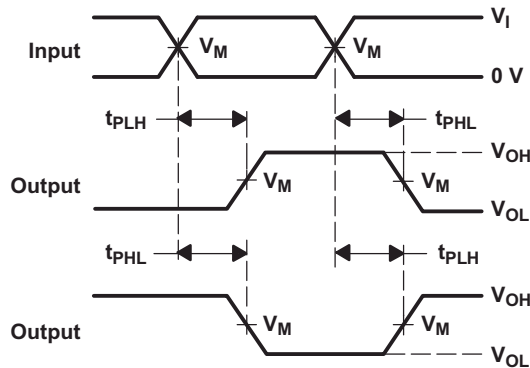

VOLTAGE WAVEFORMS
PROPAGATION DELAY TIMES
INVERTING AND NONINVERTING OUTPUTS

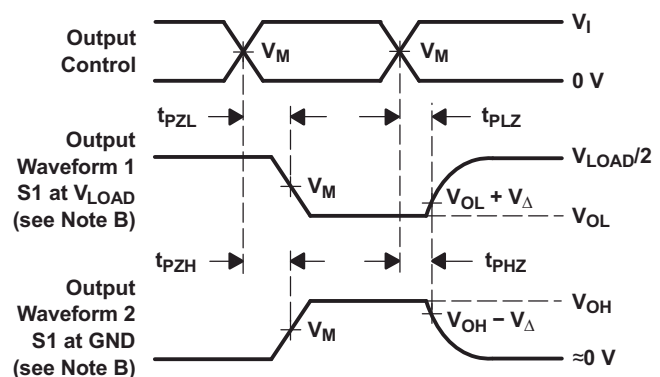

VOLTAGE WAVEFORMS
ENABLE AND DISABLE TIMES
LOW- AND HIGH-LEVEL ENABLING

- NOTES:
- A. C_L includes probe and jig capacitance.
 - B. Waveform 1 is for an output with internal conditions such that the output is low, except when disabled by the output control. Waveform 2 is for an output with internal conditions such that the output is high, except when disabled by the output control.
 - C. All input pulses are supplied by generators having the following characteristics: PRR $\leq 10\text{ MHz}$, $Z_O = 50\ \Omega$.
 - D. The outputs are measured one at a time, with one transition per measurement.
 - E. t_{PLZ} and t_{PHZ} are the same as t_{dis} .
 - F. t_{PZL} and t_{PZH} are the same as t_{en} .
 - G. t_{PLH} and t_{PHL} are the same as t_{pd} .
 - H. All parameters and waveforms are not applicable to all devices.

Figure 6-1. Load Circuit and Voltage Waveforms

7 Detailed Description

7.1 Overview

This dual negative-edge-triggered J-K flip-flop is designed for 1.65V to 3.6V V_{CC} operation.

A low level at the preset (\overline{PRE}) or clear (\overline{CLR}) inputs sets or resets the outputs, regardless of the levels of the other inputs. When \overline{PRE} and \overline{CLR} are inactive (high), data at the J and K inputs meeting the setup-time requirements is transferred to the outputs on the negative-going edge of the clock pulse. Clock triggering occurs at a voltage level and is not directly related to the rise time of the clock pulse. Following the hold-time interval, data at the J and K inputs can be changed without affecting the levels at the outputs. The SN74LVC112A can perform as a toggle flip-flop by tying J and K high.

Inputs can be driven from either 3.3V or 5V devices. This feature allows the use of these devices as translators in a mixed 3.3V/5V system environment.

7.2 Functional Block Diagram

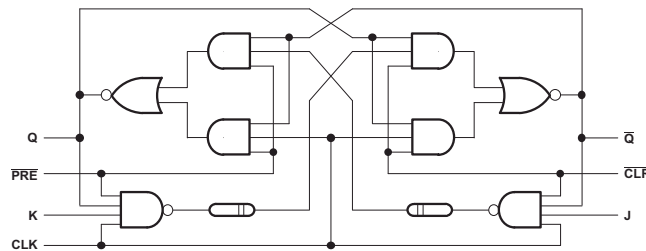

Figure 7-1. Logic Diagram, Each Flip-Flop (Positive Logic)

7.3 Feature Description

- Wide operating voltage range
 - Operates from 1.65V to 3.6V
- Allows down voltage translation
 - Inputs accept voltages to 5.5V
- I_{off} feature
 - Allows voltages on the inputs and outputs when V_{CC} is 0V

7.4 Device Functional Modes

Table 7-1. Function Table

INPUTS					OUTPUTS	
\overline{PRE}	\overline{CLR}	CLK	J	K	Q	\overline{Q}
L	H	X	X	X	H	L
H	L	X	X	X	L	H
L	L	X	X	X	H ⁽¹⁾	H ⁽¹⁾
H	H	↓	L	L	Q_0	\overline{Q}_0
H	H	↓	H	L	H	L
H	H	↓	L	H	L	H
H	H	↓	H	H	Toggle	
H	H	H	X	X	Q_0	\overline{Q}_0

- (1) The output levels in this configuration may not meet the minimum levels for V_{OH} . Furthermore, this configuration is nonstable; that is, it does not persist when either \overline{PRE} or \overline{CLR} returns to its inactive (high) level.

8 Application and Implementation

Note

Information in the following applications sections is not part of the TI component specification, and TI does not warrant its accuracy or completeness. TI's customers are responsible for determining suitability of components for their purposes, as well as validating and testing their design implementation to confirm system functionality.

8.1 Application Information

SN74LVC112A is a high-drive CMOS device that can be used for a multitude of bus interface type applications where the data needs to be retained or latched. It can produce 24mA of drive current at 3.3V, making it ideal for driving multiple outputs and good for high-speed applications up to 150MHz. The inputs are 5.5V tolerant allowing it to translate down to V_{CC} .

8.2 Typical Application

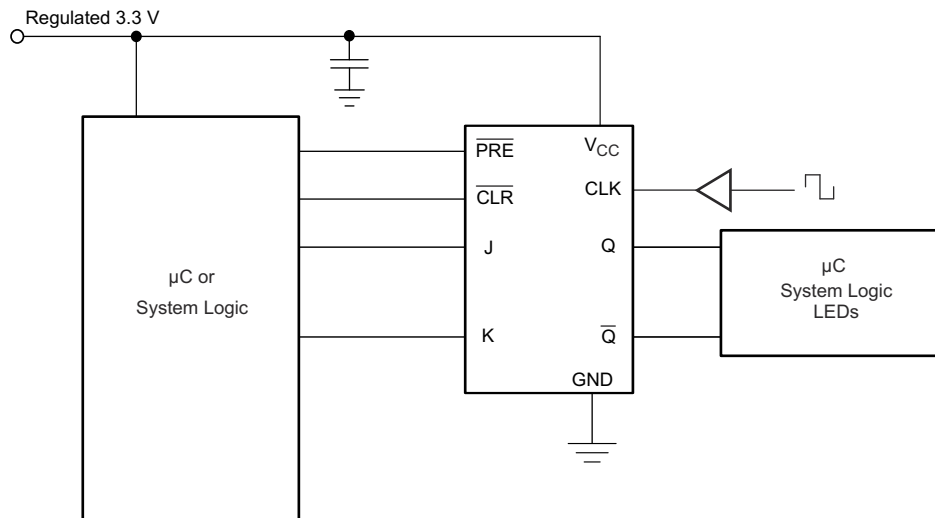

Figure 8-1. Typical Application Schematic

8.2.1 Design Requirements

This device uses CMOS technology and has balanced output drive. Care should be taken to avoid bus contention because it can drive currents that may exceed maximum limits. The high drive will also create fast edges into light loads, so routing and load conditions should be considered to prevent ringing.

8.2.2 Detailed Design Procedure

1. Recommended Input Conditions
 - For rise time and fall time specifications, see $\Delta t/\Delta V$ in the [Recommended Operating Conditions](#) table.
 - For specified High and low levels, see V_{IH} and V_{IL} in the [Recommended Operating Conditions](#) table.
 - Inputs are overvoltage tolerant allowing them to go as high as 5.5V at any valid V_{CC} .
2. Recommend Output Conditions
 - Load currents should not exceed 50mA per output and 100mA total for the part.
 - Outputs should not be pulled above V_{CC} .

8.2.3 Application Curve

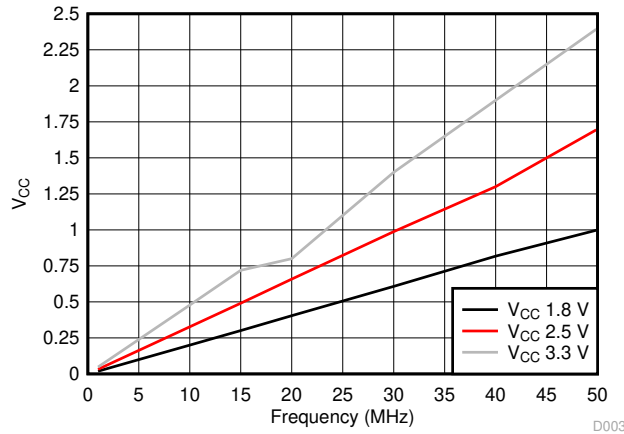

Figure 8-2. I_{CC} vs Frequency

8.3 Power Supply Recommendations

The power supply can be any voltage between the MIN and MAX supply voltage rating located in the [Recommended Operating Conditions](#) table.

Each V_{CC} pin should have a good bypass capacitor to prevent power disturbance. For devices with a single supply, 0.1 μF is recommended. If there are multiple V_{CC} pins, 0.01 μF or 0.022 μF is recommended for each power pin. It is acceptable to parallel multiple bypass caps to reject different frequencies of noise. A 0.1 μF and 1 μF are commonly used in parallel. The bypass capacitor should be installed as close to the power pin as possible for best results.

8.4 Layout

8.4.1 Layout Guidelines

Inputs should not float when using multiple bit logic devices. Functions or parts of functions of digital logic devices are unused in many cases. Some examples include situations in which only two inputs of a triple-input AND gate are used, or when only 3 of the 4-buffer gates are used. Such input pins should not be left unconnected because the undefined voltages at the outside connections result in undefined operational states.

Specified in [Figure 8-3](#) are rules that must be observed under all circumstances. All unused inputs of digital logic devices must be connected to a high or low bias to prevent them from floating. The logic level that should be applied to any particular unused input depends on the function of the device. Generally they will be tied to GND or V_{CC} , whichever makes more sense or is more convenient. It is acceptable to float outputs unless the part is a transceiver.

8.4.2 Layout Example

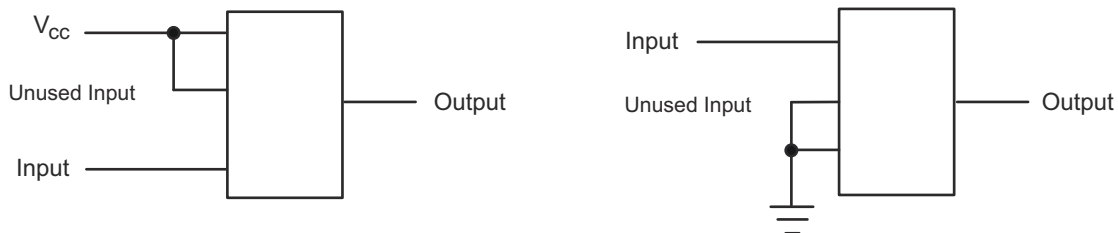

Figure 8-3. Layout Diagram

9 Device and Documentation Support

9.1 Receiving Notification of Documentation Updates

To receive notification of documentation updates, navigate to the device product folder on ti.com. Click on *Notifications* to register and receive a weekly digest of any product information that has changed. For change details, review the revision history included in any revised document.

9.2 Support Resources

[TI E2E™ support forums](#) are an engineer's go-to source for fast, verified answers and design help — straight from the experts. Search existing answers or ask your own question to get the quick design help you need.

Linked content is provided "AS IS" by the respective contributors. They do not constitute TI specifications and do not necessarily reflect TI's views; see TI's [Terms of Use](#).

9.3 Trademarks

TI E2E™ is a trademark of Texas Instruments.

All trademarks are the property of their respective owners.

9.4 Electrostatic Discharge Caution



This integrated circuit can be damaged by ESD. Texas Instruments recommends that all integrated circuits be handled with appropriate precautions. Failure to observe proper handling and installation procedures can cause damage.

ESD damage can range from subtle performance degradation to complete device failure. Precision integrated circuits may be more susceptible to damage because very small parametric changes could cause the device not to meet its published specifications.

9.5 Glossary

[TI Glossary](#) This glossary lists and explains terms, acronyms, and definitions.

10 Revision History

NOTE: Page numbers for previous revisions may differ from page numbers in the current version.

Changes from Revision N (December 2024) to Revision O (July 2025) Page

- Updated 85°C *Switching Characteristics* table for $V_{CC} = 1.8V$ and $2.5V$7
- Updated 125C *Switching Characteristics* table for $V_{CC} = 1.8$ and $2.5 V$7

Changes from Revision M (December 2014) to Revision N (December 2024) Page

- Updated the numbering format for tables, figures, and cross-references throughout the document..... 1
- Deleted references to machine model throughout the data sheet, and updated HBM and CDM values from 3000V to 2000V and 1500V to 1000V, respectively..... 1
- Updated R θ JA values: D = 90.6 to 118.1, DB = 107.1 to 122.5, NS = 90.7 to 117.5, PW = 122.6 to 141.8; updated D, DB, NS, and PW packages for R θ JC(top), R θ JB, Ψ JT, Ψ JB, and R θ JC(bot), all values in °C/W...5

Changes from Revision L (August 2004) to Revision M (December 2014) Page

- Added *Applications*, *Package Information* table, *Pin Functions* table, *ESD Ratings* table, *Thermal Information* table, *Typical Characteristics*, *Feature Description* section, *Device Functional Modes*, *Application and Implementation* section, *Power Supply Recommendations* section, *Layout* section, *Device and Documentation Support* section, and *Mechanical, Packaging, and Orderable Information* section..... 1
- Deleted *Ordering Information* table..... 1
- Changed MAX operating temperature to 125°C in *Recommended Operating Conditions* table.....5
- Added -40°C to +125°C temperature range to *Electrical Specifications* table.6

-
- Added *Timing Requirements* table for –40°C to 125°C temperature range..... 6
-

11 Mechanical, Packaging, and Orderable Information

The following pages include mechanical, packaging, and orderable information. This information is the most current data available for the designated devices. This data is subject to change without notice and revision of this document. For browser-based versions of this data sheet, refer to the left-hand navigation.

PACKAGING INFORMATION

Orderable part number	Status (1)	Material type (2)	Package Pins	Package qty Carrier	RoHS (3)	Lead finish/ Ball material (4)	MSL rating/ Peak reflow (5)	Op temp (°C)	Part marking (6)
SN74LVC112AD	Active	Production	SOIC (D) 16	40 TUBE	Yes	NIPDAU	Level-1-260C-UNLIM	-40 to 125	LVC112A
SN74LVC112AD.B	Active	Production	SOIC (D) 16	40 TUBE	Yes	NIPDAU	Level-1-260C-UNLIM	-40 to 125	LVC112A
SN74LVC112ADBR	Active	Production	SSOP (DB) 16	2000 LARGE T&R	Yes	NIPDAU	Level-1-260C-UNLIM	-40 to 125	LC112A
SN74LVC112ADBR.A	Active	Production	SSOP (DB) 16	2000 LARGE T&R	Yes	NIPDAU	Level-1-260C-UNLIM	-40 to 125	LC112A
SN74LVC112ADBR.B	Active	Production	SSOP (DB) 16	2000 LARGE T&R	Yes	NIPDAU	Level-1-260C-UNLIM	-40 to 125	LC112A
SN74LVC112ADGVR	Active	Production	TVSOP (DGV) 16	2000 LARGE T&R	Yes	NIPDAU	Level-1-260C-UNLIM	-40 to 125	LC112A
SN74LVC112ADGVR.B	Active	Production	TVSOP (DGV) 16	2000 LARGE T&R	Yes	NIPDAU	Level-1-260C-UNLIM	-40 to 125	LC112A
SN74LVC112ADR	Active	Production	SOIC (D) 16	2500 LARGE T&R	Yes	NIPDAU	Level-1-260C-UNLIM	-40 to 125	LVC112A
SN74LVC112ADR.A	Active	Production	SOIC (D) 16	2500 LARGE T&R	Yes	NIPDAU	Level-1-260C-UNLIM	-40 to 125	LVC112A
SN74LVC112ADR.B	Active	Production	SOIC (D) 16	2500 LARGE T&R	Yes	NIPDAU	Level-1-260C-UNLIM	-40 to 125	LVC112A
SN74LVC112ADT	Active	Production	SOIC (D) 16	250 SMALL T&R	Yes	NIPDAU	Level-1-260C-UNLIM	-40 to 125	LVC112A
SN74LVC112ADT.B	Active	Production	SOIC (D) 16	250 SMALL T&R	Yes	NIPDAU	Level-1-260C-UNLIM	-40 to 125	LVC112A
SN74LVC112ANSR	Active	Production	SOP (NS) 16	2000 LARGE T&R	Yes	NIPDAU	Level-1-260C-UNLIM	-40 to 125	LVC112A
SN74LVC112ANSR.A	Active	Production	SOP (NS) 16	2000 LARGE T&R	Yes	NIPDAU	Level-1-260C-UNLIM	-40 to 125	LVC112A
SN74LVC112ANSR.B	Active	Production	SOP (NS) 16	2000 LARGE T&R	Yes	NIPDAU	Level-1-260C-UNLIM	-40 to 125	LVC112A
SN74LVC112APW	Active	Production	TSSOP (PW) 16	90 TUBE	Yes	NIPDAU	Level-1-260C-UNLIM	-40 to 125	LC112A
SN74LVC112APW.B	Active	Production	TSSOP (PW) 16	90 TUBE	Yes	NIPDAU	Level-1-260C-UNLIM	-40 to 125	LC112A
SN74LVC112APWR	Active	Production	TSSOP (PW) 16	2000 LARGE T&R	Yes	NIPDAU	Level-1-260C-UNLIM	-40 to 125	LC112A
SN74LVC112APWR.A	Active	Production	TSSOP (PW) 16	2000 LARGE T&R	Yes	NIPDAU	Level-1-260C-UNLIM	-40 to 125	LC112A
SN74LVC112APWR.B	Active	Production	TSSOP (PW) 16	2000 LARGE T&R	Yes	NIPDAU	Level-1-260C-UNLIM	-40 to 125	LC112A
SN74LVC112APWRG4	Active	Production	TSSOP (PW) 16	2000 LARGE T&R	Yes	NIPDAU	Level-1-260C-UNLIM	-40 to 125	LC112A
SN74LVC112APWRG4.A	Active	Production	TSSOP (PW) 16	2000 LARGE T&R	Yes	NIPDAU	Level-1-260C-UNLIM	-40 to 125	LC112A
SN74LVC112APWRG4.B	Active	Production	TSSOP (PW) 16	2000 LARGE T&R	Yes	NIPDAU	Level-1-260C-UNLIM	-40 to 125	LC112A
SN74LVC112APWT	Active	Production	TSSOP (PW) 16	250 SMALL T&R	Yes	NIPDAU	Level-1-260C-UNLIM	-40 to 125	LC112A
SN74LVC112APWT.B	Active	Production	TSSOP (PW) 16	250 SMALL T&R	Yes	NIPDAU	Level-1-260C-UNLIM	-40 to 125	LC112A

⁽¹⁾ **Status:** For more details on status, see our [product life cycle](#).

- (2) **Material type:** When designated, preproduction parts are prototypes/experimental devices, and are not yet approved or released for full production. Testing and final process, including without limitation quality assurance, reliability performance testing, and/or process qualification, may not yet be complete, and this item is subject to further changes or possible discontinuation. If available for ordering, purchases will be subject to an additional waiver at checkout, and are intended for early internal evaluation purposes only. These items are sold without warranties of any kind.
- (3) **RoHS values:** Yes, No, RoHS Exempt. See the [TI RoHS Statement](#) for additional information and value definition.
- (4) **Lead finish/Ball material:** Parts may have multiple material finish options. Finish options are separated by a vertical ruled line. Lead finish/Ball material values may wrap to two lines if the finish value exceeds the maximum column width.
- (5) **MSL rating/Peak reflow:** The moisture sensitivity level ratings and peak solder (reflow) temperatures. In the event that a part has multiple moisture sensitivity ratings, only the lowest level per JEDEC standards is shown. Refer to the shipping label for the actual reflow temperature that will be used to mount the part to the printed circuit board.
- (6) **Part marking:** There may be an additional marking, which relates to the logo, the lot trace code information, or the environmental category of the part.

Multiple part markings will be inside parentheses. Only one part marking contained in parentheses and separated by a "~" will appear on a part. If a line is indented then it is a continuation of the previous line and the two combined represent the entire part marking for that device.

Important Information and Disclaimer: The information provided on this page represents TI's knowledge and belief as of the date that it is provided. TI bases its knowledge and belief on information provided by third parties, and makes no representation or warranty as to the accuracy of such information. Efforts are underway to better integrate information from third parties. TI has taken and continues to take reasonable steps to provide representative and accurate information but may not have conducted destructive testing or chemical analysis on incoming materials and chemicals. TI and TI suppliers consider certain information to be proprietary, and thus CAS numbers and other limited information may not be available for release.

In no event shall TI's liability arising out of such information exceed the total purchase price of the TI part(s) at issue in this document sold by TI to Customer on an annual basis.

TAPE AND REEL INFORMATION

QUADRANT ASSIGNMENTS FOR PIN 1 ORIENTATION IN TAPE

*All dimensions are nominal

Device	Package Type	Package Drawing	Pins	SPQ	Reel Diameter (mm)	Reel Width W1 (mm)	A0 (mm)	B0 (mm)	K0 (mm)	P1 (mm)	W (mm)	Pin1 Quadrant
SN74LVC112ADBR	SSOP	DB	16	2000	330.0	16.4	8.35	6.6	2.4	12.0	16.0	Q1
SN74LVC112ADGVR	TVSOP	DGV	16	2000	330.0	12.4	6.8	4.0	1.6	8.0	12.0	Q1
SN74LVC112ADR	SOIC	D	16	2500	330.0	16.4	6.5	10.3	2.1	8.0	16.0	Q1
SN74LVC112ADR	SOIC	D	16	2500	330.0	16.4	6.5	10.3	2.1	8.0	16.0	Q1
SN74LVC112ANSR	SOP	NS	16	2000	330.0	16.4	8.1	10.4	2.5	12.0	16.0	Q1
SN74LVC112APWR	TSSOP	PW	16	2000	330.0	12.4	6.9	5.6	1.6	8.0	12.0	Q1
SN74LVC112APWRG4	TSSOP	PW	16	2000	330.0	12.4	6.9	5.6	1.6	8.0	12.0	Q1
SN74LVC112APWT	TSSOP	PW	16	250	330.0	12.4	6.9	5.6	1.6	8.0	12.0	Q1

TAPE AND REEL BOX DIMENSIONS

*All dimensions are nominal

Device	Package Type	Package Drawing	Pins	SPQ	Length (mm)	Width (mm)	Height (mm)
SN74LVC112ADBR	SSOP	DB	16	2000	353.0	353.0	32.0
SN74LVC112ADGVR	TVSOP	DGV	16	2000	353.0	353.0	32.0
SN74LVC112ADR	SOIC	D	16	2500	353.0	353.0	32.0
SN74LVC112ADR	SOIC	D	16	2500	340.5	336.1	32.0
SN74LVC112ANSR	SOP	NS	16	2000	353.0	353.0	32.0
SN74LVC112APWR	TSSOP	PW	16	2000	353.0	353.0	32.0
SN74LVC112APWRG4	TSSOP	PW	16	2000	353.0	353.0	32.0
SN74LVC112APWT	TSSOP	PW	16	250	353.0	353.0	32.0

TUBE

*All dimensions are nominal

Device	Package Name	Package Type	Pins	SPQ	L (mm)	W (mm)	T (μm)	B (mm)
SN74LVC112AD	D	SOIC	16	40	507	8	3940	4.32
SN74LVC112AD.B	D	SOIC	16	40	507	8	3940	4.32
SN74LVC112APW	PW	TSSOP	16	90	530	10.2	3600	3.5
SN74LVC112APW.B	PW	TSSOP	16	90	530	10.2	3600	3.5



PACKAGE OUTLINE

NS0016A

SOP - 2.00 mm max height

SOP

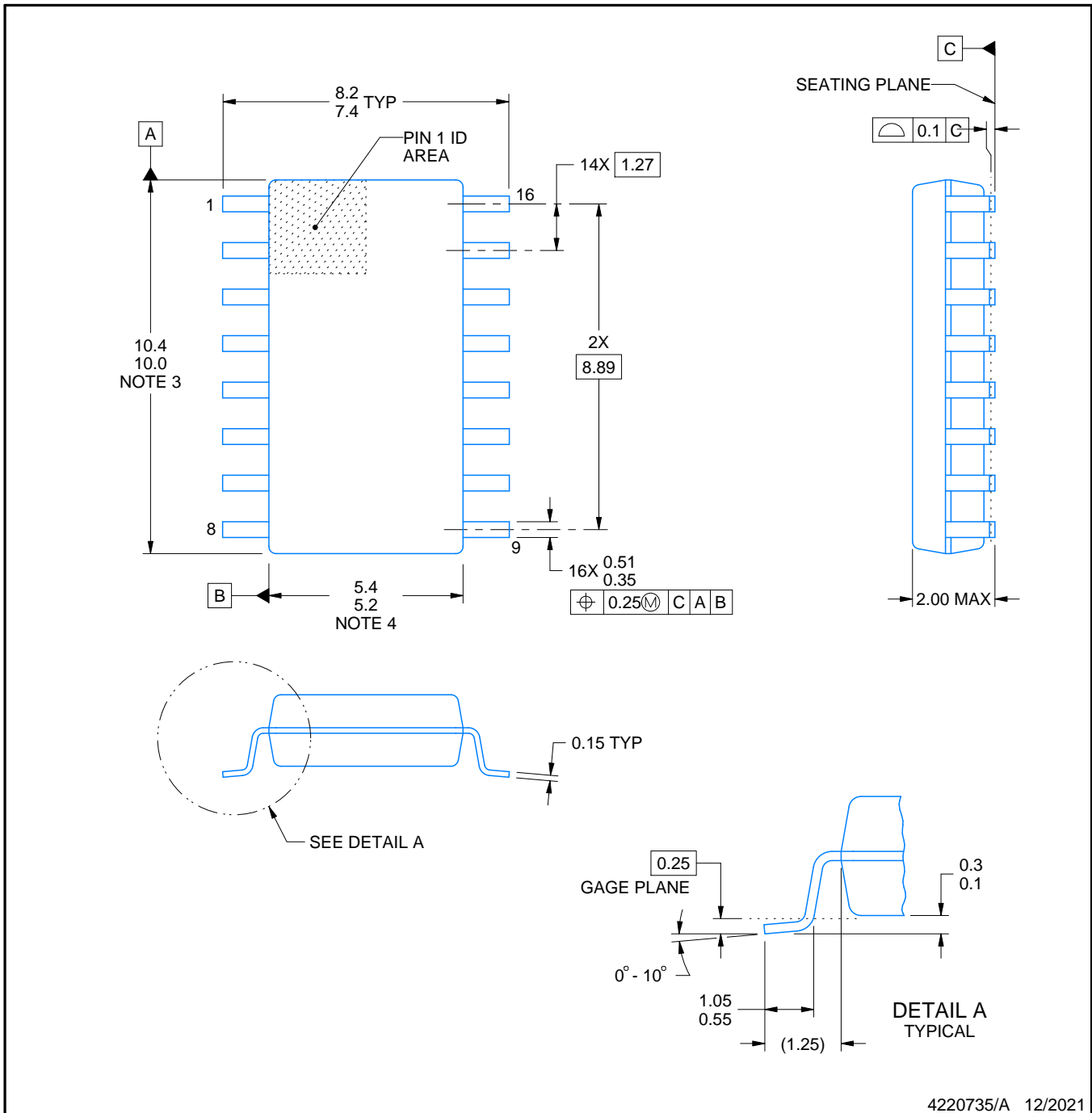

4220735/A 12/2021

NOTES:

1. All linear dimensions are in millimeters. Dimensions in parenthesis are for reference only. Dimensioning and tolerancing per ASME Y14.5M.
2. This drawing is subject to change without notice.
3. This dimension does not include mold flash, protrusions, or gate burrs. Mold flash, protrusions, or gate burrs shall not exceed 0.15 mm, per side.
4. This dimension does not include interlead flash. Interlead flash shall not exceed 0.25 mm, per side.

EXAMPLE BOARD LAYOUT

NS0016A

SOP - 2.00 mm max height

SOP

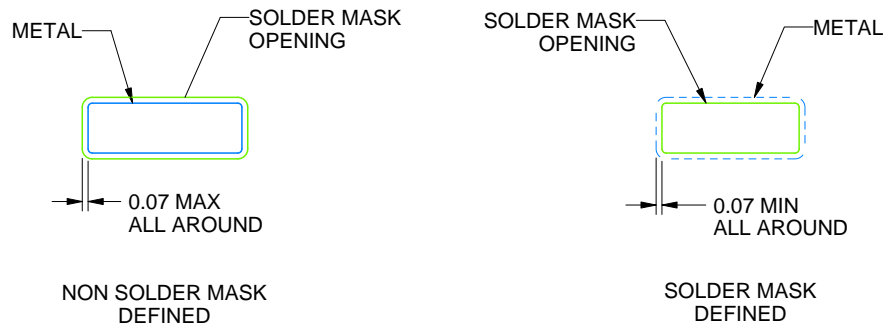

4220735/A 12/2021

NOTES: (continued)

5. Publication IPC-7351 may have alternate designs.

6. Solder mask tolerances between and around signal pads can vary based on board fabrication site.

EXAMPLE STENCIL DESIGN

NS0016A

SOP - 2.00 mm max height

SOP



SOLDER PASTE EXAMPLE
BASED ON 0.125 mm THICK STENCIL
SCALE:7X

4220735/A 12/2021

NOTES: (continued)

7. Laser cutting apertures with trapezoidal walls and rounded corners may offer better paste release. IPC-7525 may have alternate design recommendations.
8. Board assembly site may have different recommendations for stencil design.

D (R-PDSO-G16)

PLASTIC SMALL OUTLINE



- NOTES:
- A. All linear dimensions are in inches (millimeters).
 - B. This drawing is subject to change without notice.
 - C. Body length does not include mold flash, protrusions, or gate burrs. Mold flash, protrusions, or gate burrs shall not exceed 0.006 (0,15) each side.
 - D. Body width does not include interlead flash. Interlead flash shall not exceed 0.017 (0,43) each side.
 - E. Reference JEDEC MS-012 variation AC.

DB0016A



PACKAGE OUTLINE

SSOP - 2 mm max height

SMALL OUTLINE PACKAGE



4220763/A 05/2022

NOTES:

1. All linear dimensions are in millimeters. Any dimensions in parenthesis are for reference only. Dimensioning and tolerancing per ASME Y14.5M.
2. This drawing is subject to change without notice.
3. This dimension does not include mold flash, protrusions, or gate burrs. Mold flash, protrusions, or gate burrs shall not exceed 0.15 mm per side.
4. Reference JEDEC registration MO-150.

EXAMPLE BOARD LAYOUT

DB0016A

SSOP - 2 mm max height

SMALL OUTLINE PACKAGE



LAND PATTERN EXAMPLE
EXPOSED METAL SHOWN
SCALE: 10X



4220763/A 05/2022

NOTES: (continued)

- 5. Publication IPC-7351 may have alternate designs.
- 6. Solder mask tolerances between and around signal pads can vary based on board fabrication site.

EXAMPLE STENCIL DESIGN

DB0016A

SSOP - 2 mm max height

SMALL OUTLINE PACKAGE

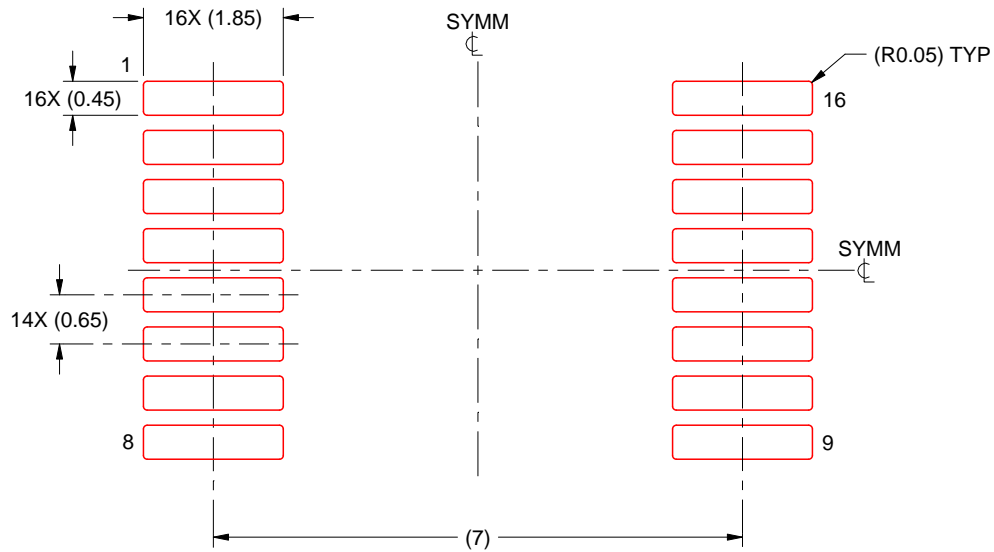

SOLDER PASTE EXAMPLE
BASED ON 0.125 mm THICK STENCIL
SCALE: 10X

4220763/A 05/2022

NOTES: (continued)

7. Laser cutting apertures with trapezoidal walls and rounded corners may offer better paste release. IPC-7525 may have alternate design recommendations.
8. Board assembly site may have different recommendations for stencil design.

DGV (R-PDSO-G**)

PLASTIC SMALL-OUTLINE

24 PINS SHOWN

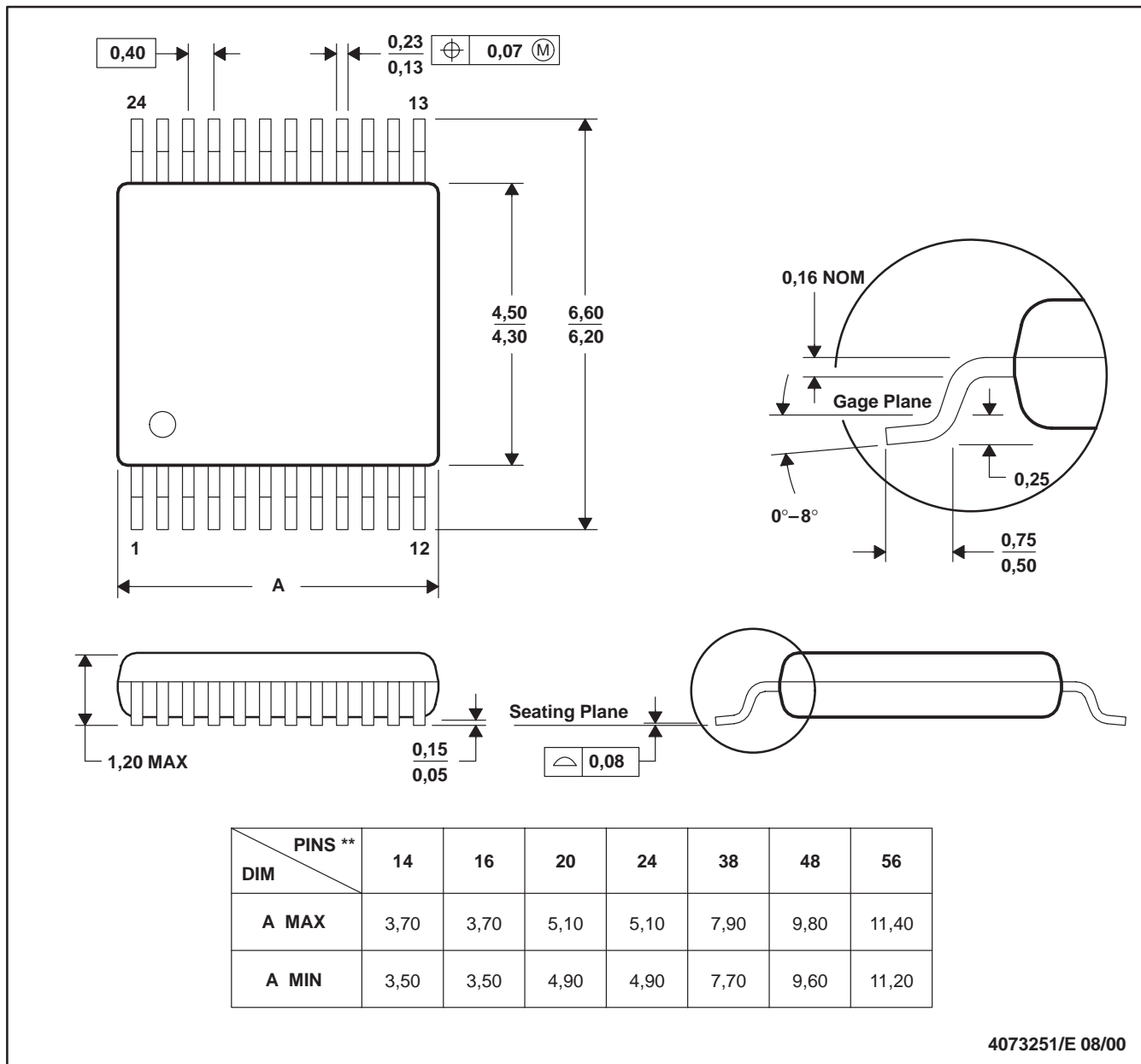

- NOTES: A. All linear dimensions are in millimeters.
 B. This drawing is subject to change without notice.
 C. Body dimensions do not include mold flash or protrusion, not to exceed 0,15 per side.
 D. Falls within JEDEC: 24/48 Pins – MO-153
 14/16/20/56 Pins – MO-194

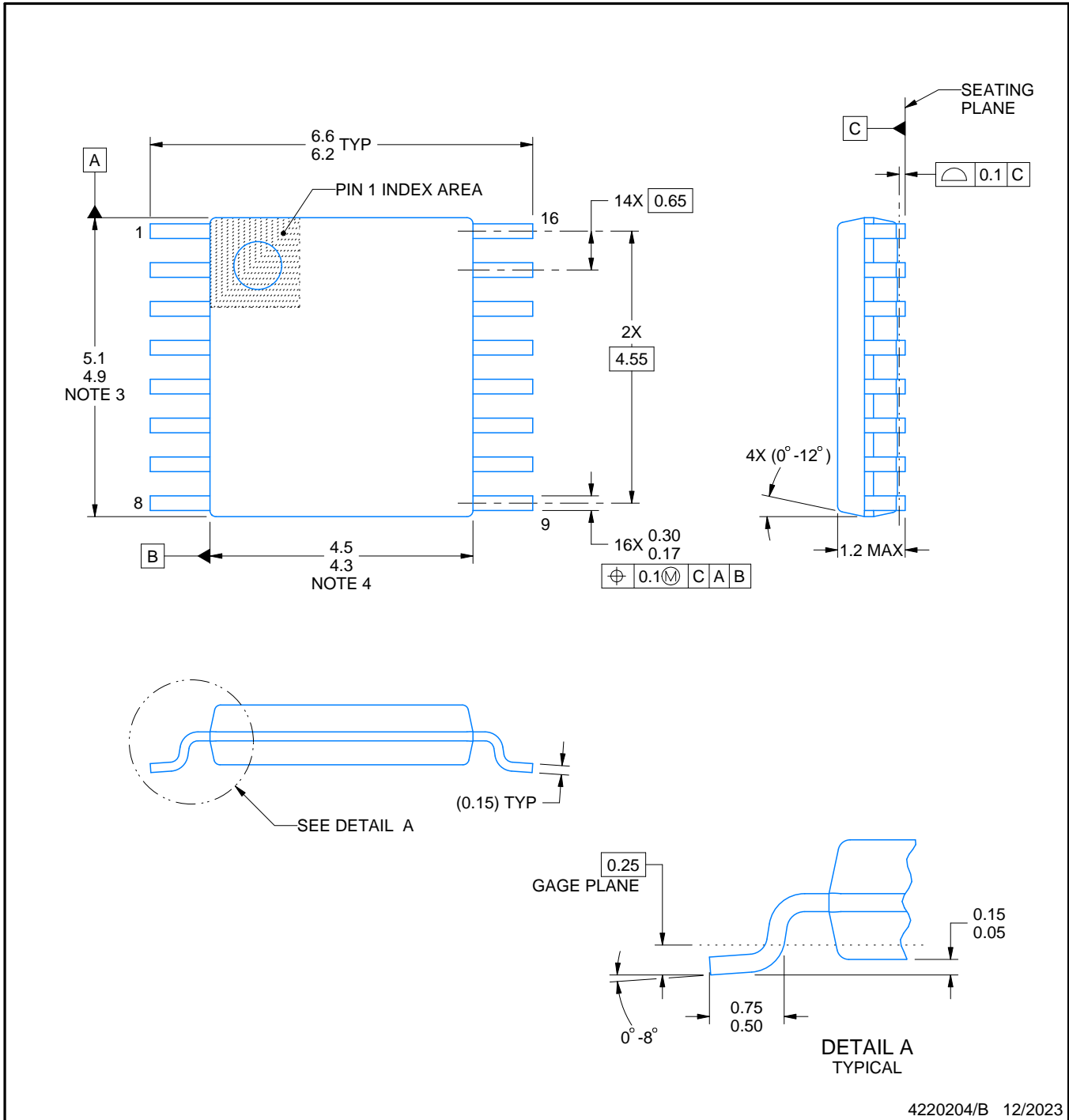

4220204/B 12/2023

NOTES:

1. All linear dimensions are in millimeters. Any dimensions in parenthesis are for reference only. Dimensioning and tolerancing per ASME Y14.5M.
2. This drawing is subject to change without notice.
3. This dimension does not include mold flash, protrusions, or gate burrs. Mold flash, protrusions, or gate burrs shall not exceed 0.15 mm per side.
4. This dimension does not include interlead flash. Interlead flash shall not exceed 0.25 mm per side.
5. Reference JEDEC registration MO-153.

EXAMPLE BOARD LAYOUT

PW0016A

TSSOP - 1.2 mm max height

SMALL OUTLINE PACKAGE



LAND PATTERN EXAMPLE
EXPOSED METAL SHOWN
SCALE: 10X



SOLDER MASK DETAILS

4220204/B 12/2023

NOTES: (continued)

- 6. Publication IPC-7351 may have alternate designs.
- 7. Solder mask tolerances between and around signal pads can vary based on board fabrication site.

EXAMPLE STENCIL DESIGN

PW0016A

TSSOP - 1.2 mm max height

SMALL OUTLINE PACKAGE

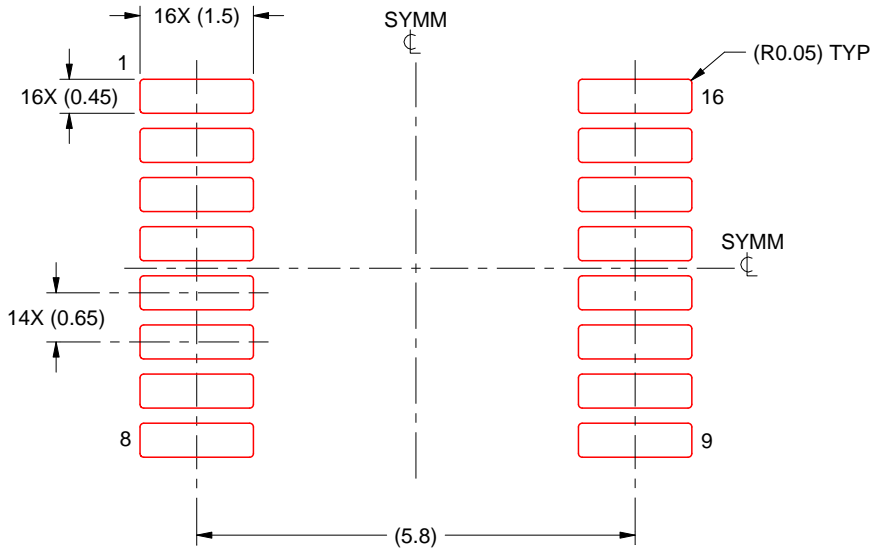

SOLDER PASTE EXAMPLE
BASED ON 0.125 mm THICK STENCIL
SCALE: 10X

4220204/B 12/2023

NOTES: (continued)

8. Laser cutting apertures with trapezoidal walls and rounded corners may offer better paste release. IPC-7525 may have alternate design recommendations.
9. Board assembly site may have different recommendations for stencil design.

IMPORTANT NOTICE AND DISCLAIMER

TI PROVIDES TECHNICAL AND RELIABILITY DATA (INCLUDING DATASHEETS), DESIGN RESOURCES (INCLUDING REFERENCE DESIGNS), APPLICATION OR OTHER DESIGN ADVICE, WEB TOOLS, SAFETY INFORMATION, AND OTHER RESOURCES "AS IS" AND WITH ALL FAULTS, AND DISCLAIMS ALL WARRANTIES, EXPRESS AND IMPLIED, INCLUDING WITHOUT LIMITATION ANY IMPLIED WARRANTIES OF MERCHANTABILITY, FITNESS FOR A PARTICULAR PURPOSE OR NON-INFRINGEMENT OF THIRD PARTY INTELLECTUAL PROPERTY RIGHTS.

These resources are intended for skilled developers designing with TI products. You are solely responsible for (1) selecting the appropriate TI products for your application, (2) designing, validating and testing your application, and (3) ensuring your application meets applicable standards, and any other safety, security, regulatory or other requirements.

These resources are subject to change without notice. TI grants you permission to use these resources only for development of an application that uses the TI products described in the resource. Other reproduction and display of these resources is prohibited. No license is granted to any other TI intellectual property right or to any third party intellectual property right. TI disclaims responsibility for, and you fully indemnify TI and its representatives against any claims, damages, costs, losses, and liabilities arising out of your use of these resources.

TI's products are provided subject to [TI's Terms of Sale](#), [TI's General Quality Guidelines](#), or other applicable terms available either on ti.com or provided in conjunction with such TI products. TI's provision of these resources does not expand or otherwise alter TI's applicable warranties or warranty disclaimers for TI products. Unless TI explicitly designates a product as custom or customer-specified, TI products are standard, catalog, general purpose devices.

TI objects to and rejects any additional or different terms you may propose.

Copyright © 2026, Texas Instruments Incorporated

Last updated 10/2025

Looking for pricing, stock, or lifecycle information?

Click below to explore more details on WIN SOURCE:

 [View SN74LVC112ADBR on WIN SOURCE](#)

 [Texas Instruments](#) Information

Optimize Your Supply Chain with WIN SOURCE Solutions

-  Global Sourcing Solution
-  Obsolete Management
-  Cost Control Management
-  Shortage Management
-  Alternative Solution
-  Excess Inventory Management