

Description

The Microchip MTCH1060 Capacitive Touch Controller with digital output provides a simple way to add robust water-tolerant touch detection or proximity sensing to any application. This device implements up to six capacitive sensors with Driven Shield+ capability. Sensitivity, measurement period and oversampling can be easily configured via three dedicated pins at run-time, enabling the optimization of power consumption. In addition, MTCH1060 provides Easy Tune-enabling out of the box usage even under changing noise conditions. The MTCH1060 embeds advanced optimization algorithms to actively suppress noise from the signal to achieve reliable touch detection in challenging noise environments.

The MTCH1060 provides up to six capacitive touch and proximity detection sensors which can work through plastic, wood or metal front panels with Microchip's proprietary Metal over Capacitive (MoC) technology. It supports a wide range of conductive materials as sensors, such as copper pads on PCB, silver ink, PEDOT carbon printing on plastic film and Indium Tin Oxide (ITO) pads. Individual open-drain active-low output will communicate the state of each sensor to a host microcontroller or drive an indication LED.

Features

- Capacitive Touch Sensing
- High Signal to Noise Ratio (SNR)
- Adjustable Sensitivity
- Multi-Stage Active Noise Suppression Filters
- Automatic Environmental Compensation
- Water Tolerant Touch
- Easy Tune (Ability to Auto-Tune Sensitivity at Run-Time)
- Flexible Single-Button Mode
- Support a Wide Range of Sensor Shapes and Sizes
- Touch Indication by OUT Pin Level
- Optional Tune Data
- Option to Disable Sensor
- Detect Hysteresis
- Brown-out Protection
- Operating Voltage Range:
 - 2-5V
- Operating Temperature:
 - -40°C to +85°C
 - -40°C to +125°C

Table of Contents

Description.....	1
Features.....	1
1. Pin Diagram.....	4
2. Pin Configuration.....	5
3. Configuration.....	6
3.1. CFG0 (Measurement Period).....	7
3.2. CFG1 (Oversampling).....	7
3.3. CFG2 (Touch Sensitivity).....	8
3.4. Easy Tune	8
3.5. Single-Button Mode.....	10
3.6. Touch Tune Data.....	11
3.7. Power-up and Run-Time Configuration Summary.....	11
3.8. Further Preset Configurations.....	11
4. Touch Sensor.....	14
4.1. BUTTONx (Touch Electrodes).....	14
4.2. SHIELD (Driven Shield).....	14
5. Touch Output.....	15
5.1. OUTx.....	15
6. Example Circuit.....	16
7. Response Time.....	17
7.1. Confirmation Scan.....	17
7.2. Formula to Calculate Response Time.....	18
7.3. Worst-Case and Best-Case Response Time.....	19
7.4. Worst-Case Response Time (ms).....	20
8. Power Consumption.....	23
8.1. Single-Button Mode Enabled.....	23
8.2. Single-Button Mode Disabled.....	23
9. Specification.....	25
9.1. Disclaimer.....	25
9.2. Electrical Specification	25
9.3. General Operating Ratings.....	25
9.4. I/O Pin Characteristics.....	26
10. Package Marking.....	27
10.1. Package Marking.....	27
11. Package Drawing.....	28
11.1. 20-Pin VQFN.....	28
11.2. 20-Pin SSOP.....	31
12. Appendix	34

12.1. Static Input Voltages..... 34

12.2. Dynamic Input Voltages..... 34

12.3. Procedure to Visualize Touch Tune Data..... 35

13. Revision History 42

Microchip Information..... 43

 The Microchip Website..... 43

 Product Change Notification Service..... 43

 Customer Support..... 43

 Product Identification System..... 44

 Microchip Devices Code Protection Feature..... 44

 Legal Notice..... 44

 Trademarks..... 45

 Quality Management System..... 46

 Worldwide Sales and Service..... 47

1. Pin Diagram

Figure 1-1. VQFN Package

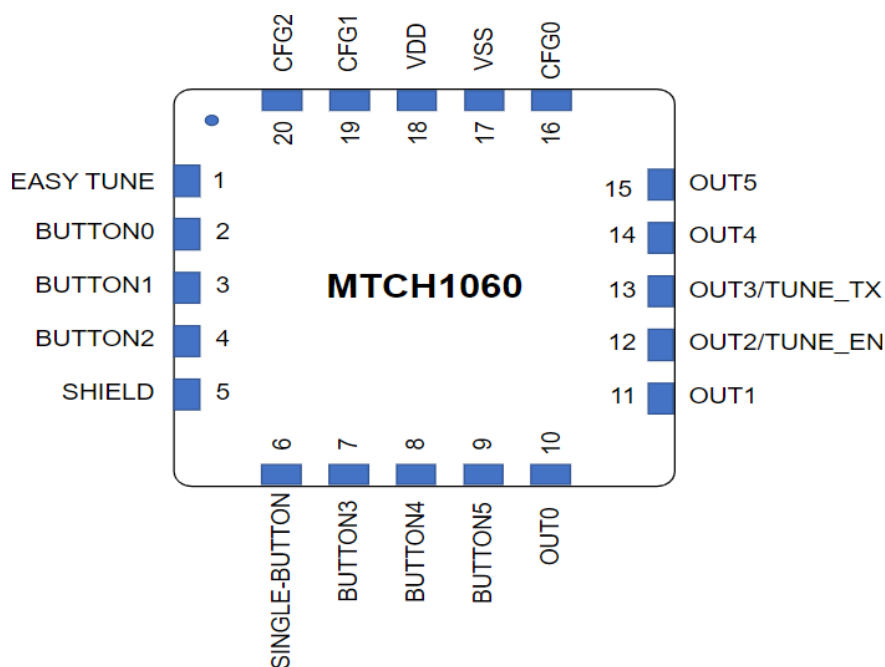

Note: Connecting the exposed bottom pad to V_{SS} is recommended. However, it must not be the only V_{SS} connection to the device.

Figure 1-2. SSOP Package

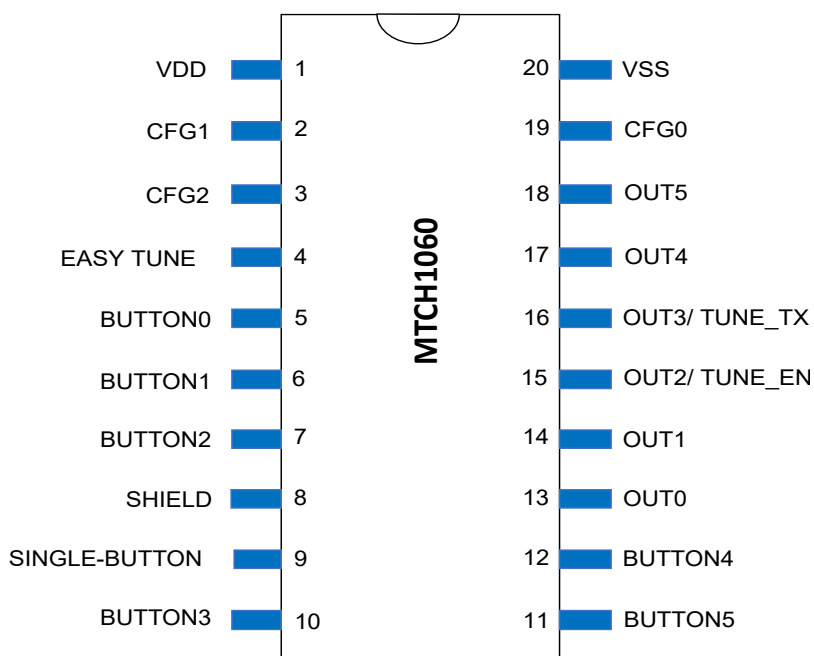

2. Pin Configuration

Table 2-1.

Name	20-Pin VQFN	20-Pin SSOP	Type	Comments	If Unused
EASY TUNE	1	4	I	Enable/Disable Easy Tune Feature	Connect to V _{DD}
BUTTON0	2	5	I	Sensor Electrode for Button 0	Should not be left open
BUTTON1	3	6	I	Sensor Electrode for Button 1	Connect to V _{DD}
BUTTON2	4	7	I	Sensor Electrode for Button 2	Connect to V _{DD}
SHIELD	5	8	O	Shield Electrode Output Driver	Leave open
SINGLE-BUTTON	6	9	I	Enable/Disable Single-Button Mode	Connect to V _{DD}
BUTTON3	7	10	I	Sensor Electrode for Button 3	Connect to V _{DD}
BUTTON4	8	11	I	Sensor Electrode for Button 4	Connect to V _{DD}
BUTTON5	9	12	I	Sensor Electrode for Button 5	Connect to V _{DD}
OUT0	10	13	OD	Touch Indication for Button 0	Leave open
OUT1	11	14	OD	Touch Indication for Button 1	Leave open
OUT2/TUNE_EN	12	15	OD/I	Touch Indication for Button 2 Or Enable Tune Data*	Leave open
OUT3/TUNE_TX	13	16	OD/O	Touch Indication for Button 3 Or Serial Data Transmission*	Leave open
OUT4	14	17	OD	Touch Indication for Button 4	Leave open
OUT5	15	18	OD	Touch Indication for Button 5	Leave open
CFG0	16	19	I	Response Time	Should not be left open
V _{SS}	17	20	P	Supply Ground	NA
V _{DD}	18	1	P	Power	NA
CFG1	19	2	I	Oversampling	Should not be left open
CFG2	20	3	I	Sensitivity	Should not be left open

I – Input; O – Output; OD – Open Drain.

* When Tune Data is enabled, touch indication will not be indicated on any of the OUTx pins.

3. Configuration

Three configuration input pins are provided on the MTCH1060 touch controller, and each pin controls one of the following configuration parameters:

- Measurement Period
- Oversampling
- Sensitivity

Inputs are set by applying a voltage level to the respective configuration pin. The [Appendix](#) provides information on how to generate these input voltages.

The MTCH1060 reads the configuration inputs at power-up, and sensor parameters are set accordingly. During the run-time, the CFGx inputs are measured once every two seconds, and configuration changes are applied at subsequent sensor measurements. Each input must be in the range of 0V to V_{DD} . CFG0 and CFG1 are split into four bands providing four options for each parameter, and CFG2 provides a continuous sensitivity adjustment between 0V and V_{DD} . These configurations are not updated if any sensor is in detect or if the MTCH1060 is configured in Single-Button mode. Refer to [Section 3.5 - Single-Button Mode](#) for further information.

Table 3-1.

Input Range	Configuration Selection
0V to $\frac{1}{4} V_{DD}$	A
$\frac{1}{4} V_{DD}$ to $\frac{1}{2} V_{DD}$	B
$\frac{1}{2} V_{DD}$ to $\frac{3}{4} V_{DD}$	C
$\frac{3}{4} V_{DD}$ to V_{DD}	D

In addition to CFGx pins, the MTCH1060 provides options to enable or disable the following features:

- Easy Tune
- Single-Button mode
- Touch Tune data

3.1 CFG0 (Measurement Period)

Table 3-2. Definitions

Response time	The time between physical contact until touch reporting on OUTx
Measurement time	Total time required to acquire (including oversampling) and post process touch signals for one sensor
Sleep time	The time the device sleeps between measurements
Measurement period (cycle time)	The time between the start of one measurement and the start of the following measurement, including: <ul style="list-style-type: none"> • Measurement time • Sleep time This time is selected via CFG0.
Number of sensors	There are six sensors for MTCH1060: <ul style="list-style-type: none"> • MTCH1060 has the option to disable up to five buttons • Depending on the number of sensors enabled, this parameter will change
Number of sensors touched	MTCH1060 allows the user to simultaneously touch multiple buttons. Depending on the number of simultaneously touched sensors, the response time will vary as the number of sensors simultaneously touched will be measured during confirmation scanning.

CFG0 selects a measurement period of up to 250 milliseconds (ms) for the target application. Touch measurements are performed periodically based on the measurement period. Once completing the measurement, the CPU goes into Sleep mode. This control allows the application designer to balance touch responsiveness against power consumption. Increasing the measurement period increases the response time and reduces power consumption as the device spends more time in Sleep mode. Reducing the measurement period provides a faster indication of touch contact.

Note: Configuration input is in non-ascending order. Settings expected in low-power applications are tied directly to V_{DD} or GND as this removes the necessity for a resistive divider bridge and associated bias current.

Select the longest measurement period at CFG option A (250 ms) or option D (100 ms) to achieve the low-power configurations.

Table 3-3.

Configuration	Measurement Period (ms)
A	250
B	Minimum (back-to-back)
C	50
D	100

3.2 CFG1 (Oversampling)

CFG1 selects the number of samples to take on each measurement cycle. Increased sampling provides more stable sensor operation and better tolerance for electrical noise, but at the cost of increased power consumption and response time. When Easy Tune is enabled, the minimum recommended oversampling is configured automatically, helping the user to avoid using a resistor divider on the CFG1 pin.

Note: Configuration input is in non-ascending order to avoid the necessity of resistive divider bias current. The lowest power option, eight samplings, is selected by CFG1 = 'A,' while the next lowest option, 16 samplings, is selected by CFG1 = 'D.'

Table 3-4.

Configuration	Samples*
A	8
B	64
C	32
D	16

*With the Easy Tune option enabled, a more automated selection of oversampling is applied. Refer to the Easy Tune option for further details.

3.3 CFG2 (Touch Sensitivity)

CFG2 determines the sensitivity of the touch sensor. A thicker touch cover, smaller sensor, or nearby ground-referenced conductors require higher sensitivity settings. Sensitivity does not affect power consumption or measurement time, except in the case of a high setting which can consume extra power by triggering unnecessary wake-up events. Configuring the sensitivity so the delta on the touch sensor is approximately 50 counts is recommended.

Additionally, matching the lower sensitivity settings with a higher oversampling for robust touch sensing is recommended. [Table 3-5](#) shows the recommended oversampling for each sensitivity setting.

Table 3-5.

Sensitivity Configuration *	Minimum Recommended Oversampling (CFG1)
0-63	8
64-127	16
128-191	32
192-255	64

*Sensitivity value varies linearly from 0 to 255 based on the voltage applied on the CFG2 pin - 0 corresponds to GND and 255 corresponds to V_{DD} .

Optional debug data can be used to tune the sensitivity. The [Appendix](#) provides the options for enabling Tune Data and viewing the required parameters.

Table 3-6.

Input Range	Sensitivity*
0V to V_{DD}	<ul style="list-style-type: none"> Lowest at 0V Increases with Voltage at CFG2 Highest at V_{DD}

*Sensitivity input CFG2 is implemented as a full-scale linear input only when the Easy Tune option is disabled. Refer to the Easy Tune option for further details.

3.4 Easy Tune

The Easy Tune option saves development time and board space by setting the button sensitivity automatically. During the run-time, the sensitivity is further adjusted based on the observed noise level, ensuring operations under changing noise environments. The Easy Tune feature is an alternative to classic sensitivity tuning (as provided via CFG2) and is intended for use on regular buttons for a predefined sensor size and overlay thickness. Refer to [Section 3.4.1 - CFG2 Configuration with Easy Tune Enabled](#) for further details.

Table 3-7.

Input on Easy Tune Pin	Feature
0V	Easy Tune feature is enabled
V_{DD}	Easy Tune feature is disabled

The Easy Tune feature controls the sensitivity and oversampling settings. Easy Tune applies the settings required to satisfy the basic touch tuning recommendation as provided in the [Guide to Tuning Touch Sensors](#). With increased sensitivity, increasing the oversampling is recommended to maintain noise robustness. If the user doesn't change the oversampling accordingly, Easy Tune automatically adjusts to the recommended settings for robust operation. Either the minimum amount of recommended oversampling is applied or, if higher, select the user setting according to CFG2.

Consequently, the number of components is reduced by connecting CFG1 to 0V if enabling Easy Tune. Refer to [Section 3.4.2 - CFG1 Configuration with Easy Tune Enabled](#) for further details.

3.4.1 CFG2 Configuration with Easy Tune Enabled

When Easy Tune is enabled, the CFG2 and CFG1 configurations are re-mapped to avoid the necessity for resistor dividers (reducing BOM and required board space). Table 3-8 provides the recommended configuration for sensor size and overlay thicknesses.

Table 3-8.

Type	Button Size	Overlay Thickness	CFG2	CFG1
Standard Button Type A	10~12 mm diameter	1~2 mm	0	0
Standard Button Type B	10~12 mm diameter	2~4 mm	V _{DD}	0

The Easy Tune feature can be adjusted, if needed (e.g., for usage outside the standard button sizes or other overlay thicknesses). The user may change the CFG2 and CFG1 configuration to adjust the sensitivity and oversampling.

Table 3-9.

CFG2 Configuration*	Sensitivity
0	As per recommended sensor configuration
0-191	Linear Increase in sensitivity
192-250	Invalid Range
251~255	As per recommended sensor configuration

*Sensitivity value varies linearly from 0 to 255 based on the voltage applied on the CFG2 pin - 0 corresponds to GND and 255 corresponds to V_{DD}.

When the Easy Tune feature is enabled, the thresholds are adjusted automatically based on the noise level on the touch sensors. Easy Tune comes with two standard settings (accessible by connecting CFG2 to either GND or V_{DD}) which enable the out-of-the-box Easy Tune usage for buttons of regular size and overlay thickness (see Table 3-8).

If needed, the range of variation on Easy Tune can be controlled using the CFG2 option. The variation in threshold is adjusted based on noise ranging $\pm 50\%$ of the threshold configured using the CFG2 option.

For instance, if the CFG2 option sets the threshold to 50, the touch delta on the given sensor will be nearly 100 counts. For this configuration, the Easy Tune feature can vary the threshold run-time between 25 and 75. Under no noise, the threshold value is set to 25. As noise levels increase, the Easy Tune feature increases the threshold in steps of ten counts for a maximum value of 75. As noise levels recede, the threshold values are reduced in five count steps.

Use the CFG2 setting to scale touch delta, if needed. The Easy Tune maximum and minimum threshold levels must be around 75% and 25% levels of observed touch delta.

3.4.2 CFG1 Configuration with Easy Tune Enabled

Table 3-10 shows the minimum recommended oversampling value when the Easy Tune option is enabled.

Table 3-10.

CFG2 Configuration *	Description	Minimum Recommended Oversampling
0	Standard Button Type A	16
64-127	Adjusted Easy Tune	32
128-191	Adjusted Easy Tune	64
192-250	Invalid	Invalid
255	Standard Button Type B	32

*Sensitivity value varies linearly from 0 to 255 based on the voltage applied on the CFG2 pin – 0 corresponds to GND and 255 corresponds to V_{DD} .

With Easy Tune enabled:

- If the user-configured CFG1 value is greater than or equal to the minimum recommended value, then the user configured value will be used.
- If the user configured CFG1 value is less than the minimum recommended value oversampling, then the user configuration will be overwritten and the recommended minimum oversampling is used.

As the recommended minimum oversampling is applied automatically, Easy Tune removes the need to select oversampling. Connecting CFG1 to GND is sufficient to ensure operation, removing the need for a resistor ladder and reducing BOM and board space. Connecting CFG1 to a pin other than GND enables the user to enforce an oversampling higher than recommended (see Table 3-11).

Table 3-11.

CFG1 Configuration	Minimum Recommended Oversampling
A	Minimum recommended oversampling will be automatically applied
B	Always x64 oversampling will be applied
C	Minimum recommended or x32 oversampling will be applied, whichever is higher
D	Minimum recommended or x16 oversampling will be applied, whichever is higher

For example, if CFG2 is configured to V_{DD} (2–4 mm overlay above a 10–12 mm diameter button), then the recommended oversampling value is 32. A resistor ladder is needed to set x32 oversampling on CFG1. With Easy Tune enabled, the MTCH1060 will follow that guidance automatically so that CFG1 can be connected to GND. The MTCH1060 will use the recommended minimum oversampling of 32.

3.5 Single-Button Mode

In Single-Button mode, the MTCH1060 touch controller will focus operation on Button0. Single-Button mode reduces power consumption as only Button0 will be scanned. The exemplary use case is a power button on a device: Only the power button will turn the device on. When the device is turned on, all buttons must be active and scanned. The Single-Button mode feature can be enabled or disabled during run-time. Five seconds after enabling, Single-Button mode feature is activated.

After enabling Single-Button mode, a 5s timeout period starts. If no button is activated during this 5s, Single-Button mode is entered. After entering Single-Button mode, all buttons, except Button0, will be suspended from touch measurement. Button0 will be the only button scanned for touch. When touch is detected on Button0, the suspended sensors instantly resume and calibrate, and touch measurements are performed on all enabled sensors. Single-Button mode must be disabled by the host within 5s so all the buttons remain active. If the host doesn't disable Single-Button mode, it will be re-entered after 5s of a no touch event.

While in Single-Button mode, the host may switch to regular, all buttons enabled, scan mode at any time with immediate effect.

Single-Button mode can be used as a power button to unlock other keys or as a proximity trigger to detect an approaching finger toward the panel to activate the touch-sensor panel.

Table 3-12.

Input	Feature
0V	Single-Button mode feature is enabled
V _{DD}	Single-Button mode feature is disabled

3.6 Touch Tune Data

The MTCH1060 touch controller can visualize the touch data of the sensors. This reduces development time and enables judging performance beyond the simple yes/no of reported touch states. Using the Tune Data feature during the development stage is recommended. Refer to the [Appendix](#) for information on how to enable this feature.

Note: Disabling or enabling in run-time is not possible.

Table 3-13.

Input	Feature
0V	Tune Data feature is enabled. The touch detect state is NOT output on any of the OUTx pins. UART data will be available on the OUT2 pin. <ul style="list-style-type: none"> • Transmission Bits: 8-bit • Start bit: 1 • Stop bit: 1 • Baud rate: 38400 • Polarity: None
V _{DD}	The Tune Data feature is disabled. The touch detect state is indicated using OUTx pins.

3.7 Power-up and Run-Time Configuration Summary

[Table 3-14](#) summarizes whether a particular option is run-time configurable.

Table 3-14.

Configuration	Power-up or Run-Time
Sensor enable or disable	Power-up only
Single-Button mode enabled or disabled	Both power-up and run-time
Easy Tune	Power-up only
CFGx	Both power-up and run-time Note: During Single-Button mode, if any sensor is in detect, CFGx pins are not read and configurations are not updated.
Tune Data	Power-up only

3.8 Further Preset Configurations

Additional touch parameters are set to provide reliable and consistent operation in several applications. Further details on touch parameters can be found in the [QTouch® Modular Library Peripheral Touch Controller User's Guide](#). The following section covers the preset settings of the MTCH1060 touch controller.

3.8.1 Touch Detection

Table 3-15.

Setting	Value	Description
Detect Hysteresis	12.5%	Touch will be reported as released after the signal falls 12.5% below the sensitivity setting.
Detect Count-In	4	<p>Touch is reported after confirmation scans validate touch four times in a row. These confirmation scans are executed right after user touch detection.</p> <p>This suppresses any possible detections generated by electrical noise or quick brushes of an object and fosters robust touch operation.</p> <p>Note: During confirmation scans, only the sensors which go into detect are measured.</p> <p>The response time varies based on the number of sensors simultaneously touched. Refer to Section 6 - Example Circuit for further details.</p>

3.8.2 Anti-Touch Recalibration

Anti-touch recalibration always provides the intended touch sensitivity.

An anti-touch occurs if a button is pressed longer than the maximum ON duration at the moment of release. Anti-touch recalibration ensures that the button is capable of detecting the following touch.

Note: During the anti-touch recalibration, confirmation scans are performed only for the required sensor.

3.8.3 Maximum on Duration

Table 3-16.

Setting	Value	Description
Maximum on Duration	8s	<p>The button will be recalibrated, and the touch will not be reported on the respective OUT pin when the user touches the button for more than eight seconds. The button will be recalibrated once again if the user removes the touch. Subsequent user touches will be reported on the OUT pin.</p> <p>Touch may not be detected during an anti-touch recalibration. The maximum time required to perform recalibration is three times the measurement period. If the measurement period is back-to-back, three times the measurement time * the number of sensors enabled + measurement time * the number of sensors in recalibration * 14. If the user tries to touch/tap the sensor during recalibration, the recalibration time might be longer.</p>

3.8.4 Sensor Drift

The MTCH1060 touch controller provides robust touch sensing under electrical noise. Because touch raw data signals will drift over time, the drift must be compensated. Otherwise, false detections, non-detections and sensitivity shifts over environmental changes may occur.

Drift compensation is performed on the MTCH1060 and no host intervention is needed to compensate for environmental changes.

Figure 3-1.

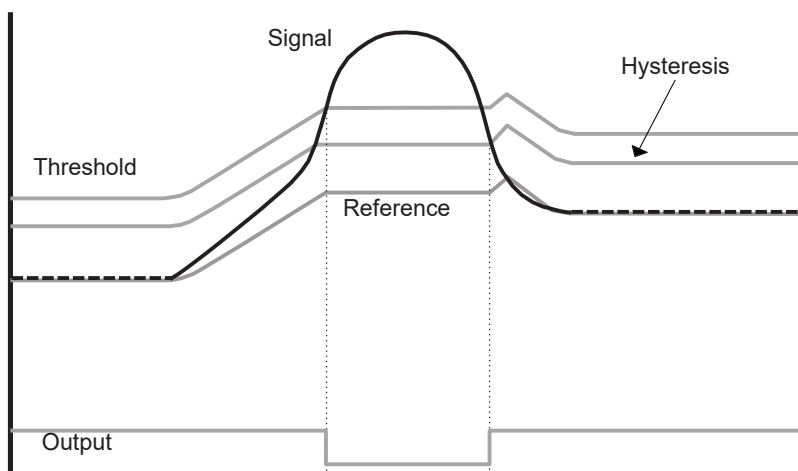

3.8.5 Frequency Hopping with Auto-Tune

The MTCH1060 touch controller provides robust touch sensing under electrical noise. Active noise avoidance technologies, such as frequency hopping with auto-tune, are embedded. As a result, the MTCH1060 proactively adapts the touch sensing frequency according to the noise scenario during run-time. No host intervention is needed.

Table 3-17. Recommended Configuration

CI Noise Level	External Resistor on Sense Lines	V _{DD}
Up to 6V	100 kΩ	Between 3.3V and 5V
Up to 10V	100 kΩ	5V

4. Touch Sensor

4.1 BUTTONx (Touch Electrodes)

BUTTONx are the touch sensor input pins that are connected to the sensor electrodes via a series resistor to reduce the EMI and EMC. The series resistor can be from 1 k Ω to 100 k Ω , depending on the sensor capacitance and desired level of EMC performance. Refer to Microchip Application Note (AN2934) - [Capacitive Touch Sensor Design](#) for further details.

With the exception of BUTTON0, all other buttons can be disabled by connecting the corresponding BUTTONx pin to V_{DD} . The MTCH1060 touch controller can be configured to perform touch measurements for fewer buttons using this option, thus improving the response time and power consumption for the designs that require only a subset number of sensors.

4.2 SHIELD (Driven Shield)

The MTCH1060 touch controller features an active shield (Driven Shield +) signal to enhance touch sensitivity and robustness.

Driven Shield Plus benefits:

- Reduced sensor load
- Water-tolerant touch
- Increased sensitivity
- Shields against electrical noise. The sensors not currently measured are driven as a shield, helping to avoid false detection due to the water bridge between the multiple sensors.

Refer to Microchip Application Note (AN2934) - [Capacitive Touch Sensor Design](#) for further details and layout considerations for Driven Shield Plus usage.

5. Touch Output

5.1 OUTx

OUTx indicates the touch detection state of BUTTONx, an open-drain output requiring an external pull-up to V_{DD} . The pin is in a high-impedance state, while the touch sensor is not in detect, switching to output-low when the sensor is touched.

Note: When Touch Tune Data is enabled, touch output is unavailable on any OUTx pin.

6. Example Circuit

Figure 6-1.

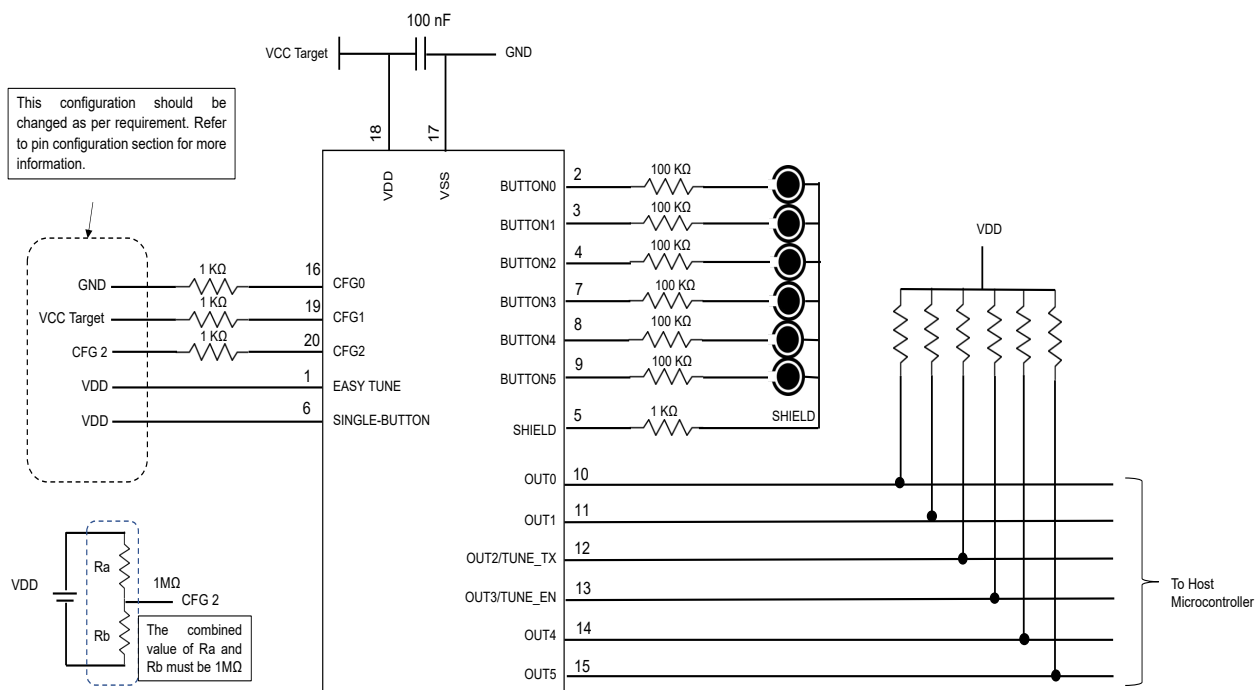

The circuit shown above is an example circuit with the following configurations:

- **CFG0** is connected to GND, setting the response time to its most prolonged duration of 250 ms
- **CFG1** is connected to V_{CC} , setting the number of samples at 16
- **CFG2** is connected to the potentiometer, where the sensitivity is configurable

7. Response Time

Figure 7-1. Timing Diagram

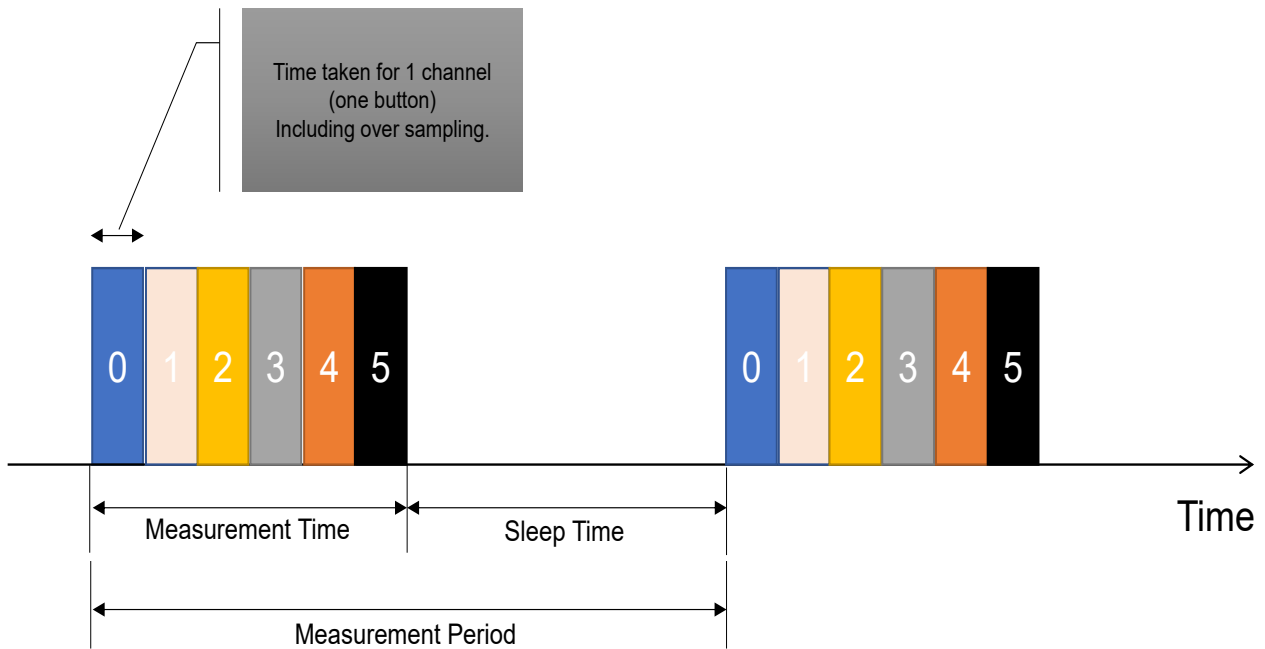

7.1 Confirmation Scan

Additional scans are performed to confirm a finger touch or finger removal. To avoid false touch triggers, the MTCH1060 touch controller performs further scans to verify whether a finger is touching the sensor or if touch is released. These confirmation scans are done back-to-back to improve response time. Only sensors that need confirmation scans are measured back-to-back. If the user touches only one sensor, then confirmation scans are done only to that sensor. If the user touches two sensors simultaneously, the confirmation scans are done for two sensors.

Figures 7-2 and 7-3 show how to perform confirmation scans for single and multiple channels, respectively.

Figure 7-2. Confirmation Scan for Single Channel

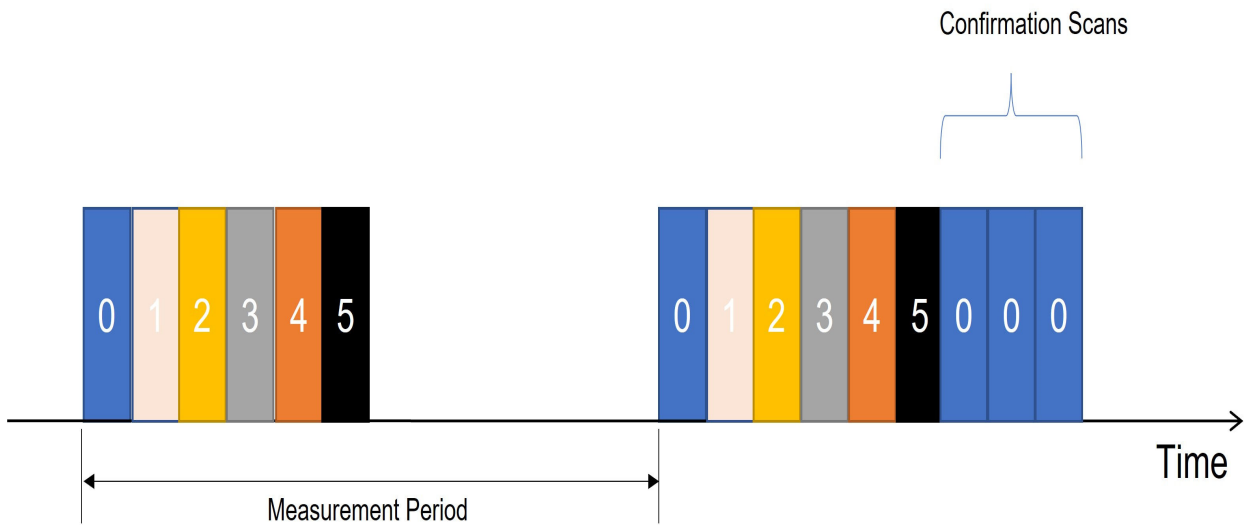
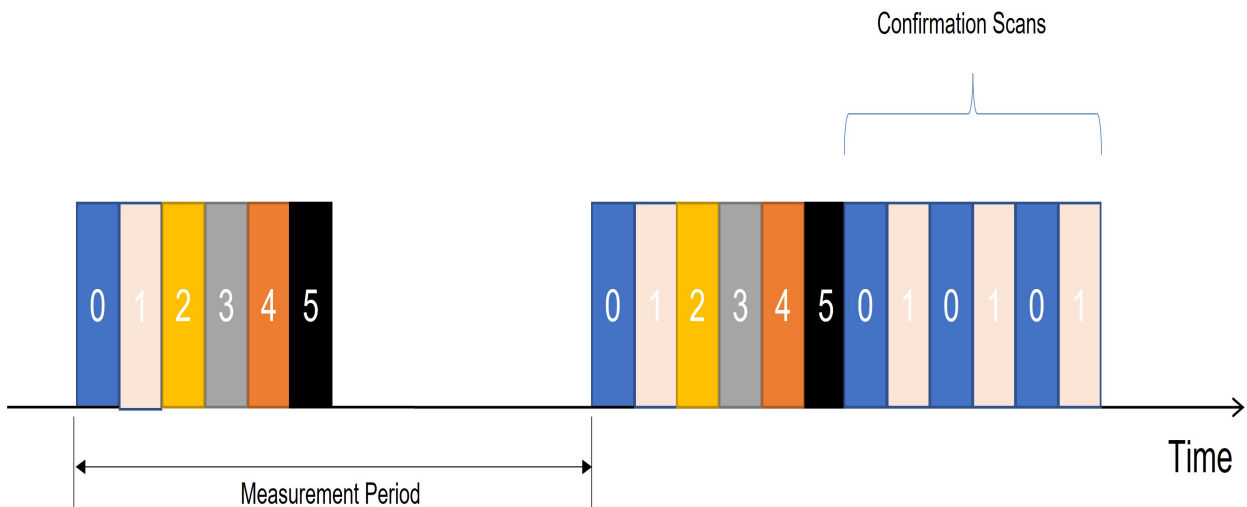

Figure 7-3. Confirmation Scan for Multiple Channels



7.2 Formula to Calculate Response Time

The formula in Table 7-1 is used to calculate response time:

Table 7-1.

(CFG0 ≠ B):	$(2 \times \text{Measurement period}) + (1 \times \text{Measurement time} \times \text{Total number of sensors enabled}) + (3 \times \text{Measurement time} \times \text{Total number of sensors touched})$
Free-running measurements (CFG0 = B):	$(3 \times \text{Measurement time} \times \text{Total number of sensors enabled}) + (3 \times \text{Measurement time} \times \text{Total number of sensors touched})$

For oversampling, measurement time is provided in Table 7-2. Due to frequency hopping, measurement time varies based on noise level. The data captured in this table show the maximum measurement time.

Table 7-2.

Number of Samples (CFG1)	Maximum Measurement Time
8	0.8 ms
16	1.5 ms
32	2.9 ms
64	5.7 ms

Example calculation #1:

- Oversample: 8
- Measurement Period: 50 ms
- Number of sensors enabled: 6
- Number of sensors touched: 2
- Response Time = $2 * 50 + 1 * 0.8 * 6 + 3 * 0.8 * 2 = 110$ ms

Example calculation #2:

- Oversample: 32
- Measurement Period: 50 ms
- Number of sensors enabled: 4
- Number of sensors touched: 2
- Response Time = $2 * 50 + 1 * 2.9 * 4 + 3 * 2.9 * 2 = 129$ ms

7.3 Worst-Case and Best-Case Response Time

Figure 7-4. Worst-Case Response Time Depiction

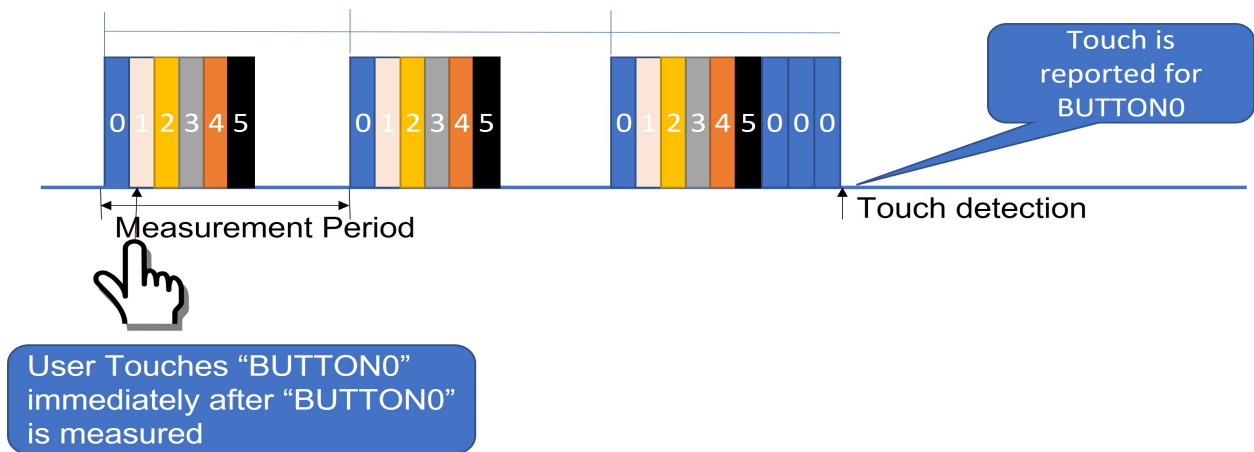
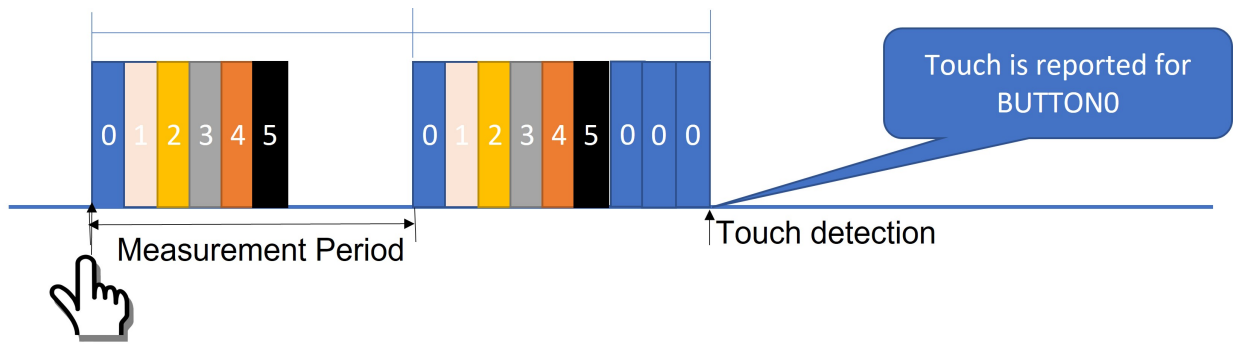

Figure 7-5. Best-Case Response Time Depiction



User Touches "BUTTON0" just before starting the measurement

7.4 Worst-Case Response Time (ms)

The worst-case response time is calculated when the sensor is touched after its measurement, as shown in Figure 7-4. The response times obtained are provided in the following tables.

When one sensor is touched:

Measurement period (ms)	Response Time			
	CFG1 x8 oversampling	CFG1 x16 oversampling	CFG1 x32 oversampling	CFG1 x64 oversampling
Free run	16	31	60	119
50	107	113	126	151
100	207	213	226	251
250	507	513	526	551

When two sensors are touched:

Measurement period (ms)	Response Time			
	CFG1 x8 oversampling	CFG1 x16 oversampling	CFG1 x32 oversampling	CFG1 x64 oversampling
Free run	18	35	69	136
50	109	118	134	168
100	209	218	234	268
250	509	518	534	568

When three sensors are touched:

Measurement period (ms)	Response Time			
	CFG1 x8 oversampling	CFG1 x16 oversampling	CFG1 x32 oversampling	CFG1 x64 oversampling
Free run	21	40	77	153
50	111	122	143	185
100	211	222	243	285
250	511	522	543	585

When four sensors are touched:

Measurement period (ms)	Response Time			
	CFG1 x8 oversampling	CFG1 x16 oversampling	CFG1 x32 oversampling	CFG1 x64 oversampling
Free run	23	44	86	170
50	114	126	152	202
100	214	226	252	302
250	514	526	552	602

When five sensors are touched:

Measurement period (ms)	Response Time			
	CFG1 x8 oversampling	CFG1 x16 oversampling	CFG1 x32 oversampling	CFG1 x64 oversampling
Free run	25	48	95	187
50	116	131	160	219
100	216	231	260	319
250	516	531	560	619

When six sensors are touched:

Measurement period (ms)	Response Time			
	CFG1 x8 oversampling	CFG1 x16 oversampling	CFG1 x32 oversampling	CFG1 x64 oversampling
Free run	27	53	103	204
50	118	135	169	236
100	218	235	269	336
250	518	535	569	636

The minimum and maximum values are calculated using the best- and worst-case response time formulas, respectively. These values are calculated for a condition when all three buttons are enabled and a single button is touched.

Worst case response time (Max)	$(2 \times \text{Measurement period}) + (1 \times \text{Measurement time} \times \text{Total number of sensors enabled}) + (3 \times \text{Measurement time} \times \text{Total number of sensors touched})$
Best case response time (Min)	$(1 \times \text{Measurement period}) + (1 \times \text{Measurement time} \times \text{Total number of sensors enabled}) + (3 \times \text{Measurement time} \times \text{Total number of sensors touched})$

Measurement Period	Min. / Avg. / Max. resulting response time (ms)											
	CFG1 x8 oversampling			CFG1 x16 oversampling			CFG1 x32 oversampling			CFG1 x64 oversampling		
	Min.	Avg.	Max.	Min.	Avg.	Max.	Min.	Avg.	Max.	Min.	Avg.	Max.
Free run	16			31			60			119		
50	55	81	107	109	111	113	117	121	126	133	142	151
100	105	156	207	209	211	213	217	221	226	233	242	251
250	255	381	507	509	511	513	517	521	526	533	542	551

Note: Considering the measurement times of all the frequencies, the response times calculated may have a $\pm 5 \mu\text{s}$ variation.

Figure 7-6. Response Time

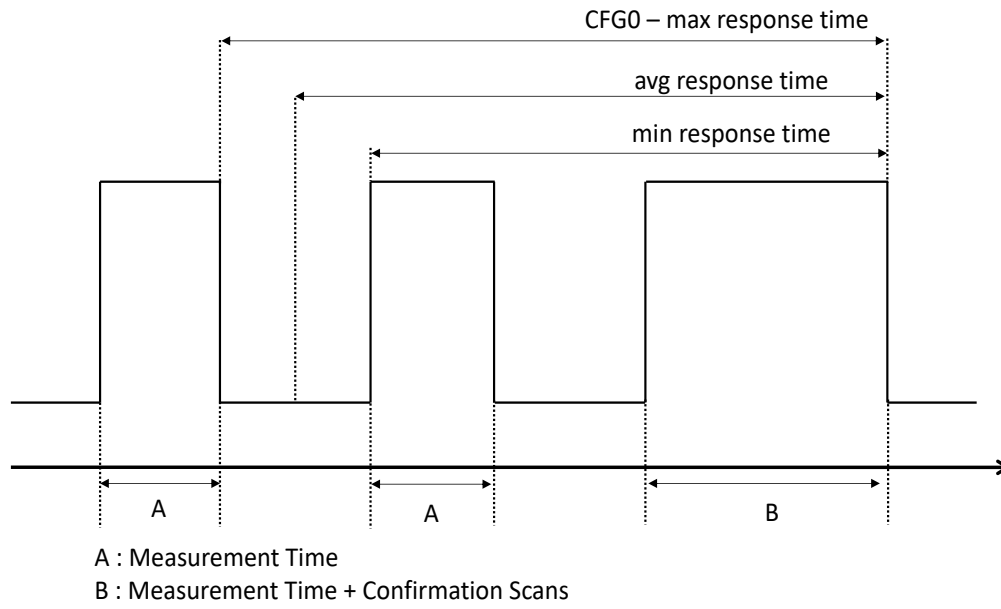

8. Power Consumption

8.1 Single-Button Mode Enabled

The following tables show power consumption of Button0 while all other buttons are suspended for both 3.3V and 5V V_{DD} . The current is in microamperes. Refer to [Section 3.5 - Single-Button Mode](#) for further details.

I_{DD} (μ A) / x8 Oversampling		
Measurement Period CFG1 (ms)	$V_{DD} = 3.3V$	$V_{DD} = 5V$
Free Run	1422	2263
50	67	91
100	47	61
250	35	41

I_{DD} (μ A) / x16 Oversampling		
Measurement Period CFG1 (ms)	$V_{DD} = 3.3V$	$V_{DD} = 5V$
Free Run	1422	2263
50	83	124
100	55	73
250	38	47

I_{DD} (μ A) / x32 Oversampling		
Measurement Period CFG1 (ms)	$V_{DD} = 3.3V$	$V_{DD} = 5V$
Free Run	1422	2263
50	113	185
100	71	97
250	45	56

I_{DD} (μ A) / x64 Oversampling		
Measurement Period CFG1 (ms)	$V_{DD} = 3.3V$	$V_{DD} = 5V$
Free Run	1422	2263
50	173	258
100	101	144
250	57	57

8.2 Single-Button Mode Disabled

The data in the following tables are taken when all the buttons (six buttons) are measured at 3.3V and 5V. The current is in microamperes.

I_{DD} (μ A) / x8 Oversampling		
Measurement Period CFG1 (ms)	$V_{DD} = 3.3V$	$V_{DD} = 5V$
Free Run	1476	2332
50	155	223
100	93	127
250	54	69

I_{DD} (μA) / x16 Oversampling		
Measurement Period CFG1 (ms)	V _{DD} = 3.3V	V _{DD} = 5V
Free Run	1476	2332
50	248	354
100	139	199
250	72	98

I_{DD} (μA) / x32 Oversampling		
Measurement Period CFG1 (ms)	V _{DD} = 3.3V	V _{DD} = 5V
Free Run	1476	2332
50	428	650
100	231	301
250	109	139

I_{DD} (μA) / x64 Oversampling		
Measurement Period CFG1 (ms)	V _{DD} = 3.3V	V _{DD} = 5V
Free Run	1476	2332
50	791	1220
100	329	640
250	138	169

9. Specification

9.1 Disclaimer

Typical values are measured at $T = 25^{\circ}\text{C}$ and $V_{\text{DD}} = 3.0\text{V}$ unless otherwise specified. All minimum and maximum values are valid across operating temperature and voltage unless otherwise specified.

9.2 Electrical Specification

Stresses beyond those listed in this section may cause permanent damage to the device. This is a stress rating only, and functional operation of the device at these or other conditions beyond those indicated in the operational sections of this specification is not implied. Exposure to absolute maximum rating conditions for extended periods may affect device reliability.

Table 9-1. Absolute Maximum Ratings

Symbol	Description	Min.	Max.	Unit
	Ambient temperature under bias	-40	+85/+125	$^{\circ}\text{C}$
TStorage	Storage temperature	-65	+150	$^{\circ}\text{C}$
VPin	Pin voltage to GND	-0.3	$V_{\text{DD}} + 0.3$	V
IPin	I/O pin sink/source current	—	± 25	mA

9.3 General Operating Ratings

The device must operate within the ratings listed in this section for all other electrical characteristics and typical characteristics of the device to be valid.

Table 9-2. General Operating Conditions

Symbol	Description	Condition	Min.	Max.	Unit
V_{DD}	Operation supply voltage	—	2	5.5	V
—	Supply ripple noise	—	—	20	mV p-p
SV _{DD}	V_{DD} rise rate	—	0.05	—	V/ms
T	Operating temperature range ⁽¹⁾	Standard temperature range	-40	85	$^{\circ}\text{C}$
		Extended temperature range	-40	125	$^{\circ}\text{C}$

Note: Refer to the device ordering codes for the device temperature range.

9.4 I/O Pin Characteristics

Table 9-3. I/O Pin Characteristics ($T_A = 25^\circ\text{C}$, $V_{DD} = 3.0\text{V}$ Unless Otherwise Stated)

Symbol	Description	Condition	Min.	Typ.	Max.	Unit
V_{OL}	I/O pin drive strength	$I_{OL} = 10\text{ mA}$, $V_{DD} = 3.0\text{V}$	—	—	0.6	V
V_{OH}	I/O pin drive strength	$I_{OH} = 6\text{ mA}$, $V_{DD} = 3.0\text{V}$	$V_{DD}-0.7$	—	—	V
V_{IL}	With Schmitt Trigger Buffer	$1.8\text{V} \leq V_{DD} \leq 5.5\text{V}$	—	—	$0.2 V_{DD}$	V
	MCLR	—	—	—	$0.2 V_{DD}$	V
V_{IH}	With Schmitt Trigger Buffer	$1.8\text{V} \leq V_{DD} \leq 5.5\text{V}$	$0.8 V_{DD}$	—	—	V
	MCLR	—	$0.8 V_{DD}$	—	—	V
I_{IL}	I/O Ports	$V_{SS} \leq V_{PIN} \leq V_{DD}$ Pin at high-impedance, 85°C $V_{SS} \leq V_{PIN} \leq V_{DD}$ Pin at high-impedance, 125°C	—	± 5 ± 5	± 125 ± 1000	V
	MCLR	$V_{SS} \leq V_{PIN} \leq V_{DD}$ Pin at high-impedance, 85°C	—	± 50	± 200	V

Table 9-4. Sensor Capacitance

Symbol	Description	Condition	Min.	Typ.	Max.	Unit
C_X	Sensor electrode capacitance	—	1	—	15	pF

10. Package Marking

10.1 Package Marking

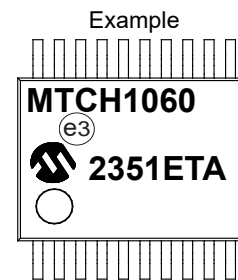
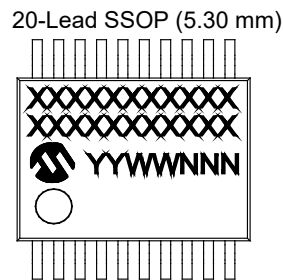
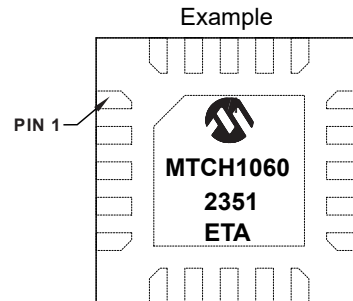
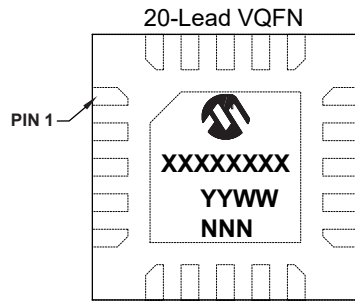

Rev. 30-00000A
5/17/2017

Legend:	XX...X	Customer-specific information or Microchip part number
	Y	Year code (last digit of calendar year)
	YY	Year code (last 2 digits of calendar year)
	WW	Week code (week of January 1 is week '01')
	NNN	Alphanumeric traceability code
	(e3)	Pb-free JEDEC [®] designator for Matte Tin (Sn)
	*	This package is Pb-free. The Pb-free JEDEC designator ((e3)) can be found on the outer packaging for this package.

Note: In the event the full Microchip part number cannot be marked on one line, it will be carried over to the next line, thus limiting the number of available characters for customer-specific information.

11. Package Drawing

11.1 20-Pin VQFN

20-Lead Very Thin Plastic Quad Flat, No Lead Package (REB) - 3x3 mm Body [VQFN] With 1.7 mm Exposed Pad; Atmel Legacy Global Package Code ZCL

Note: For the most current package drawings, please see the Microchip Packaging Specification located at <http://www.microchip.com/packaging>

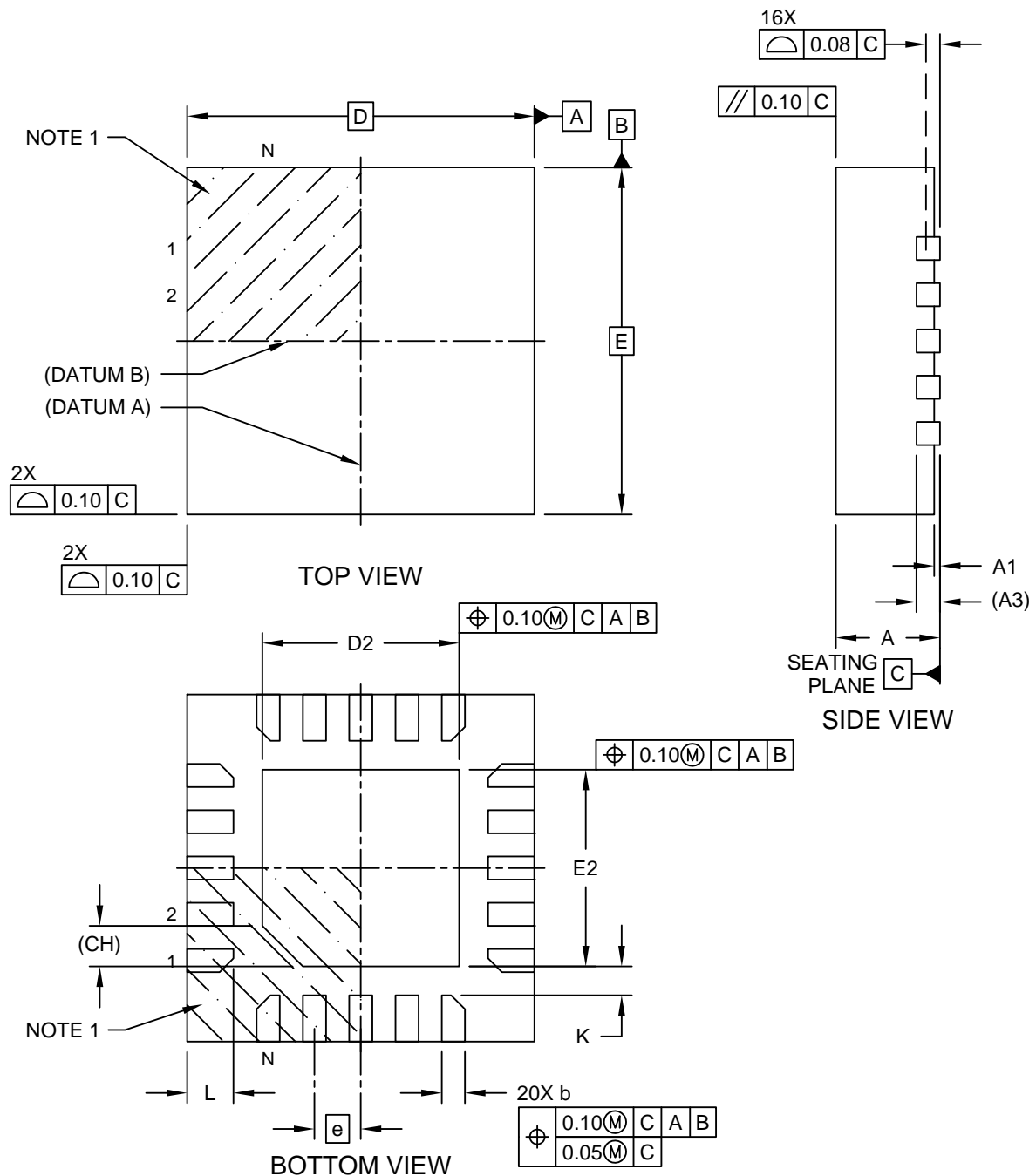

Microchip Technology Drawing C04-21380 Rev A Sheet 1 of 2

**20-Lead Very Thin Plastic Quad Flat, No Lead Package (REB) - 3x3 mm Body [VQFN]
With 1.7 mm Exposed Pad; Atmel Legacy Global Package Code ZCL**

Note: For the most current package drawings, please see the Microchip Packaging Specification located at <http://www.microchip.com/packaging>

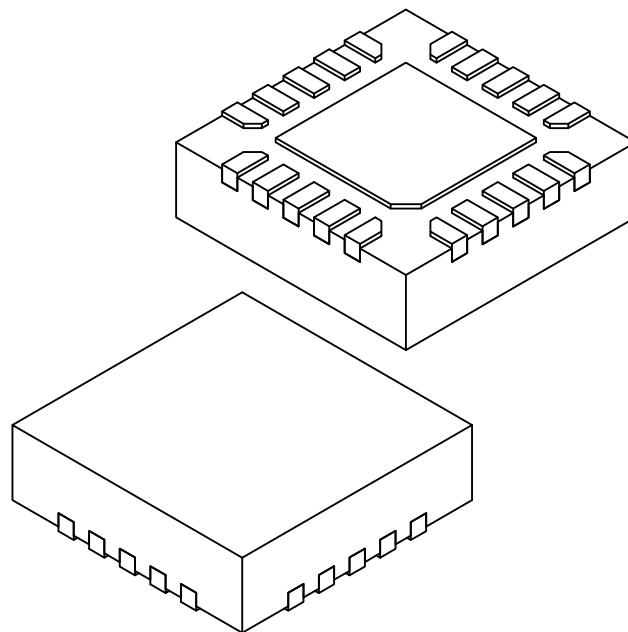

Dimension Limits	Units	MILLIMETERS		
		MIN	NOM	MAX
Number of Terminals	N	20		
Pitch	e	0.40 BSC		
Overall Height	A	0.80	0.85	0.90
Standoff	A1	0.00	0.035	0.05
Terminal Thickness	A3	0.203 REF		
Overall Length	D	3.00 BSC		
Exposed Pad Length	D2	1.60	1.70	1.80
Overall Width	E	3.00 BSC		
Exposed Pad Width	E2	1.60	1.70	1.80
Terminal Width	b	0.15	0.20	0.25
Terminal Length	L	0.35	0.40	0.45
Terminal-to-Exposed-Pad	K	0.20	-	-
Pin 1 Index Chamfer	CH	0.35 REF		

Notes:

- Pin 1 visual index feature may vary, but must be located within the hatched area.
- Package is saw singulated
- Dimensioning and tolerancing per ASME Y14.5M
BSC: Basic Dimension. Theoretically exact value shown without tolerances.
REF: Reference Dimension, usually without tolerance, for information purposes only.

Microchip Technology Drawing C04-21380 Rev A Sheet 2 of 2

**20-Lead Very Thin Plastic Quad Flat, No Lead Package (REB) - 3x3 mm Body [VQFN]
With 1.7 mm Exposed Pad; Atmel Legacy Global Package Code ZCL**

Note: For the most current package drawings, please see the Microchip Packaging Specification located at <http://www.microchip.com/packaging>

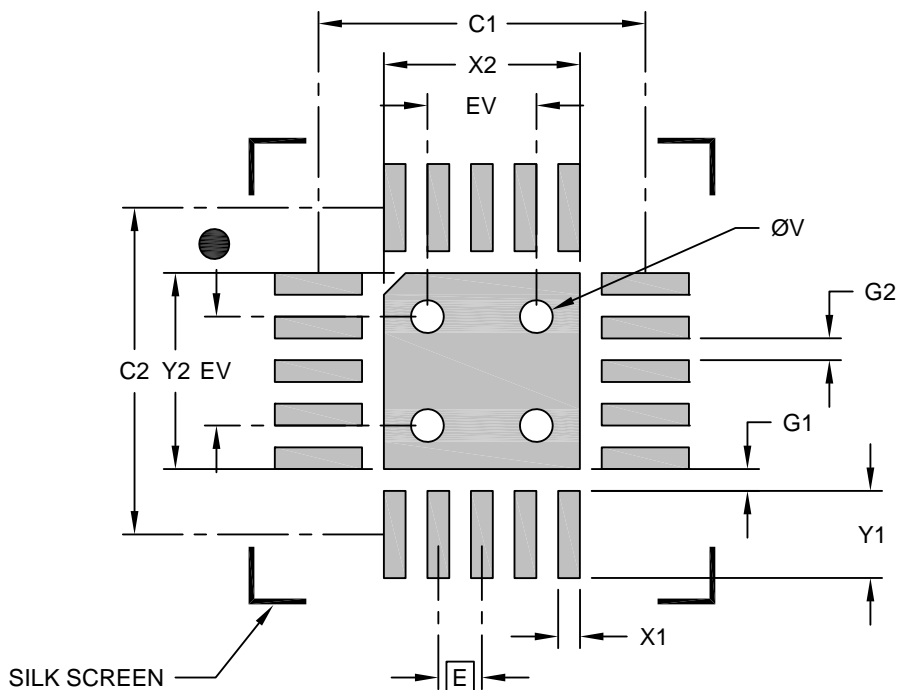

RECOMMENDED LAND PATTERN

Dimension Limits	Units	MILLIMETERS		
		MIN	NOM	MAX
Contact Pitch	E	0.40 BSC		
Optional Center Pad Width	X2			1.80
Optional Center Pad Length	Y2			1.80
Contact Pad Spacing	C1		3.00	
Contact Pad Spacing	C2		3.00	
Contact Pad Width (X20)	X1			0.20
Contact Pad Length (X20)	Y1			0.80
Contact Pad to Center Pad (X20)	G1	0.20		
Contact Pad to Contact Pad (X16)	G2	0.20		
Thermal Via Diameter	V		0.30	
Thermal Via Pitch	EV		1.00	

Notes:

1. Dimensioning and tolerancing per ASME Y14.5M
BSC: Basic Dimension. Theoretically exact value shown without tolerances.
2. For best soldering results, thermal vias, if used, should be filled or tented to avoid solder loss during reflow process

Microchip Technology Drawing C04-23380 Rev A

11.2 20-Pin SSOP

20-Lead Plastic Shrink Small Outline (SS) - 5.30 mm Body [SSOP]

Note: For the most current package drawings, please see the Microchip Packaging Specification located at <http://www.microchip.com/packaging>

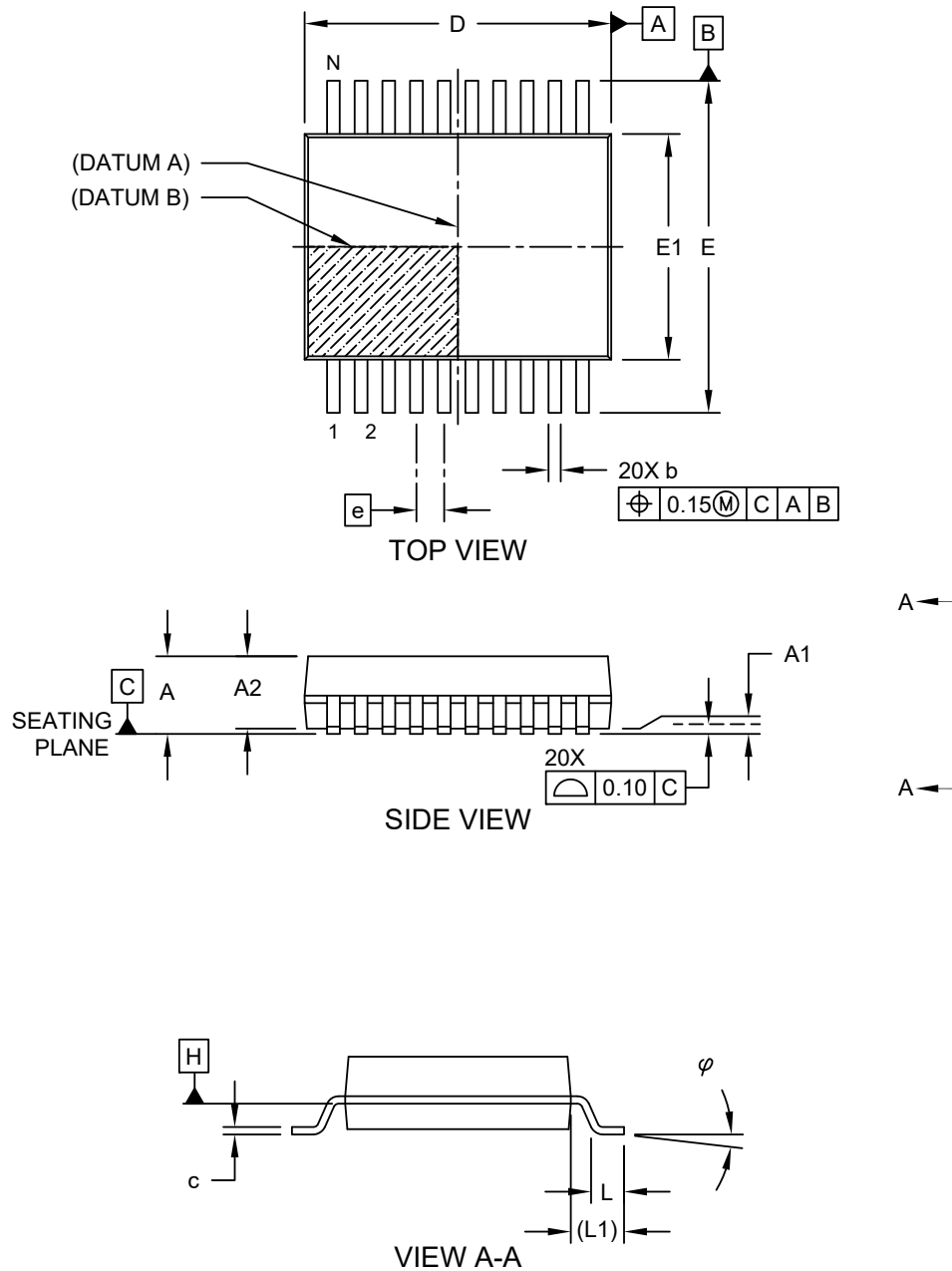

Microchip Technology Drawing C04-072 Rev C Sheet 1 of 2

20-Lead Plastic Shrink Small Outline (SS) - 5.30 mm Body [SSOP]

Note: For the most current package drawings, please see the Microchip Packaging Specification located at <http://www.microchip.com/packaging>

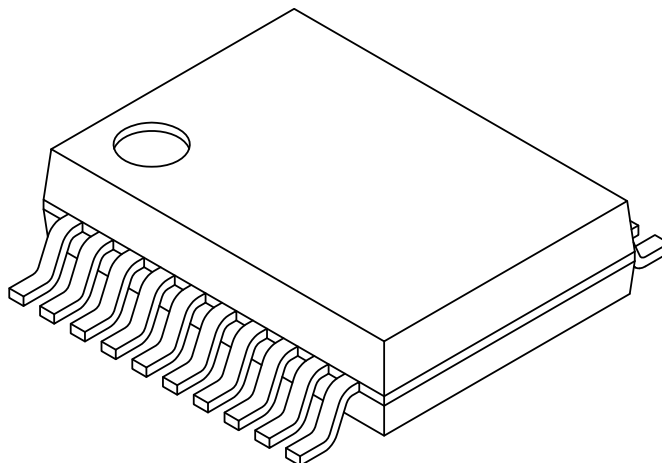

Dimension Limits	Units	MILLIMETERS		
		MIN	NOM	MAX
Number of Pins	N	20		
Pitch	e	0.65 BSC		
Overall Height	A	-	-	2.00
Molded Package Thickness	A2	1.65	1.75	1.85
Standoff	A1	0.05	-	-
Overall Width	E	7.40	7.80	8.20
Molded Package Width	E1	5.00	5.30	5.60
Overall Length	D	6.90	7.20	7.50
Foot Length	L	0.55	0.75	0.95
Footprint	L1	1.25 REF		
Lead Thickness	c	0.09	-	0.25
Foot Angle	φ	0°	4°	8°
Lead Width	b	0.22	-	0.38

Notes:

- Pin 1 visual index feature may vary, but must be located within the hatched area.
- Dimensions D and E1 do not include mold flash or protrusions. Mold flash or protrusions shall not exceed 0.20mm per side.
- Dimensioning and tolerancing per ASME Y14.5M

BSC: Basic Dimension. Theoretically exact value shown without tolerances.

REF: Reference Dimension, usually without tolerance, for information purposes only.

Microchip Technology Drawing C04-072 Rev C Sheet 2 of 2

20-Lead Plastic Shrink Small Outline (SS) - 5.30 mm Body [SSOP]

Note: For the most current package drawings, please see the Microchip Packaging Specification located at <http://www.microchip.com/packaging>

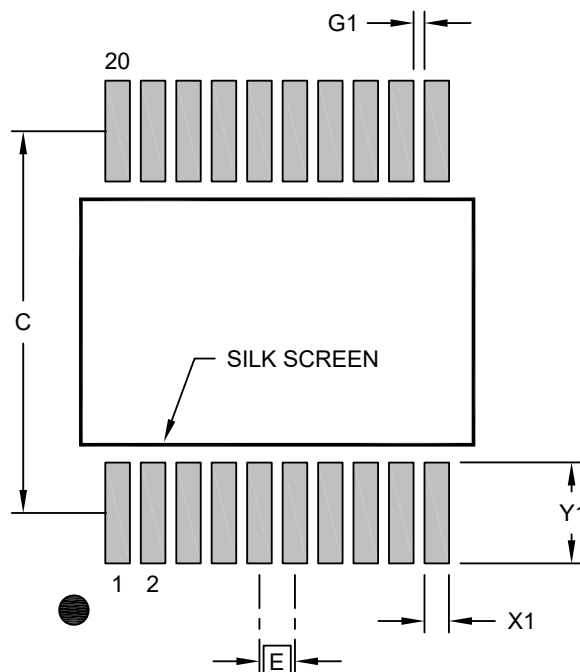

RECOMMENDED LAND PATTERN

Dimension Limits	Units	MILLIMETERS		
		MIN	NOM	MAX
Contact Pitch	E	0.65 BSC		
Contact Pad Spacing	C		7.00	
Contact Pad Width (X20)	X1			0.45
Contact Pad Length (X20)	Y1			1.85
Contact Pad to Center Pad (X18)	G1	0.20		

Notes:

- Dimensioning and tolerancing per ASME Y14.5M
BSC: Basic Dimension. Theoretically exact value shown without tolerances.
- For best soldering results, thermal vias, if used, should be filled or tented to avoid solder loss during reflow process

Microchip Technology Drawing C04-2072 Rev C

12. Appendix

12.1 Static Input Voltages

These methods will configure the MTCH1060 and provide a fixed behavior at power-up and run-time.

12.1.1 Resistor Ladder

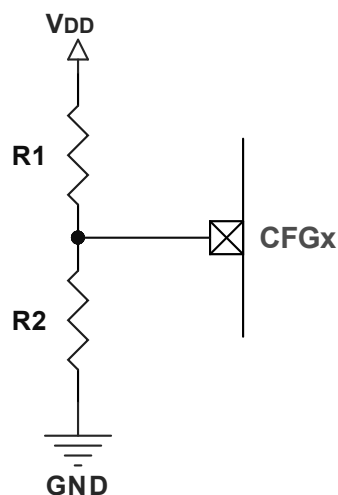

Note: It is recommended that R1 and R2 be greater than 100 k Ω for lower power consumption.

12.1.2 Direct Connect to V_{DD} or GND

Use a series resistor if a setting is set by connecting a CFGx pin to V_{DD} or GND.

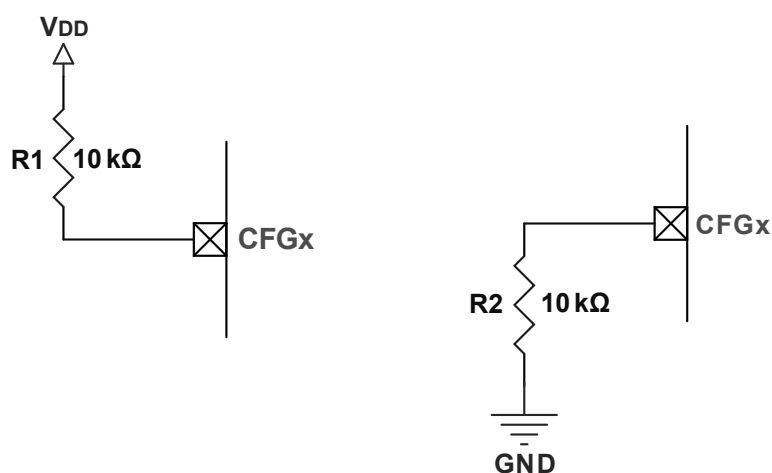

The pull-up/pull-down resistor is a pre-cautionary recommendation, as MTCH1060 will pull the CFGx neither to the V_{DD} nor to the GND during the operation.

12.2 Dynamic Input Voltages

These methods enable flexible settings during run-time or development. They are controlled by the human developer or the host IC.

12.2.1 Potentiometer

A useable method during development. This method is also used on the MTCH1060 DevKit.

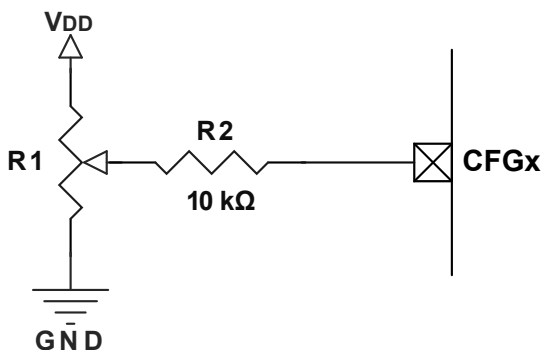

12.2.2 DAC Controlled by Host

This method is recommended if settings will dynamically change during run-time.

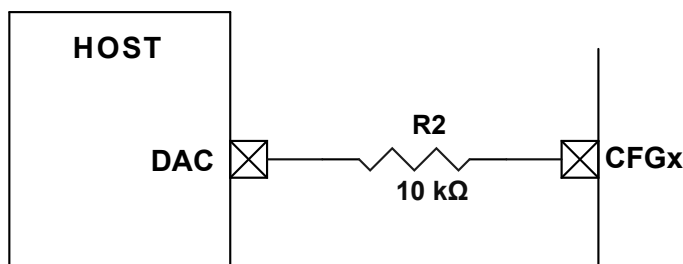

12.2.3 PWM Controlled by Host

This method is recommended if settings will dynamically change during run-time.

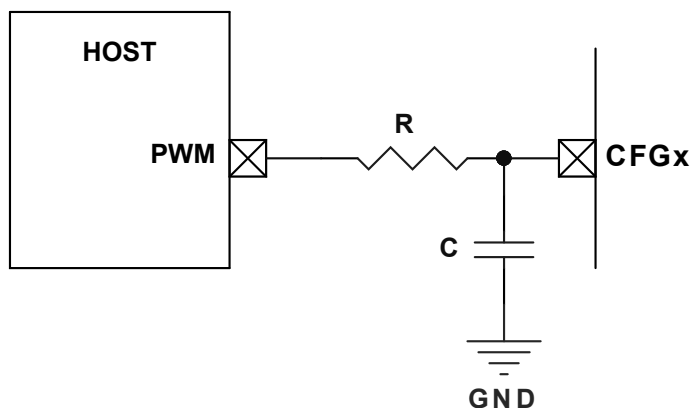

Note: Refer to Microchip Application Note TB3250, "Using PWM to Generate Analog Output" (DS90003250), for details on choosing the appropriate values of R and C.

12.3 Procedure to Visualize Touch Tune Data

Prerequisites to Enable Touch Tune Data:

1. [MPLAB Data Visualizer](#) or MPLAB DV plug-in (if MPLABX IDE is already present) must be installed in the system.

- The UART to USB converter is required to stream the UART data from the MTCH1060 at a baud rate of 38400 to PC.
 - [Microchip Touch Bridge](#)
 - [MCP2221A Breakout Module](#)
- The configuration files required to connect to DV can be downloaded from the [MTCH1060](#) product page.

Procedure to connect DV:

- Open MPLAB Data Visualizer.
- Click on **Connections**, and click the correct **COM port**. Enter the **Baud rate** in the **COM settings** as shown in the following images.

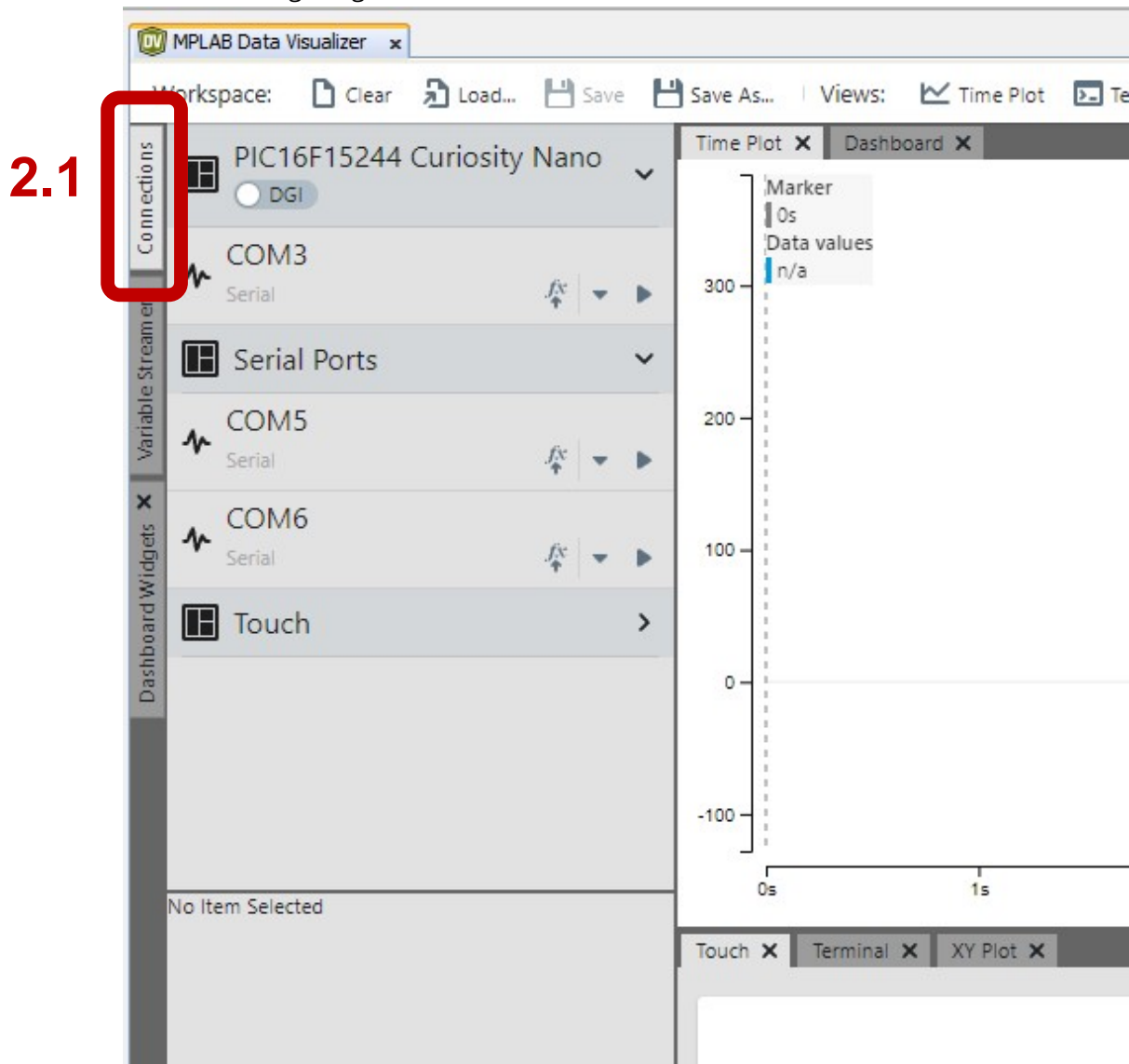

2.2

The screenshot shows the MPLAB Data Visualizer interface for a PIC16F15244 Curiosity Nano. In the 'Serial Ports' section, 'COM3' is highlighted with a red box. Below it, the 'COM3 Settings' section is visible, with the 'Baud Rate' field containing '9600' and 'Char Length' set to '8 bits'. A red arrow points from the 'COM3 Settings' section to a separate 'COM3 Settings' dialog box on the right.

2.3

The 'COM3 Settings' dialog box is shown with the 'Baud Rate' field updated to '38400'. The 'Char Length' is still set to '8 bits'.

3. Select the **Variable Streamer** tab and select the **Auto-Configure** option.

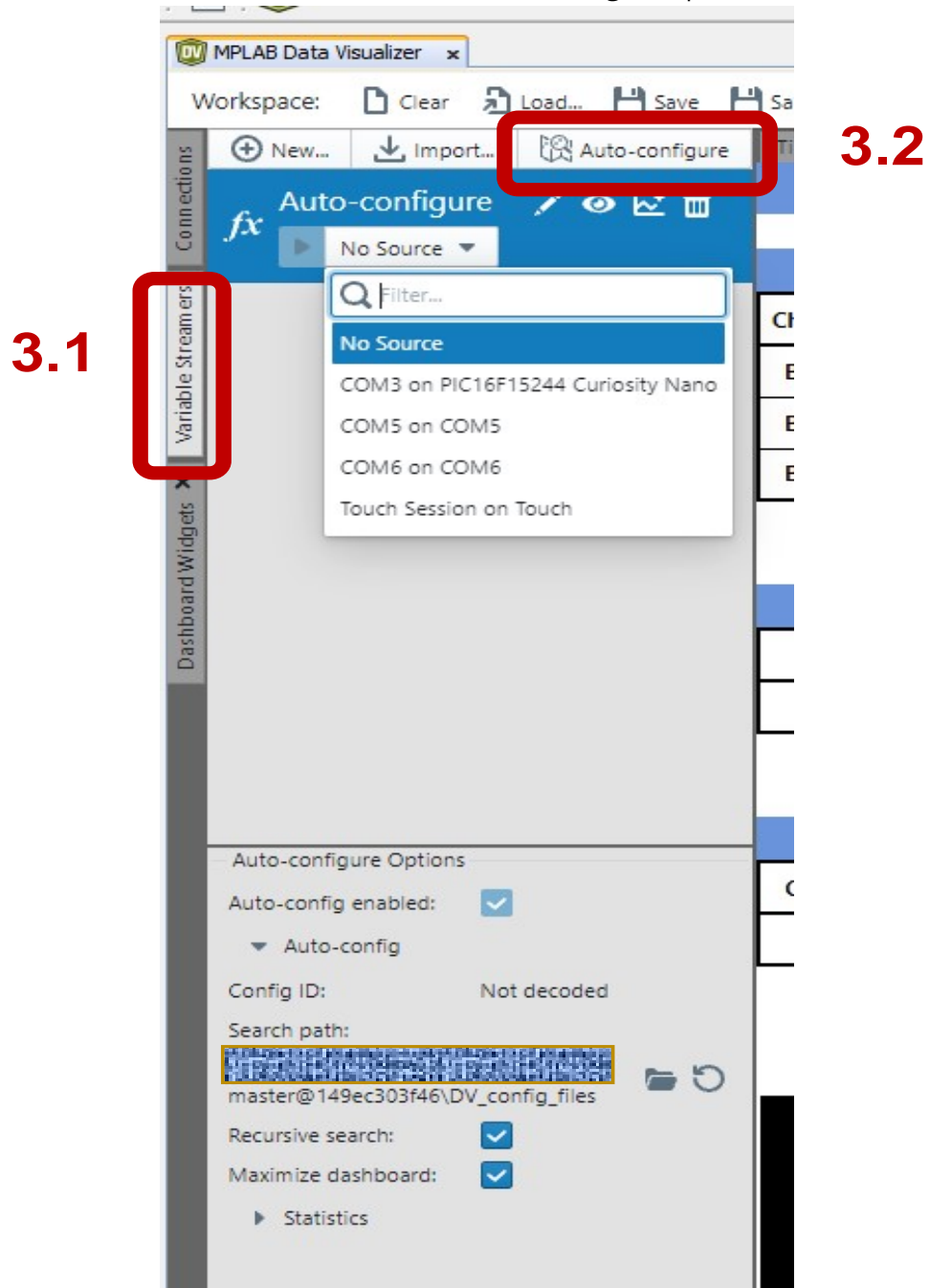

4. In the **Auto-Configure** options, select the correct folder path where the .ds files are available.

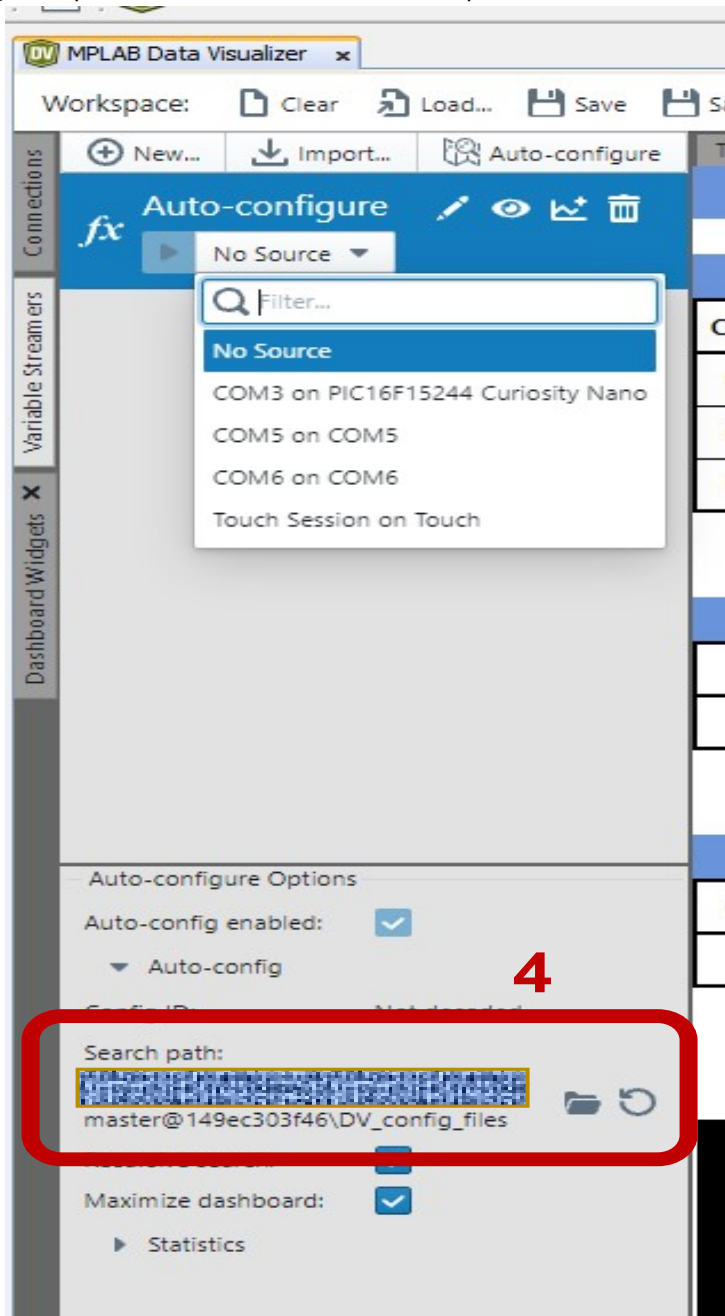

- 5. From the **Auto-Configure** drop-down, select the correct **COM port** to visualize the output.

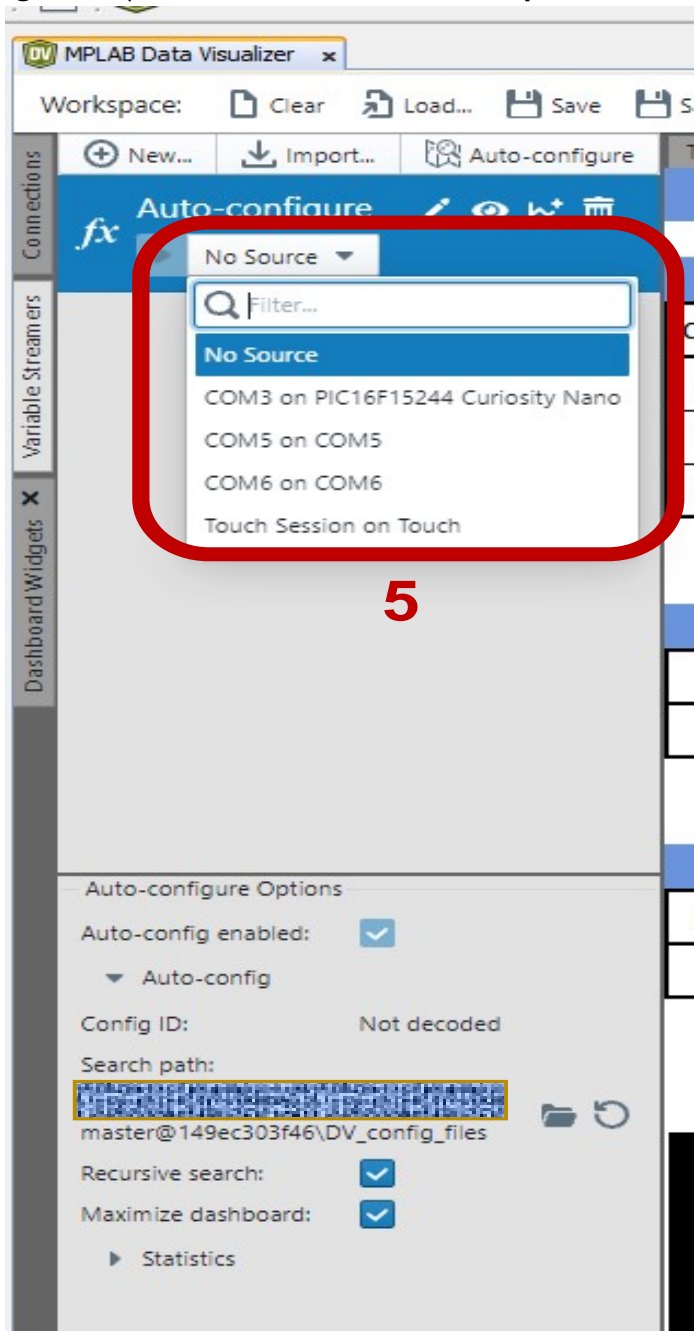

6. The MPLAB DV shows Tune Data from the MTCH1060 as shown in the following image.

The screenshot displays the MPLAB DV software interface for the MTCH1060. The main dashboard is titled "MTCH1060 TUNE DATA" and contains the following sections:

- Sensor Data:** A table with 7 columns: Channel ID, Signal, Reference, Delta, Threshold, Detect, and NoiseEnv. It lists data for six buttons.
- Configurations:** A table with 3 columns: Period, OverSamp, and Sensitivity.
- Status:** A table with 2 columns: CurrFreq and FWVersion.
- Plot:** A graph area at the bottom showing a horizontal line at approximately 15 on the y-axis.

Channel ID	Signal	Reference	Delta	Threshold	Detect	NoiseEnv
Button 0	799	800	-1	14	0	-1
Button 1	732	733	-1	14	0	0
Button 2	700	701	-1	14	0	0
Button 3	795	795	0	14	0	1
Button 4	761	761	0	14	0	1
Button 5	722	722	0	14	0	1

Period	OverSamp	Sensitivity
85	255	121

CurrFreq	FWVersion
11	16

13. Revision History

Revision	Date	Description
A	05/2023	Initial document release.

Microchip Information

The Microchip Website

Microchip provides online support via our website at www.microchip.com/. This website is used to make files and information easily available to customers. Some of the content available includes:

- **Product Support** – Data sheets and errata, application notes and sample programs, design resources, user's guides and hardware support documents, latest software releases and archived software
- **General Technical Support** – Frequently Asked Questions (FAQs), technical support requests, online discussion groups, Microchip design partner program member listing
- **Business of Microchip** – Product selector and ordering guides, latest Microchip press releases, listing of seminars and events, listings of Microchip sales offices, distributors and factory representatives

Product Change Notification Service

Microchip's product change notification service helps keep customers current on Microchip products. Subscribers will receive email notification whenever there are changes, updates, revisions or errata related to a specified product family or development tool of interest.

To register, go to www.microchip.com/pcn and follow the registration instructions.

Customer Support

Users of Microchip products can receive assistance through several channels:

- Distributor or Representative
- Local Sales Office
- Embedded Solutions Engineer (ESE)
- Technical Support

Customers should contact their distributor, representative or ESE for support. Local sales offices are also available to help customers. A listing of sales offices and locations is included in this document.

Technical support is available through the website at: www.microchip.com/support

Product Identification System

To order or obtain information, e.g., on pricing or delivery, refer to the factory or the listed sales office.

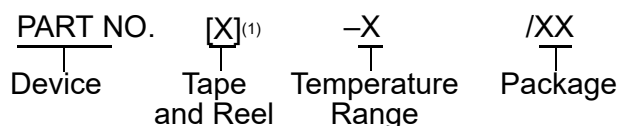

Device:	MTCH1060	
Tape & Reel Option:	Blank	= Tube
	T	= Tape & Reel
Temperature Range:	I	= -40°C to +85°C (Industrial)
	E	= -40°C to +125°C (Extended)
Package:	SS	= 20-lead SSOP
	REB	= 20-lead VQFN

Examples:

- MTCH1060 T-I/REB: Tape and Reel, Industrial temperature, 20-lead VQFN
- MTCH1060 T-E/SS: Tape and Reel Extended temperature, 20-lead SSOP

Notes:

1. Tape and Reel identifier only appears in the catalog part number description. This identifier is used for ordering purposes and is not printed on the device package. Check with your Microchip Sales Office for package availability with the Tape and Reel option.
2. Small form-factor packaging options may be available. Please check www.microchip.com/packaging for small-form factor package availability, or contact your local Sales Office.

Microchip Devices Code Protection Feature

Note the following details of the code protection feature on Microchip products:

- Microchip products meet the specifications contained in their particular Microchip Data Sheet.
- Microchip believes that its family of products is secure when used in the intended manner, within operating specifications, and under normal conditions.
- Microchip values and aggressively protects its intellectual property rights. Attempts to breach the code protection features of Microchip product is strictly prohibited and may violate the Digital Millennium Copyright Act.
- Neither Microchip nor any other semiconductor manufacturer can guarantee the security of its code. Code protection does not mean that we are guaranteeing the product is “unbreakable”. Code protection is constantly evolving. Microchip is committed to continuously improving the code protection features of our products.

Legal Notice

This publication and the information herein may be used only with Microchip products, including to design, test, and integrate Microchip products with your application. Use of this information in any other manner violates these terms. Information regarding device applications is provided only for your convenience and may be superseded by updates. It is your responsibility to ensure that your application meets with your specifications. Contact your local Microchip sales office for additional support or, obtain additional support at www.microchip.com/en-us/support/design-help/client-support-services.

THIS INFORMATION IS PROVIDED BY MICROCHIP "AS IS". MICROCHIP MAKES NO REPRESENTATIONS OR WARRANTIES OF ANY KIND WHETHER EXPRESS OR IMPLIED, WRITTEN OR ORAL, STATUTORY OR OTHERWISE, RELATED TO THE INFORMATION INCLUDING BUT NOT LIMITED TO ANY IMPLIED

WARRANTIES OF NON-INFRINGEMENT, MERCHANTABILITY, AND FITNESS FOR A PARTICULAR PURPOSE, OR WARRANTIES RELATED TO ITS CONDITION, QUALITY, OR PERFORMANCE.

IN NO EVENT WILL MICROCHIP BE LIABLE FOR ANY INDIRECT, SPECIAL, PUNITIVE, INCIDENTAL, OR CONSEQUENTIAL LOSS, DAMAGE, COST, OR EXPENSE OF ANY KIND WHATSOEVER RELATED TO THE INFORMATION OR ITS USE, HOWEVER CAUSED, EVEN IF MICROCHIP HAS BEEN ADVISED OF THE POSSIBILITY OR THE DAMAGES ARE FORESEEABLE. TO THE FULLEST EXTENT ALLOWED BY LAW, MICROCHIP'S TOTAL LIABILITY ON ALL CLAIMS IN ANY WAY RELATED TO THE INFORMATION OR ITS USE WILL NOT EXCEED THE AMOUNT OF FEES, IF ANY, THAT YOU HAVE PAID DIRECTLY TO MICROCHIP FOR THE INFORMATION.

Use of Microchip devices in life support and/or safety applications is entirely at the buyer's risk, and the buyer agrees to defend, indemnify and hold harmless Microchip from any and all damages, claims, suits, or expenses resulting from such use. No licenses are conveyed, implicitly or otherwise, under any Microchip intellectual property rights unless otherwise stated.

Trademarks

The Microchip name and logo, the Microchip logo, Adaptec, AVR, AVR logo, AVR Freaks, BesTime, BitCloud, CryptoMemory, CryptoRF, dsPIC, flexPWR, HELDO, IGLOO, JukeBlox, KeeLoq, Klear, LANCheck, LinkMD, maXStylus, maXTouch, MediaLB, megaAVR, Microsemi, Microsemi logo, MOST, MOST logo, MPLAB, OptoLyzer, PIC, picoPower, PICSTART, PIC32 logo, PolarFire, Prochip Designer, QTouch, SAM-BA, SenGenuity, SpyNIC, SST, SST Logo, SuperFlash, Symmetricom, SyncServer, Tachyon, TimeSource, tinyAVR, UNI/O, Vectron, and XMEGA are registered trademarks of Microchip Technology Incorporated in the U.S.A. and other countries.

AgileSwitch, APT, ClockWorks, The Embedded Control Solutions Company, EtherSynch, Flashtec, Hyper Speed Control, HyperLight Load, Libero, motorBench, mTouch, Powermite 3, Precision Edge, ProASIC, ProASIC Plus, ProASIC Plus logo, Quiet- Wire, SmartFusion, SyncWorld, Temux, TimeCesium, TimeHub, TimePictra, TimeProvider, TrueTime, and ZL are registered trademarks of Microchip Technology Incorporated in the U.S.A.

Adjacent Key Suppression, AKS, Analog-for-the-Digital Age, Any Capacitor, AnyIn, AnyOut, Augmented Switching, BlueSky, BodyCom, Clockstudio, CodeGuard, CryptoAuthentication, CryptoAutomotive, CryptoCompanion, CryptoController, dsPICDEM, dsPICDEM.net, Dynamic Average Matching, DAM, ECAN, Espresso T1S, EtherGREEN, GridTime, IdealBridge, In-Circuit Serial Programming, ICSP, INICnet, Intelligent Paralleling, IntelliMOS, Inter-Chip Connectivity, JitterBlocker, Knob-on-Display, KoD, maxCrypto, maxView, memBrain, Mindi, MiWi, MPASM, MPF, MPLAB Certified logo, MPLIB, MPLINK, MultiTRAK, NetDetach, Omniscient Code Generation, PICDEM, PICDEM.net, PICkit, PICtail, PowerSmart, PureSilicon, QMatrix, REAL ICE, Ripple Blocker, RTAX, RTG4, SAM-ICE, Serial Quad I/O, simpleMAP, SimpliPHY, SmartBuffer, SmartHLS, SMART-I.S., storClad, SQL, SuperSwitcher, SuperSwitcher II, Switchtec, SynchroPHY, Total Endurance, Trusted Time, TSHARC, USBCheck, VariSense, VectorBlox, VeriPHY, ViewSpan, WiperLock, XpressConnect, and ZENA are trademarks of Microchip Technology Incorporated in the U.S.A. and other countries.

SQTP is a service mark of Microchip Technology Incorporated in the U.S.A.

The Adaptec logo, Frequency on Demand, Silicon Storage Technology, and Symmcom are registered trademarks of Microchip Technology Inc. in other countries.

GestIC is a registered trademark of Microchip Technology Germany II GmbH & Co. KG, a subsidiary of Microchip Technology Inc., in other countries.

All other trademarks mentioned herein are property of their respective companies.

© 2023, Microchip Technology Incorporated and its subsidiaries. All Rights Reserved.

ISBN: 978-1-6683-2413-4

Quality Management System

For information regarding Microchip's Quality Management Systems, please visit www.microchip.com/quality.

Worldwide Sales and Service

AMERICAS	ASIA/PACIFIC	ASIA/PACIFIC	EUROPE
<p>Corporate Office 2355 West Chandler Blvd. Chandler, AZ 85224-6199 Tel: 480-792-7200 Fax: 480-792-7277 Technical Support: www.microchip.com/support Web Address: www.microchip.com</p> <p>Atlanta Duluth, GA Tel: 678-957-9614 Fax: 678-957-1455</p> <p>Austin, TX Tel: 512-257-3370</p> <p>Boston Westborough, MA Tel: 774-760-0087 Fax: 774-760-0088</p> <p>Chicago Itasca, IL Tel: 630-285-0071 Fax: 630-285-0075</p> <p>Dallas Addison, TX Tel: 972-818-7423 Fax: 972-818-2924</p> <p>Detroit Novi, MI Tel: 248-848-4000</p> <p>Houston, TX Tel: 281-894-5983</p> <p>Indianapolis Noblesville, IN Tel: 317-773-8323 Fax: 317-773-5453 Tel: 317-536-2380</p> <p>Los Angeles Mission Viejo, CA Tel: 949-462-9523 Fax: 949-462-9608 Tel: 951-273-7800</p> <p>Raleigh, NC Tel: 919-844-7510</p> <p>New York, NY Tel: 631-435-6000</p> <p>San Jose, CA Tel: 408-735-9110 Tel: 408-436-4270</p> <p>Canada - Toronto Tel: 905-695-1980 Fax: 905-695-2078</p>	<p>Australia - Sydney Tel: 61-2-9868-6733</p> <p>China - Beijing Tel: 86-10-8569-7000</p> <p>China - Chengdu Tel: 86-28-8665-5511</p> <p>China - Chongqing Tel: 86-23-8980-9588</p> <p>China - Dongguan Tel: 86-769-8702-9880</p> <p>China - Guangzhou Tel: 86-20-8755-8029</p> <p>China - Hangzhou Tel: 86-571-8792-8115</p> <p>China - Hong Kong SAR Tel: 852-2943-5100</p> <p>China - Nanjing Tel: 86-25-8473-2460</p> <p>China - Qingdao Tel: 86-532-8502-7355</p> <p>China - Shanghai Tel: 86-21-3326-8000</p> <p>China - Shenyang Tel: 86-24-2334-2829</p> <p>China - Shenzhen Tel: 86-755-8864-2200</p> <p>China - Suzhou Tel: 86-186-6233-1526</p> <p>China - Wuhan Tel: 86-27-5980-5300</p> <p>China - Xian Tel: 86-29-8833-7252</p> <p>China - Xiamen Tel: 86-592-2388138</p> <p>China - Zhuhai Tel: 86-756-3210040</p>	<p>India - Bangalore Tel: 91-80-3090-4444</p> <p>India - New Delhi Tel: 91-11-4160-8631</p> <p>India - Pune Tel: 91-20-4121-0141</p> <p>Japan - Osaka Tel: 81-6-6152-7160</p> <p>Japan - Tokyo Tel: 81-3-6880-3770</p> <p>Korea - Daegu Tel: 82-53-744-4301</p> <p>Korea - Seoul Tel: 82-2-554-7200</p> <p>Malaysia - Kuala Lumpur Tel: 60-3-7651-7906</p> <p>Malaysia - Penang Tel: 60-4-227-8870</p> <p>Philippines - Manila Tel: 63-2-634-9065</p> <p>Singapore Tel: 65-6334-8870</p> <p>Taiwan - Hsin Chu Tel: 886-3-577-8366</p> <p>Taiwan - Kaohsiung Tel: 886-7-213-7830</p> <p>Taiwan - Taipei Tel: 886-2-2508-8600</p> <p>Thailand - Bangkok Tel: 66-2-694-1351</p> <p>Vietnam - Ho Chi Minh Tel: 84-28-5448-2100</p>	<p>Austria - Wels Tel: 43-7242-2244-39 Fax: 43-7242-2244-393</p> <p>Denmark - Copenhagen Tel: 45-4485-5910 Fax: 45-4485-2829</p> <p>Finland - Espoo Tel: 358-9-4520-820</p> <p>France - Paris Tel: 33-1-69-53-63-20 Fax: 33-1-69-30-90-79</p> <p>Germany - Garching Tel: 49-8931-9700</p> <p>Germany - Haan Tel: 49-2129-3766400</p> <p>Germany - Heilbronn Tel: 49-7131-72400</p> <p>Germany - Karlsruhe Tel: 49-721-625370</p> <p>Germany - Munich Tel: 49-89-627-144-0 Fax: 49-89-627-144-44</p> <p>Germany - Rosenheim Tel: 49-8031-354-560</p> <p>Israel - Ra'anana Tel: 972-9-744-7705</p> <p>Italy - Milan Tel: 39-0331-742611 Fax: 39-0331-466781</p> <p>Italy - Padova Tel: 39-049-7625286</p> <p>Netherlands - Drunen Tel: 31-416-690399 Fax: 31-416-690340</p> <p>Norway - Trondheim Tel: 47-72884388</p> <p>Poland - Warsaw Tel: 48-22-3325737</p> <p>Romania - Bucharest Tel: 40-21-407-87-50</p> <p>Spain - Madrid Tel: 34-91-708-08-90 Fax: 34-91-708-08-91</p> <p>Sweden - Gothenberg Tel: 46-31-704-60-40</p> <p>Sweden - Stockholm Tel: 46-8-5090-4654</p> <p>UK - Wokingham Tel: 44-118-921-5800 Fax: 44-118-921-5820</p>

Looking for pricing, stock, or lifecycle information?

Click below to explore more details on WIN SOURCE:

- ⊖ [View MTCH1060-I/SS on WIN SOURCE](#)
- ⊖ [Microchip Technology](#) Information

Optimize Your Supply Chain with WIN SOURCE Solutions

- ✓ Global Sourcing Solution
- ✓ Obsolete Management
- ✓ Cost Control Management
- ✓ Shortage Management
- ✓ Alternative Solution
- ✓ Excess Inventory Management