



**THE DATASHEET OF
INA333AIDRGR**



INA333 Micro-Power (50µA), Zero-Drift, Rail-to-Rail Out Instrumentation Amplifier

1 Features

- Low Offset Voltage: 25 µV (Maximum), $G \geq 100$
- Low Drift: 0.1 µV/°C, $G \geq 100$
- Low Noise: 50 nV/√Hz, $G \geq 100$
- High CMRR: 100 dB (Minimum), $G \geq 10$
- Low Input Bias Current: 200 pA (Maximum)
- Supply Range: 1.8 V to 5.5 V
- Input Voltage: (V–) +0.1 V to (V+) –0.1 V
- Output Range: (V–) +0.05 V to (V+) –0.05 V
- Low Quiescent Current: 50 µA
- Operating Temperature: –40°C to +125°C
- RFI Filtered Inputs
- 8-Pin VSSOP and 8-Pin WSON Packages

2 Applications

- Bridge Amplifiers
- ECG Amplifiers
- Pressure Sensors
- Medical Instrumentation
- Portable Instrumentation
- Weigh Scales
- Thermocouple Amplifiers
- RTD Sensor Amplifiers
- Data Acquisition

3 Description

The INA333 device is a low-power, precision instrumentation amplifier offering excellent accuracy. The versatile 3-operational amplifier design, small size, and low power make it ideal for a wide range of portable applications.

A single external resistor sets any gain from 1 to 1000. The INA333 is designed to use an industry-standard gain equation: $G = 1 + (100 \text{ k}\Omega / R_G)$.

The INA333 device provides very low offset voltage (25 µV, $G \geq 100$), excellent offset voltage drift (0.1 µV/°C, $G \geq 100$), and high common-mode rejection (100 dB at $G \geq 10$). It operates with power supplies as low as 1.8 V (± 0.9 V) and quiescent current is only 50 µA, making it ideal for battery-operated systems. Using autocalibration techniques to ensure excellent precision over the extended industrial temperature range, the INA333 device also offers exceptionally low noise density (50 nV/√Hz) that extends down to DC.

The INA333 device is available in both 8-pin VSSOP and WSON surface-mount packages and is specified over the $T_A = -40^\circ\text{C}$ to $+125^\circ\text{C}$ temperature range.

Device Information⁽¹⁾

PART NUMBER	PACKAGE	BODY SIZE (NOM)
INA333	VSSOP (8)	3.00 mm x 3.00 mm
	WSON (8)	3.00 mm x 3.00 mm

(1) For all available packages, see the orderable addendum at the end of the data sheet.

Simplified Schematic

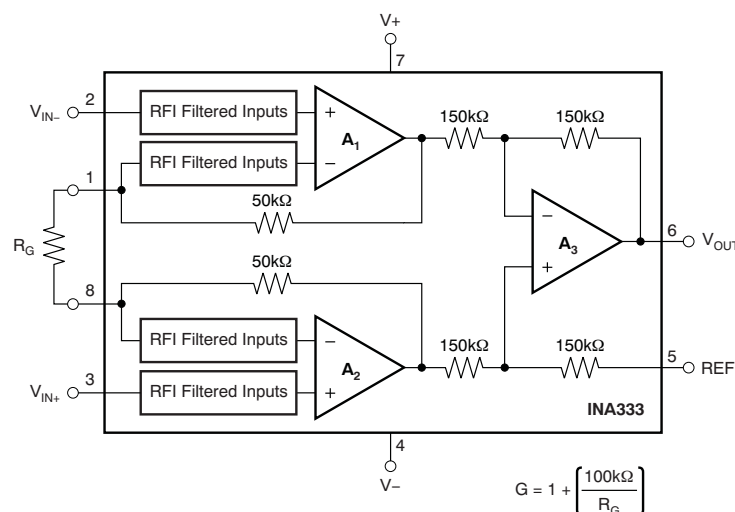

Table of Contents

1 Features 1 2 Applications 1 3 Description 1 4 Revision History 2 5 Pin Configuration and Functions 3 6 Specifications 4 6.1 Absolute Maximum Ratings 4 6.2 ESD Ratings..... 4 6.3 Recommended Operating Conditions 4 6.4 Thermal Information 4 6.5 Electrical Characteristics..... 5 6.6 Typical Characteristics 7 7 Detailed Description 13 7.1 Overview 13 7.2 Functional Block Diagram 13 7.3 Feature Description..... 13	7.4 Device Functional Modes..... 13 8 Application and Implementation 14 8.1 Application Information..... 14 8.2 Typical Application 14 9 Power Supply Recommendations 19 10 Layout 20 10.1 Layout Guidelines 20 10.2 Layout Example 20 11 Device and Documentation Support 21 11.1 Device Support..... 21 11.2 Documentation Support 22 11.3 Trademarks 22 11.4 Electrostatic Discharge Caution..... 22 11.5 Glossary 23 12 Mechanical, Packaging, and Orderable Information 23
--	--

4 Revision History

NOTE: Page numbers for previous revisions may differ from page numbers in the current version.

Changes from Revision B (October 2008) to Revision C

Page

- | | |
|---|-----------------------------|
| <ul style="list-style-type: none"> • Added <i>ESD Ratings</i> table, <i>Feature Description</i> section, <i>Device Functional Modes</i>, <i>Application and Implementation</i> section, <i>Power Supply Recommendations</i> section, <i>Layout</i> section, <i>Device and Documentation Support</i> section, and <i>Mechanical, Packaging, and Orderable Information</i> section | <p style="margin: 0;">1</p> |
|---|-----------------------------|

5 Pin Configuration and Functions

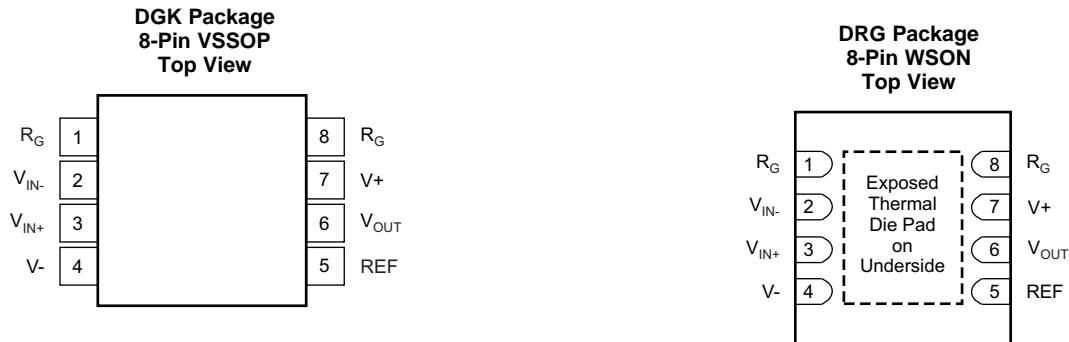

Pin Functions

PIN		I/O	DESCRIPTION
NAME	NO.		
REF	5	I	Reference input. This pin must be driven by low impedance or connected to ground.
RG	1, 8	—	Gain setting pins. For gains greater than 1, place a gain resistor between pins 1 and 8.
V ⁺	7	—	Positive supply
V ⁻	4	—	Negative supply
V _{IN+}	3	I	Positive input
V _{IN-}	2	I	Negative input
V _{OUT}	6	O	Output

6 Specifications

6.1 Absolute Maximum Ratings

over operating free-air temperature range (unless otherwise noted) ⁽¹⁾

	MIN	MAX	UNIT
Supply voltage	7		V
Analog input voltage ⁽²⁾	(V ₋) - 0.3	(V ₊) + 0.3	V
Output short-circuit ⁽³⁾	Continuous		
Operating temperature, T _A	-40	150	°C
Junction temperature, T _J		150	°C
Storage temperature, T _{stg}	-65	150	°C

- (1) Stresses beyond those listed under *Absolute Maximum Ratings* may cause permanent damage to the device. These are stress ratings only, which do not imply functional operation of the device at these or any other conditions beyond those indicated under *Recommended Operating Conditions*. Exposure to absolute-maximum-rated conditions for extended periods may affect device reliability.
- (2) Input pins are diode-clamped to the power-supply rails. Input signals that can swing more than 0.3 V beyond the supply rails should be current limited to 10 mA or less.
- (3) Short-circuit to ground.

6.2 ESD Ratings

		VALUE	UNIT
V _(ESD) Electrostatic discharge	Human-body model (HBM), per ANSI/ESDA/JEDEC JS-001 ⁽¹⁾	±4000	V
	Charged-device model (CDM), per JEDEC specification JESD22-C101 ⁽²⁾	±1000	
	Machine model (MM)	±200	

- (1) JEDEC document JEP155 states that 500-V HBM allows safe manufacturing with a standard ESD control process.
- (2) JEDEC document JEP157 states that 250-V CDM allows safe manufacturing with a standard ESD control process.

6.3 Recommended Operating Conditions

over operating free-air temperature range (unless otherwise noted)

		MIN	MAX	UNIT
V _S	Supply voltage	1.8	5.5	V
	Specified temperature	-40	125	°C

6.4 Thermal Information

THERMAL METRIC ⁽¹⁾		INA333		UNIT
		DGK (VSSOP)	DRG (WSON)	
		8 PINS	8 PINS	
R _{θJA}	Junction-to-ambient thermal resistance	169.5	60	°C/W
R _{θJC(top)}	Junction-to-case (top) thermal resistance	62.7	60	°C/W
R _{θJB}	Junction-to-board thermal resistance	90.3	50	°C/W
ψ _{JT}	Junction-to-top characterization parameter	7.6	—	°C/W
ψ _{JB}	Junction-to-board characterization parameter	88.7	—	°C/W
R _{θJC(bot)}	Junction-to-case (bottom) thermal resistance	—	6	°C/W

- (1) For more information about traditional and new thermal metrics, see the *Semiconductor and IC Package Thermal Metrics* application report, [SPRA953](#).

6.5 Electrical Characteristics

for $V_S = 1.8\text{ V to }5.5\text{ V}$ at $T_A = 25^\circ\text{C}$, $R_L = 10\text{ k}\Omega$, $V_{REF} = V_S / 2$, and $G = 1$ (unless otherwise noted)

PARAMETER		TEST CONDITIONS	MIN	TYP	MAX	UNIT
INPUT⁽¹⁾						
V_{OSI}	Offset voltage, RTI ⁽²⁾			$\pm 10 \pm 25/G$	$\pm 25 \pm 75/G$	μV
	vs temperature	$T_A = -40^\circ\text{C to }+125^\circ\text{C}$			$\pm 0.1 \pm 0.5 / G$	$\mu\text{V}/^\circ\text{C}$
PSR	vs power supply	$1.8\text{ V} \leq V_S \leq 5.5\text{ V}$		$\pm 1 \pm 5/G$	$\pm 5 \pm 15/G$	$\mu\text{V/V}$
	Long-term stability			See ⁽³⁾		
	Turnon time to specified V_{OSI}	$T_A = -40^\circ\text{C to }+125^\circ\text{C}$		See Typical Characteristics		
	Impedance					
Z_{IN}	Differential			100 3		$\text{G}\Omega \parallel \text{pF}$
Z_{IN}	Common-mode			100 3		$\text{G}\Omega \parallel \text{pF}$
V_{CM}	Common-mode voltage range	$V_O = 0\text{ V}$	$(V-) + 0.1$		$(V+) - 0.1$	V
CMR	Common-mode rejection	DC to 60 Hz				
	$G = 1$	$V_{CM} = (V-) + 0.1\text{ V}$ to $(V+) - 0.1\text{ V}$	80	90		dB
	$G = 10$	$V_{CM} = (V-) + 0.1\text{ V}$ to $(V+) - 0.1\text{ V}$	100	110		dB
	$G = 100$	$V_{CM} = (V-) + 0.1\text{ V}$ to $(V+) - 0.1\text{ V}$	100	115		dB
	$G = 1000$	$V_{CM} = (V-) + 0.1\text{ V}$ to $(V+) - 0.1\text{ V}$	100	115		dB
INPUT BIAS CURRENT						
I_B	Input bias current			± 70	± 200	pA
	vs temperature	$T_A = -40^\circ\text{C to }+125^\circ\text{C}$		See Figure 26		$\text{pA}/^\circ\text{C}$
I_{OS}	Input offset current			± 50	± 200	pA
	vs temperature	$T_A = -40^\circ\text{C to }+125^\circ\text{C}$		See Figure 28		$\text{pA}/^\circ\text{C}$
INPUT VOLTAGE NOISE						
e_{NI}	Input voltage noise	$G = 100, R_S = 0\ \Omega, f = 10\text{ Hz}$		50		$\text{nV}/\sqrt{\text{Hz}}$
		$G = 100, R_S = 0\ \Omega, f = 100\text{ Hz}$		50		$\text{nV}/\sqrt{\text{Hz}}$
		$G = 100, R_S = 0\ \Omega, f = 1\text{ kHz}$		50		$\text{nV}/\sqrt{\text{Hz}}$
		$G = 100, R_S = 0\ \Omega, f = 0.1\text{ Hz to }10\text{ Hz}$		1		μV_{PP}
i_N	Input current noise	$f = 10\text{ Hz}$		100		$\text{fA}/\sqrt{\text{Hz}}$
		$f = 0.1\text{ Hz to }10\text{ Hz}$		2		pA_{PP}
GAIN						
G	Gain equation			$1 + (100\text{ k}\Omega/R_G)$		V/V
	Range of gain		1		1000	V/V
Gain error		$V_S = 5.5\text{ V}, (V-) + 100\text{ mV}$ $\leq V_O \leq (V+) - 100\text{ mV}$				
		$G = 1$		$\pm 0.01\%$	$\pm 0.1\%$	
		$G = 10$		$\pm 0.05\%$	$\pm 0.25\%$	
		$G = 100$		$\pm 0.07\%$	$\pm 0.25\%$	
	$G = 1000$		$\pm 0.25\%$	$\pm 0.5\%$		
	Gain vs temperature, $G = 1$	$T_A = -40^\circ\text{C to }+125^\circ\text{C}$		± 1	± 5	$\text{ppm}/^\circ\text{C}$
	Gain vs temperature, $G > 1$ ⁽⁴⁾	$T_A = -40^\circ\text{C to }+125^\circ\text{C}$		± 15	± 50	$\text{ppm}/^\circ\text{C}$
	Gain nonlinearity	$V_S = 5.5\text{ V}, (V-) + 100\text{ mV}$ $\leq V_O \leq (V+) - 100\text{ mV}$				
	Gain nonlinearity, $G = 1$ to 1000	$R_L = 10\text{ k}\Omega$		10		ppm
OUTPUT						
	Output voltage swing from rail	$V_S = 5.5\text{ V}, R_L = 10\text{ k}\Omega$		See Figure 29		50 mV
	Capacitive load drive			500		pF
I_{SC}	Short-circuit current	Continuous to common		-40, +5		mA

(1) Total V_{OS} , referred-to-input = $(V_{OSI}) + (V_{OSO} / G)$

(2) RTI = Referred-to-input

(3) 300-hour life test at 150°C demonstrated randomly distributed variation of approximately $1\ \mu\text{V}$

(4) Does not include effects of external resistor R_G

Electrical Characteristics (continued)

 for $V_S = 1.8\text{ V to }5.5\text{ V}$ at $T_A = 25^\circ\text{C}$, $R_L = 10\text{ k}\Omega$, $V_{REF} = V_S / 2$, and $G = 1$ (unless otherwise noted)

PARAMETER		TEST CONDITIONS	MIN	TYP	MAX	UNIT
FREQUENCY RESPONSE						
Bandwidth, –3dB		$G = 1$		150		kHz
		$G = 10$		35		kHz
		$G = 100$		3.5		kHz
		$G = 1000$		350		Hz
SR	Slew rate	$V_S = 5\text{ V}$, $V_O = 4\text{-V step}$, $G = 1$		0.16		V/ μs
		$V_S = 5\text{ V}$, $V_O = 4\text{-V step}$, $G = 100$		0.05		V/ μs
t_S	Settling time to 0.01%	$V_{STEP} = 4\text{ V}$, $G = 1$		50		μs
		$V_{STEP} = 4\text{ V}$, $G = 100$		400		μs
t_S	Settling time to 0.001%	$V_{STEP} = 4\text{ V}$, $G = 1$		60		μs
		$V_{STEP} = 4\text{ V}$, $G = 100$		500		μs
	Overload recovery	50% overdrive		75		μs
REFERENCE INPUT						
	R_{IN}			300		k Ω
	Voltage range		V–		V+	V
POWER SUPPLY						
Voltage range	Single voltage range		+1.8		+5.5	V
	Dual voltage range		± 0.9		± 2.75	V
I_Q	Quiescent current	$V_{IN} = V_S / 2$		50	75	μA
	vs temperature	$T_A = -40^\circ\text{C to }+125^\circ\text{C}$			80	μA
TEMPERATURE RANGE						
	Specified temperature range		–40		125	$^\circ\text{C}$
	Operating temperature range		–40		150	$^\circ\text{C}$

6.6 Typical Characteristics

at $T_A = 25^\circ\text{C}$, $V_S = 5\text{ V}$, $R_L = 10\text{ k}\Omega$, $V_{REF} = \text{midsupply}$, and $G = 1$ (unless otherwise noted)

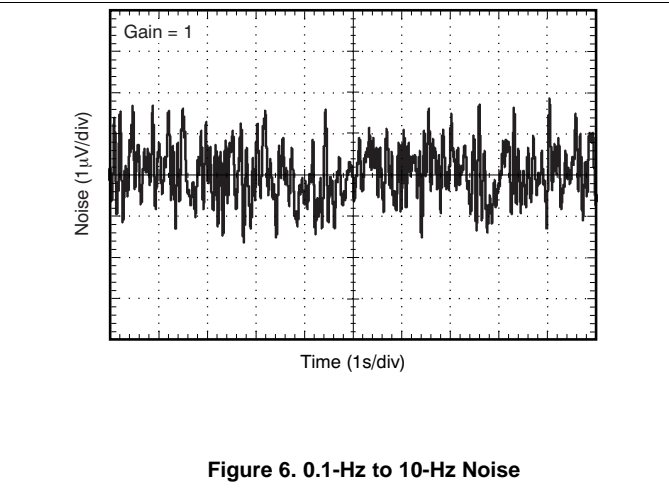
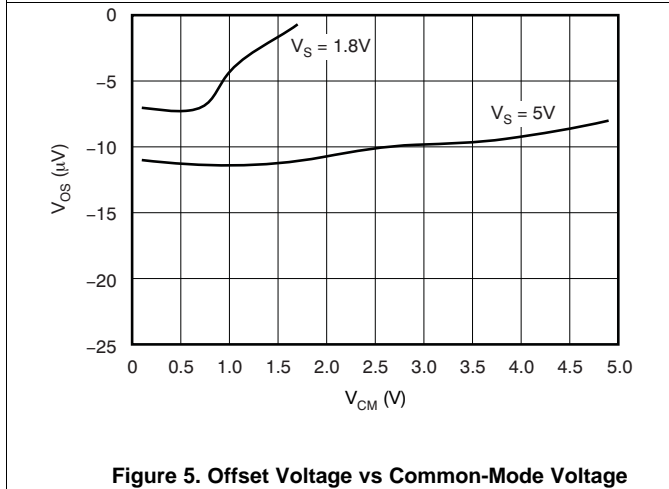
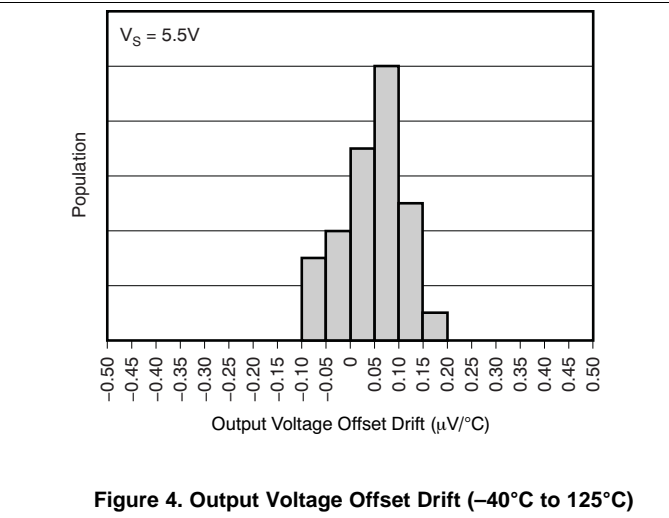
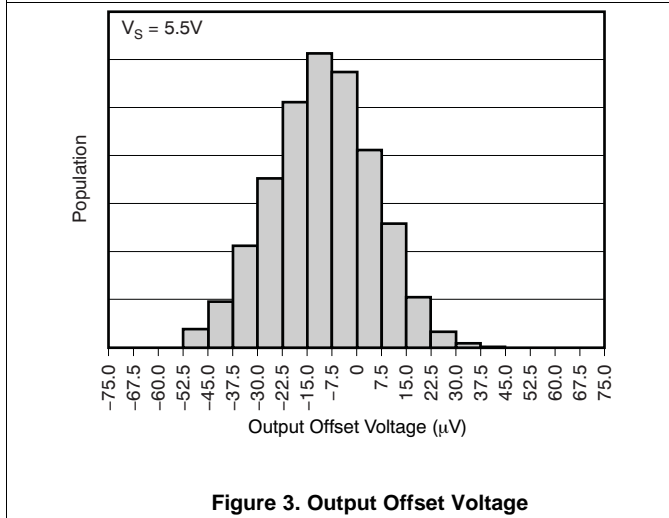
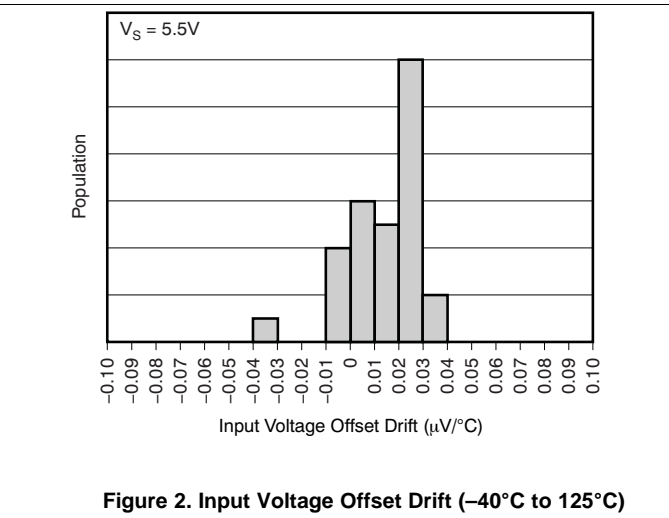
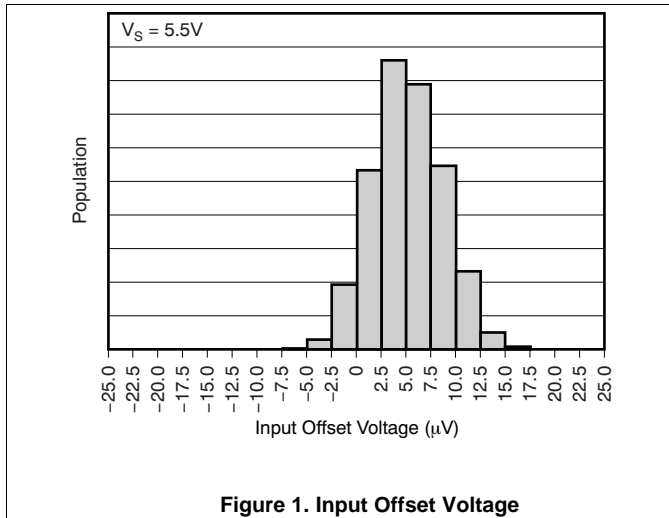

Typical Characteristics (continued)

at $T_A = 25^\circ\text{C}$, $V_S = 5\text{ V}$, $R_L = 10\text{ k}\Omega$, $V_{REF} = \text{midsupply}$, and $G = 1$ (unless otherwise noted)

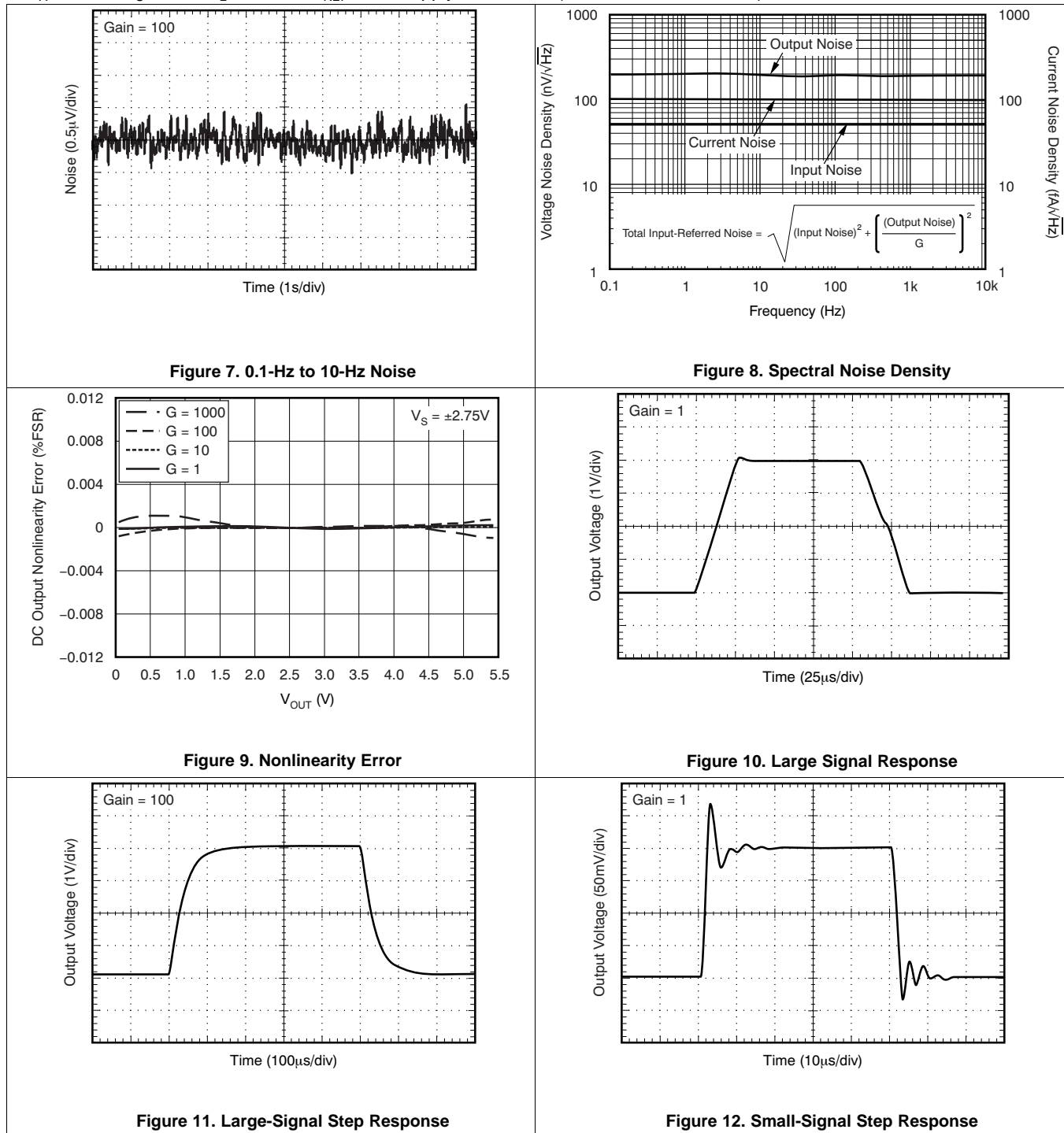

Typical Characteristics (continued)

at $T_A = 25^\circ\text{C}$, $V_S = 5\text{ V}$, $R_L = 10\text{ k}\Omega$, $V_{REF} = \text{mid supply}$, and $G = 1$ (unless otherwise noted)

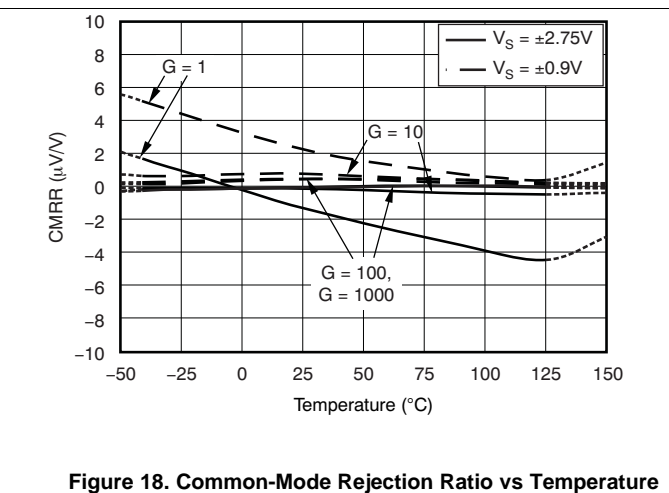
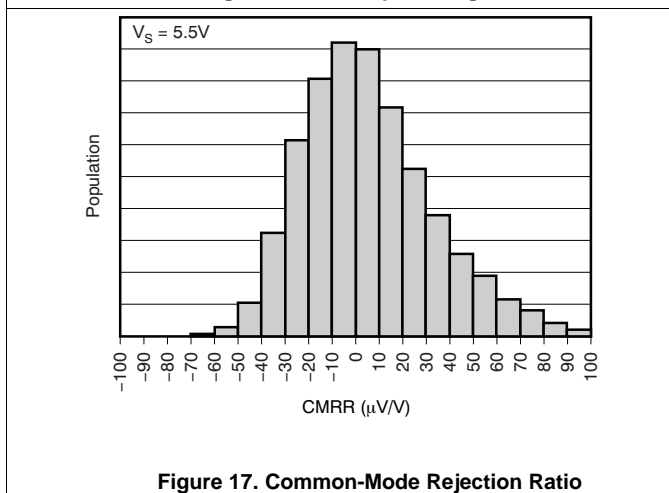
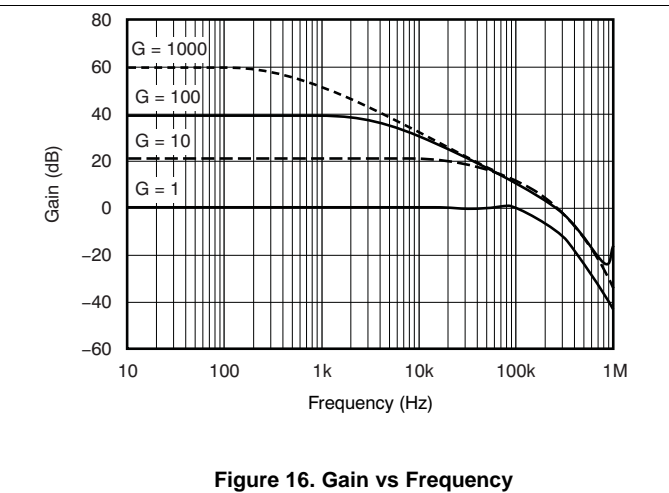
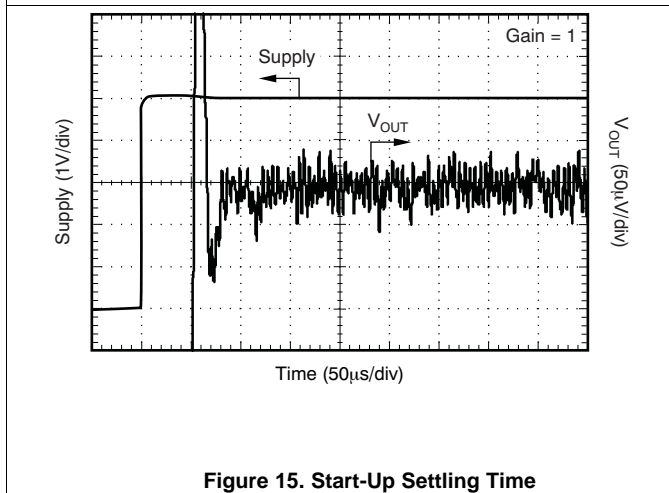
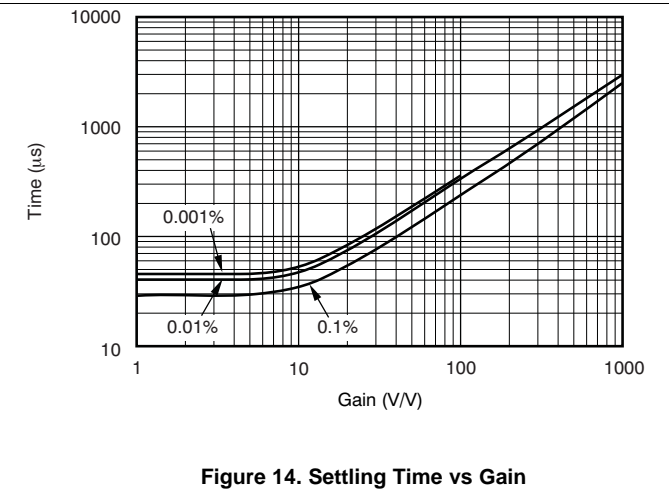
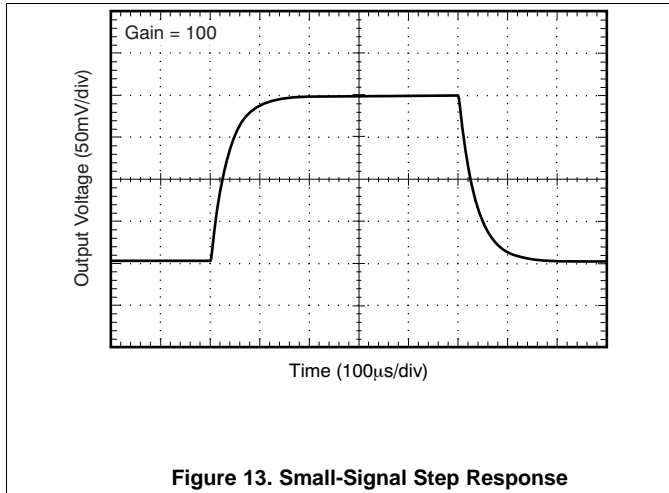

Typical Characteristics (continued)

at $T_A = 25^\circ\text{C}$, $V_S = 5\text{ V}$, $R_L = 10\text{ k}\Omega$, $V_{REF} = \text{mid supply}$, and $G = 1$ (unless otherwise noted)

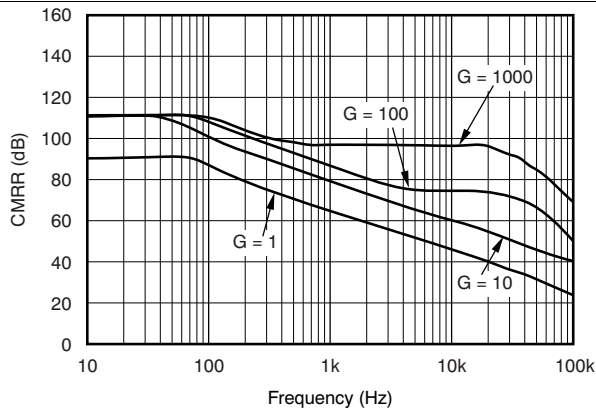

Figure 19. Common-Mode Rejection Ratio vs Frequency

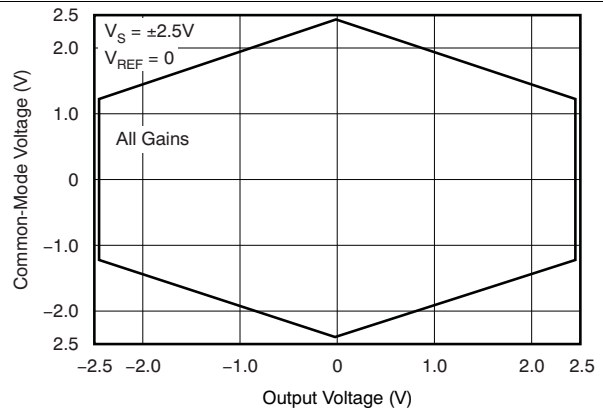

Figure 20. Typical Common-Mode Range vs Output Voltage

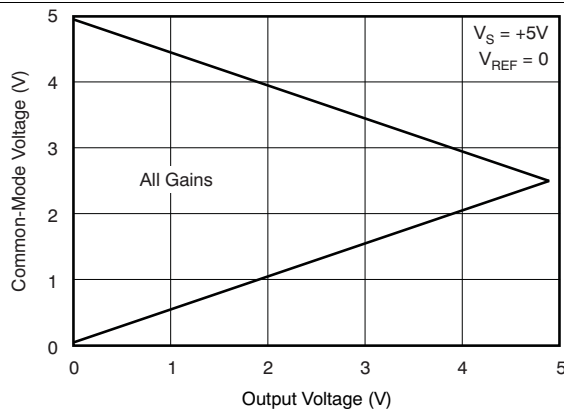

Figure 21. Typical Common-Mode Range vs Output Voltage

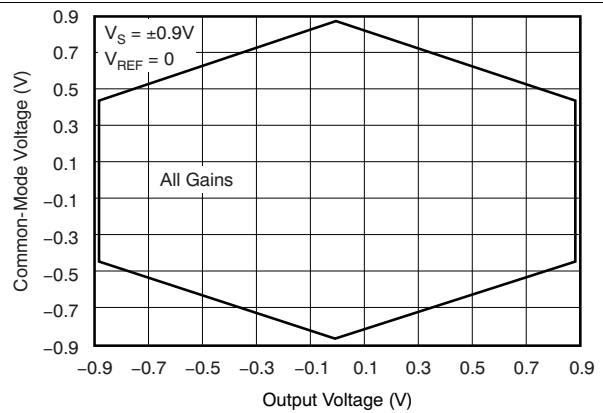

Figure 22. Typical Common-Mode Range vs Output Voltage

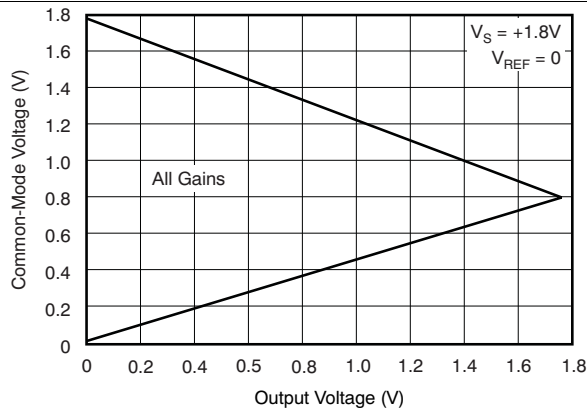

Figure 23. Typical Common-Mode Range vs Output Voltage

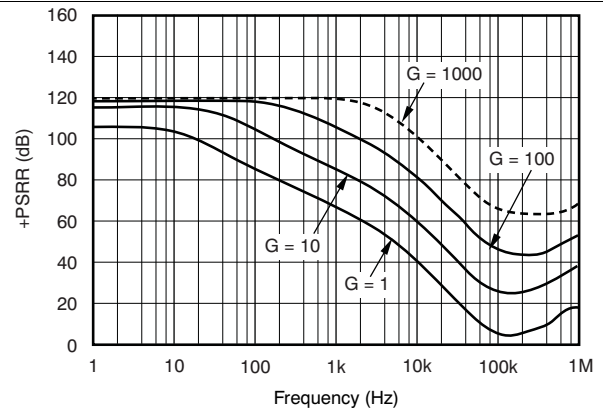

Figure 24. Positive Power-Supply Rejection Ratio

Typical Characteristics (continued)

at $T_A = 25^\circ\text{C}$, $V_S = 5\text{ V}$, $R_L = 10\text{ k}\Omega$, $V_{REF} = \text{mid supply}$, and $G = 1$ (unless otherwise noted)

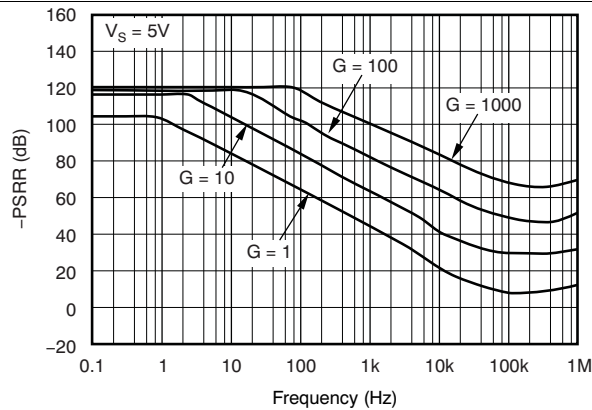

Figure 25. Negative Power-Supply Rejection Ratio

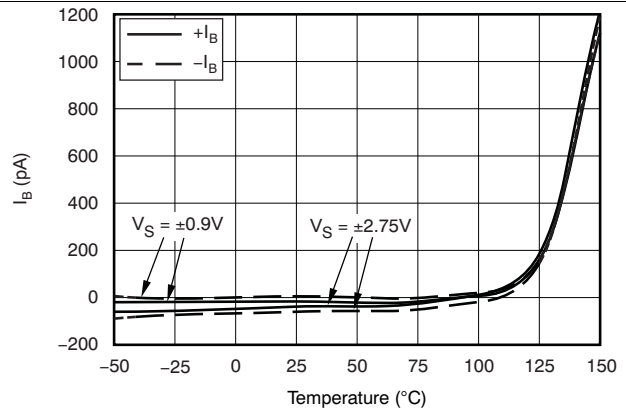

Figure 26. Input Bias Current vs Temperature

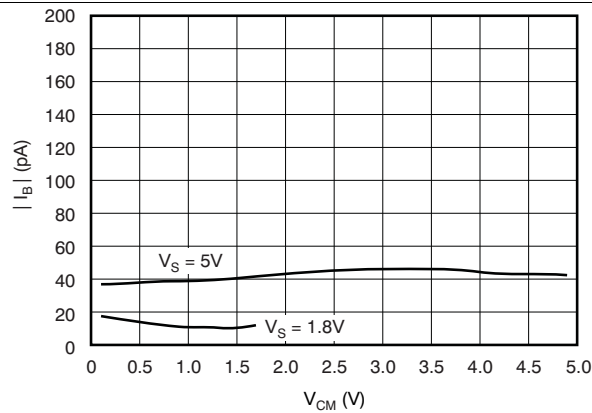

Figure 27. Input Bias Current vs Common-Mode Voltage

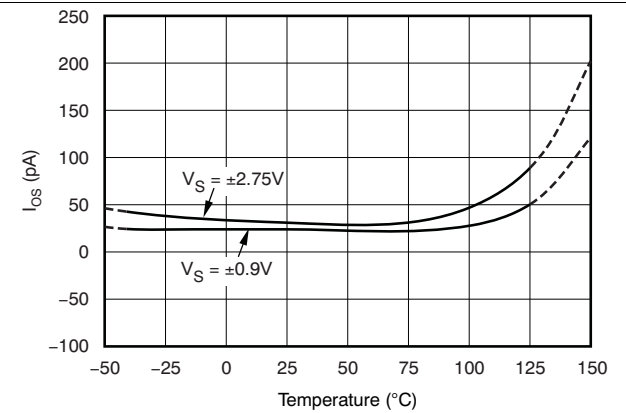

Figure 28. Input Offset Current vs Temperature

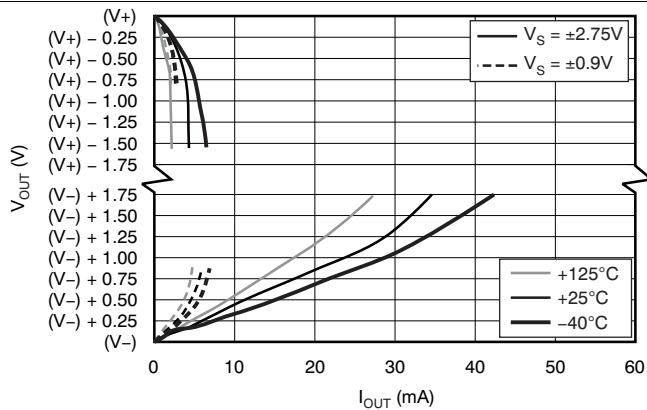

Figure 29. Output Voltage Swing vs Output Current

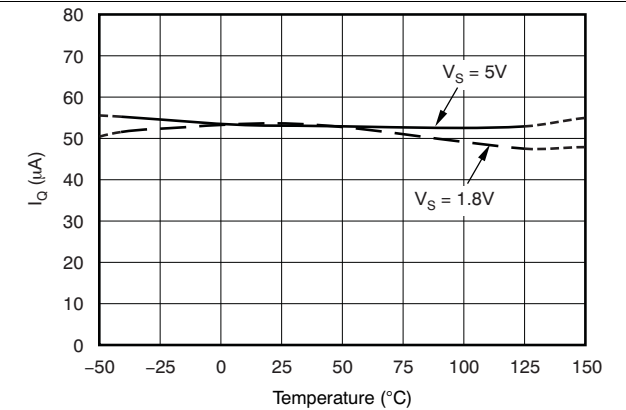

Figure 30. Quiescent Current vs Temperature

Typical Characteristics (continued)

at $T_A = 25^\circ\text{C}$, $V_S = 5\text{ V}$, $R_L = 10\text{ k}\Omega$, $V_{REF} = \text{midsupply}$, and $G = 1$ (unless otherwise noted)

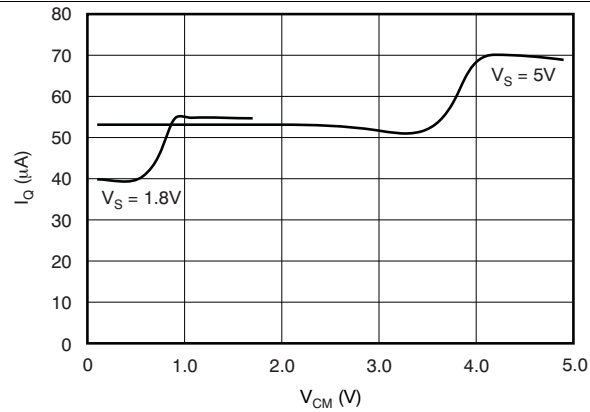

Figure 31. Quiescent Current vs Common-Mode Voltage

7 Detailed Description

7.1 Overview

The INA333 is a monolithic instrumentation amplifier (INA) based on the precision zero-drift OPA333 (operational amplifier) core. The INA333 also integrates laser-trimmed resistors to ensure excellent common-mode rejection and low gain error. The combination of the zero-drift amplifier core and the precision resistors allows this device to achieve outstanding DC precision and makes the INA333 ideal for many 3.3-V and 5-V industrial applications.

7.2 Functional Block Diagram

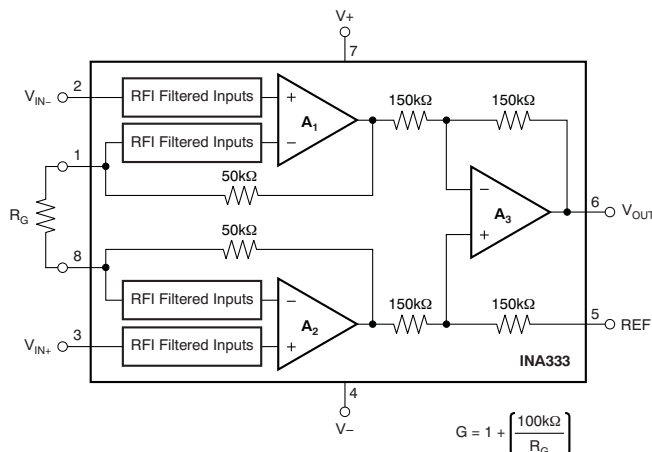

7.3 Feature Description

The INA333 is a low-power, zero-drift instrumentation amplifier offering excellent accuracy. The versatile three-operational-amplifier design and small size make the amplifiers ideal for a wide range of applications. Zero-drift chopper circuitry provides excellent DC specifications. A single external resistor sets any gain from 1 to 10,000. The INA333 is laser trimmed for very high common-mode rejection (100 dB at $G \geq 100$). This devices operate with power supplies as low as 1.8 V, and quiescent current of 50 μA , typically.

7.4 Device Functional Modes

7.4.1 Internal Offset Correction

INA333 internal operational amplifiers use an auto-calibration technique with a time-continuous 350-kHz operational amplifier in the signal path. The amplifier is zero-corrected every 8 μs using a proprietary technique. Upon power up, the amplifier requires approximately 100 μs to achieve specified VOS accuracy. This design has no aliasing or flicker noise.

7.4.2 Input Common-Mode Range

The linear input voltage range of the input circuitry of the INA333 is from approximately 0.1 V below the positive supply voltage to 0.1 V above the negative supply. As a differential input voltage causes the output voltage to increase, however, the linear input range is limited by the output voltage swing of amplifiers A1 and A2. Thus, the linear common-mode input range is related to the output voltage of the complete amplifier. This behavior also depends on supply voltage—see [Figure 20](#).

Input overload conditions can produce an output voltage that appears normal. For example, if an input overload condition drives both input amplifiers to the respective positive output swing limit, the difference voltage measured by the output amplifier is near zero. The output of the INA333 is near 0 V even though both inputs are overloaded.

8 Application and Implementation

NOTE

Information in the following applications sections is not part of the TI component specification, and TI does not warrant its accuracy or completeness. TI's customers are responsible for determining suitability of components for their purposes. Customers should validate and test their design implementation to confirm system functionality.

8.1 Application Information

The INA333 measures small differential voltage with high common-mode voltage developed between the noninverting and inverting input. The high input impedance makes the INA333 suitable for a wide range of applications. The ability to set the reference pin to adjust the functionality of the output signal offers additional flexibility that is practical for multiple configurations.

8.2 Typical Application

Figure 32 shows the basic connections required for operation of the INA333 device. Good layout practice mandates the use of bypass capacitors placed close to the device pins as shown.

The output of the INA333 device is referred to the output reference (REF) pin, which is normally grounded. This connection must be low-impedance to assure good common-mode rejection. Although 15 Ω or less of stray resistance can be tolerated while maintaining specified CMRR, small stray resistances of tens of Ω s in series with the REF pin can cause noticeable degradation in CMRR.

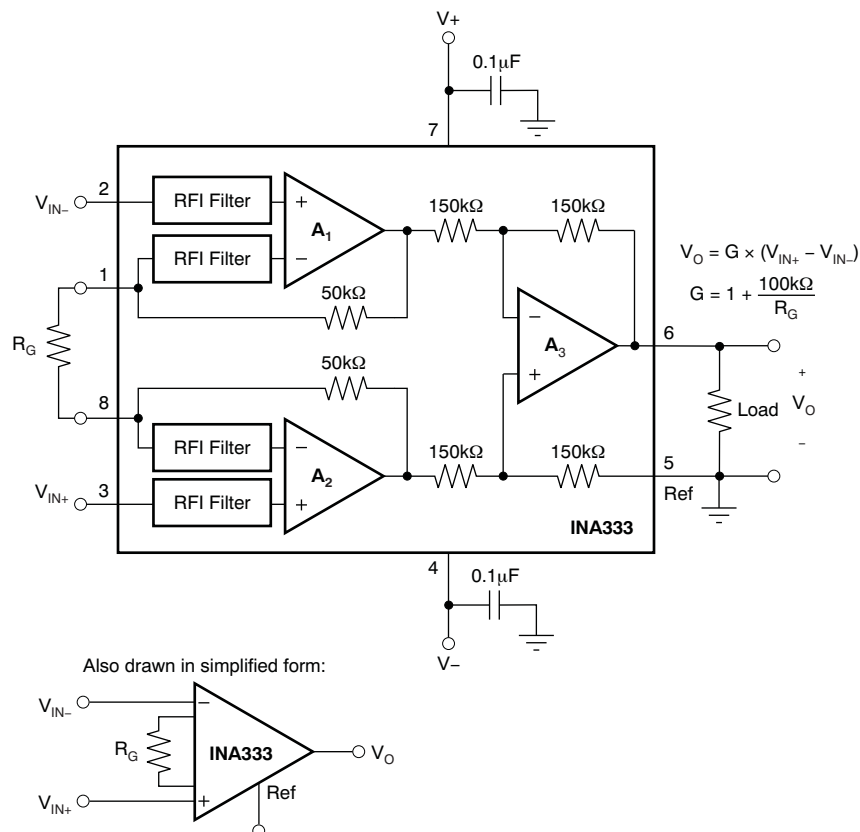

Figure 32. Basic Connections

Typical Application (continued)

8.2.1 Design Requirements

The device can be configured to monitor the input differential voltage when the gain of the input signal is set by the external resistor R_G . The output signal references to the Ref pin. The most common application is where the output is referenced to ground when no input signal is present by connecting the Ref pin to ground. When the input signal increases, the output voltage at the OUT pin increases, too.

8.2.2 Detailed Design Procedure

8.2.2.1 Setting the Gain

Gain of the INA333 device is set by a single external resistor, R_G , connected between pins 1 and 8. The value of R_G is selected according to [Equation 1](#):

$$G = 1 + (100 \text{ k}\Omega / R_G) \quad (1)$$

[Table 1](#) lists several commonly-used gains and resistor values. The 100 k Ω in [Equation 1](#) comes from the sum of the two internal feedback resistors of A_1 and A_2 . These on-chip resistors are laser trimmed to accurate absolute values. The accuracy and temperature coefficient of these resistors are included in the gain accuracy and drift specifications of the INA333 device.

The stability and temperature drift of the external gain setting resistor, R_G , also affects gain. The contribution of R_G to gain accuracy and drift can be directly inferred from the gain [Equation 1](#). Low resistor values required for high gain can make wiring resistance important. Sockets add to the wiring resistance and contribute additional gain error (possibly an unstable gain error) in gains of approximately 100 or greater. To ensure stability, avoid parasitic capacitance of more than a few picofarads at the R_G connections. Careful matching of any parasitics on both R_G pins maintains optimal CMRR over frequency.

Table 1. Commonly-Used Gains and Resistor Values

DESIRED GAIN	R_G (Ω)	NEAREST 1% R_G (Ω)
1	NC ⁽¹⁾	NC
2	100k	100k
5	25k	24.9k
10	11.1k	11k
20	5.26k	5.23k
50	2.04k	2.05
100	1.01k	1k
200	502.5	499
500	200.4	200
1000	100.1	100

(1) NC denotes no connection. When using the SPICE model, the simulation will not converge unless a resistor is connected to the R_G pins; use a very large resistor value.

8.2.2.2 Internal Offset Correction

The INA333 device internal operational amplifiers use an auto-calibration technique with a time-continuous 350-kHz operational amplifier in the signal path. The amplifier is zero-corrected every 8 μ s using a proprietary technique. Upon power-up, the amplifier requires approximately 100 μ s to achieve specified V_{OS} accuracy. This design has no aliasing or flicker noise.

8.2.2.3 Offset Trimming

Most applications require no external offset adjustment; however, if necessary, adjustments can be made by applying a voltage to the REF pin. [Figure 33](#) shows an optional circuit for trimming the output offset voltage. The voltage applied to REF pin is summed at the output. The operational amplifier buffer provides low impedance at the REF pin to preserve good common-mode rejection.

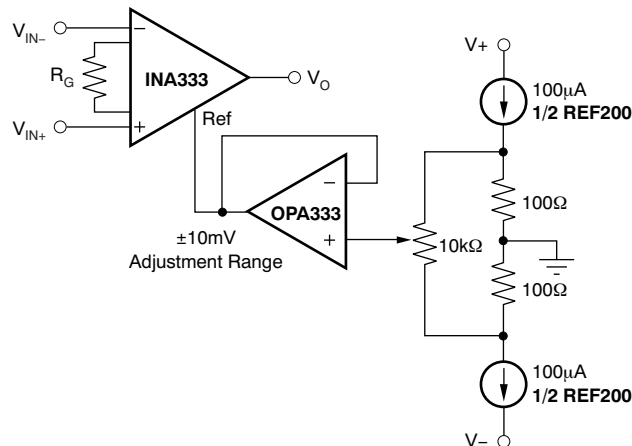

Figure 33. Optional Trimming of Output Offset Voltage

8.2.2.4 Noise Performance

The auto-calibration technique used by the INA333 device results in reduced low frequency noise, typically only $50 \text{ nV}/\sqrt{\text{Hz}}$, ($G = 100$). The spectral noise density can be seen in detail in [Figure 8](#). Low frequency noise of the INA333 device is approximately $1 \text{ } \mu\text{V}_{\text{PP}}$ measured from 0.1 Hz to 10 Hz, ($G = 100$).

8.2.2.5 Input Bias Current Return Path

The input impedance of the INA333 device is extremely high—approximately 100 GΩ. However, a path must be provided for the input bias current of both inputs. This input bias current is typically $\pm 70 \text{ pA}$. High input impedance means that this input bias current changes very little with varying input voltage.

Input circuitry must provide a path for this input bias current for proper operation. [Figure 34](#) shows various provisions for an input bias current path. Without a bias current path, the inputs float to a potential that exceeds the common-mode range of the INA333 device, and the input amplifiers will saturate. If the differential source resistance is low, the bias current return path can be connected to one input (see the thermocouple example in [Figure 34](#)). With higher source impedance, using two equal resistors provides a balanced input with possible advantages of lower input offset voltage as a result of bias current and better high-frequency common-mode rejection.

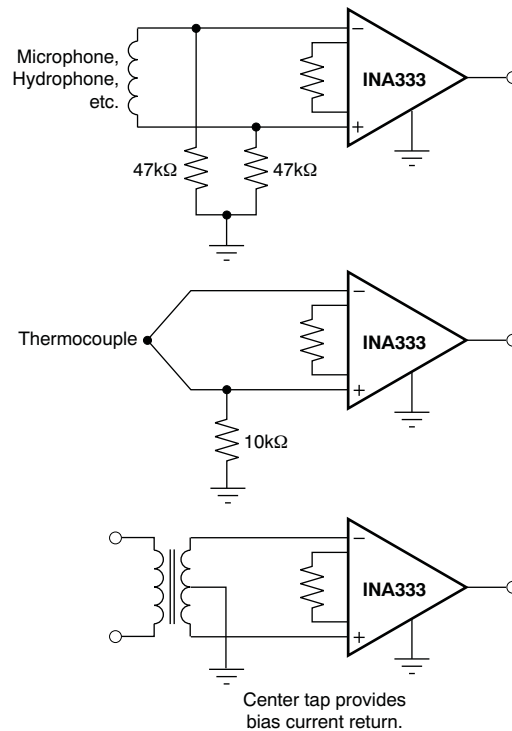

Figure 34. Providing an Input Common-Mode Current Path

8.2.2.6 Input Common-Mode Range

The linear input voltage range of the input circuitry of the INA333 device is from approximately 0.1 V below the positive supply voltage to 0.1 V above the negative supply. As a differential input voltage causes the output voltage to increase, however, the linear input range is limited by the output voltage swing of amplifiers A_1 and A_2 . Thus, the linear common-mode input range is related to the output voltage of the complete amplifier. This behavior also depends on supply voltage—see Figure 20 to Figure 23 in the *Typical Characteristics* section.

Input overload conditions can produce an output voltage that appears normal. For example, if an input overload condition drives both input amplifiers to the respective positive output swing limit, the difference voltage measured by the output amplifier is near zero. The output of the INA333 is near 0 V even though both inputs are overloaded.

8.2.2.7 Operating Voltage

The INA333 operates over a power-supply range of 1.8 V to 5.5 V (± 0.9 V to ± 2.75 V). Supply voltages higher than 7 V (absolute maximum) can permanently damage the device. Parameters that vary over supply voltage or temperature are shown in the *Typical Characteristics* section of this data sheet.

8.2.2.8 Low Voltage Operation

The INA333 device can be operated on power supplies as low as ± 0.9 V. Most parameters vary only slightly throughout this supply voltage range—see the *Typical Characteristics* section. Operation at very low supply voltage requires careful attention to assure that the input voltages remain within the linear range. Voltage swing requirements of internal nodes limit the input common-mode range with low power-supply voltage. Figure 20 to Figure 23 show the range of linear operation for various supply voltages and gains.

8.2.2.9 Single-Supply Operation

The INA333 device can be used on single power supplies of 1.8 V to 5.5 V. Figure 35 shows a basic single-supply circuit. The output REF pin is connected to mid-supply. Zero differential input voltage demands an output voltage of mid-supply. Actual output voltage swing is limited to approximately 50 mV more than ground, when the load is referred to ground as shown. Figure 29 shows how the output voltage swing varies with output current.

With single-supply operation, V_{IN+} and V_{IN-} must both be 0.1 V more than ground for linear operation. For instance, the inverting input cannot be connected to ground to measure a voltage connected to the noninverting input.

To show the issues affecting low voltage operation, consider the circuit in [Figure 35](#). It shows the INA333 device operating from a single 3-V supply. A resistor in series with the low side of the bridge assures that the bridge output voltage is within the common-mode range of the amplifier inputs.

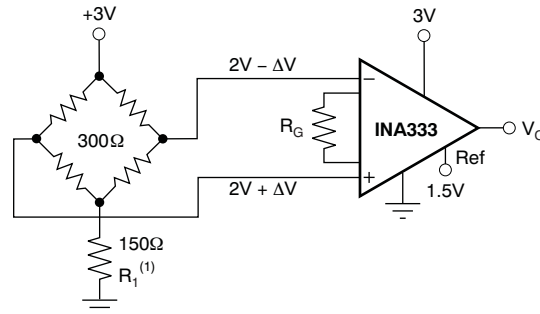

- (1) R_1 creates proper common-mode voltage, only for low-voltage operation—see [Single-Supply Operation](#).

Figure 35. Single-Supply Bridge Amplifier

8.2.2.10 Input Protection

The input pins of the INA333 device are protected with internal diodes connected to the power-supply rails. These diodes clamp the applied signal to prevent it from damaging the input circuitry. If the input signal voltage can exceed the power supplies by more than 0.3 V, the input signal current should be limited to less than 10 mA to protect the internal clamp diodes. This current limiting can generally be done with a series input resistor. Some signal sources are inherently current-limited and do not require limiting resistors.

8.2.3 Application Curves

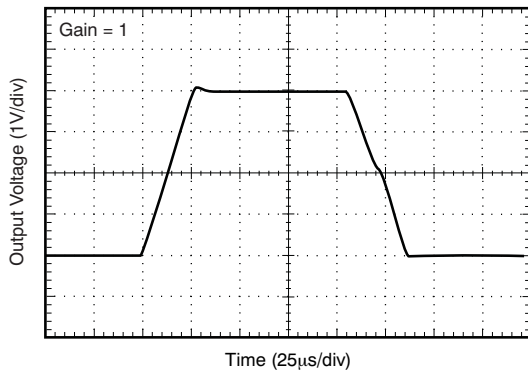

Figure 36. Large Signal Response

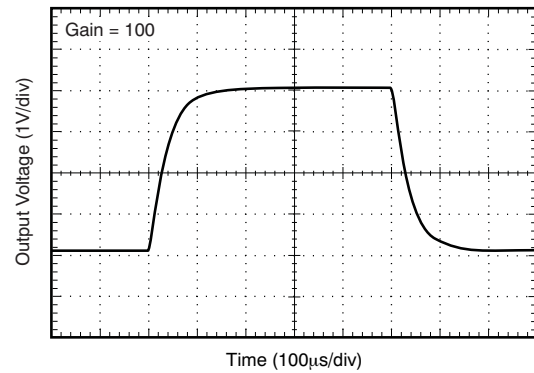

Figure 37. Large-Signal Step Response

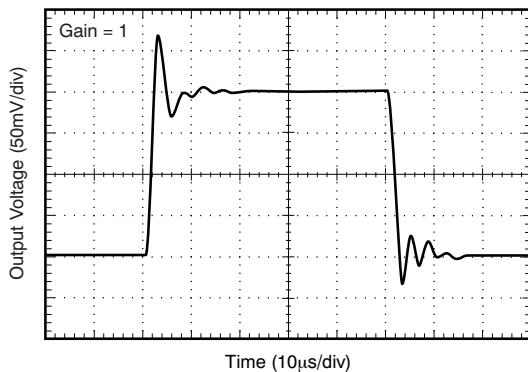

Figure 38. Small-Signal Step Response

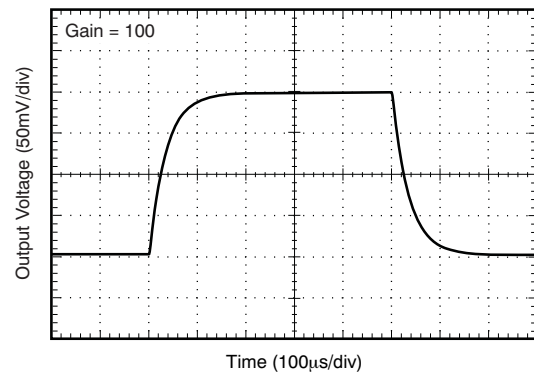

Figure 39. Small-Signal Step Response

9 Power Supply Recommendations

The minimum power supply voltage for INA333 is 1.8 V and the maximum power supply voltage is 5.5 V. For optimum performance, 3.3 V to 5 V is recommended. TI recommends adding a bypass capacitor at the input to compensate for the layout and power supply source impedance.

10 Layout

10.1 Layout Guidelines

Attention to good layout practices is always recommended. Keep traces short and, when possible, use a printed-circuit-board (PCB) ground plane with surface-mount components placed as close to the device pins as possible. Place a 0.1- μF bypass capacitor closely across the supply pins. These guidelines should be applied throughout the analog circuit to improve performance and provide benefits such as reducing the electromagnetic-interference (EMI) susceptibility.

Instrumentation amplifiers vary in the susceptibility to radio-frequency interference (RFI). RFI can generally be identified as a variation in offset voltage or DC signal levels with changes in the interfering RF signal. The INA333 device has been specifically designed to minimize susceptibility to RFI by incorporating passive RC filters with an 8-MHz corner frequency at the $V_{\text{IN}+}$ and $V_{\text{IN}-}$ inputs. As a result, the INA333 device demonstrates remarkably low sensitivity compared to previous generation devices. Strong RF fields may continue to cause varying offset levels, however, and may require additional shielding.

10.2 Layout Example

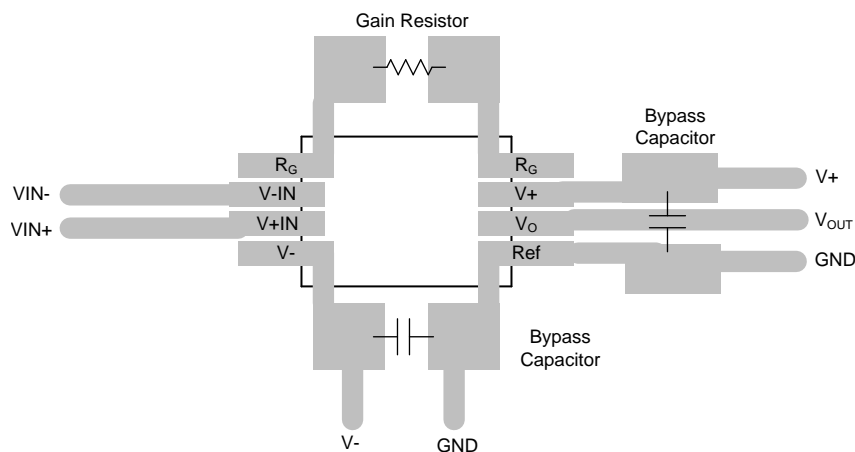

Figure 40. INA333 Layout

11 Device and Documentation Support

11.1 Device Support

11.1.1 Development Support

11.1.1.1 TINA-TI (Free Download Software)

Using TINA-TI SPICE-Based Analog Simulation Program with the INA333

TINA is a simple, powerful, and easy-to-use circuit simulation program based on a SPICE engine. TINA-TI is a free, fully functional version of the TINA software, preloaded with a library of macromodels in addition to a range of both passive and active models. It provides all the conventional DC, transient, and frequency domain analysis of SPICE as well as additional design capabilities.

Available as a free download from the [Analog eLab Design Center](#), TINA-TI offers extensive post-processing capability that allows users to format results in a variety of ways.

Virtual instruments offer users the ability to select input waveforms and probe circuit nodes, voltages, and waveforms, creating a dynamic quick-start tool.

Figure 41 and Figure 42 show example TINA-TI circuits for the INA333 device that can be used to develop, modify, and assess the circuit design for specific applications. Links to download these simulation files are given below.

NOTE

These files require that either the TINA software (from DesignSoft) or TINA-TI software be installed. Download the free TINA-TI software from the TINA-TI folder.

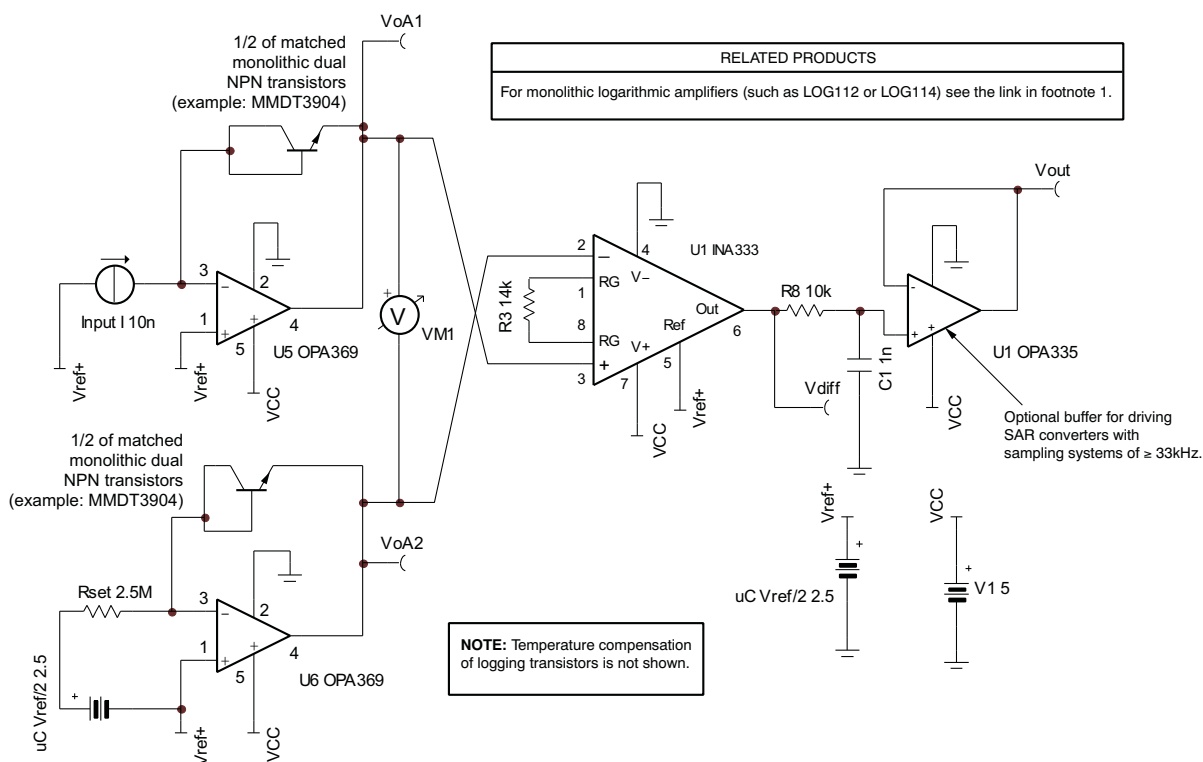

(1) The following link launches the TI logarithmic amplifiers web page: [Logarithmic Amplifier Products Home Page](#)

Figure 41. Low-Power Log Function Circuit for Portable Battery-Powered Systems (Example Glucose Meter)

Device Support (continued)

To download a compressed file that contains the TINA-TI simulation file for this circuit, click the following link: [Log Circuit](#).

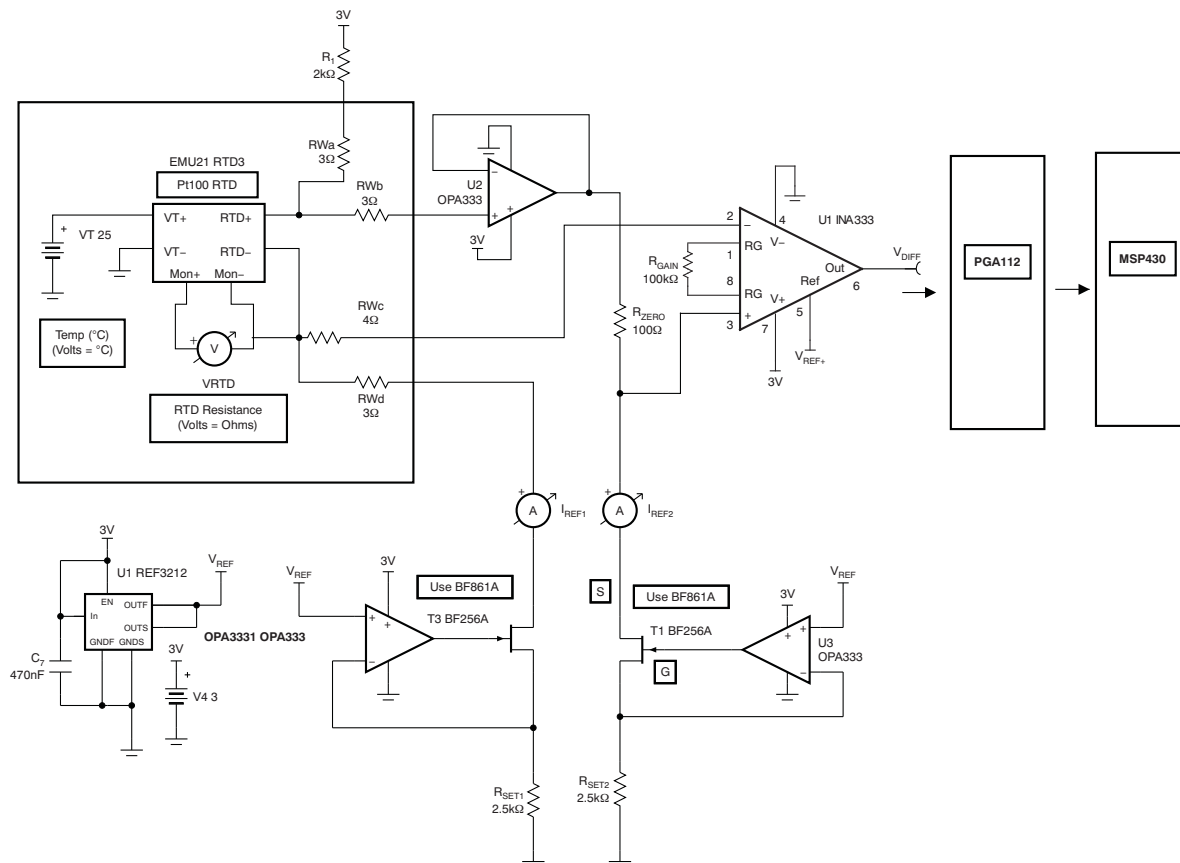

RW_a, RW_b, RW_c, and RW_d simulate wire resistance. These resistors are included to show the four-wire sense technique immunity to line mismatches. This method assumes the use of a four-wire RTD.

Figure 42. Four-Wire, 3-V Conditioner for a PT100 RTD With Programmable Gain Acquisition System

To download a compressed file that contains the TINA-TI simulation file for this circuit, click the following link: [PT100 RTD](#).

11.2 Documentation Support

11.2.1 Related Documentation

For related documentation see the following:

- *Precision, Low-Noise, Rail-to-Rail Output, 36-V, Zero-Drift Operational Amplifiers*, [SBOS642](#)
- *50µV VOS, 0.25µV/°C, 35µA CMOS OPERATIONAL AMPLIFIERS Zero-Drift Series*, [SBOS432](#)
- *4ppm/°C, 100µA, SOT23-6 SERIES VOLTAGE REFERENCE*, [SBVS058](#)
- *Circuit Board Layout Techniques*, [SLOA089](#)

11.3 Trademarks

All trademarks are the property of their respective owners.

11.4 Electrostatic Discharge Caution



These devices have limited built-in ESD protection. The leads should be shorted together or the device placed in conductive foam during storage or handling to prevent electrostatic damage to the MOS gates.

11.5 Glossary

[SLYZ022](#) — *TI Glossary*.

This glossary lists and explains terms, acronyms, and definitions.

12 Mechanical, Packaging, and Orderable Information

The following pages include mechanical, packaging, and orderable information. This information is the most current data available for the designated devices. This data is subject to change without notice and revision of this document. For browser-based versions of this data sheet, refer to the left-hand navigation.

PACKAGING INFORMATION

Orderable Device	Status (1)	Package Type	Package Drawing	Pins	Package Qty	Eco Plan (2)	Lead finish/ Ball material (6)	MSL Peak Temp (3)	Op Temp (°C)	Device Marking (4/5)	Samples
INA333AIDGKR	ACTIVE	VSSOP	DGK	8	2500	RoHS & Green	NIPDAU NIPDAUAG	Level-2-260C-1 YEAR	-40 to 125	I333	Samples
INA333AIDGKRG4	ACTIVE	VSSOP	DGK	8	2500	RoHS & Green	NIPDAU	Level-2-260C-1 YEAR	-40 to 125	I333	Samples
INA333AIDGKT	ACTIVE	VSSOP	DGK	8	250	RoHS & Green	NIPDAU NIPDAUAG	Level-2-260C-1 YEAR	-40 to 125	I333	Samples
INA333AIDGKTG4	ACTIVE	VSSOP	DGK	8	250	RoHS & Green	NIPDAU	Level-2-260C-1 YEAR	-40 to 125	I333	Samples
INA333AIDRGR	ACTIVE	SON	DRG	8	3000	RoHS & Green	NIPDAU	Level-2-260C-1 YEAR	-40 to 125	I333A	Samples
INA333AIDRGT	ACTIVE	SON	DRG	8	250	RoHS & Green	NIPDAU	Level-2-260C-1 YEAR	-40 to 125	I333A	Samples

(1) The marketing status values are defined as follows:

ACTIVE: Product device recommended for new designs.

LIFEBUY: TI has announced that the device will be discontinued, and a lifetime-buy period is in effect.

NRND: Not recommended for new designs. Device is in production to support existing customers, but TI does not recommend using this part in a new design.

PREVIEW: Device has been announced but is not in production. Samples may or may not be available.

OBSOLETE: TI has discontinued the production of the device.

(2) **RoHS:** TI defines "RoHS" to mean semiconductor products that are compliant with the current EU RoHS requirements for all 10 RoHS substances, including the requirement that RoHS substance do not exceed 0.1% by weight in homogeneous materials. Where designed to be soldered at high temperatures, "RoHS" products are suitable for use in specified lead-free processes. TI may reference these types of products as "Pb-Free".

RoHS Exempt: TI defines "RoHS Exempt" to mean products that contain lead but are compliant with EU RoHS pursuant to a specific EU RoHS exemption.

Green: TI defines "Green" to mean the content of Chlorine (Cl) and Bromine (Br) based flame retardants meet JS709B low halogen requirements of <=1000ppm threshold. Antimony trioxide based flame retardants must also meet the <=1000ppm threshold requirement.

(3) MSL, Peak Temp. - The Moisture Sensitivity Level rating according to the JEDEC industry standard classifications, and peak solder temperature.

(4) There may be additional marking, which relates to the logo, the lot trace code information, or the environmental category on the device.

(5) Multiple Device Markings will be inside parentheses. Only one Device Marking contained in parentheses and separated by a "~" will appear on a device. If a line is indented then it is a continuation of the previous line and the two combined represent the entire Device Marking for that device.

(6) Lead finish/Ball material - Orderable Devices may have multiple material finish options. Finish options are separated by a vertical ruled line. Lead finish/Ball material values may wrap to two lines if the finish value exceeds the maximum column width.

Important Information and Disclaimer: The information provided on this page represents TI's knowledge and belief as of the date that it is provided. TI bases its knowledge and belief on information provided by third parties, and makes no representation or warranty as to the accuracy of such information. Efforts are underway to better integrate information from third parties. TI has taken and continues to take reasonable steps to provide representative and accurate information but may not have conducted destructive testing or chemical analysis on incoming materials and chemicals. TI and TI suppliers consider certain information to be proprietary, and thus CAS numbers and other limited information may not be available for release.

In no event shall TI's liability arising out of such information exceed the total purchase price of the TI part(s) at issue in this document sold by TI to Customer on an annual basis.

OTHER QUALIFIED VERSIONS OF INA333 :

- Automotive : [INA333-Q1](#)

NOTE: Qualified Version Definitions:

- Automotive - Q100 devices qualified for high-reliability automotive applications targeting zero defects

TAPE AND REEL INFORMATION

QUADRANT ASSIGNMENTS FOR PIN 1 ORIENTATION IN TAPE

*All dimensions are nominal

Device	Package Type	Package Drawing	Pins	SPQ	Reel Diameter (mm)	Reel Width W1 (mm)	A0 (mm)	B0 (mm)	K0 (mm)	P1 (mm)	W (mm)	Pin1 Quadrant
INA333AIDGKR	VSSOP	DGK	8	2500	330.0	12.4	5.3	3.4	1.4	8.0	12.0	Q1
INA333AIDGKT	VSSOP	DGK	8	250	330.0	12.4	5.3	3.4	1.4	8.0	12.0	Q1
INA333AIDRGR	SON	DRG	8	3000	330.0	12.4	3.3	3.3	1.1	8.0	12.0	Q2
INA333AIDRGT	SON	DRG	8	250	180.0	12.4	3.3	3.3	1.1	8.0	12.0	Q2

TAPE AND REEL BOX DIMENSIONS



*All dimensions are nominal

Device	Package Type	Package Drawing	Pins	SPQ	Length (mm)	Width (mm)	Height (mm)
INA333AIDGKR	VSSOP	DGK	8	2500	366.0	364.0	50.0
INA333AIDGKT	VSSOP	DGK	8	250	366.0	364.0	50.0
INA333AIDRGR	SON	DRG	8	3000	356.0	356.0	35.0
INA333AIDRGT	SON	DRG	8	250	210.0	185.0	35.0

DRG (S-PWSON-N8)

PLASTIC SMALL OUTLINE NO-LEAD

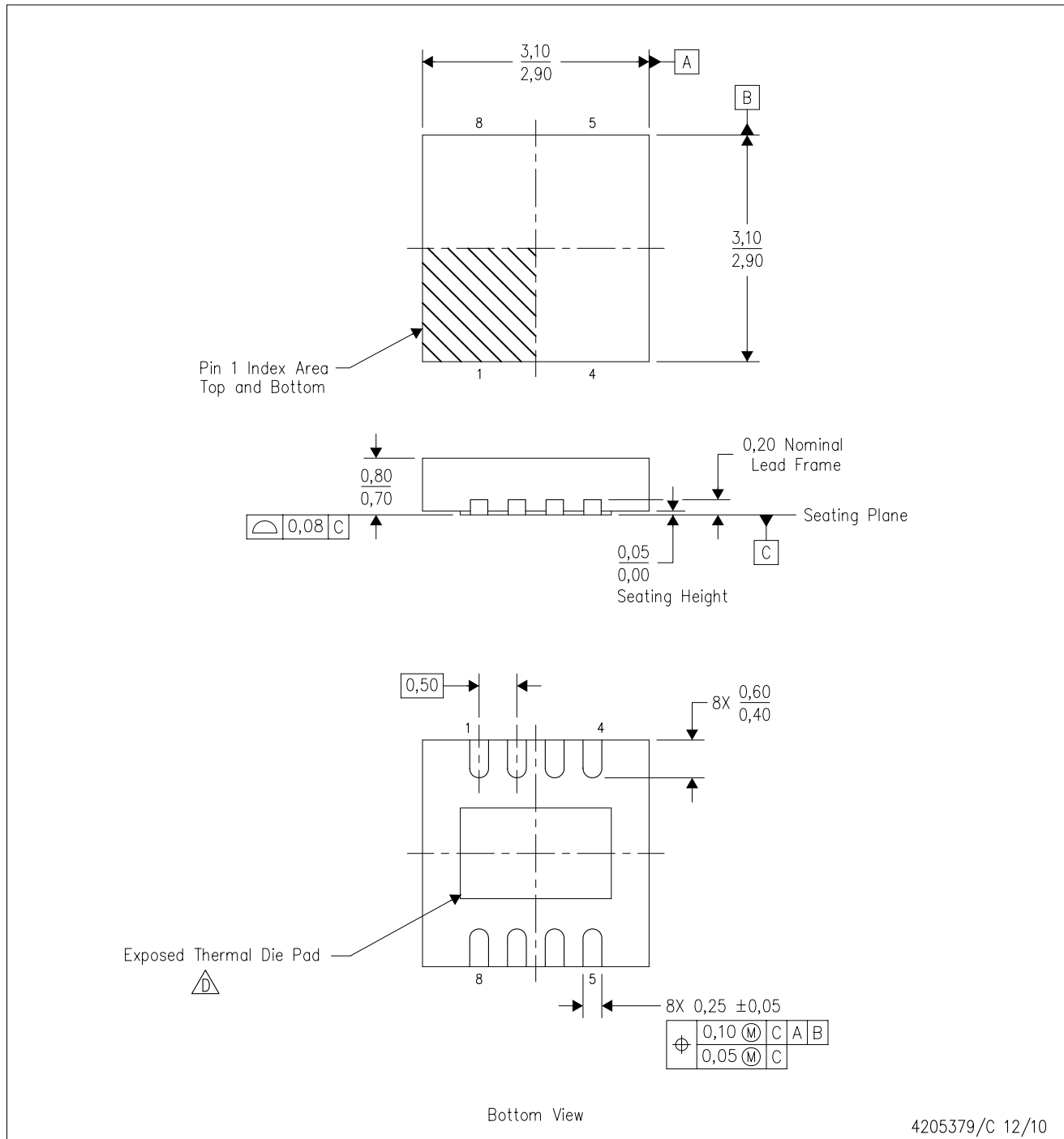

- NOTES:
- A. All linear dimensions are in millimeters. Dimensioning and tolerancing per ASME Y14.5M-1994.
 - B. This drawing is subject to change without notice.
 - C. SON (Small Outline No-Lead) package configuration.
 - D. The package thermal pad must be soldered to the board for thermal and mechanical performance. See the Product Data Sheet for details regarding the exposed thermal pad dimensions.
 - E. JEDEC MO-229 package registration pending.

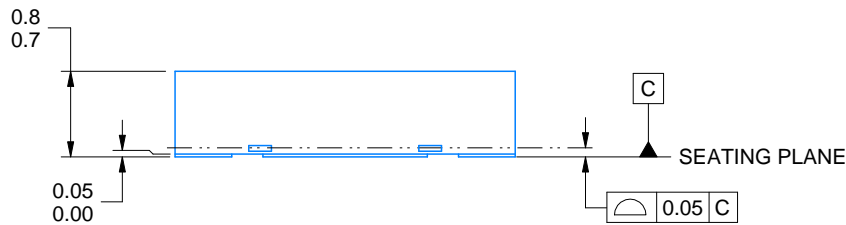
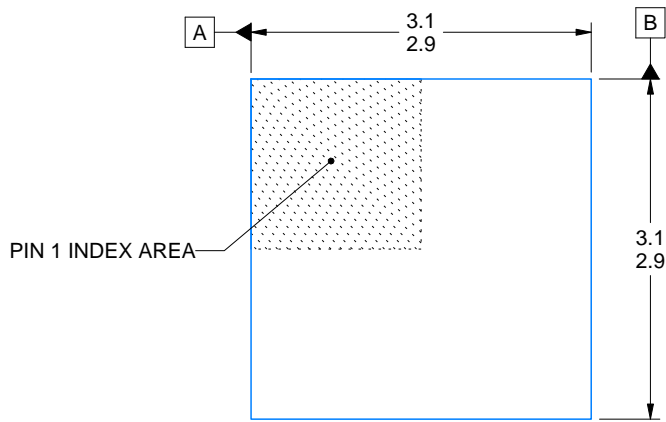
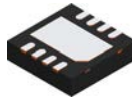

DIMENSION A	
OPTION 01	(0.1)
OPTION 02	(0.2)

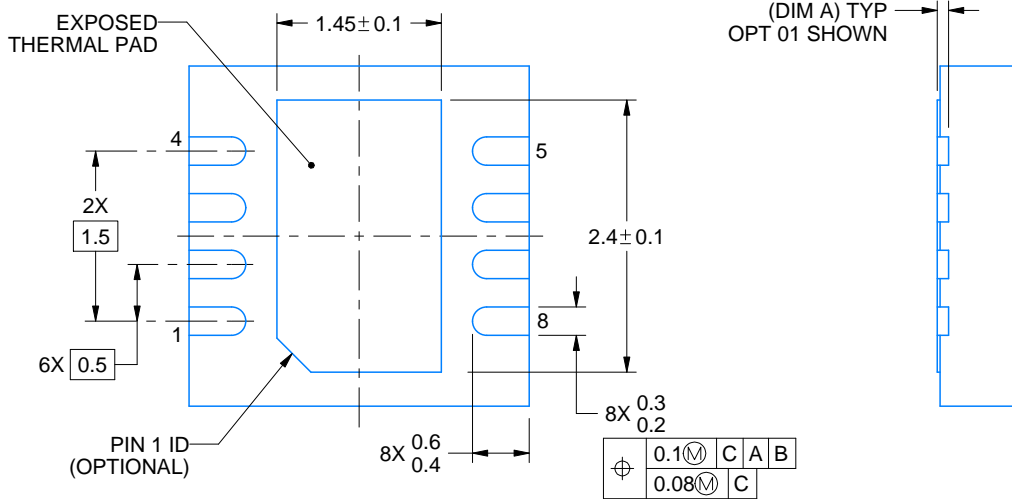

4218886/A 01/2020

NOTES:

1. All linear dimensions are in millimeters. Any dimensions in parenthesis are for reference only. Dimensioning and tolerancing per ASME Y14.5M.
2. This drawing is subject to change without notice.
3. The package thermal pad must be soldered to the printed circuit board for thermal and mechanical performance.

EXAMPLE STENCIL DESIGN

DRG0008B

WSO - 0.8 mm max height

PLASTIC SMALL OUTLINE - NO LEAD

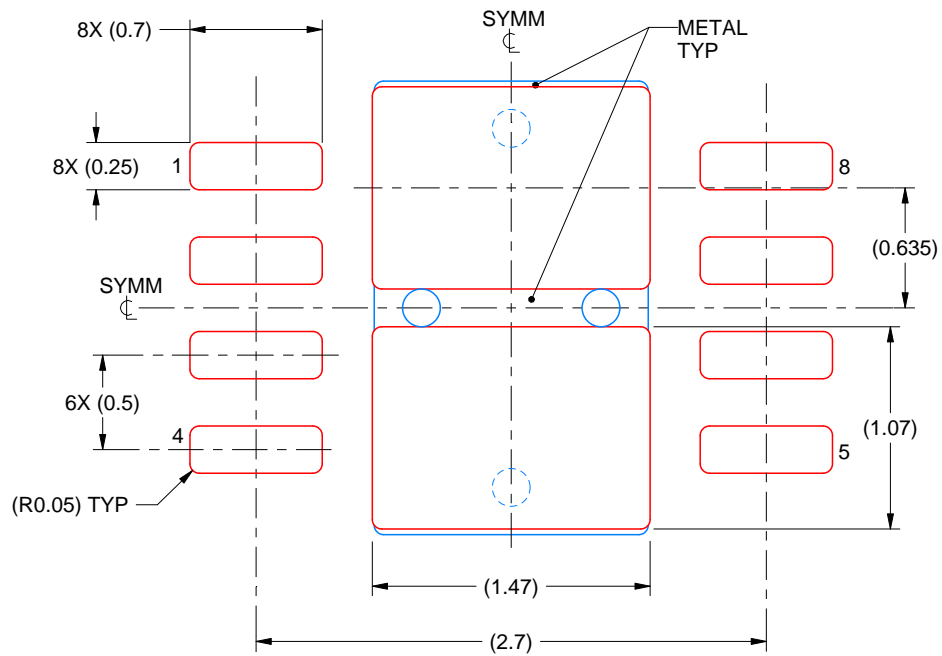

SOLDER PASTE EXAMPLE
BASED ON 0.125 mm THICK STENCIL

EXPOSED PAD
82% PRINTED SOLDER COVERAGE BY AREA
SCALE:25X

4218886/A 01/2020

NOTES: (continued)

6. Laser cutting apertures with trapezoidal walls and rounded corners may offer better paste release. IPC-7525 may have alternate design recommendations.

DGK0008A



PACKAGE OUTLINE

VSSOP - 1.1 mm max height

SMALL OUTLINE PACKAGE



NOTES:

PowerPAD is a trademark of Texas Instruments.

1. All linear dimensions are in millimeters. Any dimensions in parenthesis are for reference only. Dimensioning and tolerancing per ASME Y14.5M.
2. This drawing is subject to change without notice.
3. This dimension does not include mold flash, protrusions, or gate burrs. Mold flash, protrusions, or gate burrs shall not exceed 0.15 mm per side.
4. This dimension does not include interlead flash. Interlead flash shall not exceed 0.25 mm per side.
5. Reference JEDEC registration MO-187.

EXAMPLE BOARD LAYOUT

DGK0008A

™ VSSOP - 1.1 mm max height

SMALL OUTLINE PACKAGE



LAND PATTERN EXAMPLE
EXPOSED METAL SHOWN
SCALE: 15X



SOLDER MASK DETAILS

4214862/A 04/2023

NOTES: (continued)

6. Publication IPC-7351 may have alternate designs.
7. Solder mask tolerances between and around signal pads can vary based on board fabrication site.
8. Vias are optional depending on application, refer to device data sheet. If any vias are implemented, refer to their locations shown on this view. It is recommended that vias under paste be filled, plugged or tented.
9. Size of metal pad may vary due to creepage requirement.

EXAMPLE STENCIL DESIGN

DGK0008A

TM VSSOP - 1.1 mm max height

SMALL OUTLINE PACKAGE



SOLDER PASTE EXAMPLE
SCALE: 15X

4214862/A 04/2023

NOTES: (continued)

11. Laser cutting apertures with trapezoidal walls and rounded corners may offer better paste release. IPC-7525 may have alternate design recommendations.
12. Board assembly site may have different recommendations for stencil design.

IMPORTANT NOTICE AND DISCLAIMER

TI PROVIDES TECHNICAL AND RELIABILITY DATA (INCLUDING DATA SHEETS), DESIGN RESOURCES (INCLUDING REFERENCE DESIGNS), APPLICATION OR OTHER DESIGN ADVICE, WEB TOOLS, SAFETY INFORMATION, AND OTHER RESOURCES "AS IS" AND WITH ALL FAULTS, AND DISCLAIMS ALL WARRANTIES, EXPRESS AND IMPLIED, INCLUDING WITHOUT LIMITATION ANY IMPLIED WARRANTIES OF MERCHANTABILITY, FITNESS FOR A PARTICULAR PURPOSE OR NON-INFRINGEMENT OF THIRD PARTY INTELLECTUAL PROPERTY RIGHTS.

These resources are intended for skilled developers designing with TI products. You are solely responsible for (1) selecting the appropriate TI products for your application, (2) designing, validating and testing your application, and (3) ensuring your application meets applicable standards, and any other safety, security, regulatory or other requirements.

These resources are subject to change without notice. TI grants you permission to use these resources only for development of an application that uses the TI products described in the resource. Other reproduction and display of these resources is prohibited. No license is granted to any other TI intellectual property right or to any third party intellectual property right. TI disclaims responsibility for, and you will fully indemnify TI and its representatives against, any claims, damages, costs, losses, and liabilities arising out of your use of these resources.

TI's products are provided subject to [TI's Terms of Sale](#) or other applicable terms available either on [ti.com](https://www.ti.com) or provided in conjunction with such TI products. TI's provision of these resources does not expand or otherwise alter TI's applicable warranties or warranty disclaimers for TI products.

TI objects to and rejects any additional or different terms you may have proposed.

Mailing Address: Texas Instruments, Post Office Box 655303, Dallas, Texas 75265
Copyright © 2024, Texas Instruments Incorporated

Looking for pricing, stock, or lifecycle information?

Click below to explore more details on WIN SOURCE:

 [View INA333AIDRGR on WIN SOURCE](#)

 [Texas Instruments](#) Information

Optimize Your Supply Chain with WIN SOURCE Solutions

-  Global Sourcing Solution
-  Obsolete Management
-  Cost Control Management
-  Shortage Management
-  Alternative Solution
-  Excess Inventory Management