

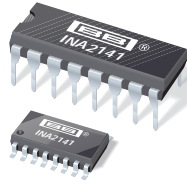

THE DATASHEET OF INA2141UA





INA2141

Dual, Low Power, $G = 10, 100$ INSTRUMENTATION AMPLIFIER

FEATURES

- **LOW OFFSET VOLTAGE:** $50\mu\text{V}$ max
- **LOW DRIFT:** $0.5\mu\text{V}/^\circ\text{C}$ max
- **EXCELLENT GAIN ACCURACY:**
 $\pm 0.05\%$ max at $G = 10$
- **LOW INPUT BIAS CURRENT:** 5nA max
- **HIGH CMR:** 117dB min ($G = 100$)
- **INPUTS PROTECTED TO $\pm 40\text{V}$**
- **WIDE SUPPLY RANGE:** $\pm 2.25\text{V}$ to $\pm 18\text{V}$
- **LOW QUIESCENT CURRENT:** $750\mu\text{A}/\text{A}$
- **16-PIN PLASTIC DIP, SOL-16**

APPLICATIONS

- **SENSOR AMPLIFIER**
THERMOCOUPLE, RTD, BRIDGE
- **MEDICAL INSTRUMENTATION**
- **MULTIPLE CHANNEL SYSTEMS**

DESCRIPTION

The INA2141 is a low power, dual instrumentation amplifier offering excellent accuracy. Its versatile 3-op amp design and small size make it ideal for a wide range of applications. Current-feedback input circuitry provides wide bandwidth even at high gain (200kHz at $G = 100$).

Simple pin connections set an accurate gain of 10 or $100\text{V}/\text{V}$ without external resistors. Internal input protection can withstand up to $\pm 40\text{V}$ without damage.

The INA2141 is laser trimmed for very low offset voltage ($50\mu\text{V}$), drift ($0.5\mu\text{V}/^\circ\text{C}$) and high common-mode rejection (117dB at $G = 100$). It operates with power supplies as low as $\pm 2.25\text{V}$, and quiescent current is only $750\mu\text{A}$ per amplifier—ideal for battery operated systems.

Packages are 16-pin plastic DIP, and SOL-16 surface-mount, specified for the -40°C to $+85^\circ\text{C}$ temperature range.

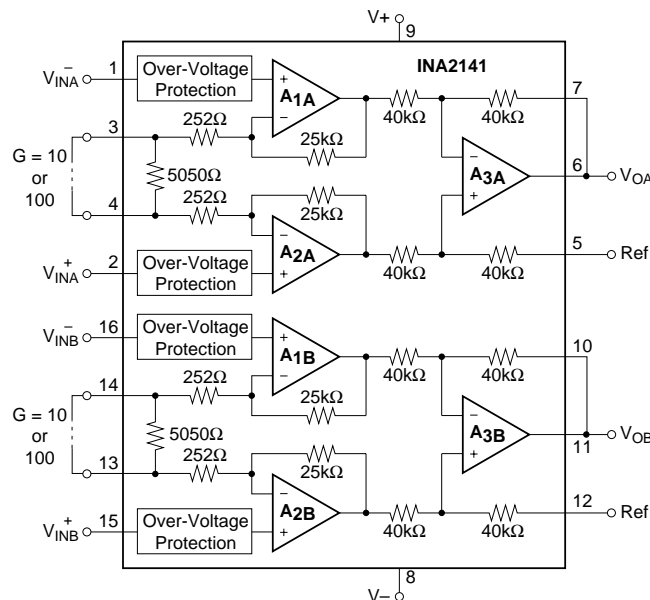

International Airport Industrial Park • Mailing Address: PO Box 11400, Tucson, AZ 85734 • Street Address: 6730 S. Tucson Blvd., Tucson, AZ 85706 • Tel: (520) 746-1111 • Twx: 910-952-1111
Internet: <http://www.burr-brown.com/> • FAXLine: (800) 548-6133 (US/Canada Only) • Cable: BBRCORP • Telex: 066-6491 • FAX: (520) 889-1510 • Immediate Product Info: (800) 548-6132

SPECIFICATIONS

At $T_A = +25^\circ\text{C}$, $V_S = \pm 15\text{V}$, and $R_L = 10\text{k}\Omega$, unless otherwise noted.

PARAMETER	CONDITIONS	INA2141P, U			INA2141PA, UA			UNITS
		MIN	TYP	MAX	MIN	TYP	MAX	
INPUT								
Offset Voltage, RTI	$G = 100$		± 20	± 50		*	± 125	μV
	$G = 10$		± 50	± 100		*	± 250	μV
vs Temperature	$G = 100$		± 0.2	± 0.5		*	± 1.5	$\mu\text{V}/^\circ\text{C}$
	$G = 10^{(2)}$		± 0.5	± 2		*	± 5	$\mu\text{V}/^\circ\text{C}$
vs Power Supply	$V_S = \pm 2.25$ to $\pm 18\text{V}$, $G = 100$		± 1	± 2		*	± 5	$\mu\text{V}/\text{V}$
	$G = 10$		± 2	± 10		*	± 20	$\mu\text{V}/\text{V}$
Long-Term Stability	$G = 100$		0.2			*		$\mu\text{V}/\text{mo}$
	$G = 10$		0.5			*		$\mu\text{V}/\text{mo}$
Impedance, Differential			$10^{10} \parallel 2$			*		$\Omega \parallel \text{pF}$
Common-Mode			$10^{10} \parallel 9$			*		$\Omega \parallel \text{pF}$
Common-Mode Voltage Range ⁽¹⁾	$V_O = 0\text{V}$	$(V+) - 2$ $(V-) + 2$	$(V+) - 1.4$ $(V-) + 1.7$		*	*		V
Safe Input Voltage				± 40			*	V
Common-Mode Rejection	$V_{CM} = \pm 13\text{V}$, $\Delta R_S = 1\text{k}\Omega$							
	$G = 100$	117	125		110	120		dB
	$G = 10$	97	106		93	100		dB
BIAS CURRENT								
vs Temperature			± 2	± 5		*	± 10	nA
Offset Current			± 30			*		$\text{pA}/^\circ\text{C}$
vs Temperature			± 1	± 5		*	± 10	nA
			± 30			*		$\text{pA}/^\circ\text{C}$
NOISE VOLTAGE, RTI								
$f = 10\text{Hz}$	$G = 100$, $R_S = 0\Omega$		10			*		$\text{nV}/\sqrt{\text{Hz}}$
$f = 100\text{Hz}$			8			*		$\text{nV}/\sqrt{\text{Hz}}$
$f = 1\text{kHz}$			8			*		$\text{nV}/\sqrt{\text{Hz}}$
$f_B = 0.1\text{Hz}$ to 10Hz			0.2			*		$\mu\text{Vp-p}$
$f = 10\text{Hz}$	$G = 10$, $R_S = 0\Omega$		22			*		$\text{nV}/\sqrt{\text{Hz}}$
$f = 100\text{Hz}$			13			*		$\text{nV}/\sqrt{\text{Hz}}$
$f = 1\text{kHz}$			12			*		$\text{nV}/\sqrt{\text{Hz}}$
$f_B = 0.1\text{Hz}$ to 10Hz			0.6			*		$\mu\text{Vp-p}$
Noise Current								
$f = 10\text{Hz}$			0.9			*		$\text{pA}/\sqrt{\text{Hz}}$
$f = 1\text{kHz}$			0.3			*		$\text{pA}/\sqrt{\text{Hz}}$
$f_B = 0.1\text{Hz}$ to 10Hz			30			*		pAp-p
GAIN								
Gain Error	$V_O = \pm 13.6\text{V}$, $G = 100$		± 0.03	± 0.075		*	± 0.15	%
	$G = 10$		± 0.01	± 0.05		*	± 0.15	%
Gain vs Temperature ⁽²⁾	$G = 10, 100$		± 2	± 10		*	*	$\text{ppm}/^\circ\text{C}$
Nonlinearity	$G = 100$		± 0.0005	± 0.002		*	± 0.004	% of FSR
	$G = 10$		± 0.0003	± 0.001		*	± 0.002	% of FSR
OUTPUT								
Voltage: Positive	$R_L = 10\text{k}\Omega$	$(V+) - 1.4$	$(V+) - 0.9$		*	*		V
Negative	$R_L = 10\text{k}\Omega$	$(V-) + 1.4$	$(V-) + 0.9$		*	*		V
Load Capacitance Stability			1000			*		pF
Short-Circuit Current			+6/-15			*		mA
FREQUENCY RESPONSE								
Bandwidth, -3dB	$G = 100$		200			*		kHz
	$G = 10$		1			*		MHz
Slew Rate	$V_O = \pm 10\text{V}$, $G = 10$		4			*		$\text{V}/\mu\text{s}$
Settling Time, 0.01%	$V_O = \pm 5\text{V}$, $G = 100$		9			*		μs
	$G = 10$		7			*		μs
Overload Recovery	50% Overdrive		4			*		μs
POWER SUPPLY								
Voltage Range		± 2.25	± 15	± 18	*	*	*	V
Current, Total	$V_{IN} = 0\text{V}$		± 1.5	± 1.6		*	*	mA
TEMPERATURE RANGE								
Specification		-40		85	*		*	$^\circ\text{C}$
Operating		-40		125	*		*	$^\circ\text{C}$
θ_{JA}			80			*		$^\circ\text{C}/\text{W}$

* Specification same as INA2141P, U.

NOTE: (1) Input common-mode range varies with output voltage—see typical curves. (2) Guaranteed by wafer test.

The information provided herein is believed to be reliable; however, BURR-BROWN assumes no responsibility for inaccuracies or omissions. BURR-BROWN assumes no responsibility for the use of this information, and all use of such information shall be entirely at the user's own risk. Prices and specifications are subject to change without notice. No patent rights or licenses to any of the circuits described herein are implied or granted to any third party. BURR-BROWN does not authorize or warrant any BURR-BROWN product for use in life support devices and/or systems.

PIN CONFIGURATION

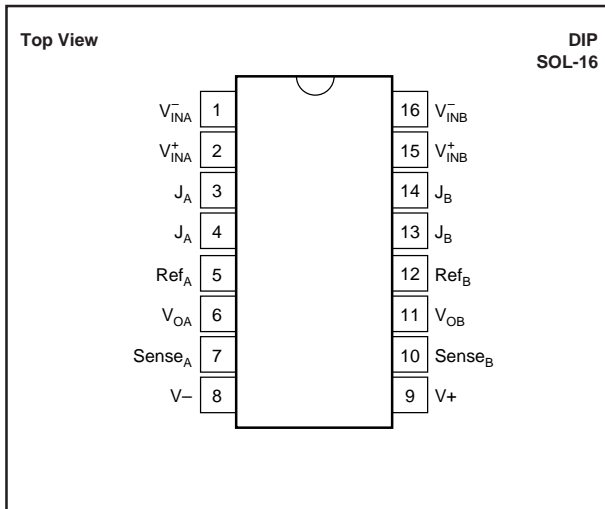

ABSOLUTE MAXIMUM RATINGS

Supply Voltage	$\pm 18V$
Analog Input Voltage Range	$\pm 40V$
Output Short-Circuit (to ground)	Continuous
Operating Temperature	$-40^\circ C$ to $+125^\circ C$
Storage Temperature	$-40^\circ C$ to $+125^\circ C$
Junction Temperature	$+150^\circ C$
Lead Temperature (soldering, 10s)	$+300^\circ C$

ELECTROSTATIC DISCHARGE SENSITIVITY

This integrated circuit can be damaged by ESD. Burr-Brown recommends that all integrated circuits be handled with appropriate precautions. Failure to observe proper handling and installation procedures can cause damage.

ESD damage can range from subtle performance degradation to complete device failure. Precision integrated circuits may be more susceptible to damage because very small parametric changes could cause the device not to meet its published specifications.

ORDERING INFORMATION

PRODUCT	PACKAGE	PACKAGE DRAWING NUMBER ⁽¹⁾	TEMPERATURE RANGE
INA2141PA	16-Pin Plastic DIP	180	$-40^\circ C$ to $+85^\circ C$
INA2141P	16-Pin Plastic DIP	180	$-40^\circ C$ to $+85^\circ C$
INA2141UA	SOL-16 Surface-Mount	211	$-40^\circ C$ to $+85^\circ C$
INA2141U	SOL-16 Surface-Mount	211	$-40^\circ C$ to $+85^\circ C$

NOTE: (1) For detailed drawing and dimension table, please see end of data sheet, or Appendix C of Burr-Brown IC Data Book.

TYPICAL PERFORMANCE CURVES

At $T_A = +25^\circ\text{C}$, and $V_S = \pm 15\text{V}$, unless otherwise noted.

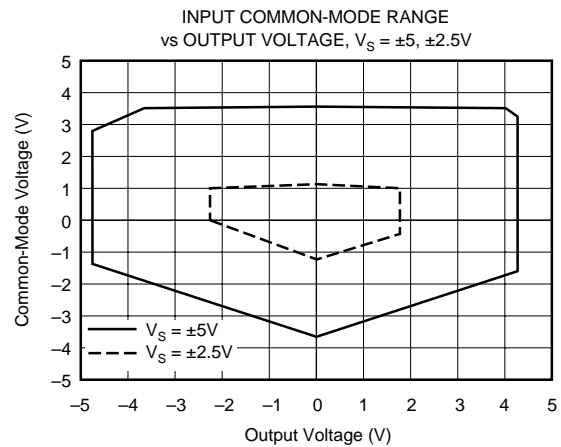
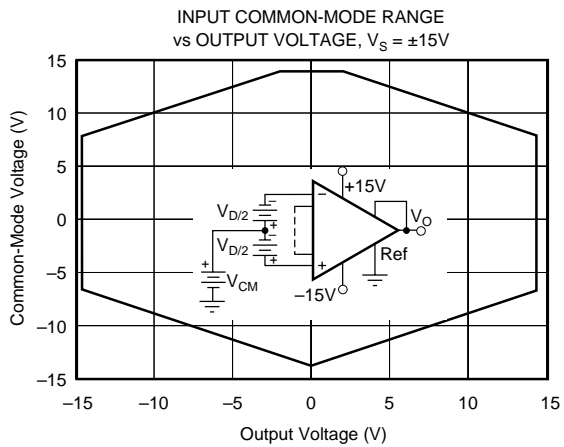
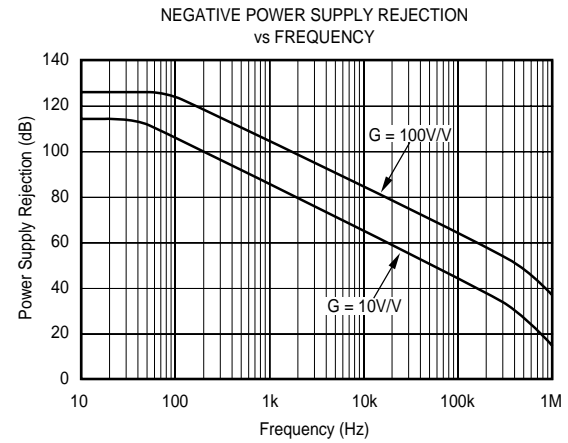
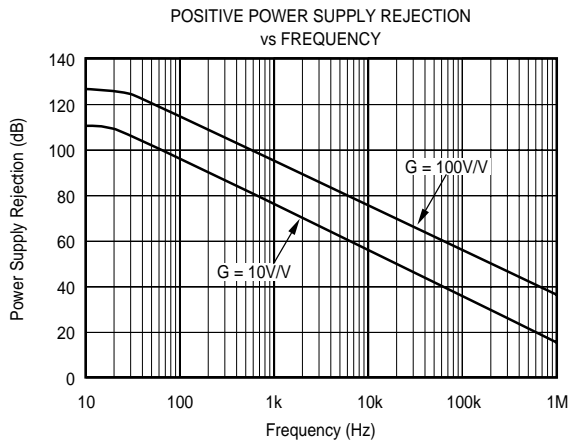
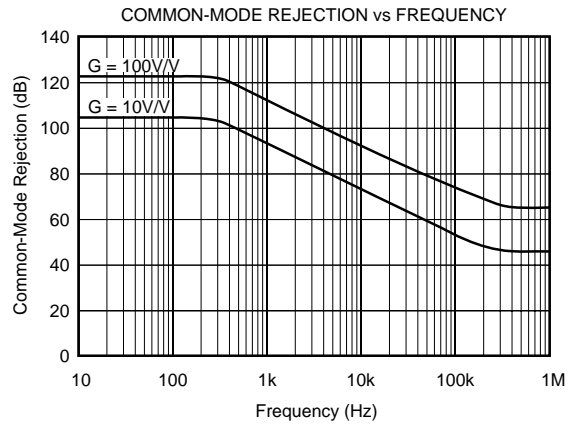
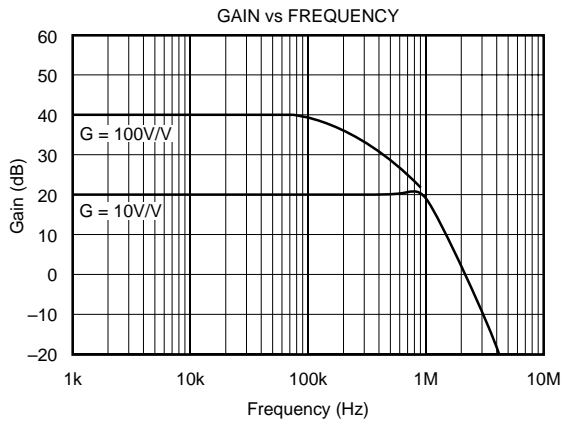

TYPICAL PERFORMANCE CURVES (CONT)

At $T_A = +25^\circ\text{C}$, and $V_S = \pm 15\text{V}$, unless otherwise noted.

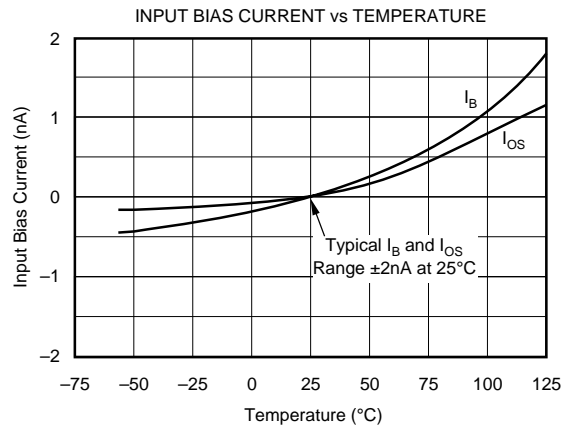
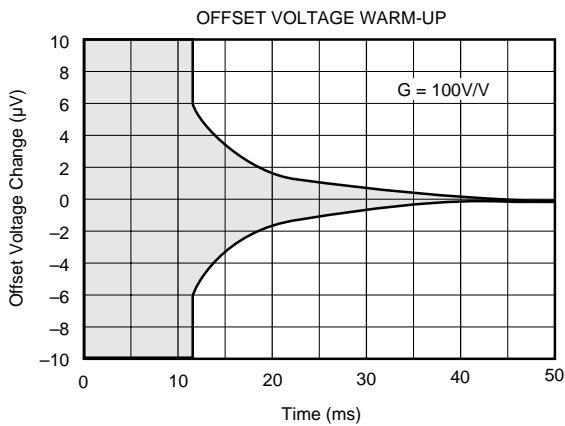
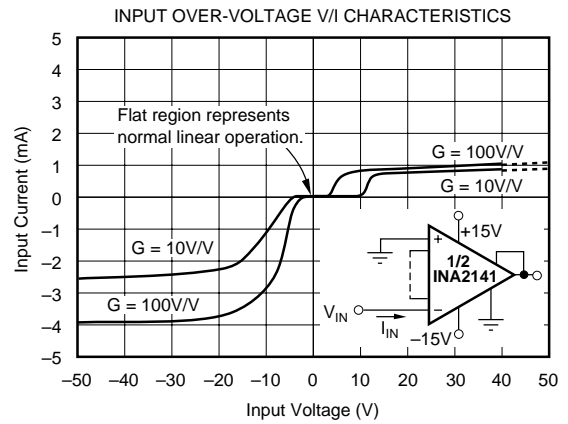
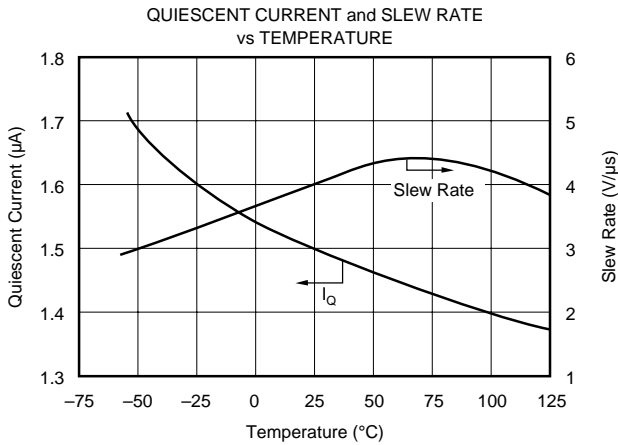
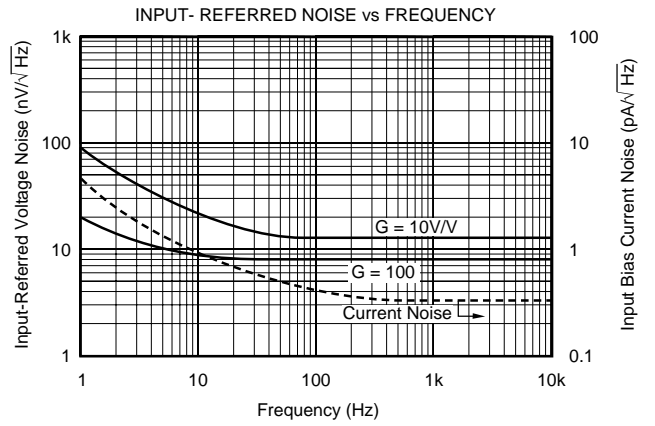
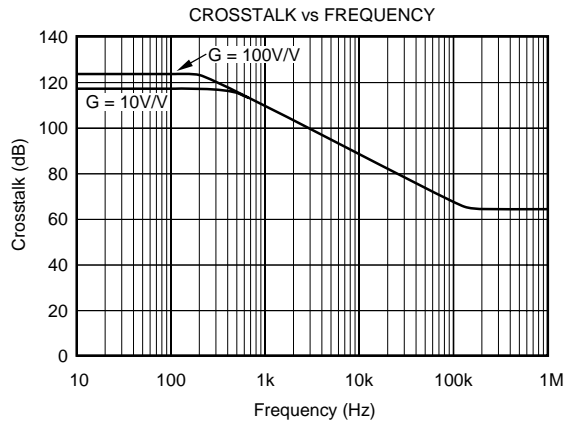

TYPICAL PERFORMANCE CURVES (CONT)

At $T_A = +25^\circ\text{C}$, and $V_S = \pm 15\text{V}$, unless otherwise noted.

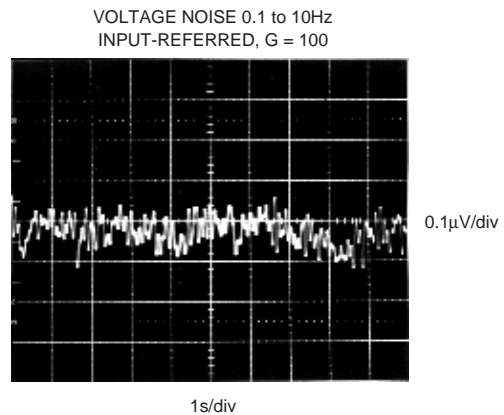
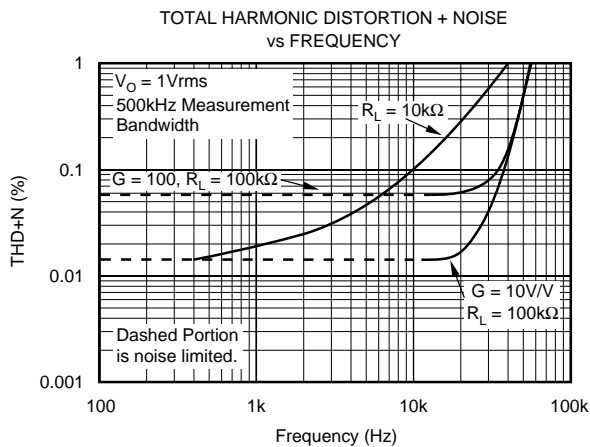
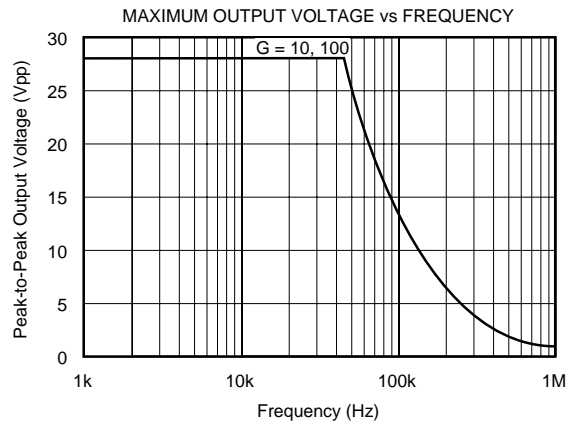
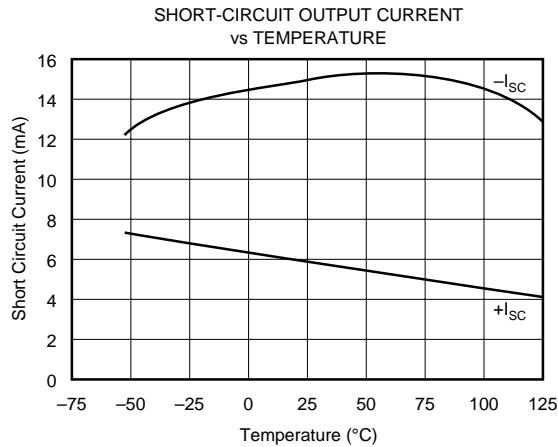
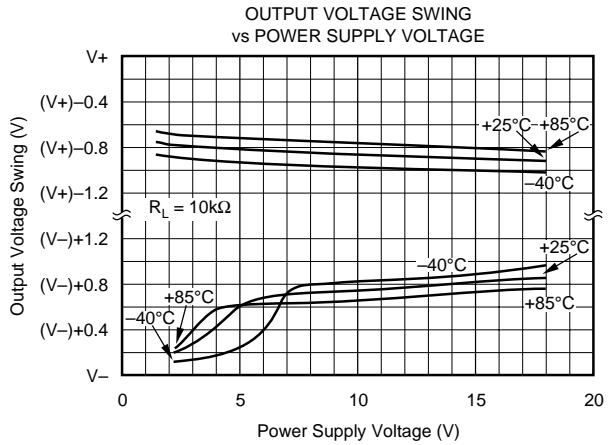
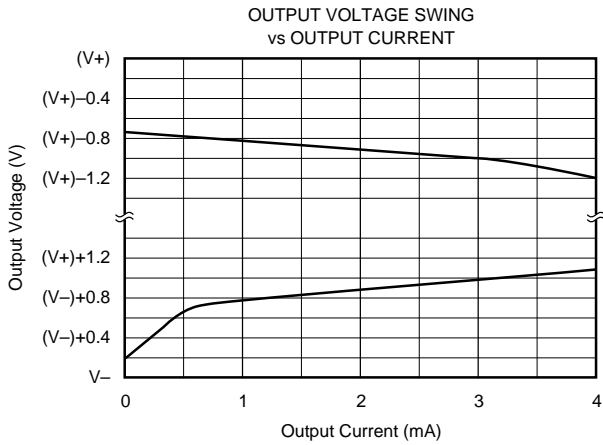

TYPICAL PERFORMANCE CURVES (CONT)

At $T_A = +25^\circ\text{C}$, and $V_S = \pm 15\text{V}$ unless otherwise noted.

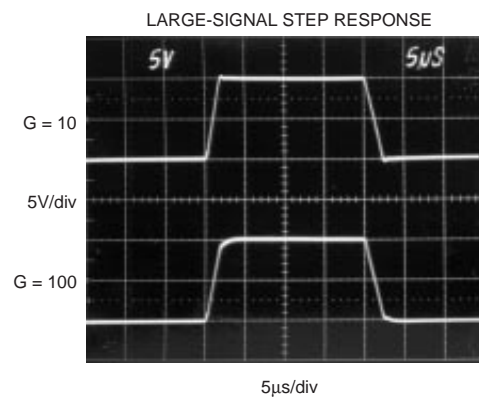
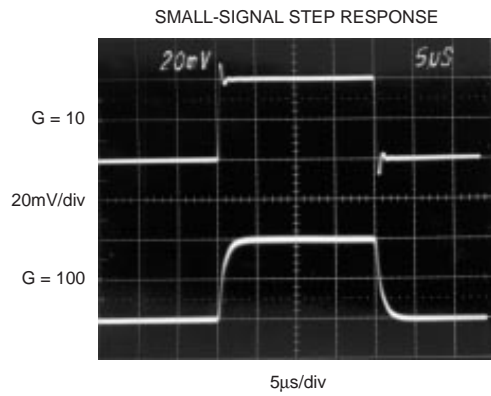

APPLICATION INFORMATION

Figure 1 shows the basic connections required for operation of the INA2141. Applications with noisy or high impedance power supplies may require decoupling capacitors close to the device pins as shown.

The output is referred to the output reference (Ref) terminals (Ref_A and Ref_B) which are normally grounded. These must be low-impedance connections to assure good common-mode rejection. A resistance of 8Ω in series with a Ref pin will cause a typical device to degrade to approximately 80dB CMR (G = 1).

The INA2141 has a separate output sense feedback connections Sense_A and Sense_B. These must be connected to their respective output terminals for proper operation. The output sense connection can be used to sense the output voltage directly at the load for best accuracy.

SETTING THE GAIN

Gain of each IA can be independently selected with a jumper connection as shown in Figure 1. G = 10V/V with no jumper installed. With a jumper installed G = 100V/V. To preserve good gain accuracy, this jumper must have low series resistance. A resistance of 0.5Ω in series with the jumper will decrease the gain by 0.1%.

Internal resistor ratios are laser trimmed to assure excellent gain accuracy. Actual resistor values can vary by approximately ±25% from the nominal values shown.

Gains between 10 and 100 can be achieved by connecting an external resistor to the jumper pins. This is not recommended, however, because the ±25% variation of internal resistor values makes the required external resistor value uncertain. A companion model, INA2128, features accurately trimmed internal resistors so that gains from 1 to 10,000 can be set with an external resistor.

DYNAMIC PERFORMANCE

The typical performance curve “Gain vs Frequency” shows that despite its low quiescent current, the INA2141 achieves wide bandwidth, even at high gain. This is due to its current-feedback topology. Settling time also remains excellent at high gain.

NOISE PERFORMANCE

The INA2141 provides very low noise in most applications. Low frequency noise is approximately 0.2μVp-p measured from 0.1 to 10Hz (G = 100). This provides dramatically improved noise when compared to state-of-the-art chopper-stabilized amplifiers.

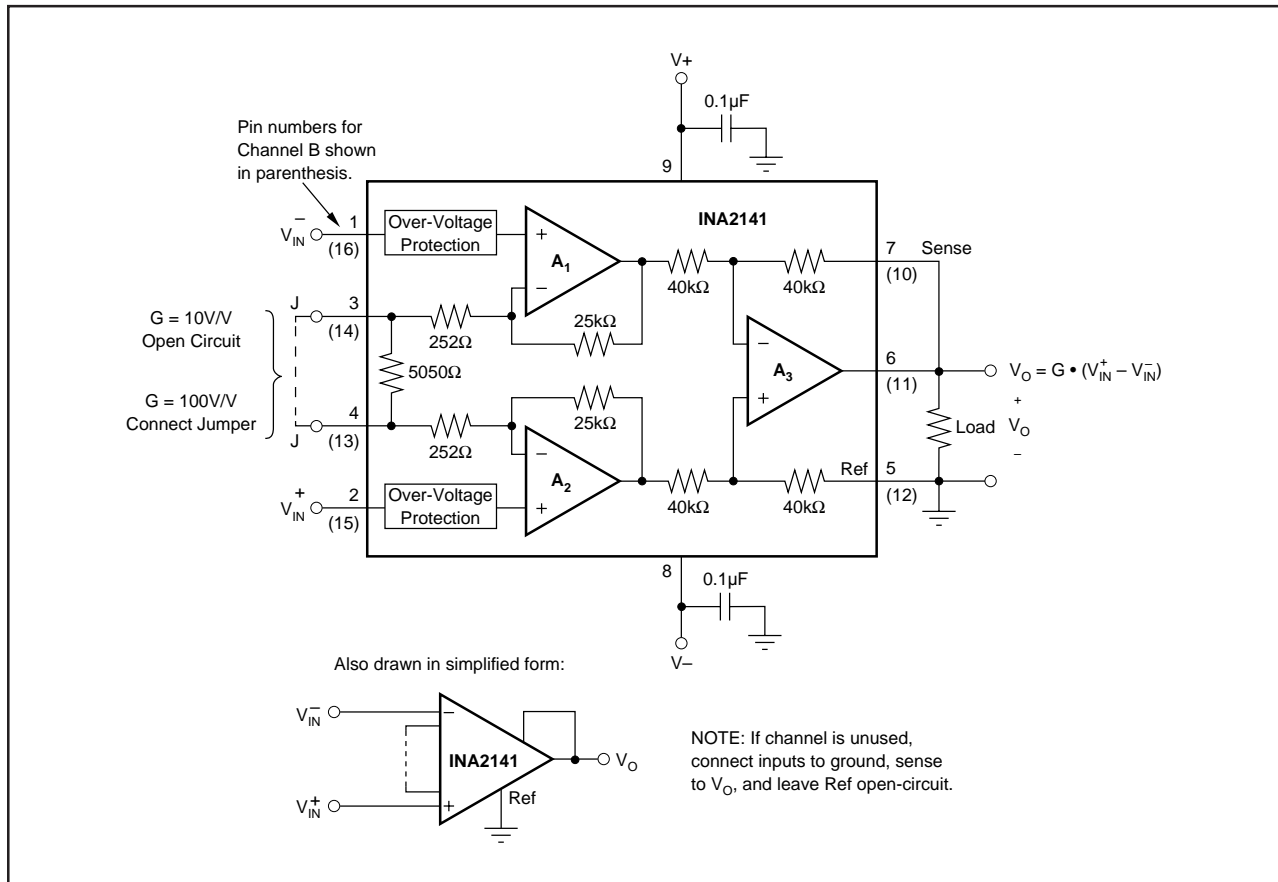

FIGURE 1. Basic Connections.

OFFSET TRIMMING

The INA2141 is laser trimmed for low offset voltage and offset voltage drift. Most applications require no external offset adjustment. Figure 2 shows an optional circuit for trimming the output offset voltage. The voltage applied to Ref terminal is summed with the output. The op amp buffer provides low impedance at the Ref terminal to preserve good common-mode rejection.

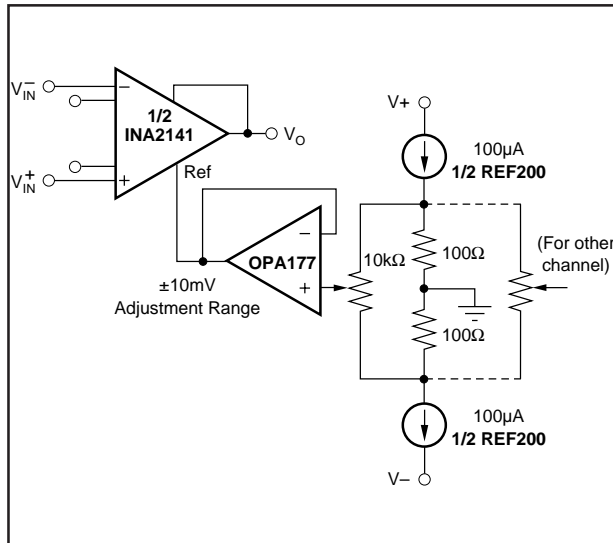

FIGURE 2. Optional Trimming of Output Offset Voltage.

INPUT BIAS CURRENT RETURN PATH

The input impedance of the INA2141 is extremely high—approximately $10^{10}\Omega$. However, a path must be provided for the input bias current of both inputs. This input bias current is approximately $\pm 2\text{nA}$. High input impedance means that this input bias current changes very little with varying input voltage.

Input circuitry must provide a path for this input bias current for proper operation. Figure 3 shows various provisions for an input bias current path. Without a bias current path, the inputs will float to a potential which exceeds the common-mode range of the INA2141 and the input amplifiers will saturate.

If the differential source resistance is low, the bias current return path can be connected to one input (see the thermocouple example in Figure 3). With higher source impedance, using two equal resistors provides a balanced input with possible advantages of lower input offset voltage due to bias current and better high-frequency common-mode rejection.

INPUT COMMON-MODE RANGE

The linear input voltage range of the input circuitry of the INA2141 is from approximately 1.4V below the positive supply voltage to 1.7V above the negative supply. As a differential input voltage causes the output voltage increase, however, the linear input range will be limited by the output voltage swing of amplifiers A_1 and A_2 . So the linear com-

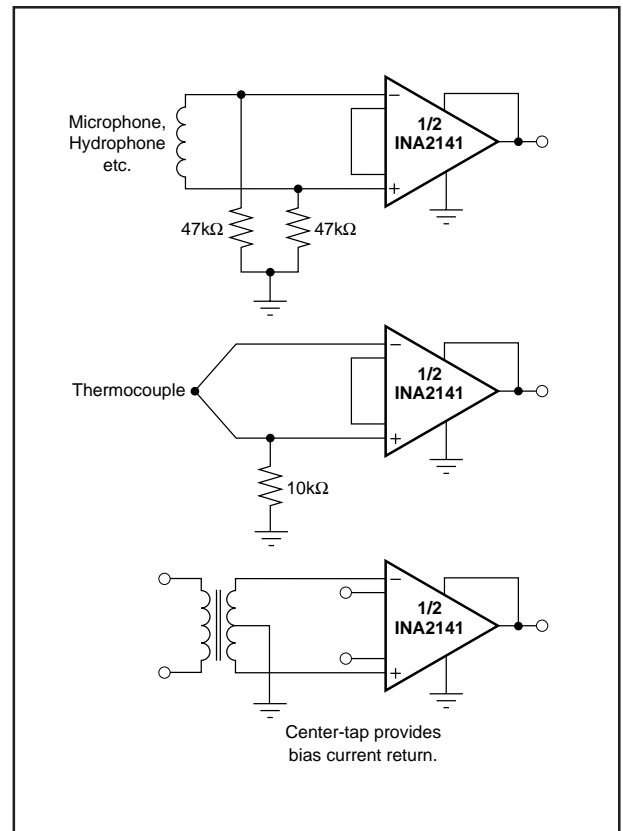

FIGURE 3. Providing an Input Common-Mode Current Path.

mon-mode input range is related to the output voltage of the complete amplifier. This behavior also depends on supply voltage—see performance curves “Input Common-Mode Range vs Output Voltage”.

Input-overload can produce an output voltage that appears normal. For example, if an input overload condition drives both input amplifiers to their positive output swing limit, the difference voltage measured by the output amplifier will be near zero. The output of the INA2141 will be near 0V even though both inputs are overloaded.

LOW VOLTAGE OPERATION

The INA2141 can be operated on power supplies as low as $\pm 2.25\text{V}$. Performance remains excellent with power supplies ranging from $\pm 2.25\text{V}$ to $\pm 18\text{V}$. Most parameters vary only slightly throughout this supply voltage range—see typical performance curves. Operation at very low supply voltage requires careful attention to assure that the input voltages remain within their linear range. Voltage swing requirements of internal nodes limit the input common-mode range with low power supply voltage. Typical performance curves, “Input Common-Mode Range vs Output Voltage” show the range of linear operation for $\pm 15\text{V}$, $\pm 5\text{V}$, and $\pm 2.5\text{V}$ supplies.

INPUT PROTECTION

The inputs of the INA2141 are individually protected for voltages up to $\pm 40\text{V}$. For example, a condition of -40V on one input and $+40\text{V}$ on the other input will not cause damage. Internal circuitry on each input provides low series impedance under normal signal conditions. To provide equivalent protection, series input resistors would contribute excessive noise. If the input is overloaded, the protection circuitry limits the input current to a safe value of approximately 1.5 to 5mA. The typical performance curve “Input Bias Current vs Common-Mode Input Voltage” shows this input current limit behavior. The inputs are protected even if the power supplies are disconnected or turned off.

CHANNEL CROSSTALK

The two channels of the INA2141 are completely independent, including all bias circuitry. At DC and low frequency

there is virtually no signal coupling between channels. Crosstalk increases with frequency and is dependent on circuit gain, source impedance and signal characteristics.

As source impedance increases, careful circuit layout will help achieve lowest channel crosstalk. Most crosstalk is produced by capacitive coupling of signals from one channel to the input section of the other channel. To minimize coupling, separate the input traces as far as practical from any signals associated with the opposite channel. A grounded guard trace surrounding the inputs helps reduce stray coupling between channels. Run the differential inputs of each channel parallel to each other or directly adjacent on top and bottom side of a circuit board. Stray coupling then tends to produce a common-mode signal which is rejected by the IA's input.

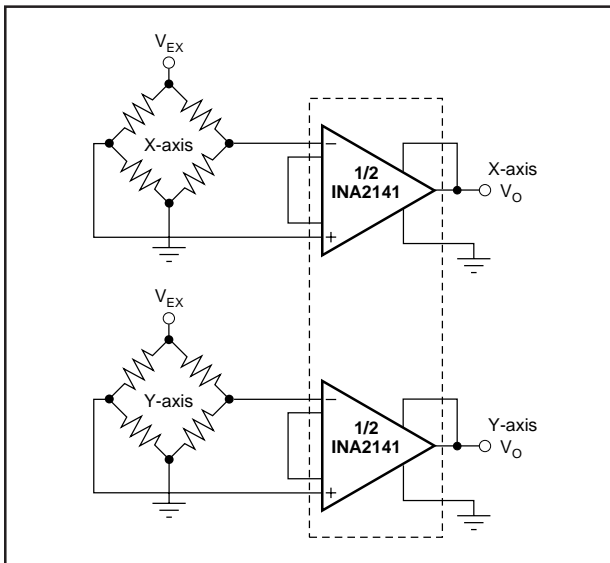

FIGURE 4. Two-Axis Bridge Amplifier.

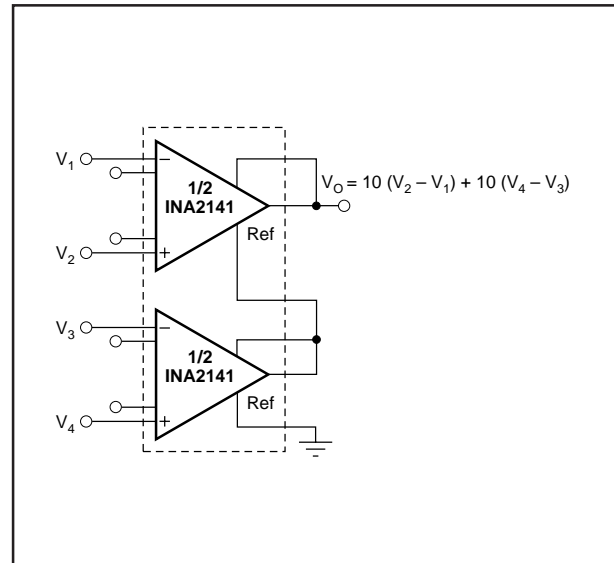

FIGURE 5. Sum of Differences Amplifier.

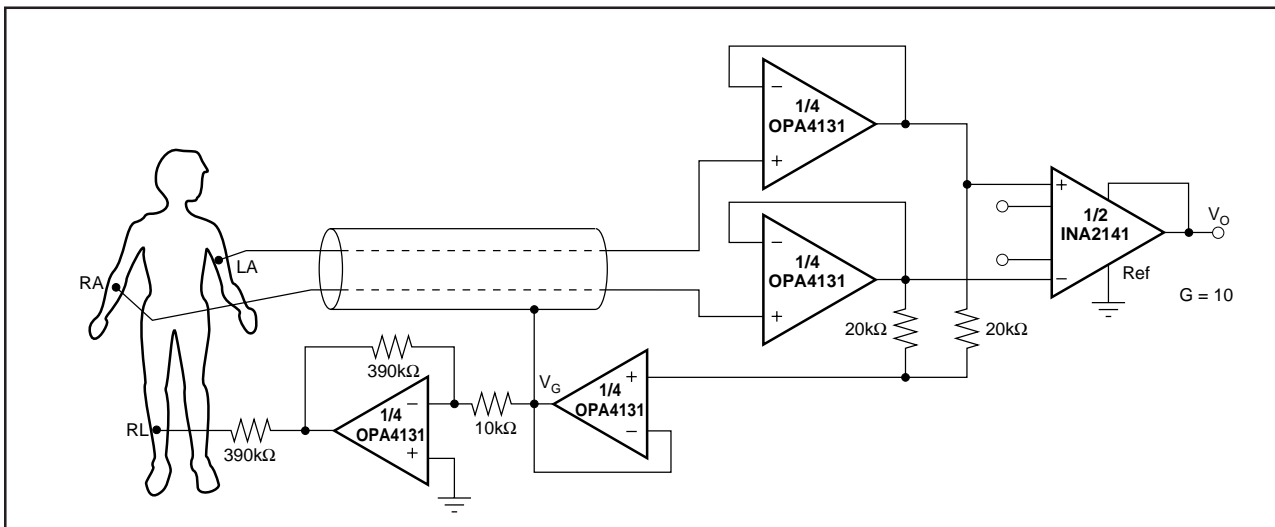

FIGURE 6. ECG Amplifier With Right-Leg Drive.

PACKAGING INFORMATION

Orderable Device	Status (1)	Package Type	Package Drawing	Pins	Package Qty	Eco Plan (2)	Lead/Ball Finish (6)	MSL Peak Temp (3)	Op Temp (°C)	Device Marking (4/5)	Samples
INA2141U	ACTIVE	SOIC	DW	16	40	Green (RoHS & no Sb/Br)	CU NIPDAU-DCC	Level-3-260C-168 HR	-40 to 85	INA2141U A	Samples
INA2141UA	ACTIVE	SOIC	DW	16	40	Green (RoHS & no Sb/Br)	CU NIPDAU-DCC	Level-3-260C-168 HR		INA2141U A	Samples
INA2141UA/1K	ACTIVE	SOIC	DW	16	1000	Green (RoHS & no Sb/Br)	CU NIPDAU-DCC	Level-3-260C-168 HR		INA2141U A	Samples
INA2141UE4	ACTIVE	SOIC	DW	16	40	Green (RoHS & no Sb/Br)	CU NIPDAU-DCC	Level-3-260C-168 HR	-40 to 85	INA2141U A	Samples

(1) The marketing status values are defined as follows:

ACTIVE: Product device recommended for new designs.

LIFEBUY: TI has announced that the device will be discontinued, and a lifetime-buy period is in effect.

NRND: Not recommended for new designs. Device is in production to support existing customers, but TI does not recommend using this part in a new design.

PREVIEW: Device has been announced but is not in production. Samples may or may not be available.

OBsolete: TI has discontinued the production of the device.

(2) **RoHS:** TI defines "RoHS" to mean semiconductor products that are compliant with the current EU RoHS requirements for all 10 RoHS substances, including the requirement that RoHS substance do not exceed 0.1% by weight in homogeneous materials. Where designed to be soldered at high temperatures, "RoHS" products are suitable for use in specified lead-free processes. TI may reference these types of products as "Pb-Free".

RoHS Exempt: TI defines "RoHS Exempt" to mean products that contain lead but are compliant with EU RoHS pursuant to a specific EU RoHS exemption.

Green: TI defines "Green" to mean the content of Chlorine (Cl) and Bromine (Br) based flame retardants meet JS709B low halogen requirements of <=1000ppm threshold. Antimony trioxide based flame retardants must also meet the <=1000ppm threshold requirement.

(3) MSL, Peak Temp. - The Moisture Sensitivity Level rating according to the JEDEC industry standard classifications, and peak solder temperature.

(4) There may be additional marking, which relates to the logo, the lot trace code information, or the environmental category on the device.

(5) Multiple Device Markings will be inside parentheses. Only one Device Marking contained in parentheses and separated by a "-" will appear on a device. If a line is indented then it is a continuation of the previous line and the two combined represent the entire Device Marking for that device.

(6) Lead/Ball Finish - Orderable Devices may have multiple material finish options. Finish options are separated by a vertical ruled line. Lead/Ball Finish values may wrap to two lines if the finish value exceeds the maximum column width.

Important Information and Disclaimer:The information provided on this page represents TI's knowledge and belief as of the date that it is provided. TI bases its knowledge and belief on information provided by third parties, and makes no representation or warranty as to the accuracy of such information. Efforts are underway to better integrate information from third parties. TI has taken and

continues to take reasonable steps to provide representative and accurate information but may not have conducted destructive testing or chemical analysis on incoming materials and chemicals. TI and TI suppliers consider certain information to be proprietary, and thus CAS numbers and other limited information may not be available for release.

In no event shall TI's liability arising out of such information exceed the total purchase price of the TI part(s) at issue in this document sold by TI to Customer on an annual basis.

TAPE AND REEL INFORMATION

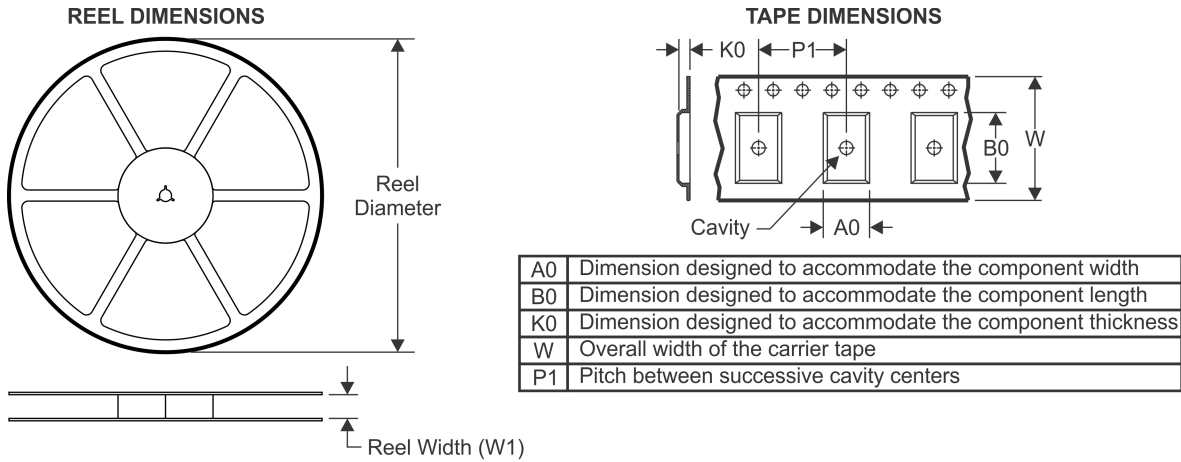

QUADRANT ASSIGNMENTS FOR PIN 1 ORIENTATION IN TAPE



*All dimensions are nominal

Device	Package Type	Package Drawing	Pins	SPQ	Reel Diameter (mm)	Reel Width W1 (mm)	A0 (mm)	B0 (mm)	K0 (mm)	P1 (mm)	W (mm)	Pin1 Quadrant
INA2141UA/1K	SOIC	DW	16	1000	330.0	16.4	10.75	10.7	2.7	12.0	16.0	Q1

TAPE AND REEL BOX DIMENSIONS



*All dimensions are nominal

Device	Package Type	Package Drawing	Pins	SPQ	Length (mm)	Width (mm)	Height (mm)
INA2141UA/1K	SOIC	DW	16	1000	367.0	367.0	38.0

IMPORTANT NOTICE

Texas Instruments Incorporated (TI) reserves the right to make corrections, enhancements, improvements and other changes to its semiconductor products and services per JESD46, latest issue, and to discontinue any product or service per JESD48, latest issue. Buyers should obtain the latest relevant information before placing orders and should verify that such information is current and complete.

TI's published terms of sale for semiconductor products (<http://www.ti.com/sc/docs/stdterms.htm>) apply to the sale of packaged integrated circuit products that TI has qualified and released to market. Additional terms may apply to the use or sale of other types of TI products and services.

Reproduction of significant portions of TI information in TI data sheets is permissible only if reproduction is without alteration and is accompanied by all associated warranties, conditions, limitations, and notices. TI is not responsible or liable for such reproduced documentation. Information of third parties may be subject to additional restrictions. Resale of TI products or services with statements different from or beyond the parameters stated by TI for that product or service voids all express and any implied warranties for the associated TI product or service and is an unfair and deceptive business practice. TI is not responsible or liable for any such statements.

Buyers and others who are developing systems that incorporate TI products (collectively, "Designers") understand and agree that Designers remain responsible for using their independent analysis, evaluation and judgment in designing their applications and that Designers have full and exclusive responsibility to assure the safety of Designers' applications and compliance of their applications (and of all TI products used in or for Designers' applications) with all applicable regulations, laws and other applicable requirements. Designer represents that, with respect to their applications, Designer has all the necessary expertise to create and implement safeguards that (1) anticipate dangerous consequences of failures, (2) monitor failures and their consequences, and (3) lessen the likelihood of failures that might cause harm and take appropriate actions. Designer agrees that prior to using or distributing any applications that include TI products, Designer will thoroughly test such applications and the functionality of such TI products as used in such applications.

TI's provision of technical, application or other design advice, quality characterization, reliability data or other services or information, including, but not limited to, reference designs and materials relating to evaluation modules, (collectively, "TI Resources") are intended to assist designers who are developing applications that incorporate TI products; by downloading, accessing or using TI Resources in any way, Designer (individually or, if Designer is acting on behalf of a company, Designer's company) agrees to use any particular TI Resource solely for this purpose and subject to the terms of this Notice.

TI's provision of TI Resources does not expand or otherwise alter TI's applicable published warranties or warranty disclaimers for TI products, and no additional obligations or liabilities arise from TI providing such TI Resources. TI reserves the right to make corrections, enhancements, improvements and other changes to its TI Resources. TI has not conducted any testing other than that specifically described in the published documentation for a particular TI Resource.

Designer is authorized to use, copy and modify any individual TI Resource only in connection with the development of applications that include the TI product(s) identified in such TI Resource. NO OTHER LICENSE, EXPRESS OR IMPLIED, BY ESTOPPEL OR OTHERWISE TO ANY OTHER TI INTELLECTUAL PROPERTY RIGHT, AND NO LICENSE TO ANY TECHNOLOGY OR INTELLECTUAL PROPERTY RIGHT OF TI OR ANY THIRD PARTY IS GRANTED HEREIN, including but not limited to any patent right, copyright, mask work right, or other intellectual property right relating to any combination, machine, or process in which TI products or services are used. Information regarding or referencing third-party products or services does not constitute a license to use such products or services, or a warranty or endorsement thereof. Use of TI Resources may require a license from a third party under the patents or other intellectual property of the third party, or a license from TI under the patents or other intellectual property of TI.

TI RESOURCES ARE PROVIDED "AS IS" AND WITH ALL FAULTS. TI DISCLAIMS ALL OTHER WARRANTIES OR REPRESENTATIONS, EXPRESS OR IMPLIED, REGARDING RESOURCES OR USE THEREOF, INCLUDING BUT NOT LIMITED TO ACCURACY OR COMPLETENESS, TITLE, ANY EPIDEMIC FAILURE WARRANTY AND ANY IMPLIED WARRANTIES OF MERCHANTABILITY, FITNESS FOR A PARTICULAR PURPOSE, AND NON-INFRINGEMENT OF ANY THIRD PARTY INTELLECTUAL PROPERTY RIGHTS. TI SHALL NOT BE LIABLE FOR AND SHALL NOT DEFEND OR INDEMNIFY DESIGNER AGAINST ANY CLAIM, INCLUDING BUT NOT LIMITED TO ANY INFRINGEMENT CLAIM THAT RELATES TO OR IS BASED ON ANY COMBINATION OF PRODUCTS EVEN IF DESCRIBED IN TI RESOURCES OR OTHERWISE. IN NO EVENT SHALL TI BE LIABLE FOR ANY ACTUAL, DIRECT, SPECIAL, COLLATERAL, INDIRECT, PUNITIVE, INCIDENTAL, CONSEQUENTIAL OR EXEMPLARY DAMAGES IN CONNECTION WITH OR ARISING OUT OF TI RESOURCES OR USE THEREOF, AND REGARDLESS OF WHETHER TI HAS BEEN ADVISED OF THE POSSIBILITY OF SUCH DAMAGES.

Unless TI has explicitly designated an individual product as meeting the requirements of a particular industry standard (e.g., ISO/TS 16949 and ISO 26262), TI is not responsible for any failure to meet such industry standard requirements.

Where TI specifically promotes products as facilitating functional safety or as compliant with industry functional safety standards, such products are intended to help enable customers to design and create their own applications that meet applicable functional safety standards and requirements. Using products in an application does not by itself establish any safety features in the application. Designers must ensure compliance with safety-related requirements and standards applicable to their applications. Designer may not use any TI products in life-critical medical equipment unless authorized officers of the parties have executed a special contract specifically governing such use. Life-critical medical equipment is medical equipment where failure of such equipment would cause serious bodily injury or death (e.g., life support, pacemakers, defibrillators, heart pumps, neurostimulators, and implantables). Such equipment includes, without limitation, all medical devices identified by the U.S. Food and Drug Administration as Class III devices and equivalent classifications outside the U.S.

TI may expressly designate certain products as completing a particular qualification (e.g., Q100, Military Grade, or Enhanced Product). Designers agree that it has the necessary expertise to select the product with the appropriate qualification designation for their applications and that proper product selection is at Designers' own risk. Designers are solely responsible for compliance with all legal and regulatory requirements in connection with such selection.

Designer will fully indemnify TI and its representatives against any damages, costs, losses, and/or liabilities arising out of Designer's non-compliance with the terms and provisions of this Notice.

Looking for pricing, stock, or lifecycle information?

Click below to explore more details on WIN SOURCE:

 [View INA2141UA](#) on WIN SOURCE

 [Texas Instruments](#) Information

Optimize Your Supply Chain with WIN SOURCE Solutions

-  Global Sourcing Solution
-  Obsolete Management
-  Cost Control Management
-  Shortage Management
-  Alternative Solution
-  Excess Inventory Management