

INA134 INA2134

AUDIO DIFFERENTIAL LINE RECEIVERS 0dB (G = 1)

FEATURES

- SINGLE AND DUAL VERSIONS
- LOW DISTORTION: 0.0005% at $f = 1\text{kHz}$
- HIGH SLEW RATE: $14\text{V}/\mu\text{s}$
- FAST SETTLING TIME: $3\mu\text{s}$ to 0.01%
- WIDE SUPPLY RANGE: $\pm 4\text{V}$ to $\pm 18\text{V}$
- LOW QUIESCIENT CURRENT: 2.9mA max
- HIGH CMRR: 90dB
- FIXED GAIN = 0dB (1V/V)
- PACKAGES—SINGLE: 8-PIN DIP, SO-8
DUAL: 14-PIN DIP, SO-14

DESCRIPTION

The INA134 and INA2134 are differential line receivers consisting of high performance op amps with on-chip precision resistors. They are fully specified for high performance audio applications and have excellent ac specifications, including low distortion (0.0005% at 1kHz) and high slew rate ($14\text{V}/\mu\text{s}$), assuring good dynamic response. In addition, wide output voltage swing and high output drive capability allow use in a wide variety of demanding applications. The dual version features completely independent circuitry for lowest crosstalk and freedom from interaction, even when overdriven or overloaded.

The INA134 and INA2134 on-chip resistors are laser trimmed for accurate gain and optimum common-mode rejection. Furthermore, excellent TCR tracking of the resistors maintains gain accuracy and common-mode rejection over temperature. Operation is guaranteed from $\pm 4\text{V}$ to $\pm 18\text{V}$ (8V to 36V total supply).

The INA134 is available in 8-pin DIP and SO-8 surface-mount packages. The INA2134 comes in 14-pin DIP and SO-14 surface-mount packages. Both are specified for operation over the extended industrial temperature range, -40°C to $+85^\circ\text{C}$.

APPLICATIONS

- AUDIO DIFFERENTIAL LINE RECEIVER
- SUMMING AMPLIFIER
- UNITY-GAIN INVERTING AMPLIFIER
- PSEUDOGROUND GENERATOR
- INSTRUMENTATION BUILDING BLOCK
- CURRENT SHUNT MONITOR
- VOLTAGE-CONTROLLED CURRENT SOURCE
- GROUND LOOP ELIMINATOR

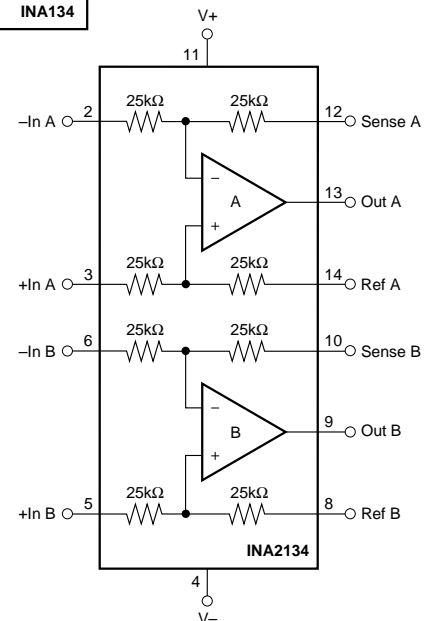
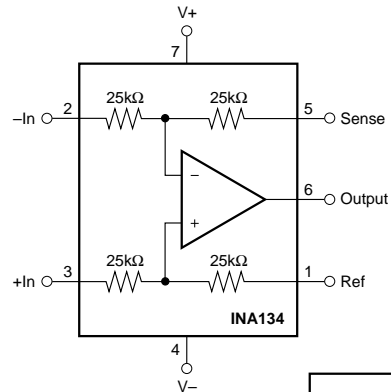

SPECIFICATIONS: $V_S = \pm 18V$

At $T_A = +25^\circ C$, $V_S = \pm 18V$, $R_L = 2k\Omega$, and Ref Pin connected to Ground, unless otherwise noted.

PARAMETER	CONDITIONS	INA134PA, UA INA2134PA, UA			UNITS
		MIN	TYP	MAX	
AUDIO PERFORMANCE Total Harmonic Distortion + Noise, $f = 1kHz$ Noise Floor ⁽¹⁾ Headroom ⁽¹⁾	$V_{IN} = 10V_{rms}$ 20kHz BW THD+N < 1%		0.0005 -100 +23		% dBu dBu
FREQUENCY RESPONSE Small-Signal Bandwidth Slew Rate Settling Time: 0.1% 0.01% Overload Recovery Time Channel Separation (dual), $f = 1kHz$	10V Step, $C_L = 100pF$ 10V Step, $C_L = 100pF$ 50% Overdrive		3.1 14 2 3 3 117		MHz V/ μs μs μs μs dB
OUTPUT NOISE VOLTAGE⁽²⁾ $f = 20Hz$ to 20kHz $f = 1kHz$			7 52		μV_{rms} nV/ \sqrt{Hz}
OFFSET VOLTAGE⁽³⁾ Input Offset Voltage vs Temperature vs Power Supply	$V_{CM} = 0V$ Specified Temperature Range $V_S = \pm 4V$ to $\pm 18V$		± 100 ± 2 ± 5	± 1000 ± 60	μV $\mu V/^\circ C$ $\mu V/V$
INPUT Common-Mode Voltage Range: Positive Negative Differential Voltage Range Common-Mode Rejection Impedance ⁽⁴⁾ Differential Common-Mode	$V_O = 0V$ $V_O = 0V$ $V_{CM} = \pm 31V$, $R_S = 0\Omega$	2(V+)-5 2(V-)+5 74	2(V+)-4 2(V-)+2 See Typical Curve 90 50 50		V V dB k Ω k Ω
GAIN Initial Error vs Temperature Nonlinearity	$V_O = -16V$ to 16V $V_O = -16V$ to 16V		1 ± 0.02 ± 1 0.0001	± 0.1 ± 10	V/V % ppm/ $^\circ C$ %
OUTPUT Voltage Output, Positive Negative Current Limit, Continuous to Common Capacitive Load (Stable Operation)		(V+)-2 (V-)+2	(V+)-1.8 (V-)+1.6 ± 60 500		V V mA pF
POWER SUPPLY Rated Voltage Voltage Range Quiescent Current (per Amplifier)	$I_O = 0$	± 4	± 18 ± 2.4	± 18 ± 2.9	V V mA
TEMPERATURE RANGE Specification Range Operation Range Storage Range Thermal Resistance, θ_{JA} 8-Pin DIP SO-8 Surface-Mount 14-Pin DIP SO-14 Surface-Mount		-40 -55 -55		85 125 125	$^\circ C$ $^\circ C$ $^\circ C$ $^\circ C/W$ $^\circ C/W$ $^\circ C/W$ $^\circ C/W$

NOTES: (1) dBu = 20log (Vrms/0.7746). (2) Includes effects of amplifier's input current noise and thermal noise contribution of resistor network. (3) Includes effects of amplifier's input bias and offset currents. (4) 25k Ω resistors are ratio matched but have $\pm 25\%$ absolute value.

The information provided herein is believed to be reliable; however, BURR-BROWN assumes no responsibility for inaccuracies or omissions. BURR-BROWN assumes no responsibility for the use of this information, and all use of such information shall be entirely at the user's own risk. Prices and specifications are subject to change without notice. No patent rights or licenses to any of the circuits described herein are implied or granted to any third party. BURR-BROWN does not authorize or warrant any BURR-BROWN product for use in life support devices and/or systems.

PIN CONFIGURATIONS

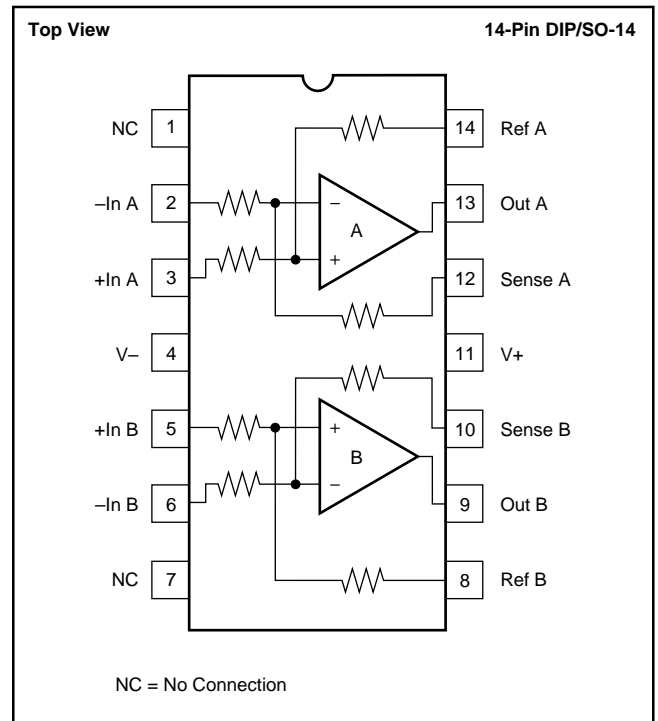
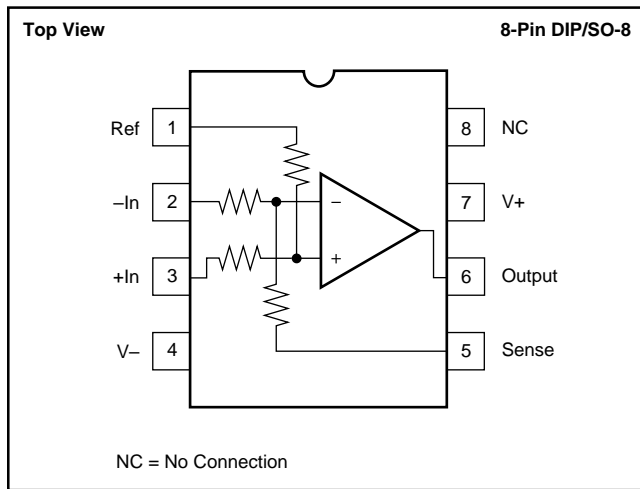

ABSOLUTE MAXIMUM RATINGS⁽¹⁾

Supply Voltage, V+ to V-	40V
Input Voltage Range	±80V
Output Short-Circuit (to ground) ⁽²⁾	Continuous
Operating Temperature	-55°C to +125°C
Storage Temperature	-55°C to +125°C
Junction Temperature	+150°C
Lead Temperature (soldering, 10s)	+300°C

NOTE: (1) Stresses above these ratings may cause permanent damage.
 (2) One channel per package.

PACKAGE/ORDERING INFORMATION

PRODUCT	PACKAGE	PACKAGE DRAWING NUMBER ⁽¹⁾	SPECIFICATION TEMPERATURE RANGE
Single			
INA134PA	8-Pin DIP	006	-40°C to +85°C
INA134UA	SO-8 Surface-Mount	182	-40°C to +85°C
Dual			
INA2134PA	14-Pin DIP	010	-40°C to +85°C
INA2134UA	SO-14 Surface-Mount	235	-40°C to +85°C

NOTE: (1) For detailed drawing and dimension table, please see end of data sheet, or Appendix C of Burr-Brown IC Data Book.



ELECTROSTATIC DISCHARGE SENSITIVITY

This integrated circuit can be damaged by ESD. Burr-Brown recommends that all integrated circuits be handled with appropriate precautions. Failure to observe proper handling and installation procedures can cause damage.

ESD damage can range from subtle performance degradation to complete device failure. Precision integrated circuits may be more susceptible to damage because very small parametric changes could cause the device not to meet its published specifications.

TYPICAL PERFORMANCE CURVES

At $T_A = +25^\circ\text{C}$, $V_S = \pm 18\text{V}$, unless otherwise noted.

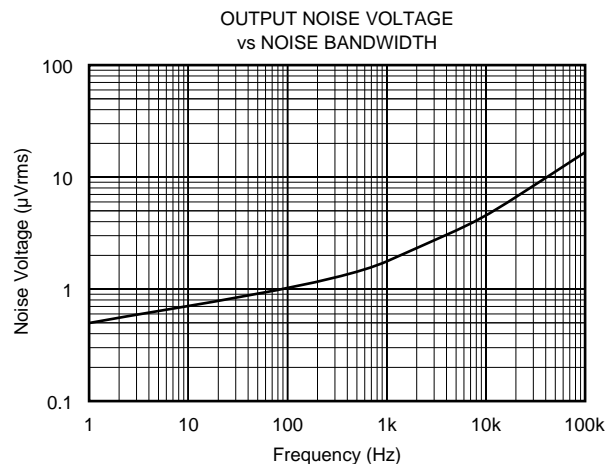
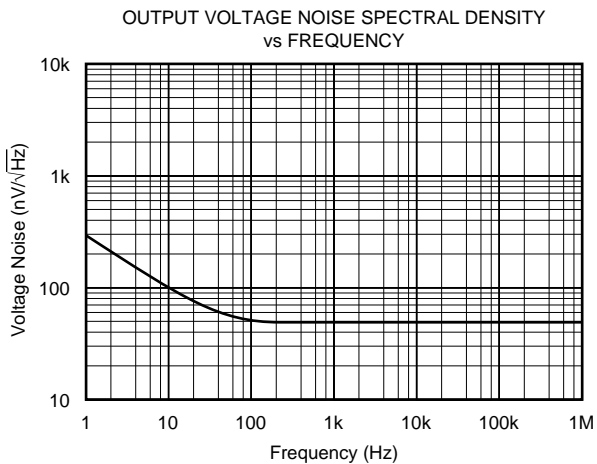
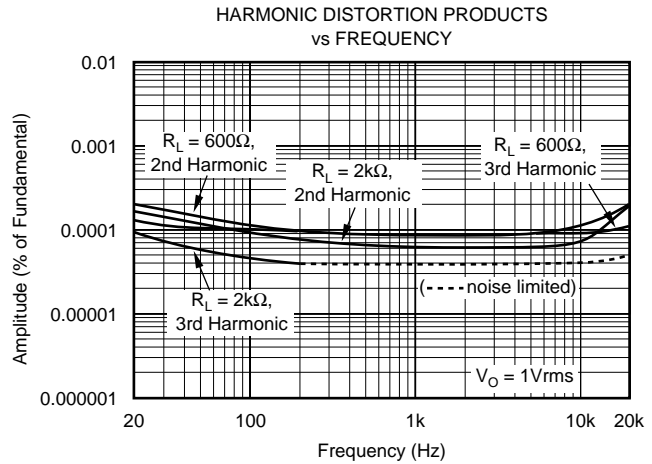
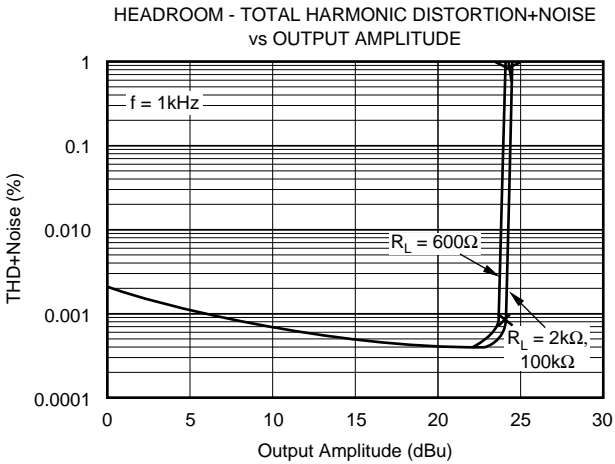
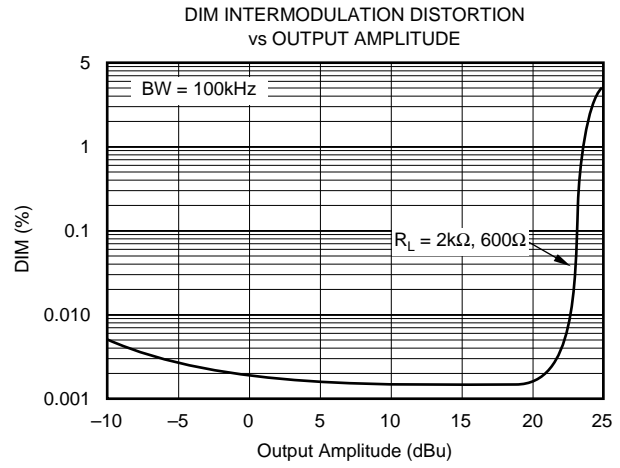
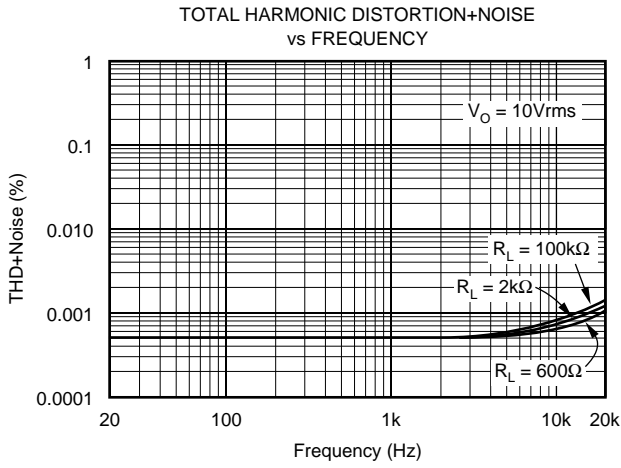

TYPICAL PERFORMANCE CURVES (CONT)

At $T_A = +25^\circ\text{C}$, $V_S = \pm 18\text{V}$, unless otherwise noted.

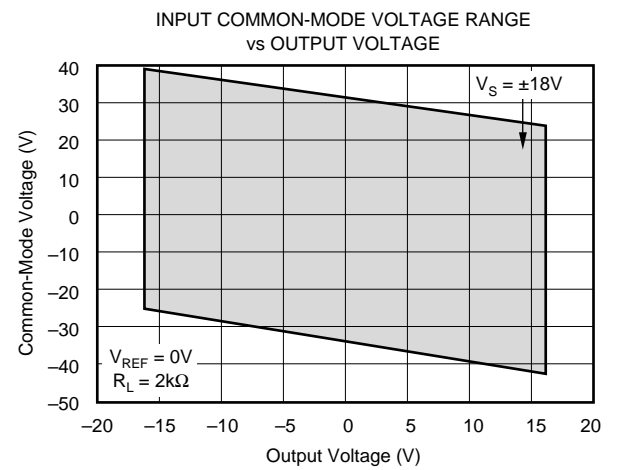
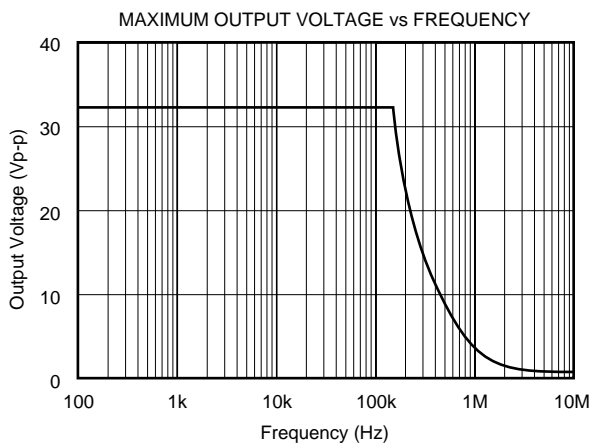
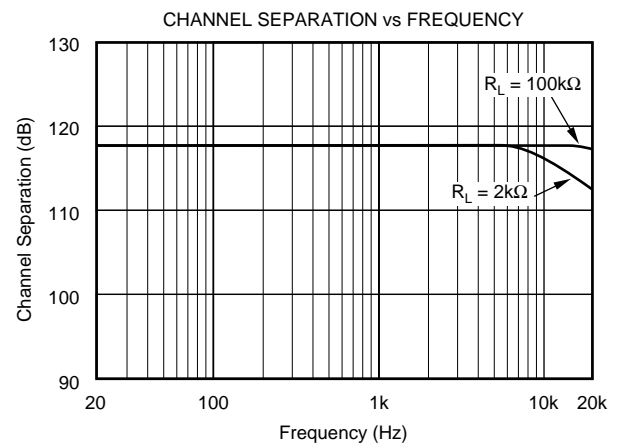
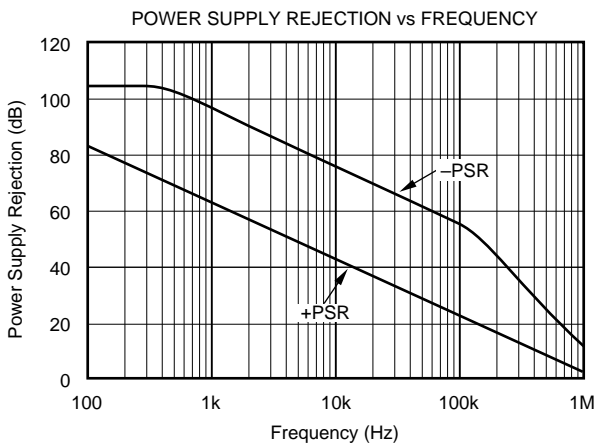
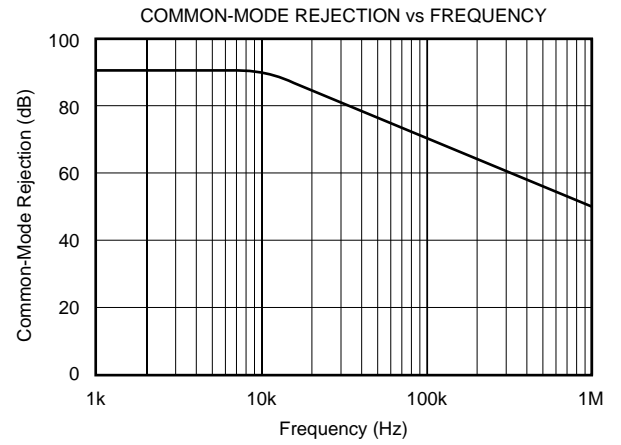
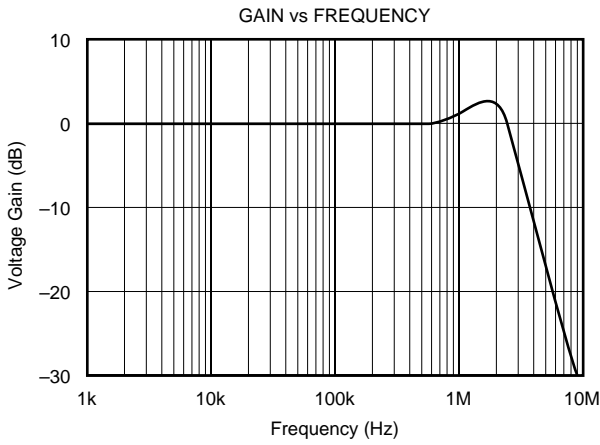

TYPICAL PERFORMANCE CURVES (CONT)

At $T_A = +25^\circ\text{C}$, $V_S = \pm 18\text{V}$, unless otherwise noted.

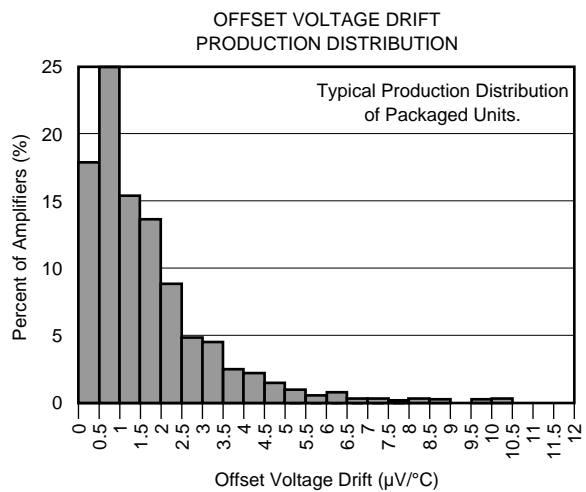
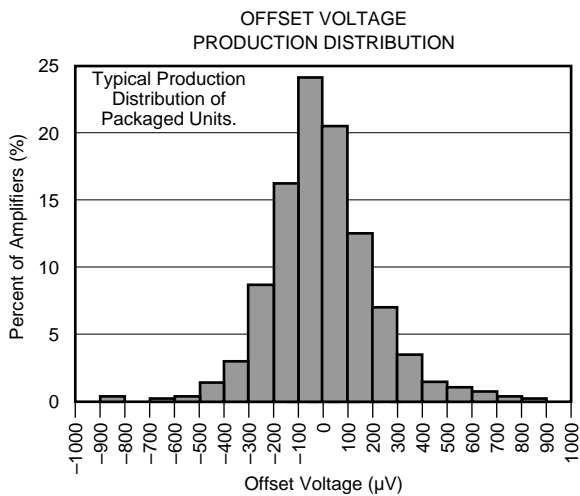
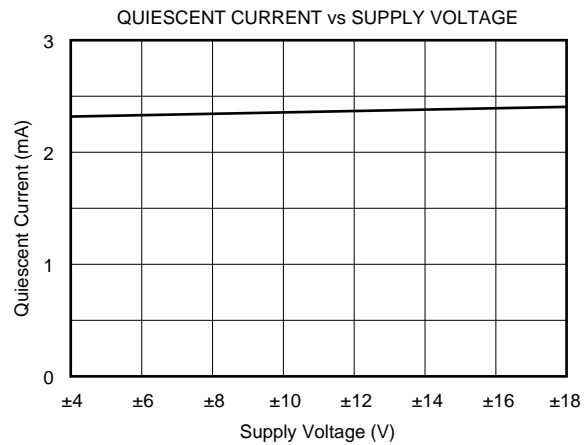
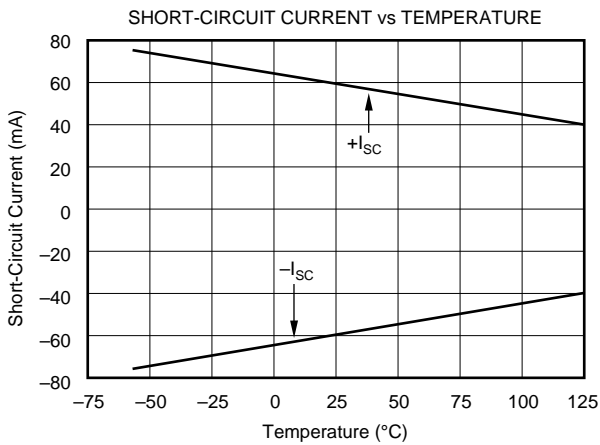
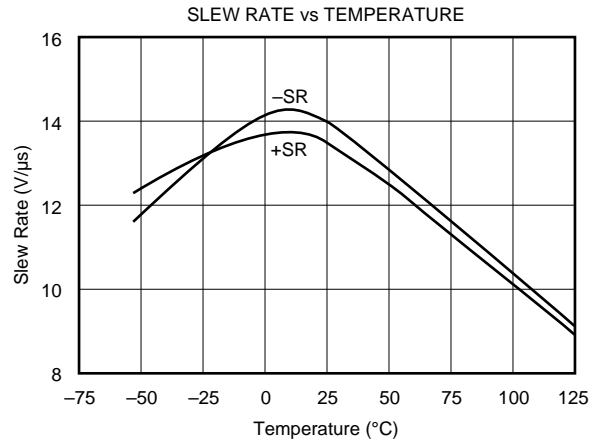
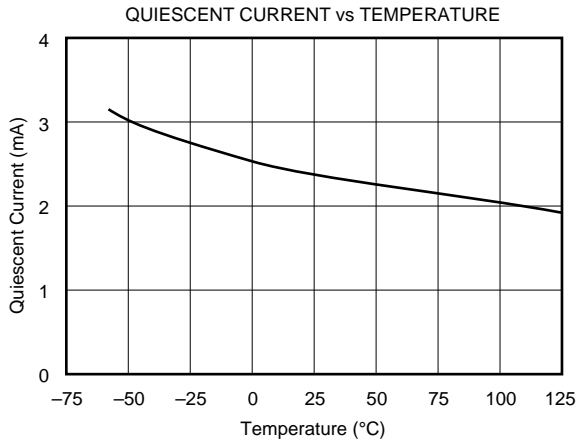

TYPICAL PERFORMANCE CURVES (CONT)

At $T_A = +25^\circ\text{C}$, $V_S = \pm 18\text{V}$, unless otherwise noted.

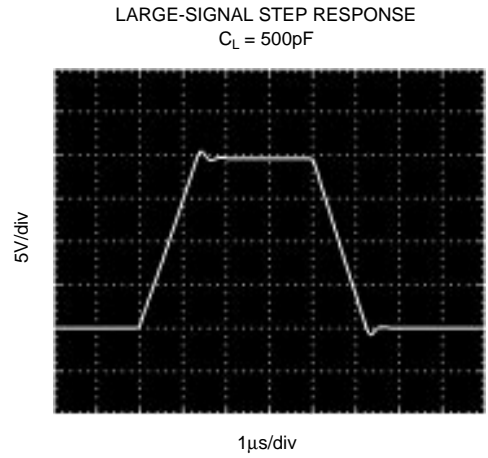
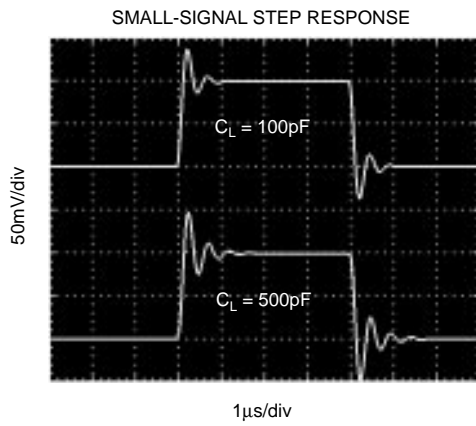
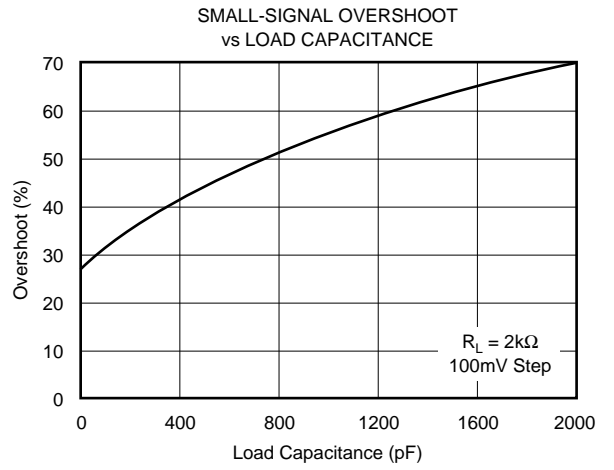
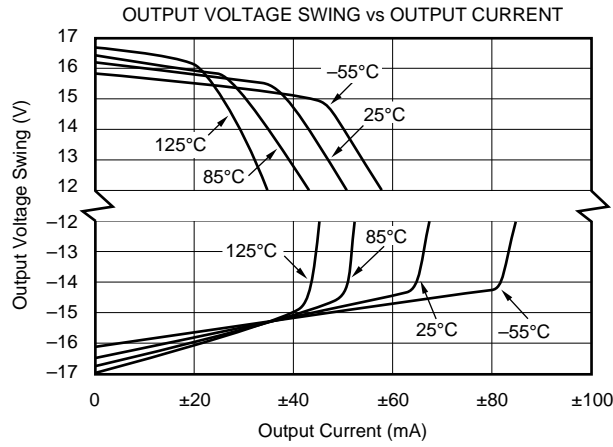

APPLICATIONS INFORMATION

Figure 1 shows the basic connections required for operation of the INA134. Decoupling capacitors are strongly recommended in applications with noisy or high impedance power supplies. The capacitors should be placed close to the device pins as shown in Figure 1. All circuitry is completely independent in the dual version assuring lowest crosstalk and normal behavior when one amplifier is overdriven or short-circuited.

As shown in Figure 1, the differential input signal is connected to pins 2 and 3. The source impedances connected to the inputs must be nearly equal to assure good common-mode rejection. A 10Ω mismatch in source impedance will degrade the common-mode rejection of a typical device to approximately 74dB. If the source has a known impedance mismatch, an additional resistor in series with the opposite input can be used to preserve good common-mode rejection.

Do not interchange pins 1 and 3 or pins 2 and 5, even though nominal resistor values are equal. These resistors are laser trimmed for precise resistor ratios to achieve accurate gain and highest CMR. Interchanging these pins would not provide specified performance.

AUDIO PERFORMANCE

The INA134 and INA2134 were designed for enhanced ac performance. Very low distortion, low noise, and wide bandwidth provide superior performance in high quality audio applications. Laser-trimmed matched resistors provide optimum common-mode rejection (typically 90dB), especially when compared to circuits implemented with an op amp and discrete precision resistors. In addition, high slew rate (14V/μs) and fast settling time (3μs to 0.01%) ensure good dynamic performance.

The INA134 and INA2134 have excellent distortion characteristics. THD+Noise is below 0.002% throughout the audio frequency range. Up to approximately 10kHz distortion is below the measurement limit of commonly used test equipment. Furthermore, distortion remains relatively flat over its wide output voltage swing range (approximately 1.7V from either supply).

OFFSET VOLTAGE TRIM

The INA134 and INA2134 are laser trimmed for low offset voltage and drift. Most applications require no external offset adjustment. Figure 2 shows an optional circuit for trimming the output offset voltage. The output is referred to the output reference terminal (pin 1), which is normally grounded. A voltage applied to the Ref terminal will be summed with the output signal. This can be used to null offset voltage as shown in Figure 2. The source impedance of a signal applied to the Ref terminal should be less than 10Ω to maintain good common-mode rejection.

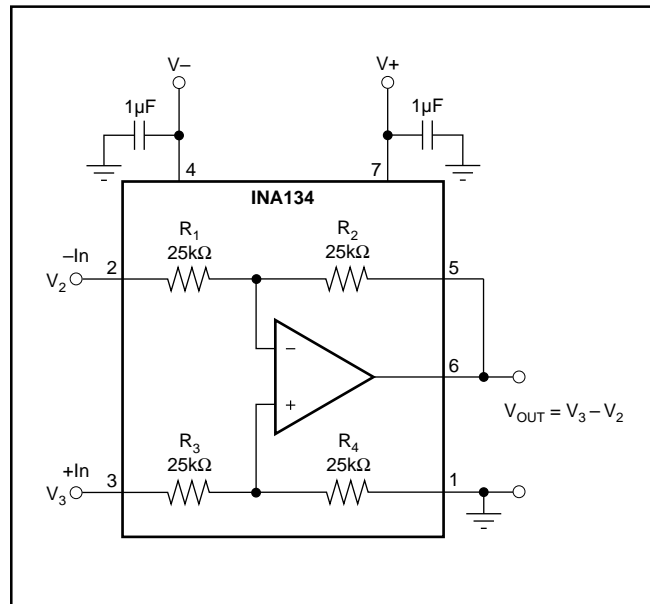

FIGURE 1. Precision Difference Amplifier (Basic Power Supply and Signal Connections).

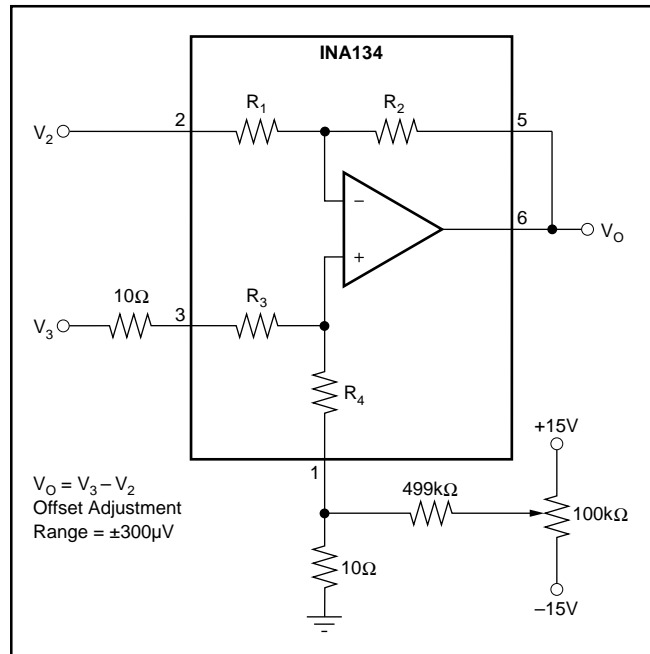

FIGURE 2. Offset Adjustment.

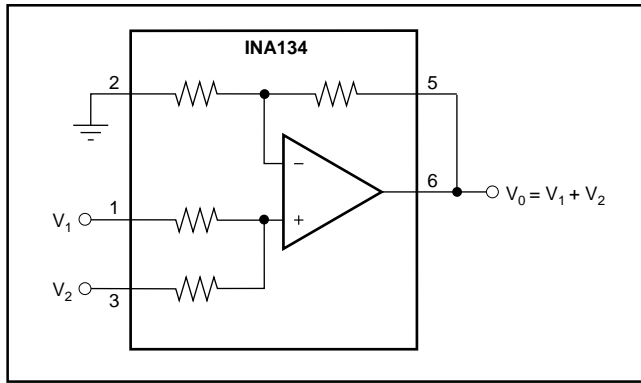

FIGURE 3. Precision Summing Amplifier.

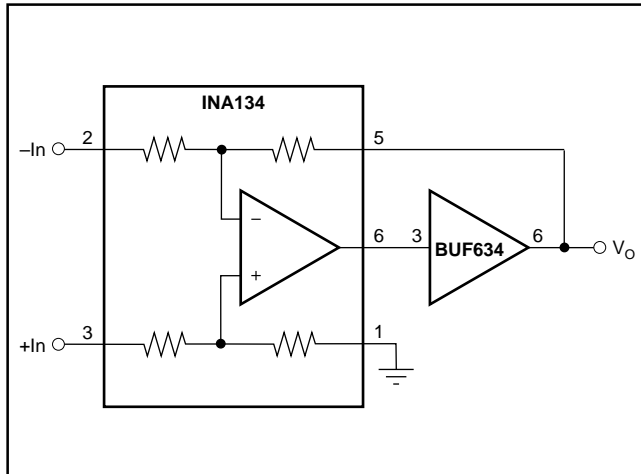

FIGURE 4. Boosting Output Current.

The difference amplifier is a highly versatile building block that is useful in a wide variety of applications. See the INA105 data sheet for additional applications ideas, including:

- Current Receiver with Compliance to Rails
- Precision Unity-Gain Inverting Amplifier
- $\pm 10V$ Precision Voltage Reference
- $\pm 5V$ Precision Voltage Reference
- Precision Unity-Gain Buffer
- Precision Average Value Amplifier
- Precision $G = 2$ Amplifier
- Precision Summing Amplifier
- Precision $G = 1/2$ Amplifier
- Precision Bipolar Offsetting
- Precision Summing Amplifier with Gain
- Instrumentation Amplifier Guard Drive Generator

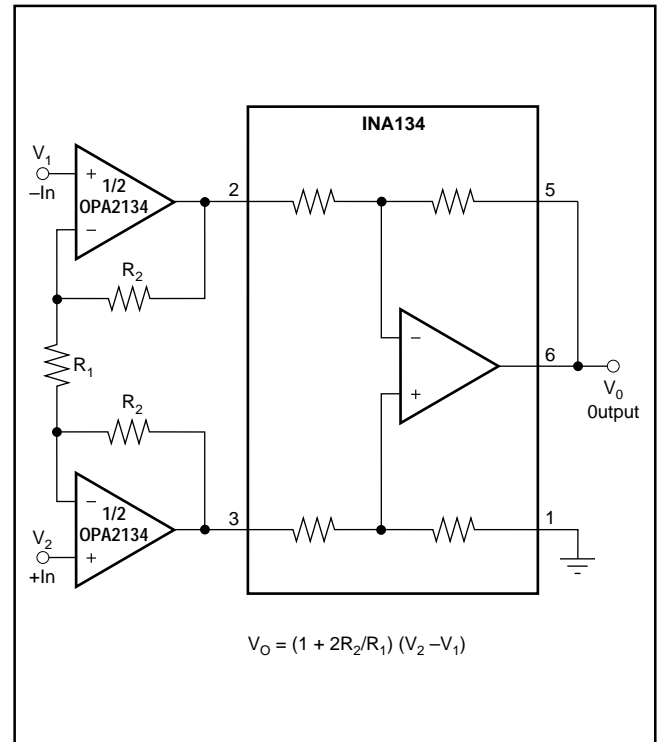

FIGURE 5. High Input Impedance Instrumentation Amplifier.

- Precision Summing Instrumentation Amplifier
- Precision Absolute Value Buffer
- Precision Voltage-to-Current Converter with Differential Inputs
- Differential Input Voltage-to-Current Converter for Low I_{OUT}
- Isolating Current Source
- Differential Output Difference Amplifier
- Isolating Current Source with Buffering Amplifier for Greater Accuracy
- Window Comparator with Window Span and Window Center Inputs
- Precision Voltage-Controlled Current Source with Buffered Differential Inputs and Gain
- Digitally Controlled Gain of ± 1 Amplifier

PACKAGING INFORMATION

Orderable Device	Status (1)	Package Type	Package Drawing	Pins	Package Qty	Eco Plan (2)	Lead/Ball Finish (6)	MSL Peak Temp (3)	Op Temp (°C)	Device Marking (4/5)	Samples
INA134PA	ACTIVE	PDIP	P	8	50	Green (RoHS & no Sb/Br)	CU NIPDAU	N / A for Pkg Type		INA134PA	Samples
INA134UA	ACTIVE	SOIC	D	8	75	Green (RoHS & no Sb/Br)	CU NIPDAU	Level-3-260C-168 HR	-40 to 85	INA134UA	Samples
INA134UA/2K5	ACTIVE	SOIC	D	8	2500	Green (RoHS & no Sb/Br)	CU NIPDAU	Level-3-260C-168 HR	-40 to 85	INA134UA	Samples
INA134UA/2K5E4	ACTIVE	SOIC	D	8	2500	Green (RoHS & no Sb/Br)	CU NIPDAU	Level-3-260C-168 HR	-40 to 85	INA134UA	Samples
INA134UAE4	ACTIVE	SOIC	D	8	75	Green (RoHS & no Sb/Br)	CU NIPDAU	Level-3-260C-168 HR	-40 to 85	INA134UA	Samples
INA2134PA	ACTIVE	PDIP	N	14	25	Green (RoHS & no Sb/Br)	CU NIPDAU	N / A for Pkg Type		INA2134PA	Samples
INA2134UA	ACTIVE	SOIC	D	14	50	Green (RoHS & no Sb/Br)	CU NIPDAU	Level-3-260C-168 HR	-40 to 85	INA2134UA	Samples
INA2134UA/2K5	ACTIVE	SOIC	D	14	2500	Green (RoHS & no Sb/Br)	CU NIPDAU	Level-3-260C-168 HR	-40 to 85	INA2134UA	Samples
INA2134UA/2K5E4	ACTIVE	SOIC	D	14	2500	Green (RoHS & no Sb/Br)	CU NIPDAU	Level-3-260C-168 HR	-40 to 85	INA2134UA	Samples
INA2134UA/2K5G4	ACTIVE	SOIC	D	14	2500	Green (RoHS & no Sb/Br)	CU NIPDAU	Level-3-260C-168 HR	-40 to 85	INA2134UA	Samples
INA2134UAE4	ACTIVE	SOIC	D	14	50	Green (RoHS & no Sb/Br)	CU NIPDAU	Level-3-260C-168 HR	-40 to 85	INA2134UA	Samples

(1) The marketing status values are defined as follows:

ACTIVE: Product device recommended for new designs.

LIFEBUY: TI has announced that the device will be discontinued, and a lifetime-buy period is in effect.

NRND: Not recommended for new designs. Device is in production to support existing customers, but TI does not recommend using this part in a new design.

PREVIEW: Device has been announced but is not in production. Samples may or may not be available.

OBSOLETE: TI has discontinued the production of the device.

(2) **RoHS:** TI defines "RoHS" to mean semiconductor products that are compliant with the current EU RoHS requirements for all 10 RoHS substances, including the requirement that RoHS substance do not exceed 0.1% by weight in homogeneous materials. Where designed to be soldered at high temperatures, "RoHS" products are suitable for use in specified lead-free processes. TI may reference these types of products as "Pb-Free".

RoHS Exempt: TI defines "RoHS Exempt" to mean products that contain lead but are compliant with EU RoHS pursuant to a specific EU RoHS exemption.

Green: TI defines "Green" to mean the content of Chlorine (Cl) and Bromine (Br) based flame retardants meet JS709B low halogen requirements of <=1000ppm threshold. Antimony trioxide based flame retardants must also meet the <=1000ppm threshold requirement.

- (3) MSL, Peak Temp. - The Moisture Sensitivity Level rating according to the JEDEC industry standard classifications, and peak solder temperature.
- (4) There may be additional marking, which relates to the logo, the lot trace code information, or the environmental category on the device.
- (5) Multiple Device Markings will be inside parentheses. Only one Device Marking contained in parentheses and separated by a "~" will appear on a device. If a line is indented then it is a continuation of the previous line and the two combined represent the entire Device Marking for that device.
- (6) Lead/Ball Finish - Orderable Devices may have multiple material finish options. Finish options are separated by a vertical ruled line. Lead/Ball Finish values may wrap to two lines if the finish value exceeds the maximum column width.

Important Information and Disclaimer:The information provided on this page represents TI's knowledge and belief as of the date that it is provided. TI bases its knowledge and belief on information provided by third parties, and makes no representation or warranty as to the accuracy of such information. Efforts are underway to better integrate information from third parties. TI has taken and continues to take reasonable steps to provide representative and accurate information but may not have conducted destructive testing or chemical analysis on incoming materials and chemicals. TI and TI suppliers consider certain information to be proprietary, and thus CAS numbers and other limited information may not be available for release.

In no event shall TI's liability arising out of such information exceed the total purchase price of the TI part(s) at issue in this document sold by TI to Customer on an annual basis.

OTHER QUALIFIED VERSIONS OF INA2134 :

- Enhanced Product: [INA2134-EP](#)

NOTE: Qualified Version Definitions:

- Enhanced Product - Supports Defense, Aerospace and Medical Applications

TAPE AND REEL INFORMATION

QUADRANT ASSIGNMENTS FOR PIN 1 ORIENTATION IN TAPE

*All dimensions are nominal

Device	Package Type	Package Drawing	Pins	SPQ	Reel Diameter (mm)	Reel Width W1 (mm)	A0 (mm)	B0 (mm)	K0 (mm)	P1 (mm)	W (mm)	Pin1 Quadrant
INA134UA/2K5	SOIC	D	8	2500	330.0	12.4	6.4	5.2	2.1	8.0	12.0	Q1
INA2134UA/2K5	SOIC	D	14	2500	330.0	16.4	6.5	9.0	2.1	8.0	16.0	Q1

TAPE AND REEL BOX DIMENSIONS

*All dimensions are nominal



Device	Package Type	Package Drawing	Pins	SPQ	Length (mm)	Width (mm)	Height (mm)
INA134UA/2K5	SOIC	D	8	2500	367.0	367.0	35.0
INA2134UA/2K5	SOIC	D	14	2500	367.0	367.0	38.0

D (R-PDSO-G14)

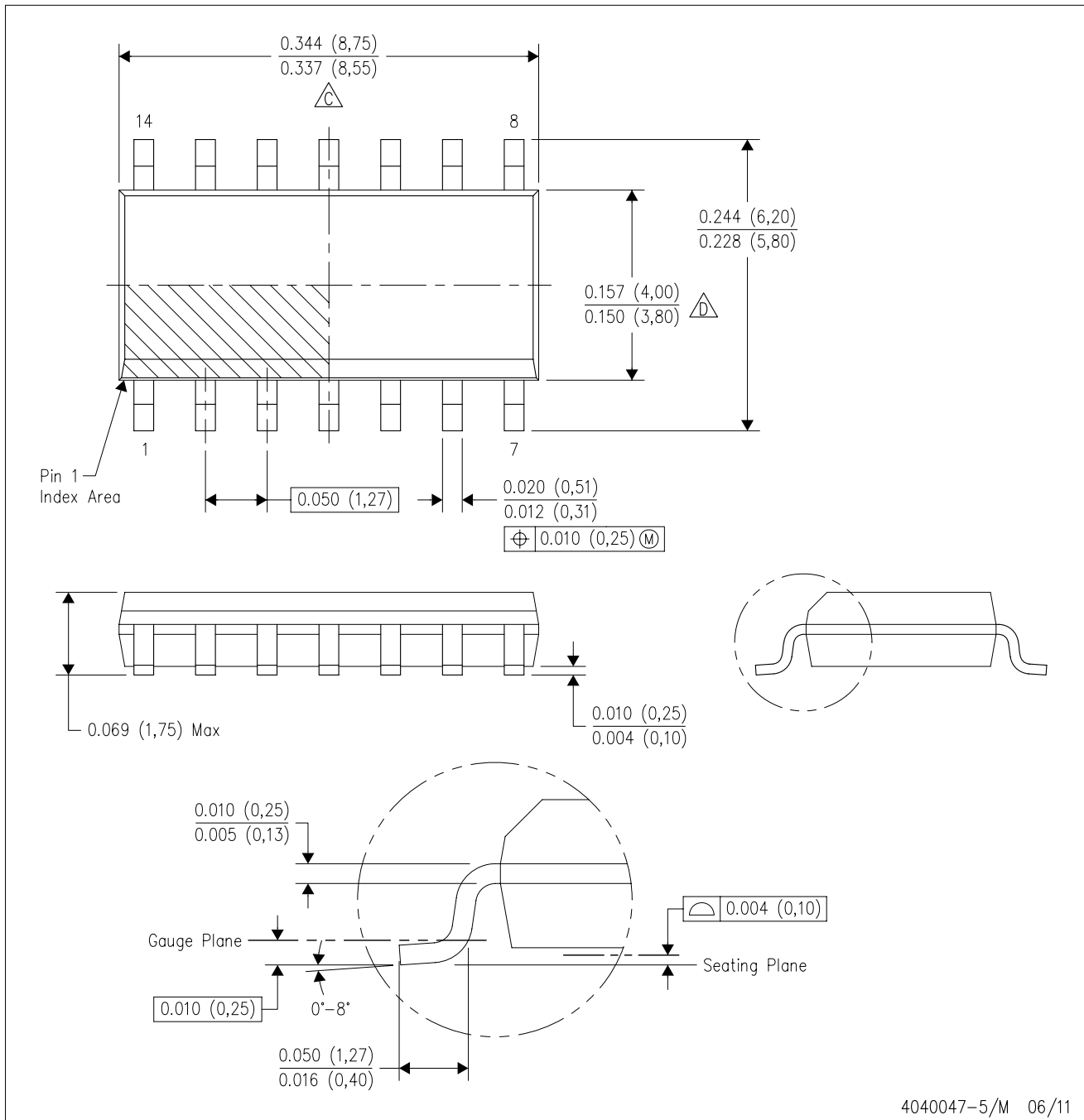
PLASTIC SMALL OUTLINE



4040047-5/M 06/11

- NOTES:
- A. All linear dimensions are in inches (millimeters).
 - B. This drawing is subject to change without notice.
 -  Body length does not include mold flash, protrusions, or gate burrs. Mold flash, protrusions, or gate burrs shall not exceed 0.006 (0,15) each side.
 -  Body width does not include interlead flash. Interlead flash shall not exceed 0.017 (0,43) each side.
 - E. Reference JEDEC MS-012 variation AB.

D (R-PDSO-G14)

PLASTIC SMALL OUTLINE



- NOTES:
- A. All linear dimensions are in millimeters.
 - B. This drawing is subject to change without notice.
 - C. Publication IPC-7351 is recommended for alternate designs.
 - D. Laser cutting apertures with trapezoidal walls and also rounding corners will offer better paste release. Customers should contact their board assembly site for stencil design recommendations. Refer to IPC-7525 for other stencil recommendations.
 - E. Customers should contact their board fabrication site for solder mask tolerances between and around signal pads.



D0008A

PACKAGE OUTLINE

SOIC - 1.75 mm max height

SMALL OUTLINE INTEGRATED CIRCUIT



4214825/C 02/2019

NOTES:

1. Linear dimensions are in inches [millimeters]. Dimensions in parenthesis are for reference only. Controlling dimensions are in inches. Dimensioning and tolerancing per ASME Y14.5M.
2. This drawing is subject to change without notice.
3. This dimension does not include mold flash, protrusions, or gate burrs. Mold flash, protrusions, or gate burrs shall not exceed $.006$ [0.15] per side.
4. This dimension does not include interlead flash.
5. Reference JEDEC registration MS-012, variation AA.

EXAMPLE BOARD LAYOUT

D0008A

SOIC - 1.75 mm max height

SMALL OUTLINE INTEGRATED CIRCUIT



LAND PATTERN EXAMPLE
 EXPOSED METAL SHOWN
 SCALE:8X



SOLDER MASK DETAILS

4214825/C 02/2019

NOTES: (continued)

- 6. Publication IPC-7351 may have alternate designs.
- 7. Solder mask tolerances between and around signal pads can vary based on board fabrication site.

EXAMPLE STENCIL DESIGN

D0008A

SOIC - 1.75 mm max height

SMALL OUTLINE INTEGRATED CIRCUIT



SOLDER PASTE EXAMPLE
BASED ON .005 INCH [0.125 MM] THICK STENCIL
SCALE:8X

4214825/C 02/2019

NOTES: (continued)

8. Laser cutting apertures with trapezoidal walls and rounded corners may offer better paste release. IPC-7525 may have alternate design recommendations.
9. Board assembly site may have different recommendations for stencil design.

P (R-PDIP-T8)

PLASTIC DUAL-IN-LINE PACKAGE



- NOTES:
- A. All linear dimensions are in inches (millimeters).
 - B. This drawing is subject to change without notice.
 - C. Falls within JEDEC MS-001 variation BA.

N (R-PDIP-T**)

PLASTIC DUAL-IN-LINE PACKAGE

16 PINS SHOWN



- NOTES:
- A. All linear dimensions are in inches (millimeters).
 - B. This drawing is subject to change without notice.
 - C Falls within JEDEC MS-001, except 18 and 20 pin minimum body length (Dim A).
 - D The 20 pin end lead shoulder width is a vendor option, either half or full width.

4040049/E 12/2002

IMPORTANT NOTICE AND DISCLAIMER

TI PROVIDES TECHNICAL AND RELIABILITY DATA (INCLUDING DATASHEETS), DESIGN RESOURCES (INCLUDING REFERENCE DESIGNS), APPLICATION OR OTHER DESIGN ADVICE, WEB TOOLS, SAFETY INFORMATION, AND OTHER RESOURCES "AS IS" AND WITH ALL FAULTS, AND DISCLAIMS ALL WARRANTIES, EXPRESS AND IMPLIED, INCLUDING WITHOUT LIMITATION ANY IMPLIED WARRANTIES OF MERCHANTABILITY, FITNESS FOR A PARTICULAR PURPOSE OR NON-INFRINGEMENT OF THIRD PARTY INTELLECTUAL PROPERTY RIGHTS.

These resources are intended for skilled developers designing with TI products. You are solely responsible for (1) selecting the appropriate TI products for your application, (2) designing, validating and testing your application, and (3) ensuring your application meets applicable standards, and any other safety, security, or other requirements. These resources are subject to change without notice. TI grants you permission to use these resources only for development of an application that uses the TI products described in the resource. Other reproduction and display of these resources is prohibited. No license is granted to any other TI intellectual property right or to any third party intellectual property right. TI disclaims responsibility for, and you will fully indemnify TI and its representatives against, any claims, damages, costs, losses, and liabilities arising out of your use of these resources.

TI's products are provided subject to TI's Terms of Sale (www.ti.com/legal/termsofsale.html) or other applicable terms available either on ti.com or provided in conjunction with such TI products. TI's provision of these resources does not expand or otherwise alter TI's applicable warranties or warranty disclaimers for TI products.

Mailing Address: Texas Instruments, Post Office Box 655303, Dallas, Texas 75265
Copyright © 2019, Texas Instruments Incorporated

Looking for pricing, stock, or lifecycle information?

Click below to explore more details on WIN SOURCE:

 [View INA2134PA](#) on WIN SOURCE

 [Texas Instruments](#) Information

Optimize Your Supply Chain with WIN SOURCE Solutions

-  Global Sourcing Solution
-  Obsolete Management
-  Cost Control Management
-  Shortage Management
-  Alternative Solution
-  Excess Inventory Management